

ASSEMBLY INSTRUCTIONS

# Elements 2 Person Workstation

Size: 1800mm

[www.jasonl.com.au](http://www.jasonl.com.au)

**Need help!**

Call us on  
**1300 527 665**

**jason.l**  
your office furniture mate

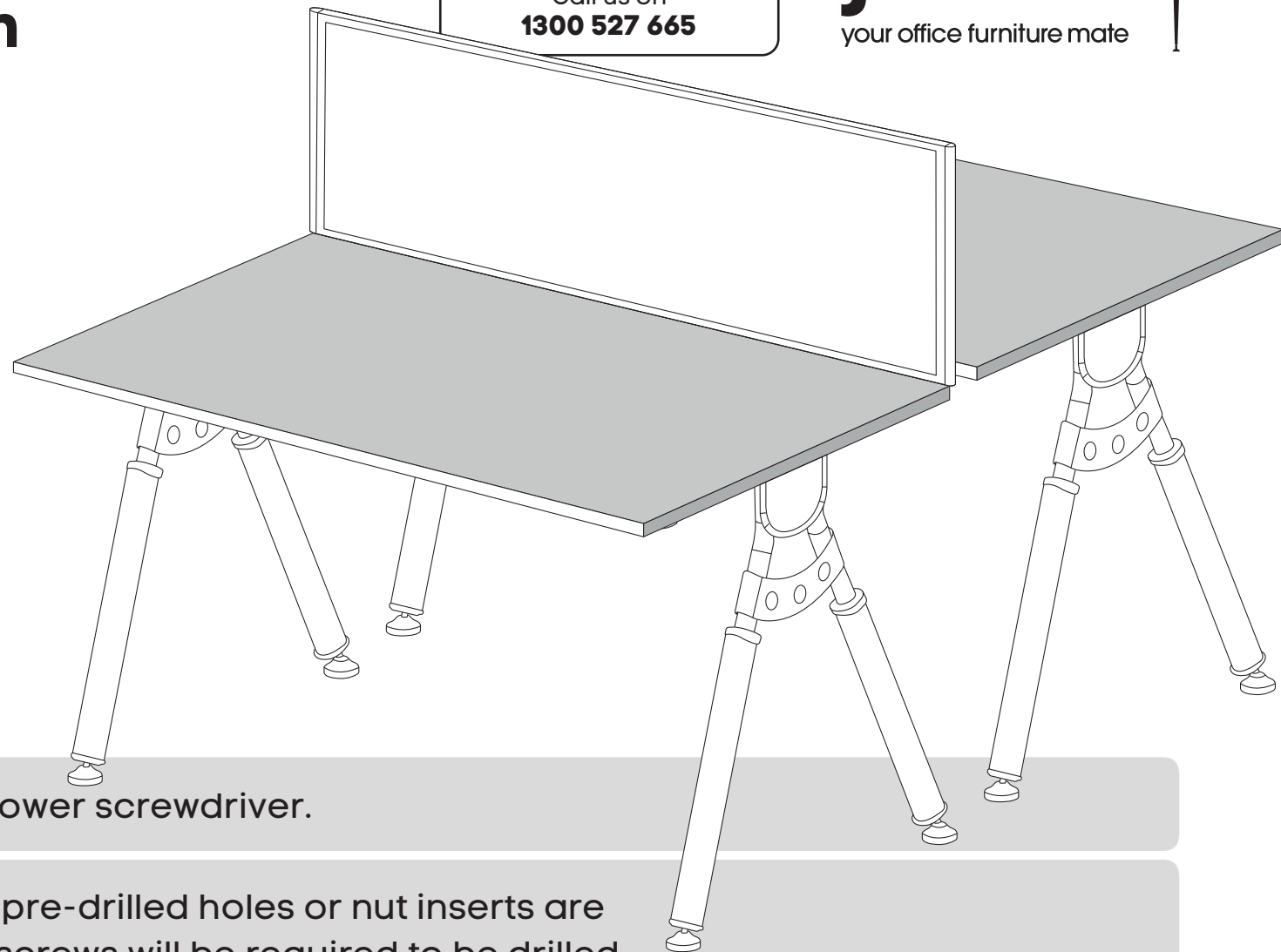

**Tools Required:** Power screwdriver.

**Special Note:** No pre-drilled holes or nut inserts are provided. Wood screws will be required to be drilled directly into underside of desk top.

 2 persons required for installation

## ASSEMBLY INSTRUCTIONS

# Elements 2 Person Workstation

Size: 1800mm

[www.jasonl.com.au](http://www.jasonl.com.au)

**Need help!**

Call us on  
**1300 527 665**

**jason.l**  
your office furniture mate

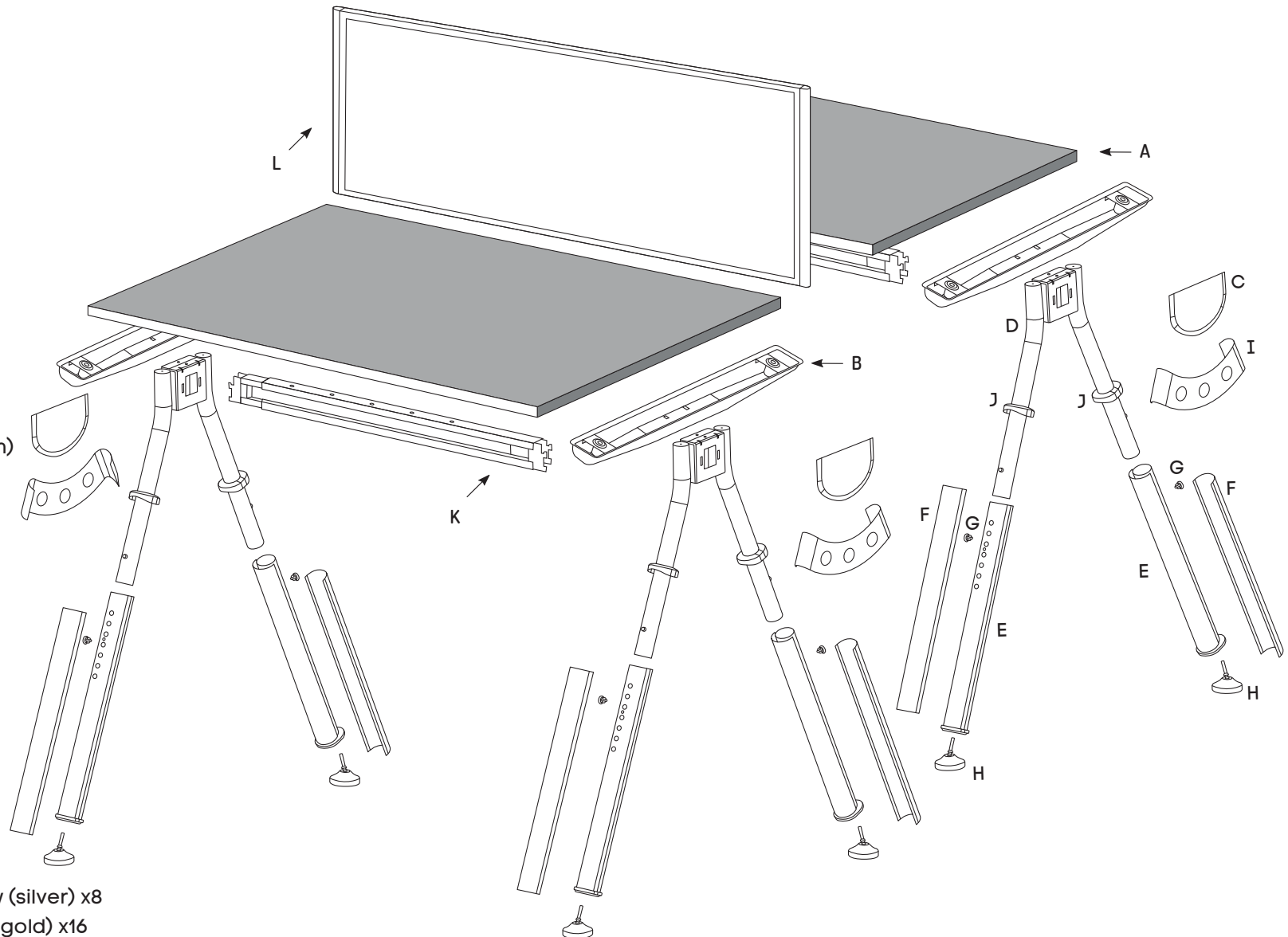

### COMPONENTS

- A Desk top x2 (1800mm x 800mm)
- B Top plate x4
- C Leg core insert x4
- D Leg core return x4
- E Leg sleeve x8
- F Sleeve cover x8
- G Fold Screen x8
- H Base Foot x8
- I Core cover x4
- J Sleeve Cap x8
- K Extendable Beam x2
- L Screen x1 (1800mm)
- M Rod Brackets for screens x2

### SCREWS

- N Phillip Head M6\*15 Wood Screw (silver) x8
- O Phillip Flat Head M6\*20 Screw (gold) x16
- P H6x30 x8

## ASSEMBLY INSTRUCTIONS

# Elements 2 Person Workstation

Size: 1800mm

[www.jasonl.com.au](http://www.jasonl.com.au)

**Need help!**

Call us on  
**1300 527 665**

**jason.l**  
your office furniture mate



01

- Unwrap all leg components.
- Remove sleeve cap (J) and sleeve cover (F) from all leg sleeves.
- Insert base foot (H) into leg sleeve (E) by rotating base foot (H) clockwise.
- Insert sleeve cap (J) onto leg core (D) for all legs.
- Insert leg sleeve (E) onto leg core (D) for all legs. TIP: Keep height adjustment holes pointing outwards.
- Place leg core insert (C) onto leg core (D) for all legs.
- Place core cover (I) onto leg core (D) for all legs.
- Place sleeve cover (F) over leg sleeve (E) for all legs.

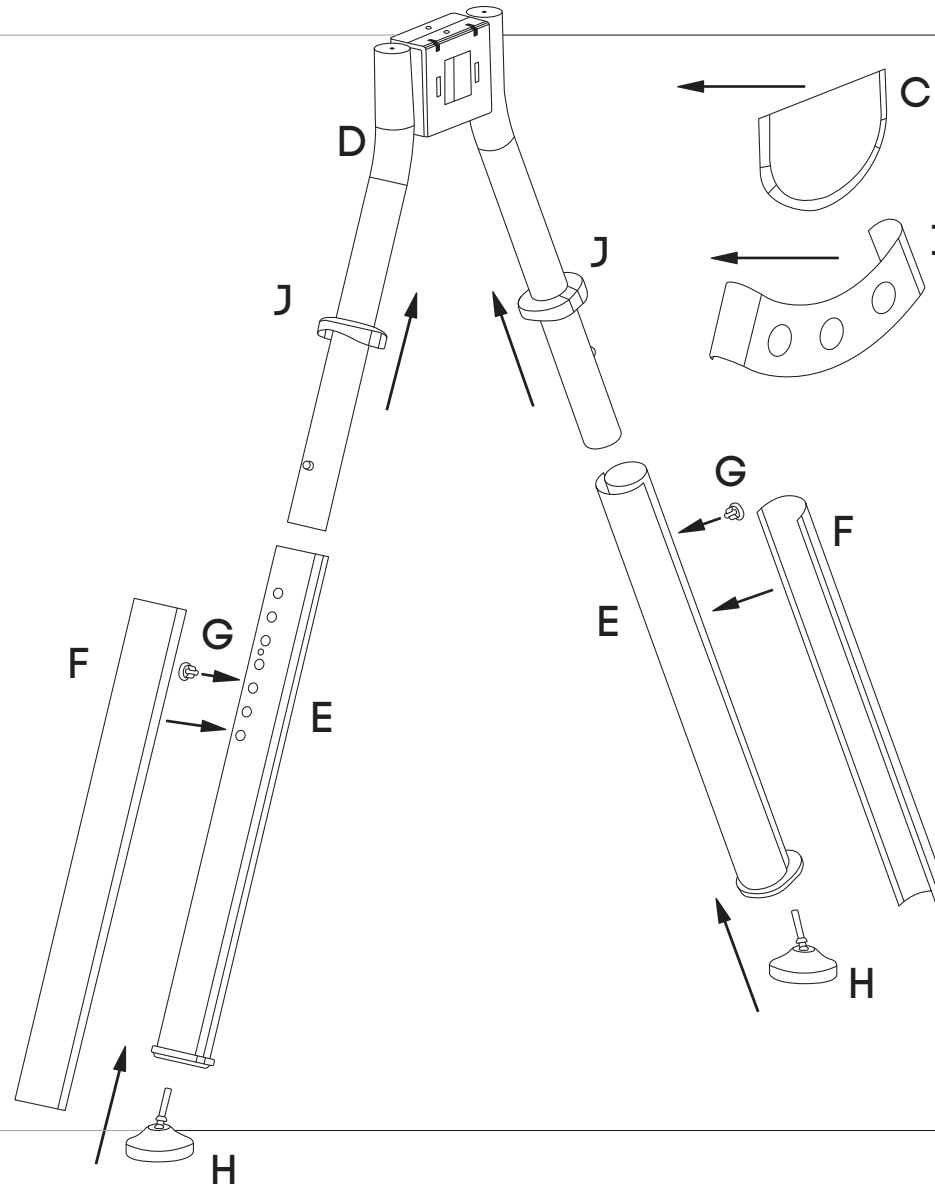

ASSEMBLY INSTRUCTIONS

# Elements 2 Person Workstation

Size: 1800mm

[www.jasonl.com.au](http://www.jasonl.com.au)

Need help!

Call us on  
1300 527 665

**jason.l**  
your office furniture mate

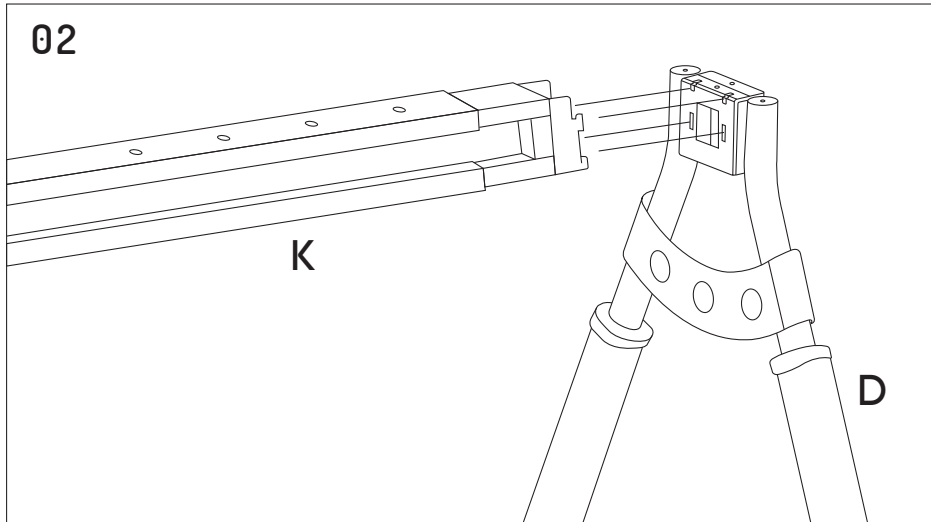

Connect extendable Beams (K) to Legs Core (D)

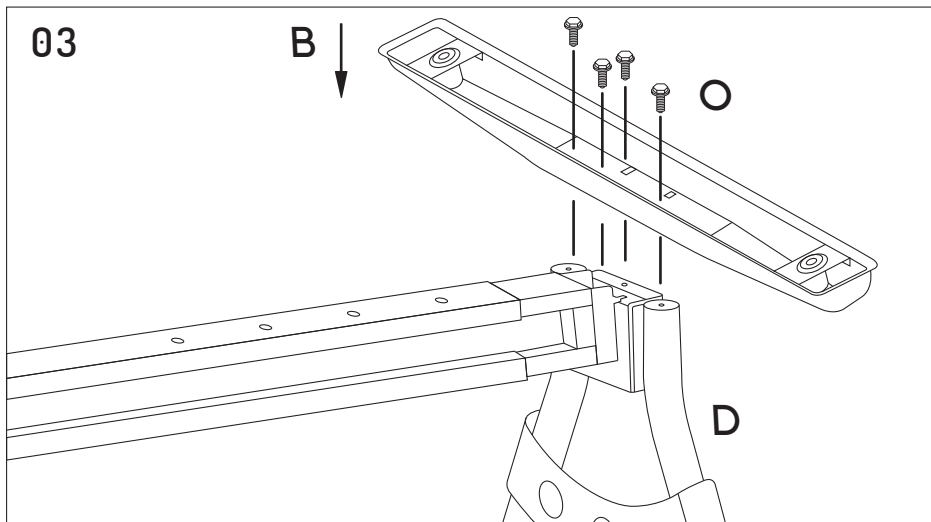

Tighten Top Plates (B) to legs core (D) by tightening Screw (O).

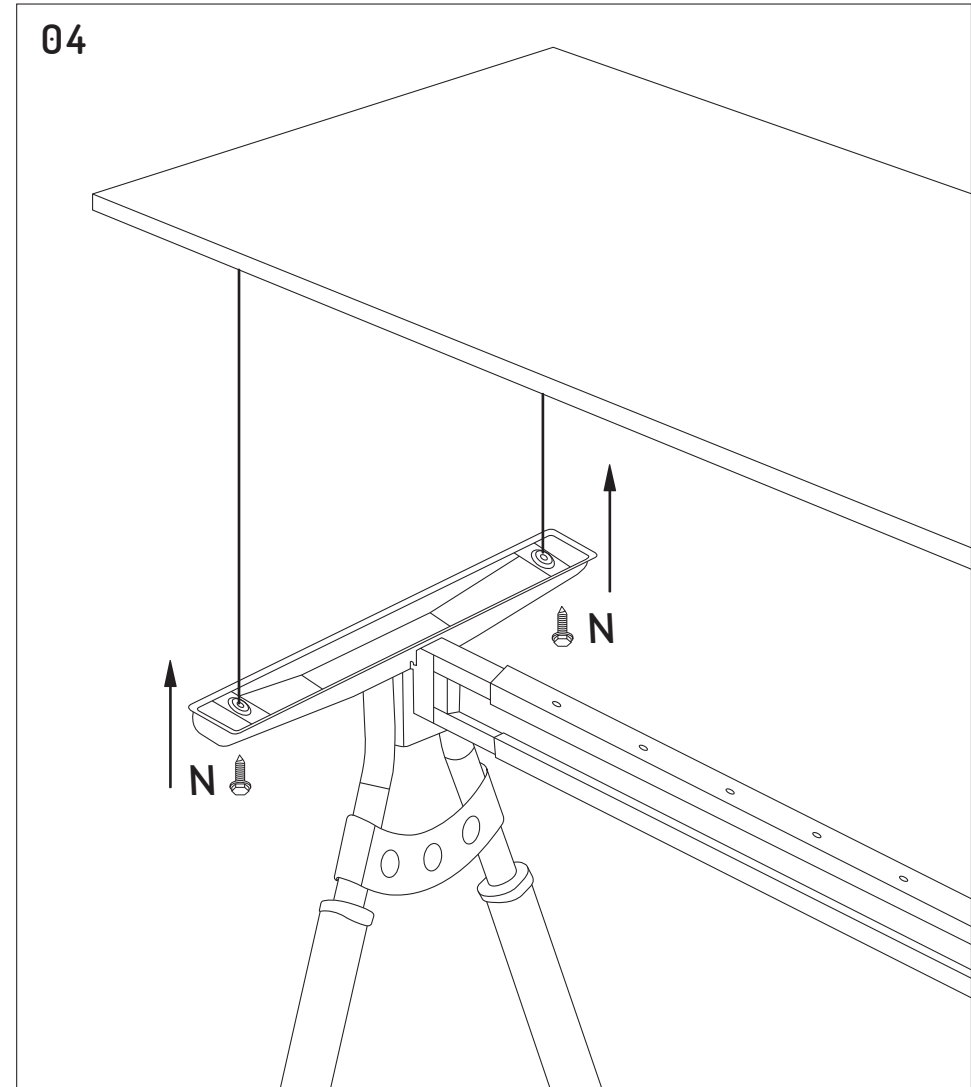

Attach legs + beams to Desk Tops by tightening Screws (N).

ASSEMBLY INSTRUCTIONS

# Elements 2 Person Workstation

Size: 1800mm

[www.jasonl.com.au](http://www.jasonl.com.au)

**Need help!**

Call us on  
**1300 527 665**

**jason.l**  
your office furniture mate

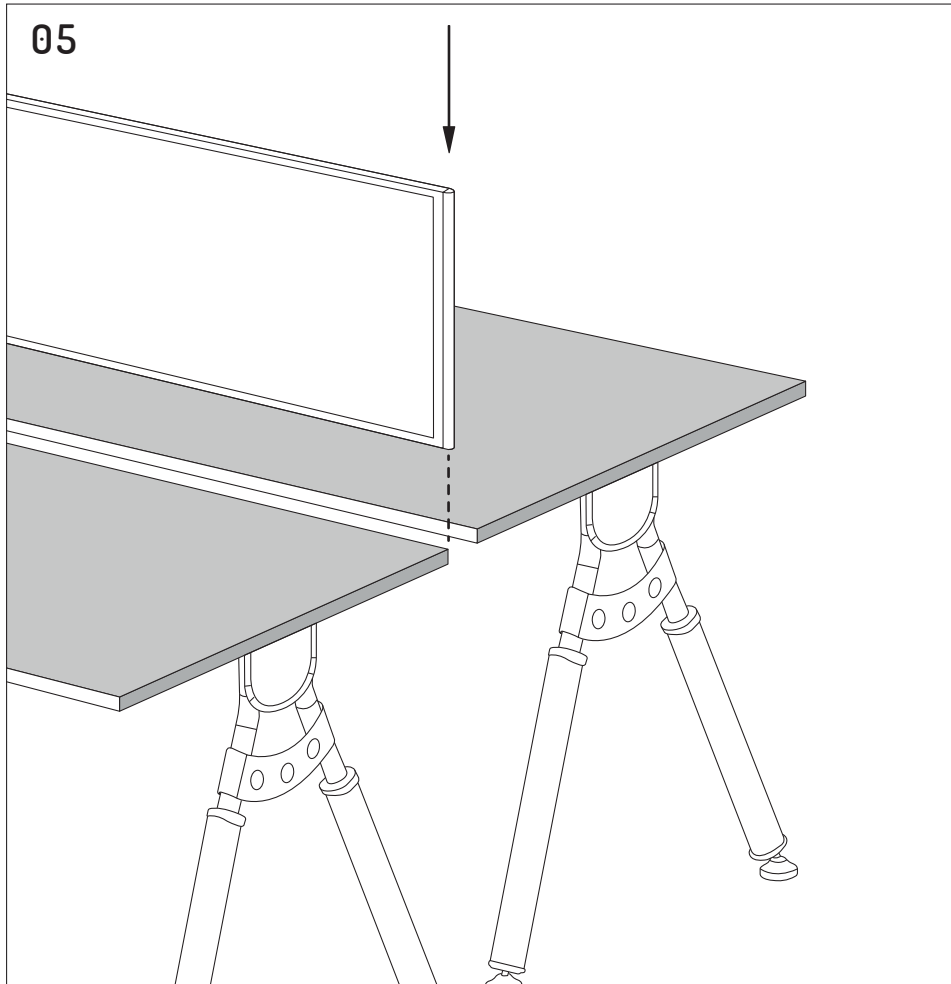

Place screen (L) in the gap, aligned with desk tops (A).

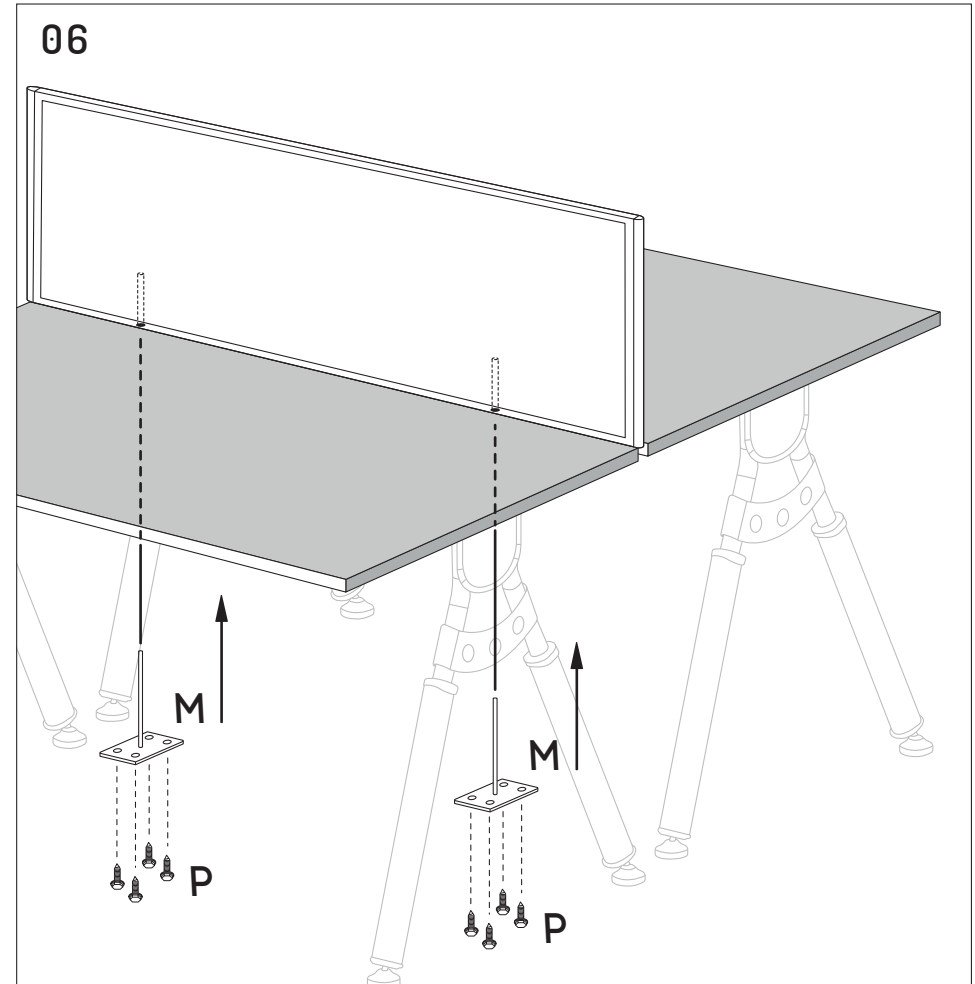

Place 10mm Rod Brackets (M) into designated screen holes.  
Drill desk tops (A) with H6x30 screws (P) to assemble the screens.