



AN INSTROTEK® COMPANY

CPN MC3 ELITE™

Moisture/Density Gauge



OPERATING MANUAL

www.InstroTek.com

'This page may be removed from the manual to prevent the unauthorized access to the restricted menu functions of the InstroTek/CPN MC-3 Elite.'

Restricted Menu Function

Access Code:

3548

Please note up to 2% of the mechanical components used in the gauge may be recycled material.

This page may be removed from the manual to prevent the unauthorized access to the restricted menu functions of the InstroTek/CPN MC-3 Elite.

© 2018 InstroTek, Inc.
MC-3 Elite Moisture/Density Nuclear Gauge
Operation Manual Version 4

1. Table of Contents

1. INTRODUCTION AND GAUGE COMPONENTS	2
2. GETTING STARTED	4
3. MENU FUNCTIONS	25
4. RADIATION THEORY	47
5. RADIATION SAFETY AND HEALTH PHYSICS	53
6. TRANSPORTATION	65
7. GAUGE THEORY	77
8. ROUTINE MAINTENANCE AND TROUBLESHOOTING	85
9. SPECIFICATIONS AND APPENDICES	92
10. INDEX	101
11. WARRANTY	110

1. Introduction

Thank you for your purchase of the InstroTek/CPN Model MC-3 Elite. InstroTek/CPN has been a world leader in the development and implementation of nuclear gauges for over 45 years. InstroTek/CPN design and manufacture gauges used in variety of applications such as agriculture and irrigation control, coal density and moisture determination, moisture in pipe insulation and many more.

The Elite gauge was designed to meet the demands of the construction market with reliability, accuracy and reduced costs. It is designed to reduce the daily field effect of moisture and dust, providing enhanced reliability and accuracy in all rugged construction environments.

The software features are easy to follow. The four line display provides large characters and intuitive instructions to help the operators navigate through the different functions. The diagnostics features allow the operators diagnose problems on the field, increasing the gauge testing productivity.

Our technical staff includes some the most experienced nuclear moisture/density gauge developers and engineers in the world. We believe you will be impressed with the MC-3 Elite and its functionality.

We will provide you with a superior gauge, unmatched expertise, and exceptional service.

Model MC-3 Elite and Standard Accessories



Fig 1.1 MC-3 Elite Nuclear Gauge & Accessories

Model MC-3 Elite

- 1. MC-3 Elite**
- 2. Reference standard block**
- 3. Scraper plate**
- 4. Extraction tool**
- 5. Drill rod**
- 6. Type A shipping case**
- 7. AC and DC charger, one each**
- 8. Manual of operation and gauge paperwork**
- 9. Gauge and Case Lock, one each**

2. Getting Started

Before using this gauge, it is recommended that the user read this manual and understand the operation of the gauge.

Operating your Model MC-3 Elite

This chapter covers the basic operation of your gauge from powering on to taking a measurement. This manual should also be used for Smart-MC electronic upgrade to older MC1 DRP and MC3 gauges.

Important: In order to use this gauge, the operator is required to meet and understand the provisions of the radioactive materials license under which he/she is authorized to operate this gauge.

Charging the Batteries

When the gauge is powered on, check for the low battery warning ("N" or "NA" displayed). If the low battery warning does not appear on the display, the gauge is ready for use and does not require additional charge.

The MC-3 Elite contains 6 welded AA NiMH batteries. The batteries are charged at the factory prior to calibration. Life of rechargeable batteries depends on the number of charge/discharge cycles. For best results, only charge your batteries, when the battery low warning is displayed. The gauge will display an "N" in the top right when the battery is getting low. The gauge will display "NA" when the NiMH batteries have been drained and the gauge has switched to the alkaline backup.

The provided DC charger can be used for emergency charging in the field. Plug this charger into your vehicle charger outlet and charge the gauge for 30 minutes. This should provide enough battery power to your gauge to complete your testing

for the day. Charge the gauge overnight after the day of operation.

During a charging session a “C” will appear in the upper right hand corner of the display. The gauge is designed with a SmartCharge chip that prevents the battery from over charging.

The gauge cannot be turned off while the unit is being charged.

Powering the Gauge On

Use the ON/YES key to power the gauge on. When the gauge is powered on the CPN Elite will go through the following Self-Test screens:

CPN Elite
Version: #. ##

Self-Test will take approximately 15 seconds and checks for proper operation of the keypad, density and moisture detectors, and the High Voltage. Place the gauge on the standard block during self-test.

High Voltage Test

Calibration
Reminder

The Gauge will go to the Ready display after a successful Self-Test. If a failure is detected during Self-Test, one or all of the following messages will display on the screen.

1. **Keypad Test Failed** - This indicates a faulty keypad or a stuck key. Pressing any key on the keypad during this test will display this error. If a key is pressed by mistake during this test, simply restart the gauge by powering off and then on again. However, if the error is displayed again, contact your InstroTek representative.
2. **He-3 Tube Failure** - If the gauge is on the reference standard block during self-test, then there is a potential problem with the electronics or the He-3 tube. If the gauge is not on the reference standard block, place it on the reference standard block and repeat this test. Contact your InstroTek representative if this error is repeated;
3. **GM tube failure** - This indicates if one or both GM tubes are not operational. Contact your InstroTek representative.

4. **High Voltage Failure** - This indicates the high voltage module is not working properly.

Important: It is suggested to always power the gauge on and allow the self-test to complete before leaving for a job site. Place the gauge on the reference standard block and check the results of the Self-Test and ensure there are no failures. Charge the batteries if needed by the provided AC or DC charger (Refer to the section on Charging Batteries).

Note: To preserve battery life for extended gauge operations, the gauge will go into a shutdown mode if no key is pressed in one hour. Simply press the **ON** key when you are ready to start again. The gauge will not run the Self-Test if shut down was due to an automatic one hour 'inactive gauge shut down' feature.

Setting Units of Measurement

The default for the gauge is lb. /ft³ (PCF). You may change the units to kg/m³ or g/cc by completing the following steps.

Press the **MENU** button, the first screen will be:

1. Recall
 2. Set Depth
 Up/DOWN FOR Next
 Select#, ESC Exit

Scroll **DOWN** 5 screens

11. Auto Scroll
 12. Set Units
 Up/DOWN FOR Next
 Select#, ESC Exit

Press **12**, (button **1**, then **2**)

1. PCF
 2. kg/m³
 3. GCC
 Select#, ESC Exit

Use the number buttons to select 1 for PCF (pounds per cubic foot), 2 for kg/m³, or 3 for g/cc.

After selecting the Unit of Measurement, the Elite returns to the menu screen.

11. Auto Scroll
 12. Set Units
 Up/DOWN FOR Next
 Select3, ESC Exit

Press **ESC** to return to the gauge ready screen

```
GAUGE READY  
COUNT TIME: 1 min.  
Depth: BS OFFSET: N  
02/16/2013 12:07 PM
```

Setting Test Time

The gauge provides four different testing times: 15 seconds, 30 seconds, 1 minute, and 4 minutes. The gauge precision improves with increased test time. In general, a one minute count will result in a precision that is two times better than a 15 second count and a four minute count precision is twice as good as a one minute count. Refer to your local specifications for selection of an appropriate testing time.

Press the **TIME** button on the front panel.

```
Cnt Time: 15 sec.  
UP/DOWN TO CHANGE  
YES TO ACCEPT  
ESC to Exit
```

Scroll **UP** or **DOWN** to set a desired count time (15 seconds, 30 seconds, 1 minute, or 4 minute)

Press **YES** when you have chosen the time. You will be returned to the gauge ready screen.

```
GAUGE READY  
COUNT TIME: 1 min  
Depth: BS OFFSET: N  
02/16/2013 12:07 PM
```

Measurement Depth

The Elite gauge is designed and is equipped with an automatic non-contact magnetic depth indicator. The depth is automatically read as you lower the source into measure position and the appropriate constants are selected for calculation of density.

The gauge can be placed into manual depth mode by disabling the Automatic depth mode from the MENU functions

Taking a Daily Standard Count

It is important that a minimum of one daily standard count is taken at each job site. The moisture standard count should be within 2% and density standard count should be within 1% of the average of the previous four standard counts. If the average of the previous four standard counts is taken more than three months from the current standard count, take four new standard counts and generate a new average for comparison. Check the density standard count and ensure it is within the range of the expected standard count provided with the calibration paperwork.

The standard count is used to correct for decay in the radioactive source, especially for the Cs-137 density source. Keeping a log of the daily standard counts is a good indicator of gauge operation from day to day. Elite will store the last 30 standard counts in its memory. They can be recalled and reviewed from the MENU functions. To obtain the most representative standard count in the field, allow the gauge to stabilize to the field environment for a minimum of 15 minutes. Remember the following steps, when taking standard counts:

1. Find a level location close to the test site and setup your polyethylene reference standard block.

2. Place the gauge on top of the standard block on a level surface; the keypad end of the gauge should be pushed against the metal butt plate. See Fig 2.1.
3. Ensure the reference standard block is placed on a dense material, such as soil, asphalt, or concrete. Do not take standard counts on truck tailgates, tables, or non-solid floors.
4. When you place the source rod in the "SAFE" position notch, gently tap it down without pulling the trigger to make sure the handle plunger is properly seated inside the notch. Ensure the handle is reasonably parallel with the gauge.



Fig 2.1 Reference Standard Count Position

Press the **STD** button on the front panel. The Standard Count will display with your previous standard count.

DS= ###
MS= ###
Take New Std Count?
Press YES or NO

Press the **ON/YES** button to take a new count or press **OFF/NO** to cancel and go to the gauge ready display.

Place Gauge on Poly
Std. Block in SAFE
Position
Press Start

Press the **START/ENTER** button. In Auto Depth mode, if the source rod is not in the Safe position, the gauge will display a message indicating "Depth not at Safe Position"

The time will begin to count down from 240 seconds (4 minutes).

Standard Count
Time: 240 sec.

After 240 seconds the results of your standard count will be displayed

DS= ###
MS=###
Use New STD CNT?
Press YES or NO

DS is the density standard count and MS is the moisture standard count. Log these numbers into your Daily Standard Log Record (notebook), and then press the **ON/YES** button

The gauge ready screen will appear and you are now ready to begin testing.

Note: If there are no standard counts in the gauge, a message will display indicating "Invalid Std". Take a new standard count prior to testing.

Setting Target/Laboratory Density Values

The gauge is capable of calculating and displaying percent compaction based on user defined laboratory values. Pressing the MAX/PR button allows the laboratory value to be entered. Select PR (Proctor) for soil/aggregate materials and Max. Dens. (Marshall or laboratory max (rice) density) for percent compaction on asphalt materials. Soil Specific Gravity (SG) (which is used to calculate % Soil Air Voids) can also be entered. %MAX, %PR, and %Soil AV will be calculated and displayed automatically after each measurement.

Press the **MAX/PR** button.

1. Proctor
 2. Max. Dens
 3. Soil SG
- Select #. ESC Exit

Press **1** for setting soil target value **PR** (Proctor), and
Press **2** for setting asphalt target value **MAX** (Max. Dens.).
Press **3** for setting soil specific gravity (**SG**).

Proctor

PR: #### PCF
Change value?
Press YES or NO
ESC to Exit

Press the **ON/YES** button

Enter Value For
Proctor: ### PCF
ENTER to Accept
ESC to Exit

Once the PR value is entered, the gauge ready screen will display.

Max Dens.

MA: #### PCF
Change value?
Press YES or NO
ESC to Exit

Press the **ON/YES** button

Enter Value For
Max. Dens: ### PCF
ENTER to Accept
ESC to Exit

Once the MA value is entered, the gauge ready screen will display.

Soil SG

Soil SG: #### PCF
Change value?
Press YES or NO
ESC to Exit

Press the **ON/YES** button

Enter Value For
Soil SG: ### PCF
ENTER to Accept
ESC to Exit

Once the SG value is entered, the gauge ready screen will display.

Equations used by the gauge

$$\%MA = \%Compaction = \frac{WD}{MA} \times 100$$

Where: WD (Wet Density) is measured by the gauge.

$$\%PR = \frac{DD}{PR} \times 100$$

Where: DD (Dry Density) is calculated by the gauge. M (Moisture) content is in PCF.

$$DD = WD - M$$

% PR can also be used to determine % Solids, if the “void-less density” of the material can be determined.

$$\% \text{Soil Air Voids} = 100 * [1 - \left(\frac{DD}{SG} \right) - M]$$

Where: DD is the dry density in g/cm³, SG is the soil specific gravity provided by the user, and M is the moisture content in g/cm³.

Site Preparation (soil, aggregates, and granular materials)

1. Locate a test site away from other gauges and large objects that could influence the gauge results. These items include your truck, large concrete barriers or walls. If the test site is required to be near or close to walls, then refer to the special functions section, Offset and Trench Correction.
2. Using the edge of the scraper plate provided, level the test surface by removing raised areas and voids. If there are any small voids that weren't filled, use some surrounding local soil or material to bring them up to grade.
3. Place the extraction tool provided with the gauge over one of the guides on the scraper plate.
4. Place the drill rod provided with the gauge into the same guide as the extraction tool.
5. With a hammer of about 4-8 lbs., drive the drill rod into the surface of the grade.

Caution: Eye, hand and shin protections must be worn while forming a hole in the surface.

The drill rod has 6 notches spaced 2" apart, which are numbered for the depth of the reading. These numbers show the depth necessary to drive the rod for a particular gauge depth reading. The rod depth indicators automatically adds 2" extra depth to the hole, which is necessary for accurate readings.

6. Removal of the drill rod should be done in a manner that will not damage the hole. Using a twisting motion, pulling straight up on the drill rod might be the best way to extract the rod from the material. Care must be taken to preserve the integrity of the hole. Collapsed or larger than required holes can negatively influence your readings.

Site Preparation (Asphalt)

1. Locate a test site away from other gauges and large objects that could influence the gauge results. These items would include work trucks, large concrete barriers or walls.
2. For coarse, open graded mixtures, fine fill material, such as Portland cement or fine sand, should be used to fill the voids, but taking care not to completely cover the surface of the asphalt. The gauge base should be resting on the asphalt not the filler.
3. After the gauge has been placed on the test site, rock the gauge back and forth by pressing on opposite corners. Minimizing the amount of rock will ensure the most accurate results achievable in the field.

Taking Measurements

Lower the source rod to the desired depth by pulling the handle trigger back and pushing down on the handle. In positions of measurement, always 'lock' in to the position by allowing the trigger to engage the notch and then gently pushing the handle down to 'seat' on the notch.

Caution: Never drive the source rod into the soil by hammering the gauge handle down.

To start measurement, press **START/ENTER**. The gauge will then begin taking counts.

Depth: BS
Time: 15 sec.

After the gauge has completed its count time, it will display:

If you exit out of the results information, you can use the Recall function under menu to retrieve your results.

M Count: ##
D Count: ##
MCR: ### DCR: ###
Press UP/DOWN

To make recording this information easier, you can set up the Auto Scroll Feature under Menu.

WD: #. # PCF
%MA: #. #
%Voids: #. #
Press UP/DOWN

Moist: #. # PCF
DD: #. # PCF
%Mois: #. # %PR: #. #
PRESS UP/DOWN

MM/DD/YYYY HH:MM AM
DEPTH: BS
Soil %AV: 10.0
PRESS UP/DOWN

Where:

M count = Moisture count

D Count = Density count

MCR = Moisture count ratio (M Count/MS)

DCR = Density count ratio (D Count/DS)

WD = Wet density

%MA = Percent Compaction $((WD/Max\ Dens.) \times 100)$

%Void = Percent air voids $(100-\%MA)$

Moisture = Moisture density in PCF, Kg/m³ or gcc depending on the unit selected

DD = Dry density (WD- Moisture)

% Mois. = Percent moisture $((Moisture/DD) \times 100)$

% PR = Percent Proctor $((DD/PR) \times 100)$

Project Storage and Printing

The Elite is equipped with data storage capability. Up to 10 Projects and 40 stations (readings) per project can be stored in the Elite. The stored data can be printed or transferred into a USB external drive located on the front panel.

To access this feature and start a new project press the **Project Print** button:

1. Auto Store
2. Start New Project
UP/DOWN for Next
Select #, ESC Exit

Select **2** to start a new project. Press each alphanumeric key repeatedly to select a desired letter. Advance to next letter by pressing another alphanumeric key. Use the **UP/DOWN** button to advance to the next position, if letter required is on the same key as the one you have just selected. Press **YES** to accept

Enter Project
Name:
YES to Accept
ESC to Exit

Choose **1** to auto store each station within the project. Press **2** to manually enter the station number.

Starting Station
Number: ##
YES to Accept
ESC to Exit

Choose the desired starting station number and press **YES**. When Auto Store station is enabled, the station numbers will increment up sequentially from the starting station number.

Enable Auto Store?
Press YES or NO

Choose **YES** to enable Auto Store to automatically store the project after each reading. Otherwise, to store the data manually, press the **STORE** key after each reading.

To use an existing Project or to print a Project, press the **PROJECT PRINT** key on the front panel and select option 3.

3. Sel. Stored Proj.
4. Print Data
UP/DOWN for Next
Select #, ESC Exit

Select **Project** from the list using the number choices. To print, press the **PROJECT PRINT** key and select option 4.

3. Sel. Stored Proj.
4. Print Data
UP/DOWN for Next
Select #, ESC Exit

Print Data
1. Print All Data
2. Print one Project
ESC to Exit

Select which data you would like to print and press the corresponding number button.

After you have selected the print option connect the printer to the gauge and press **ENTER**.

To store to a USB device press, press the **PROJECT PRINT** Key and scroll down to the third page, option 5

5. Send Data to USB
6. Review Data
UP/DOWN for Next
Select #, ESC Exit

Select which data you would like to save and press the corresponding number button.

Insert a USB drive and press **ENTER**.

To review or delete data for a particular project select the **PROJECT PRINT** button and scroll down to option **6** or **7**.

3. Menu Functions

This chapter contains functions that may not be used every day. Features under Menu functions are important and will be used periodically for testing under special circumstances and special materials, performing diagnostics test and calibration functions.

Pressing the **MENU** button on the front panel will access menu functions. Some of the menu functions require an access code; contact your RSO or your supervisor to obtain this code.

The following list of functions is available under MENU:

1. **Recall** – Recover/retrieve the most recent gauge test results.
2. **Offset** – This mode provides three different offset functions; Density, Moisture and Trench correction. Use this function to offset factory calibration readings or correct for influence of the trench wall in the field.
3. **Auto Scroll** – Helps users record data in the field. The test screens automatically scroll every 5 seconds.
4. **LCD Backlight** – Enable/Disable the LCD backlight for easy viewing of data and keypad during night work.
5. **Diagnostic Test** – Check the Battery Voltage, High Voltage, Temperature, Memory Reset, Depth Sensor, Key Pad Test, USB Store Test, Count Test, Shutdown Test, Light Test and Extended Counts.
6. **Drift Test** – Test for electronic drift.
7. **Stat Test** – Test the electronic stability of the gauge.
8. **Auto-Depth** – Enable/Disable the calibration of the Auto-Depth feature for calibration of the depth sensors.
9. **Review STD Counts** –View the last 30 Standard Counts and the corresponding date for each standard count.

10. **Select Language** – Select either English or Spanish for the language.
11. **Set Units** – Change units between lb./ft³, kg/m³, and g/cc.
12. **Standard Mode** – Enable/Disable Average Standard Mode, Decay Mode and Chi² Test Mode.
13. **Serial Number** – Enter the serial number of the gauge.
14. **Date/Time** – Set the current date and time.
15. **Buzzer ON/OFF** – Enable/Disable the buzzer/alarm function of the Elite.
16. **Special Calibration** – Adjust calibration constants for local and special materials.
17. **Nomograph Mode** – Enable/Disable mode so the gauge can be used on thin layer asphalt overlays.
18. **Calibration Constants** – Enter and store calibration constants used for determination of the material density and moisture. This function is for authorized users only.

Description of each MENU function

1. Recall

This function allows you to retrieve and review the most recent test data.

1. Press the **MENU** button.
2. Press the **1** button.
3. You can now scroll through the test information.

2. Offset

There are three offset options in the gauge: Density, Moisture, and Trench.

1. **Density** - allows the addition or subtraction of a given quantity from the wet density (WD) readings measured by the gauge. This function can be used for correction of the gauge readings to other test methods, such as asphalt cores tested by water displacement method.
2. **Moisture** - corrects the gauge moisture readings to oven or speedy dry moisture.
3. **Trench** - corrects for the effect of trench walls to gauge moisture readings.

To use the offset mode:

1. Press the **MENU** button.
2. Select the **2** button.
3. Scroll **UP** or **DOWN** to the offset you want to enable.
4. For entering a negative number use the **DOWN** button, for a positive number use the **UP** button.

Density Offset - use this function to offset the density up or down by a known quantity. For example, if the gauge's wet density (WD) is 142.0 PCF and the actual field density is 145.0 PCF, use a density offset of 3.0 to correct the gauge readings. The offset value can be positive or negative. The UP key is for the (+) sign and the DOWN key is for the (-) sign. Follow gauge prompts to enter this value.

Note: When density offset is enabled a Y on the gauge ready screen will appear next to offset.

Moisture Offset - This function provides a means for correction of gauge moisture results to results obtained by oven dry, speedy

dry or other laboratory drying methods. Use the following equation to calculate the correction and enter this value into the gauge when prompted by the software.

$$K = \left(\frac{\%M(\text{True}) - \%M(\text{Gauge})}{\%M(\text{Gauge}) + 100} \right) \times 1000$$

Where %M (Gauge) is the gauge derived % Moisture (%M) value with K=0 (no moisture offset, factory calibration) and %M (True) is % Moisture determined by oven dry, speedy dry or other laboratory methods.

Once the K value is entered in the gauge, all subsequent test results for moisture will be corrected by this offset. Use the **UP** key for (+) sign and the **DOWN** key to enter (-) sign.

Note: When moisture offset is enabled a Y on the gauge ready screen will appear next to offset.

Trench Offset - This function provides a means for correction of wall influence on gauge moisture counts. Use this offset function when taking measurements in a trench with walls 1 meter (3 ft.) or less from the gauge.

To use this function, take a standard count on the reference standard block outside the trench and record the moisture standard count, MS. Place the gauge on the standard block in the center of the trench with the handle parallel to the wall in **SAFE** position. Then press **START**. The gauge will automatically calculate the Trench Offset by the equation

$$\textit{Trench Offset} = MS - M \textit{ Count}$$

The gauge is now in Trench Offset mode and ready to test.

Note: If M Count is lower than MS, then there is no influence from the trench walls and trench offset is not necessary.

Note: When trench offset is enabled a Y on the gauge ready screen will appear next to offset. Once a test begins, "T" will appear on the screen, indicating Trench Offset mode.

3. Auto Scroll

The Auto Scroll feature allows for hands-free operation of the gauge after a measurement has been obtained. When this feature is enabled the test results will scroll from screen to screen without the need to push the up or down buttons.

To enable this function:

1. Press **MENU**.
2. Press the **3** button for Auto Scroll.
3. Press **YES** to enable the feature.

After a measurement the screen will remind you that Auto Scroll is enabled and after a few seconds the screen will change to the results. Every 5 seconds the screen will display the next set of results. Press the **START/ENTER** to begin a new measurement.

Note: Powering the gauge off will disable Auto Scroll

4. LCD Backlight

This feature allows for use of the gauge during night work. The backlight will stay lit on the display and keypad for approximately 20 seconds after a button is pressed.

To enable this feature:

1. Press **MENU**.

2. Press the **4** button.
3. Press **YES** to enable.
4. To disable the feature repeat steps 1-4. The gauge will prompt to disable the backlight if it is on, pressing **YES** will disable the backlight.

Note: Powering the gauge off will disable the backlight feature.

Note: The backlight on the gauge causes a larger drain on the batteries than under normal use. Only use backlight during night work and when necessary.

5. Diagnostic Test

This function should be performed by a train technician and under InstroTek's instructions. In this mode the gauge can check the following components and functions of the gauge: Battery Voltage, High Voltage, Temperature, Reset Memory and test the depth sensors.

Battery Voltage

This function measures and displays the total voltage on the 6 AA NiMH batteries. The maximum measurable voltage on the battery packs is approximately 9 volts.

The low voltage indicator comes on at 7.0 volts and the gauge will shut off at 6.6 volts. Based on the condition of the batteries and the usage, the gauge has a full day of use from the time of low battery indication to shut off. Use the car charger adaptor (DC charger) for charging the batteries in the field.

High Voltage

This function measures the high voltage on the board. This information is very important for trouble shooting the gauge and enables our technicians to provide instructions on the status of the gauge. Please note, this measurement will not be available on Smart-MC with the old density and moisture modules.

Check Temperature

This function measures the temperature in the gauge to determine if inconsistency in results is due to high temperature. This information is very important for trouble shooting the gauge and enables our technicians to provide instructions on the status of the gauge.

Memory Reset

Only a trained service technician should do this; it will render the gauge nonoperational and may require the gauge to be returned to InstroTek. This function is used in case the gauge requires extensive work or repair. Memory clear erases all stored information and in effect resets the gauge to pre-calibration factory defaults. The calibration constants will need to be re-entered into the gauge.

Depth Sensor Test

This function measures the magnetic sensors at each depth to ensure they are operational. This information is very important for trouble shooting the gauge and enables our technicians to provide instructions on the status of the gauge.

6. Drift Test

If there a consistent drift in the standard counts from count to count or day to day, the electronics may have a drift problem. This test monitors the long-term drift of the gauge. The drift test

consists of performing five 240-second counts. To obtain a meaningful drift result, first take a Stat Test (please refer to the Stat Test) and wait 3-4 hours before starting a drift test. The average of the five drift moisture and density counts is compared against the average of the 20 one minute Stat test averages. Passing limit on moisture is equal to 1.0% or less and density is equal to 0.5% or less.

1. Perform a Stat Test on the gauge.
2. Wait 3-4 hours, and then begin the next steps. The gauge may be used during this time, but if the gauge is not functioning correctly, then it would be best not to use it to obtain measurements.
3. After 3-4 hours, set the gauge back on the standard block. Make sure the source handle is in the "SAFE" position.
4. Press the **MENU** button. Press the **6** button.
5. Press **START**.
6. After 20 minutes, the results will be displayed.
7. If the gauge indicates a failing percentage, then contact your InstroTek representative.

Note: Control the movement of other gauges during this test. Always keep other gauges a minimum of 10 meter (30 feet) away, while taking a Drift test.

7. Stat Test

A Stat Test may be performed to validate the normal operation of the gauge electronics. If two out of three stat tests fail the limits set in the gauge, contact your InstroTek representative. Passing limit on stat test results are $R=0.25$ to $R=0.45$.

To perform a Stat Test:

1. Press **MENU**.
2. Press the **7** button to do the Stat Test.
3. Place the gauge on a standard block on a level dense surface, such as soil, asphalt or concrete. Make sure you are 30 feet (10 meters) away from other gauges.
4. Place the source rod in the "SAFE" Position.
5. When the display reads Stat Test, press **START**.
6. After 20 minutes the display will show the results of the test, you can scroll through to see each count.
7. If the test fails, repeat the test. If two out three tests fail, contact your InstroTek representative.

Note: Control the movement of other gauges during this test. Always keep other gauge a minimum of 10 meter (30 feet) away, while taking a Stat test.

8. Auto Depth

The Elite gauge is equipped with an automatic non-contact magnetic depth indicator. This function will disable the automatic depth mode, if desired. If Auto depth is disabled,

the gauge will prompt before every reading to manually enter a depth.

Under this function, you can calibrate the depth sensors. In a rare case, they may fall out of calibration.

Under Auto Depth function, select **1** to Enable/Disable the Auto Depth, or **2** for Calibration and follow the screen prompts.

9. Review Standard (STD) Counts

The Elite gauge stores the last 30 standard counts and the date of measurement. Use this function and the **UP** or **DOWN** key to scroll through all the standard counts. A record of this data can be downloaded by inserting a USB drive in the gauge and pressing the **STORE** key. The standard counts will be stored in the USB drive for future use.

10. Select Language

Elite is currently designed to work in two languages, English and Spanish. (Press **1** then **0**) Select **1** for English and **2** for Spanish.

11. Set Units

This menu function allows the gauge to set the default units to pounds per cubic feet (PCF or lb./ft³), kilograms per cubic meter (kg/m³), or grams per cubic centimeter (g/cc). The MA/PR will need to be entered in the same units as the default selection. Depth will be based on the units you select: either inches for lb./ft³ or millimeters for kg/m³ or g/cc.

To set this option:

1. Press **MENU**.
2. Press the **11** button (**1** then **1**).
3. Select PCF, kg/m³, or g/cc with number keypad.

12. Standard Mode

Two different Standard Count Modes can be selected and used with the MC3 Elite, Average Mode and Decay Mode. The gauge default is the Average Mode. In the Average Mode, the percent change between the current standard count and the average of the last four standard counts taken by the gauge is displayed. The current standard count is used to calculate the results of the Density and Moisture content.

The second mode is the Decay Mode. In this mode, the elapsed time from the date of calibration is calculated and the calibration density standard count is corrected for the Cs-137 decay. Cs-137 used in the gauge for density measurement decays approximately 2.2% per year. The corrected calibration standard count is compared to the daily standard count. The Pass/Fail limit is set at $\pm 1\%$ of the decay corrected calibration standard count. This calculation is done automatically by the gauge and Pass/Fail limit is displayed. To ensure proper results in this mode, the calibration date and calibration standard count stored in the gauge has to be correct and current.

13. Serial Number

This function enters the serial number of the gauge to be entered. This is set at the factory. Only authorized technicians should use this function.

14. Date/Time

This function sets the date and time.

15. Buzzer/Alarm

This function enables or disables the Buzzer/Alarm. When this function is enabled the gauge will beep when a key on the keypad is pressed. Also, the gauge will sound an alarm after completion of a test count.

16. Special Calibration

Special calibration provides the functionality to adjust the factory calibration in the field. Special calibration constant, B, can be derived by the gauge, or may be entered by using the equation given in this section for calculation of B.

The gauge is calibrated at the factory to "average soil", which is defined as material that is half way between pure granite and pure limestone. For most soil and aggregate materials, average soil approach results in accurate density measurements. However, there are cases when the material composition being tested is much different than the range of materials covered by the factory calibration. Special calibration provides the user the opportunity to calibrate the gauge to local materials and materials not covered by the factory calibration.

In the special calibration mode, a new B constant is calculated by using an actual field sample and obtaining the "true density" of the sample. The B value is the only constant in the gauge that is influenced by the material composition. So changing this constant is the most effective way to account for material composition changes in the field.

To perform a special calibration for a local material that may not be covered by the factory calibration, take a minimum of four and a maximum of 10 density counts in the field on the material the gauge is to be used on. For granular materials, use direct transmission readings and for asphalt, use BS readings.

Average the counts. Obtain samples from the locations where gauge reading are taken. Analyze the samples in the lab and determine the density of the material ("True Density") in kg/m³. Use the following equation to recalculate the B value that will be entered in the gauge.

$$B_{Special} = \frac{\text{True Density}}{\ln\left[\frac{A}{CR - C}\right]}$$

Where CR is count ratio (Average count/std. count) determined by the gauge in the field, A and C are calibration constants for the depth of measurement used in the field and True density is density determined by a conventional method in the lab.

Note: The gauge can perform the calculations if counts and true density values are determined and input in the gauge software. Furthermore, the gauge software is written so that the entire special calibration function process, including collection and storage of counts, is performed by the software. Follow gauge instructions to perform Special Calibration.

To use the Special Calibration Function:

Press **MENU**:

15. Buzzer Alarm
16. Special Cal.
UP/DOWN for Next
Select #, ESC Exit

Press **1 THEN 6**

Enable Special
Calibration?
Press YES or NO
ESC to Exit

Press **YES** to Enable Special Calibration and **NO** to go back to the gauge ready screen.

Use Gauge to Derive
B Value?
Press YES or NO
ESC to Exit

Note: If special calibration has been used previously, the gauge will ask if the same calibration or previously stored data should be activated. At this point, the previously used special calibration may be activated or select to start a brand new special calibration.

At this point, the gauge provides the option to derive the Spec Cal constant B or entering the constant previously derived. When 'Yes' is selected, the gauge will prompt to select the number of counts required to take on the material. It is recommended that a minimum of four and maximum of ten readings are selected for this test.

(Select 1 to 10 readings)

Enter Number
of Counts: ##
ENTER to Accept
ESC to Exit

Depth: BS
UP/DOWN TO CHANGE
YES to Accept
ESC to Exit

Select the number of counts and desired depth.

Place the gauge on the material at a desired location and press start to accumulate the first count. The gauge will prompt you to take counts until the selected number of counts has been completed. Record each individual count taken. Even though these counts are not needed for gauge derived calculations, it will provide you with a record of this data. It is recommended that the gauge be moved to a new test location for each one of the counts. Follow the screen prompts to complete the counts.

After all counts are accumulated, the gauge will average all counts and will ask you for the "True" material density. "True" density is achieved by collecting a representative material sample from the field and analyzing this material in the laboratory by using a conventional density test. You may also consider using other test methods such as sand cone and balloon methods in the field for determination of "True" density, if specified by local agencies or specifications.

If you have the "True" material density, you may enter it at this time. Otherwise, you may enter this value at a later time. The gauge will save the counts for use at a later time. If you select 'Yes', the gauge will prompt you for density input.

Enter Value For
Density Now?
Press YES or NO
ESC to Exit

Enter Value for
Density= ## PCF
ENTER to ACCEPT
ESC to Exit

Once the density is entered, the gauge will calculate a B value and go into the Special Calibration mode. Record the B value. During measurements Special Calibrations will appear on the screen to indicate that the gauge is in special calibration mode. If the operator turns off the gauge, Special Calibration is automatically disabled and factory "normal" calibration is activated. The gauge will maintain the previous B value until it is over written by a new special calibration test.

Note: If operating in g/cc mode, the gauge will prompt to enter the density in kg/m³ (g/cc x 1000).

Important: Record and save the B value for future use. Having the B value eliminates the necessity of going through the gauge derived process.

It may be more practical to enter the density at a later date. If a density value is not entered after taking counts on the material, on the next Special Calibration, the gauge will prompt to use the stored data. This data contains the counts taken on the most recent use of Special Calibration function.

Value B may be entered directly into the gauge special calibration function if available from previous calculations.

To enter the B value, press **YES** to activate the special calibration.

B=#####
Activate Special
Calibration?
Press YES or NO

17. Nomograph

The Nomograph function allows for measurements of thin overlay density on asphalt or concrete. Do not use this mode for asphalt on asphalt or asphalt on concrete surfaces. The use of regular BS mode will produce more repeatable results on asphalt and asphalt on concrete projects. Since the density variation between the top and bottom material for asphalt on asphalt and asphalt on concrete pavements are minimal, use of the Nomograph mode does not guarantee more accurate results. The influence from the bottom material is masked by the top material density and the results of the Nomograph mode and BS mode will not be different. Only use the Nomograph mode for parking lots or projects with asphalt on top and soil or aggregate sub base on the bottom. Under these conditions, Nomograph mode results will be more accurate than the BS mode of the gauge.

To use the Nomograph mode, place the source in the BS position. Obtain the top material thickness and the density of the material immediately under the thin overlay. The equation used for calculation of the overlay density is:

$$DT = \frac{WD - DB \times K}{1 - K}$$

Where DT is the overlay density, WD is the wet density measured by the gauge and K is the effect of the top layer on the density measurement. K is dependent on top layer material thickness and is defined by:

$$K = a_{11} \exp(-a_{12} X) - a_{13}$$

X is the top material thickness and a_{11} , a_{12} , a_{13} are constants derived at the factory.

The gauge software automatically performs Nomograph calculations. To use this function, select the menu item and press the **17** button.

Enable Nomograph
Mode?
Press YES or NO
ESC to Exit

Select **YES** to enable the Nomograph function. Follow the screen prompts to enable the Nomograph mode.

Enter Nomograph material thickness in inches or mm, depending on the unit already selected in the gauge. The range of thicknesses that can be used with this function is 1 to 3.5 inches (25 to 90 mm). Do not use this function for thickness outside this range, as the results will not be accurate.

Enter Material
Thickness: ## in
ENTER to Accept
ESC to Exit

Enter the density of the material immediately under the top material. To obtain this density, use the gauge to measure the material density prior to construction of the overlay.

Enter Bottom
Density: ## PCF
Enter to Accept
ESC to Exit

Once bottom material density is entered, the Nomograph mode can be activated. During measurements, "Nomograph" is displayed to indicate Nomograph is active. If the gauge is turned off, the Nomograph mode is disabled. Enable this function again through the menu by following gauge prompts and activating the most recent saved data.

The most recent Nomograph function inputs will remain in the gauge until a new set of thickness and bottom density data is entered for a new job.

18. Calibration Constants

This function will require an access code. Contact your RSO or InstroTek to obtain an access code.

Note: Only someone familiar with nuclear gauge setup and calibrations should perform these steps. Changing this information will result in erroneous readings.

To enter calibration constants:

1. Press **MENU**.
2. Press the **18** button (**1** then **8**)
3. Press **ENTER**.
4. Enter access code using the number keypad.
5. Press the **0** button to change the Moisture constants (E and F) for entering a negative number use the DOWN button, for a positive number use the UP button.
6. The depths will be displayed. Scroll to the desired depth and press the corresponding number for desired depth. A, B, and C constants can be set for each depth. Use the **DOWN** key to enter (-) sign. After all depths have been entered and you are back at the select the depth screen, you can press the **ON/YES** button to take you back to the gauge ready screen.
7. If the gauge units are in PCF, the calibration constants are displayed and entered in PCF. If the gauge units are in kg/m³ or GCC, the calibration constants are displayed and entered in GCC. There may be rounding errors when switching between units.

Other Features of the Model MC-3 Elite

Note: Only trained technicians should perform these functions.

The Reset Button - This button will reset the operating program. If the program freezes or stops responding, then pressing this once will reboot the system. The gauge will not lose calibration constants, standard counts, or last measurement. However, the LCD back light and Auto Scroll set will need to be re-enabled. The scaler will need to be removed from the gauge to use the reset button. Simply unscrew the four screws on the front of the panel, lift out of the housing, and turn over the scaler. The reset button is on the top of the scaler circuit board. See *Fig 3.1*

RS-232 - This connection will download the constants into the gauge with the aid of the computer software. Please contact InstroTek, for more information.

J-45 - This connection is only used at the factory to program the system software used on the Model MC-3 Elite. **Do not plug any wires to this connection, as it could damage the scaler and will void any warranty in effect on the gauge.**

Display Contrast - This dial sets the contrast of the LCD; this can be changed to the liking of the user. Using a small screwdriver, adjust the contrast level.

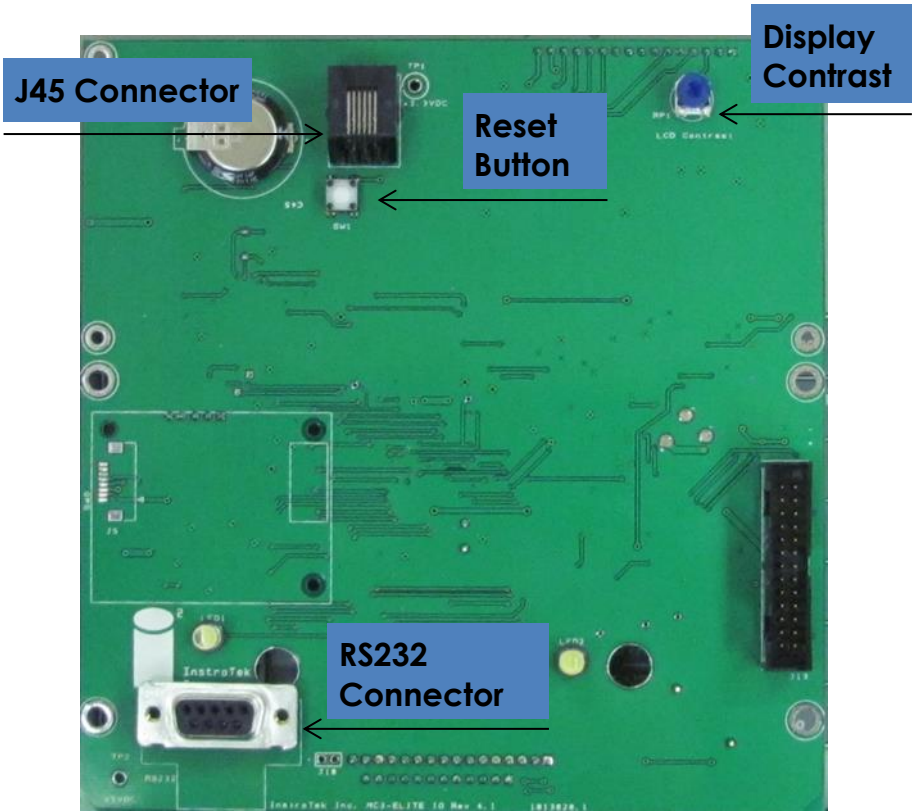

Fig 3.1 Backside of the Front Panel circuit board

4. Radiation Theory

This chapter covers information on basic atomic physics. It is important that the users have an understanding of this section in order to have a handle on applications and safety related issues.

Elements/Atoms

Elements are combinations of the three sub-atomic particles: Protons, Electrons and Neutrons. Each element has unique chemical properties. Typical elements are Silicon, Oxygen, Gold, Copper, and Iron. Currently 118 primary elements have been identified, 90 natural, the rest man made. A few of the elements have been created only in the laboratory, but they decay very quickly.

Atom is a Greek word for indivisible. The simplest element/atom is hydrogen. It has one proton, no neutrons, and one electron. A more complex element is oxygen that has 8 protons and 8 neutrons in the nucleus, and 8 electrons in orbit.

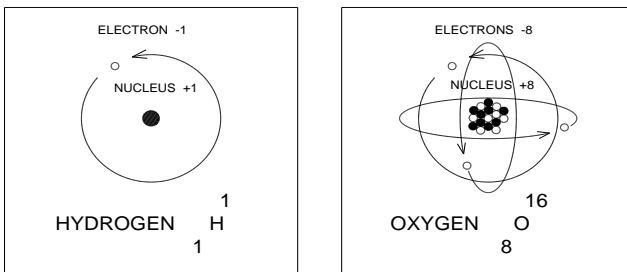

Fig 4.1 Examples of Atoms

The atom is not solid, it is mostly space. If the nucleus of hydrogen was the size of a marble and placed on the 50 yard line of a football stadium the electron would be the size a pinhead in the stands.

Each element/atom has been assigned a one or two letter symbol that is an abbreviation of its name (generally Latin).

<u>Symbol</u>	<u>Latin</u>	<u>English</u>
Au	Aurum	Gold
Cu	Cuprum	Copper
Fe	Ferrum	Iron

The atomic number (Z) is the number of protons in the nucleus

The mass number (A) is the sum of the protons and the neutrons in the nucleus.

Isotopes

Elements that have the same number of protons (same atomic Number), but different numbers of neutrons (different atomic mass numbers) are called Isotopes. Hydrogen has three isotopes. The most abundant hydrogen isotope has one proton and no neutrons. The isotope of hydrogen with two neutrons is called Tritium and is unstable. Tritium is produced in the atmosphere by neutron bombardment of nitrogen.

Earth's Crust

Our task is to measure the density of soils. The elements in the periodic table we are concerned with are those in the earth's crust.

ELEMENT	SYMBOL	No. (Z)	MASS (A)	Z/A	% EARTH'S CRUST
Oxygen	O	8	16.00	0.5000	49.9%
Silicon	Si	14	28.09	0.4984	26.0%
Aluminum	Al	13	26.98	0.4818	7.3%
Iron	Fe	26	55.85	0.4655	4.1%
Calcium	Ca	gamm 20	40.08	0.4990	3.2%
Sodium	Na	11	22.99	0.4785	2.3%
Potassium	K	19	39.10	0.4895	2.3%
Magnesium	Mg	12	24.31	0.4936	2.1%
Other					2.8%
Hydrogen	H	1	1.008	0.9921	
Water	H ₂ O	10	18.016	0.5551	

The density of a material is dependent upon its atomic mass (A). But the count rate in the nuclear density gauge is dependent on the number of electrons (atomic number (Z)). For the most materials in the earth's crust this presents no problem since the ratio of the atomic number to the atomic mass (Z/A) is approximately 0.5.

Radioactivity

Not all isotopes are stable. Isotopes with atomic numbers greater than 92 are unstable. Americium used for moisture measurement in the nuclear gauge has an atomic number of 95. It is a by-product from neutron bombardment of Plutonium to produce weapons materials. All 13 isotopes of Americium that have been identified are radioactive.

Some isotopes of lower atomic number are also unstable; Cesium-137 used in the nuclear gauge for density measurement has an atomic number of 55. Of 22 isotopes identified, Cesium-133 found in nature is stable, while Cesium-137, a by-product of making atomic weapons materials, is not. By nuclear reactions, man has produced a large number of unstable isotopes not found in nature.

Any unstable isotope that gives off energy—while decaying to a stable isotope—is defined radioactive. Like other forms of energy, radiation can be useful or harmful depending upon its use.

Alpha, Beta, Neutron, and Gamma Radiation

Sources used in the nuclear gauge are composed of four types of radiation: Alpha particle, Beta particle, Photons (gamma rays), and Neutrons.

Alpha Particles travel only about an inch in air and are stopped by a sheet of paper or the skin tissue. In the nuclear gauge, alpha particles are used to produce neutrons.

Beta particles travel a few feet in air and are stopped by an inch of wood or a thin sheet of aluminum or plastic. In the nuclear gauge beta particles are stopped by the source containment.

Gamma rays travel hundreds of feet in air and can be shielded by thick lead or concrete.

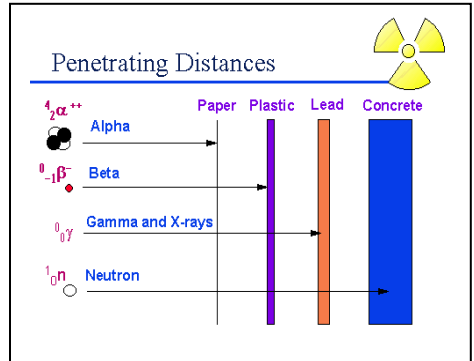

Fig 4.2 Penetrating Distances

Neutron particles travel hundreds of feet in air and can be shielded by water, plastic, or special concrete.

Cesium-137 and Americium-241/Be are used in the Elite portable moisture/density gauge and they produce all four types of ionizing radiation. The alpha and beta radiation will be stopped by the stainless steel source containment. Only neutron and gamma radiation contribute to occupational radiation exposure.

Neutron radiation

Neutron radiation in the Elite gauge is produced by alpha particles from the Americium 241 bombarding the Beryllium. Neutron radiation has no charge and is very penetrating. To shield against neutron, the first step is to slow down the neutron, which is called thermalization. Thermalization is achieved by interaction of neutron with particles of same mass as neutron, like hydrogen in water or polyethylene. As neutrons collide with these particles, neutron energy is reduced allowing for effective absorption by the shielding material.

Gamma radiation

Gamma radiation is electromagnetic radiation that is released from nuclear reactions. X-rays, radio waves and light are some other examples of electromagnetic radiation. Gamma rays and visible light have no electrical charge or mass and travel at speed of light. Unlike visible light, gamma rays are very energetic and can penetrate several inches of solid material. The gamma source in the Elite gauge in the process of decaying to Ba-137 releases beta particles which will be stopped by the capsule wall. The Cs-137 releases gamma ray energy of 0.662 Mev. This gamma energy is used to determine the density of the material.

Half-Life

An important characteristic of radioactive material is that its activity decays with time. The half-life ($T_{1/2}$) of a radioactive material is the time it takes for half the atoms in any given mass of the material to decay. Half-lives vary from fractions of a second to millions of years. After ten half-lives only 1/1,000th of the radioactivity remains.

The two sources in the MC-3 Elite model are Cesium-137 for density measurements and Americium-241/Be for moisture measurements. Cs-137 has a half-life of 30 years, while Am-241 has a half-life of 432.2 years.

To correct for decay, a standard count is taken each day of use and the ratio of the measured count on a material to the standard count, defined as Count Ratio, is obtained. The count ratio automatically corrects for any decay in the source when making a density measurement.

5. Radiation Safety and Health Physics

This chapter covers information on health physics and radiation safety concepts.

Terms

Roentgen The Roentgen is equivalent to 1 electrostatic unit of charge from interaction of gamma radiation in 0.001293 gram of air at 1 atmosphere pressure and is a unit of exposure.

RAD The Roentgen has limited use since it does not consider the dose effects of the radiation. Initially, it was replaced by Radiation Absorbed Dose, and is a unit of dose.

Rem The RAD only applied to air so it was soon replaced by Rem. The Rem includes the biological effectiveness of the radiation type. It is related to the RAD by its Relative Biological Effectiveness (RBE) or Quality Factor, and is a unit of dose, referred as equivalent dose.

Quality Factor (QF)

Quality factor takes into account the differences in biological effect of different radiation. For example, QF for X-ray and gamma rays is 1, 20 for alpha particles and 10 for high energy neutrons.

Natural Radiation

The best way understand the Rem is to know it relates to our everyday life. Annually humans are exposed 100 to 300 mRem (milliRem) per year from natural sources:

Source	Description	Annual Dose
Cosmic	From the sun and other space sources and their reaction with the earth's atmosphere. It increases 1 mRem for every 100 ft. of elevation above sea level. - San Francisco (Sea Level) - Denver (5,280 ft.)	- 44 mRem - 97 mRem
Earth	From the natural radioactive materials in the ground	-15 mRem
Housing	From the materials used to build our homes and work places: - Stone house - Brick or concrete - Wood house	- 50 mRem - 45 mRem - 35 mRem
Living	- Eating/Drinking/ Breathing - Body - Television (2 hours per day) - Jet plane trip (3000 mile flight)	- 25 mRem - 15-20 mRem - 0.3 mRem - 2 mRem

Man	- Weapons testing fallout - Medical X-rays - Nuclear Moisture/ Density Gauge	- 4 mRem - 9-210 mRem - 25 mRem/yr.
-----	---	---

Fig 5.1 Natural Radiation and Annual Dose

Typical yearly totals are 123 mRem for someone living alone in a wood house in San Francisco, and whom does not; fly, get sick, or watch television, and 272 mRem for someone living in a stone house in Denver, flying coast to coast 10 times per year, watching television 4 hours per day, and getting one dental X-ray (20 mRem).

There is no evidence to suggest that people living in regions of higher natural radiation have poorer health as a result. Some of the longest living people in the world live in high mountain regions. (In areas of Brazil and India the natural radiation is ten times greater than the average in other parts of the world).

The exposure limit set by the United States Radiation Protection Authorities is 5000 mRem per year for radiation workers.

ALARA

As Low As is Reasonably Achievable considering social and economic matters.

No matter what the allowable legal limits are, the operator and his company should review their procedures to determine if with reasonable steps the dose could be reduced. This should be taken considering all aspects, e.g. one could design a density/moisture gauge with sufficient shielding that little or no

radiation escaped, but it would be so heavy that it would not be a practical portable gauge.

The three ways the operator has to reduce the dose:

- Time** Minimize the time of exposure
- Distance** Do not get closer than necessary
- Shielding** Place a shield between the source and the operator. The gauge has shielding installed

ALARA is another way of saying: Use common sense.

Time

When the operator is using a radioactive source, he is in a radiation field from that source. Reducing the time spent with the gauge significantly reduces the radiation dose received by the operator. The strength or dose rate of that field is measured in mRem per hour. For a given dose rate and time in the field the operator will receive a dose.

$$Dose = Dose\ Rate \times Time$$

LESS TIME = LESS DOSE

Distance

Distance is one of the most effective ways to reduce radiation exposure. Radiation starts from a point source and as the distance increases spreads out on a spherical surface. Its intensity at any distance from the source depends upon the square of the distance from the source.

$$I_1 \times (D_1)^2 = I_2 \times (D_2)^2$$

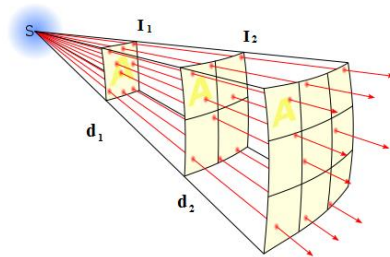

Fig. 5.2 Distance

Doubling the distance will reduce the dose rate to one-fourth. Cutting the distance in half will increase the dose rate by four times.

Shielding

Shielding is an effective way to reduce radiation exposure. Alpha particles can be stopped by a single sheet of paper; however, gamma and neutron radiation cannot be completely stopped by shielding, but can only be reduced. Polyethylene—which contains a very high concentration of hydrogen—is usually used for shielding neutrons. Lead or tungsten is used for shielding gamma rays.

MORE SHIELDING = LESS DOSE

Regulations

Since radioactive material can be hazardous to the public if not used properly, its possession and use is controlled by regulatory agencies. These are either the Nuclear Regulatory Agency (NRC), or if an agreement state, your state agency.

License

To possess and use radioactive material, the organization, corporation, partnership, or individual user must obtain a specific radioactive material license. When the organization applies for a license, it must specify the type, form, amount, and use of the radioactive material.

Radioactive Material Amount	Form	Amount	Use
Cesium-137	Sealed Source	Not to exceed 11 mCi per source	For use in InstroTek MC-3 Elite Moisture/
Americium-241/Be	Sealed Source	Not to exceed 55 mCi per source	Density Gauge

The quantity specified under amount is the **MAXIMUM** activity which shall not be exceeded for a single source. Furthermore, you should ensure that the storage is adequate in space, shielding, and restricted access for the number of gauges you requested in your license.

The requested use should be as general as possible, since the actual use will be limited to the specific applications stated in

the license. Unless stated so, the gauge cannot be used to do things like helping your child do a science projects.

Leak Testing

Portable moisture density gauges use radioactive material that is double encapsulated in stainless steel identified as special form. The probability of such a sealed source leaking is very remote. To verify that the sealed source is not leaking the gauge must be tested periodically.

A gauge should be checked upon its receipt to see that its leak test is current and should not be used unless it is current. A new test must be taken within twelve (12) month period. A leak test kit has a swab or patch which is moistened, wiped around the source area, placed in a plastic bag and then mailed to a lab for analysis. A source is considered leaking if more than 0.005 microcurie of removable contamination is found. A copy of the leak test certificate should be kept with the gauge and a second copy in the RSO's files available for inspection by the regulatory agency. If the user has several gauges it is more convenient if they are all tested at the same time, e.g. the first working day of January and July.

Personal Monitoring

Dosimetry (measurement of the dose to an individual) is required if the expected dose is 10% or more of the allowed occupational dose of 5,000 mRem in a year. Most licensing agencies require personal monitoring for their operators. Proper use of a moisture/density gauge will result in a dose less than 1% of the allowed dose, but most regulatory agencies take the position that it may be exceeded if improperly used and thus require dosimetry. Dosimetry is also used for long-term legal protection to the licensee.

Training

Persons using devices containing radioactive materials must be trained in the safe use of the gauge by completing an approved course offered by an organization licensed to provide training. In some large organizations the Radiation Safety Officer is trained and licensed to conduct the course.

When in the field, the user must have available for inspection:

- Copy of the shipping papers or Bill of Lading,
- Copy of the Emergency Response form with the shipper's emergency contact number,
- Copy of Gauge Operator's Manual,

Notify the regulatory agency of any incident or condition that might be hazardous to the user or the public. For gauge users this includes:

Immediate: Accident involving possible dispersment of radioactive material, or theft, or loss. Total Effective Dose Equivalent >5 Rem, loss of equal or greater than one week of operations, damage to property of greater than \$200,000

24 Hour: Exposure of an individual to 5 Rem or more, Accident resulting in the loss of one or more days operation, or
Damage to property is excess of \$2,000.

30 Day: Exposure of an individual in excess of the allowable dose: Occupational exposure of 5 Rem, dose to embryo/fetus during entire pregnancy to declared pregnant women 0.5

Rem, dose to individual member of the public
0.1 Rem per year.

Safety Plan

As part of the license, each organization must have a Radiation Safety Plan that describes procedures to be followed and what to do in case of; fire, theft, and/or accident.

Radiation Safety Officer (RSO)

The licensee must designate some person in the organization as the Radiation Safety Officer (RSO). The RSO is the contact point for the regulatory agency to see that the regulations are followed. The RSO is the person in the organization responsible to see that safe practices are followed and that the proper records are maintained. Designating an RSO does not relieve the owner/officers of the ultimate responsibility.

Notice to Employees

A "Notice to Employees" is a document issued by the regulatory agency. Normally safety problems would be reported to the organization's Radiation Safety Officer or a manager. This document contains addresses and/or telephone numbers for employees to contact if they are not satisfied with the organization's response.

Transfer

The gauge should not be transferred to another party for service, disposal, sale, or use unless the other party is authorized to receive the appropriate radioactive material. Always remember that the “transferor” (the licensee) has the responsibility to obtain a copy of the “transferee's” license or obtain an official attestation that they are able to receive that particular type, form, and quantity of radioactive materials. The best way to establish authorization is to have a copy of the other parties' radioactive material license. Look at paragraphs 6, 7, 8, and 9, for type, form, amount, and use, and verify that the license has not expired. The regulations provide that if the user applies for renewal within 30 days of the renewal date, the license is considered in “Timely Renewal” until the regulatory agency issues a new license. If this is the case, along with the copy of the license get a copy of the Timely Renewal Letter from the regulatory agency or a statement from the other party.

Temporary Storage

Use of the gauge will involve removing it from its storage location described in the license and bringing it to job sites and other locations to test materials. The end user is responsible to verify requirements with the appropriate US NRC or Agreement State regulatory agency prior to establishing a Temporary Storage location. Normally the gauge will be returned to its permanent storage location listed on the license each evening. Sometimes it will be stored in temporary locations, for example, in a trailer on a job site. This storage location should follow the same rules for security, posting, safety, and charging as the permanent location. If the gauge will be in the temporary location for longer than 30 days, the regulatory agency should be notified by letter/FAX. If it will be longer than 180 days the

license should be amended. The gauge should not be left in an improper storage location at the job site or in your home.

Reciprocity

Radioactive material may be used in another licensing jurisdiction on a temporary basis. The other licensing jurisdiction must be notified in writing at least 3 days in advance. It can be a letter describing the device, the amount and type of radioactive material it contains, the location the gauge will be used, and the duration of the intrusion. Attach a copy of your license.

If it will be for more than 180 days in any calendar year then it is necessary to get a license in the other jurisdiction.

Service/Maintenance

Service and maintenance is a part of the Radiation Safety Plan of any organization. Prior to each use, the integrity of the shutter should be checked. If a source rod becomes stuck in the transmission or exposed position, it is considered an exposed source.

The gauge will require cleaning of the shutter block area, depending on the type of soil and number of tests. To minimize exposure, face the base of the gauge away from you, allowing the body of the gauge to act as a shield when you remove the shutter. Use compressed air or a long handled brush to clean out the shutter area. Although the probability is very low of there being removable contamination, there is no justification to wipe the rod with the bare hand.

Note: The dose at ¼ inch from the source of an exposed source rod is approximately 70 Rem/hr.

Disposal

Radioactive material is defined as a hazardous substance. It should not be disposed of without considering others. When the gauge is no longer needed or useful to the organization, it is best to transfer the ownership out of the organization. A disposal broker such as a manufacturer may take the gauge back for a fee. In all cases, the recipient must be properly licensed.

6. Transportation

This chapter covers the necessary requirements for transporting the gauge to job sites and from one facility to another.

General Awareness

The transportation of hazardous materials is regulated by the U.S. Department of Transportation. This includes the transportation of the radioactive material as contained in portable moisture/density gauges in private vehicles on public highways. The regulations are published in the Code of Federal Regulations, 49CFR100-177. Copies of this publication are available from the US Government Printing Office. They are updated in October.

Note: The regulations define any employee that is involved with the transportation of hazardous materials, as a HAZMAT employee, and requires that they receive appropriate training by the HAZMAT employer. This training must take place within 90 days of hire or transfer, and must be current within three years. The employer is responsible to maintain records of training and testing.

Specific Functions

Shipping Name

Table 172.101 of 49CFR100-177 contains a list of hazardous materials. The gauge contains radioactive material double encapsulated in stainless steel capsules and designated as Special Form. The proper shipping name selected from this list in the table is:

[RQ] Radioactive Material, Type A Package, Special Form, 7, UN 3332

Special Form describes a sealed source with minimum possibility to disburse contamination in an accident. This must be certified by a document which is maintained on file for at least one year after the latest shipment (e.g. the last time the gauge was transported in the company vehicle on a public highway). Normally it will be supplied by the gauge manufacturer. If you have gauges from more than one manufacturer you must have a certificate from each. A copy of an IAEA Certificate of Competent Authority as described under International Air Shipments can be used to satisfy this requirement. Class 7 applies to Radioactive Material. UN3332 is an assigned number which allows quick selection in reference manuals.

Reportable Quantity

49CFR requires that shipments of quantities of hazardous materials above certain levels are marked RQ and must be reported to the EPA in the event of an accident that results in a release of radioactive material. For the radioactive materials in the gauge per 172.101 App Table 2, the reportable levels are:

- Cs-137 1,000 mCi
- Am-241 10 mCi

8 and 10 mCi of Cs-137 is not a reportable quantity, but 40 and 50 of Am-241 is a reportable quantity. For a reportable quantity, RQ must be included before the description. The shipping name label on the package must include the RQ.

Packaging

The package the gauge is shipped in, must meet certain requirements. For radioactive material in Special Form, a Type A package is appropriate. The package or a prototype must be tested and a copy of the Type A Evaluation Report and Certificate maintained on file for at least one year after the latest shipment. This document will normally be supplied by the gauge manufacturer. The manufacturer must also provide a Closure Instructions document for the Type A package. This document should be kept in the gauge case at all times. The Type A tests include; water spray, free drop, corner drop, compression, and penetration test.

Labeling

A radioactive label must be selected from the following:

RADIOACTIVE	Dose rate at package surface	Transport Index
WHITE-I	= or < 0.5 mRem/hr.	NA
YELLOW-II	>0.5 mRem/hr. to = or < 50.0 mRem/hr.	= or < 1.0
YELLOW-III	>50.0 mRem/hr.	= or < 10.0

Fig 6.1 Various Label Dose Rates and Transport Indexes

The gauge instruction manual will include a radiation profile drawing showing dose rate measurements on the surface and at one meter. The Model MC-3 Elite fits the RADIOACTIVE YELLOW-II category.

RADIOACTIVE YELLOW-II labels must be placed on two opposite surfaces. The source type, source activity, and Transport Index entered should agree with the manufacturer's published data.



Fig 6.2 Yellow II Label

The Transport Index is an indicator to the vehicle operator the degree of control required. It is actually the maximum dose rate in mRem/hr. at one meter from the package. Since it is intended to be used by non-technical personnel, it is expressed as a dimensionless number rounded up to the nearest 1/10th. For multiple package shipments the driver limits the vehicle total TI to 50. Package(s) with a TI of 1.0 or less should not be closer to passengers than one foot. The TI for MC-3 Elite is 0.4.

Marking

The package must be marked with the following:

Shipping Name

RQ, Radioactive Material, Special Form, Type A Package,
UN3332

Package Type

7A TYPE A (in ½" characters)

Country of Origin
(International shipments)

USA

InstroTek combines the above information on one label.

Shipping Papers

The shipment must be accompanied by shipping papers which include:

Name of Shipper

RQ, Description

Contents and activity in Becquerel (in parentheses)

Label Category

Transport Index

Package Type

Certification/Signature:

This is not required for a private carrier if the shipment is not to be transferred to another party. It is easiest to include it, just in case.

Emergency Contact:

The shipper must provide the telephone number which must be monitored at all times the shipment is in transit and answerable by a person knowledgeable of the hazardous material being shipped and has comprehensive emergency response information, or has immediate access to a person with such knowledge. For normal daytime work, this can be the organization's phone number with instructions to notify the RSO. When returning a gauge from service or calibration, service centers will normally supply a 24 hour number.

Emergency Response

In addition to emergency response notification to the local Public Health Agency for an accident involving radioactive material, the National Response Number must be notified within 24 hours in the event of a transportation accident involving the release of radioactive material, the death or hospitalization of personnel, or property damage in excess of \$50,000.

National Emergency Number: 800-424-8802

InstroTek Accident Emergency Number: 800-535-5053

Preparation for Transport

1. **Inspection** - The gauge and package should be checked prior to each shipment. This should include:
 - The gauge handle is in the shielded position and the trigger is securely locked,
 - Confirmation that the shutter block is fully closed by either a visual inspection or radiation survey,
 - The gauge is placed properly in the package and that the package contains only those items which are required to be present,
 - The integrity of the package, case, hinge and hasps are in accordance with the package certificate,
 - All required labels and hazard markings are installed, legible and confirmed as correct,
 - That the package is locked or sealed in such a way that, while intact, will provide evidence that the package has not been opened.

2. **Bracing** - The package should be braced in the vehicle to prevent movement during transportation or a reasonable accident. This can be accomplished by brackets, chain, wire rope, or cord.
3. **Safety** - The package should not be in the passenger compartment. The preferred locations are the rear of a pickup, rear of a van, or trunk of a sedan.
4. **Secured** - The package should be chained—or wire roped—and locked to the bed of a pickup, locked in the freight area of a van, or locked in the trunk of a sedan to prevent theft. Two separate levels of security must be used to secure the gauge during transport and any time the gauge is not under continuous surveillance.
5. **Driving** - The technician should drive in a friendly, low-profile manner; for example, minimum lane changes. And park in the outer area of a public parking lot.
6. **Shipping Papers** - The driver should have within view and within reach (normally on the seat adjacent to the driver) the shipping paper, and the emergency response information sheet. To satisfy HAZMAT and other regulatory requirements it is recommended that each gauge have a documentation package as follows:
 - Bill of Lading
 - Emergency Response Sheet
 - Leak Test Certificate
 - Manual of operations
7. **Miscellaneous** - YELLOW-II does not require placarding the vehicle. Transporting the MC-3 Elite model does not require placarding the vehicle.

Commercial Shipments

The previously defined requirements for private carriage transportation apply with the following changes/additions:

1. **Label Consignor/consignee:**
An address label must be on the package.
2. **Lock or Seal:**
The package must incorporate a seal that if broken will show improper entry

Additional requirements depend upon the mode of commercial transportation; truck, air-domestic, and air-international.

Truck Freight

Shipping Paper:

The shipping paper will be a Bill of Lading supplied by the carrier and properly filled out by the shipper and emergency response form. If more than the gauge will be shipped, the hazardous material must be listed first. The pre-printed Bill of Lading includes the certification. A sample Bill of Lading and emergency response is in the Appendix.

Driver:

The driver may keep the shipping papers and emergency response in a pocket on the driver's door, on the passenger's seat, but not with the hazardous material.

Air Transport, Domestic

In the USA, shipment of the radioactive material in the gauge is not allowed on passenger carrying aircraft. This is not a problem since Federal Express, a cargo only airline, can transport the gauge anywhere in the USA overnight, if requested. While it is a domestic shipment, Federal Express has opted to follow the requirements of the International Air Transport Association (IATA) rather than 49CFR. This requires some changes and additional information.

Shipping Paper:

Federal Express has a special combination document that is both an Air Bill and a Declaration of Dangerous Goods Document. The DG document has specific places for the shipping information. It includes certification.

The words "Cargo Aircraft Only" must appear on the Air Bill.

The source activity must be stated in units of Bq, instead of, or in addition to the units of mCi on the DG document. Normally the prefix Giga (G) ($\times 1.0\text{e}9$) is used.

10 mCi (0.37 GBq)

50 mCi (1.85 GBq)

The size of the package in mm or meters must be stated on the DG document

Label:

The source activity must be stated in units of Bq, instead of, or in addition to the units of mCi on the RADIOACTIVE YELLOW-II labels.

A CARGO AIRCRAFT ONLY Label must be installed within 6" of each of the two RADIOACTIVE YELLOW-II labels.

Note: Pay attention to details of completing the form. Any minor error, like leaving the title off of the signer will be cause for rejection of the shipment. The carrier is not allowed to make corrections.

Air Transport, International

International air shipment of radioactive material is under IATA requirements. Most countries outside the USA will allow portable moisture/density gauges to be carried on passenger planes. However any international air shipments into or out of the USA must enter or exit the USA on a cargo only aircraft.

Shipping Paper:

The shipping paper will be an Air Bill supplied by the carrier and properly filled out by the shipper. The pre-printed Air Bill includes the certification. A normal practice is for the shipper to supply a Letter of Instruction, which includes the required export declaration, to a Forwarder, who in turn completes the Air Bill.

The words "Cargo Aircraft Only" must appear on the Air Bill. Besides the Air Bill, a Shipper's declaration of Dangerous Goods must accompany the shipment. This form is obtainable from the Air Carrier. It has a red "candy stripped border". Two copies are

required. It is best to supply additional copies if more than one carrier is involved in the routing. A sample is in the Appendix.

The source activity must be stated in units of Bq on the DG document.

The size of the package in mm or meters must be stated on the DG document. The DG document must cite the number of and Certificate of Competent Authority that was obtained from the appropriate government agency prior to the first export shipment of the type of sources in the gauge. In the USA it is obtained from the DOT. This document will generally be supplied by the gauge manufacturer, which obtained them from the source manufacture. These documents expire. Current copies should be obtained as appropriate. Some carriers require that copies of the cited Certificated be attached to the DG document. Certificates of Competent Authority on file may be used to satisfy the Special Form certification required to be on file for at least one year after the latest shipment.

Label:

The source activity must be stated in units of Bq on the RADIOACTIVE YELLOW-II labels.

A CARGO AIRCRAFT ONLY Label must be installed within 6" of each of the two RADIOACTIVE YELLOW-II labels.

7. Gauge Theory

This chapter covers the theory of operation for nuclear moisture density gauges.

Gamma and neutron radiation and their interaction with matter is a complex topic and difficult to cover in sufficient details in this manual. The discussion below will be limited to the engineering application of these radioisotope sources and their operations in the field.

Density Measurement

Density measurement in the gauge is accomplished by using a Cesium-137 (Cs-137) radioactive isotope and two Geiger Mueller (GM) detectors. Density measurements are usually accomplished in two different modes, backscatter (BS) and direct transmission. In the backscatter mode the source and the detector are in the same plane. In direct transmission, a hole is formed in the material and the source rod is inserted at a desired depth, between 2 and 12 inches (50 to 300 mm).

Cs-137 has a maximum energy of 0.662 Mev. Photons from the source penetrate the test material and are scattered back to the GM detector or absorbed by the material by Compton scattering and photoelectric absorption. In the density range of interest, the number of photons detected by the GM tubes is inversely proportional to the material density. For example, a given gauge at a density of 110 PCF (1760 kg/m³) will show 1500 counts; whereas, the same gauge will show a count of 700 at a density of 160 PCF (2560 kg/m³); therefore, the higher the counts, the lower the density.

The final stage of the gauge manufacturing process is the calibration. The density calibration method used by most manufacturers utilizes an exponential equation that models the relationship between the known densities and the counts. InstroTek uses the following equation.

$$CR = A \exp\left(-\frac{WD}{B}\right) + C$$

Where A, B and C are gauge parameters, CR is the count ratio and WD is the material density. The A, B and C values are commonly known as calibration constants. In the field when a count is collected on the test material, the resulting wet density (WD) displayed on the screen is calculated by:

$$WD = B \ln\left(\frac{A}{CR - C}\right)$$

Count ratio (CR) in the above equation is calculated by the ratio of counts to reference standard counts. Test Count (DC) is divided by Standard Count (DS).

$$CR = \frac{DC}{DS}$$

Cs-137 has a half-life of 30 years, 2.2 % reduction in intensity per year. The count ratio is used in this case to correct for natural decay of the source. For this reason it is very critical that users obtain an accurate reference standard count on a daily basis. This will ensure that any decay in the counts is canceled by the decay in the reference standard count. For example, six months after calibration, the Cs-137 source will decay 1.1% (1.1% reduction in counts). The 1.1% change will be reflected in the test counts and the reference standard count. Ratio of

these two counts will cancel the 1.1% effect on the counts and will in effect normalize the counts, regardless of the date of testing after calibration. Not using a count ratio will result in erroneous readings, if source decay is not accounted for.

Gauge software uses the gamma count taken at the test site and the standard count to automatically calculate and display wet density (WD) for the material.

Moisture Measurement

Moisture measurement in the gauge is accomplished by using an Americium-241: Beryllium (Am-241:Be) source, which emits fast neutrons, and a single Helium 3 (He-3) tube. Neutron measurements are always accomplished in the backscatter mode. Both the Am-241:Be and the He-3 tube are fixed inside the gauge base.

The average energy released by the Am-241:Be source is 4.5 Mev, with a spectrum energy ranging from 0 to 10 Mev. In the moisture measurement process, fast neutrons from the source interact with the hydrogen nucleus present in water and thermalize (slow down). The thermal or slow neutrons are then counted by the He-3 tube. Increase in water content results in a proportional increase in thermal neutron counts detected by the He-3 tube.

There are two assumptions made in the measurement of moisture by neutron method. First is that any interaction between the source and material is due to interaction with hydrogen in the form of water. Reviewing the composition of normal soils in the literature, the probability is very strong that any thermalization in soils is due to interaction with hydrogen in water. Second, that there are no elements that absorb neutrons. However, in construction type soils, boron in some

soils, chlorine in coastal soils, and iron oxide in deposits can be encountered in sufficient concentration to affect the readings. Gauge software contains offset features so that gauge readings can be corrected for these influences in the field.

Depth of Measurement

In density backscatter mode, the depth of measurement is independent of the density of the material. In backscatter mode 85% of the density reading is from the top 2.5 inches (64 mm) of the material and the remaining 15% is from the top 2.5 to 4 inches (64 to 100 mm) of the material.

Moisture measurement depth depends on the gauge geometry and moisture content of the material. The measurement of moisture is heavily weighted by the material closest to the gauge. In general a gauge with a range in moisture measurement of 0-40 PCF (0 to 640 kg/m³); the measurement depth is approximately 9 inches (230 mm) for soils containing 10 PCF (160 kg/m³) of moisture.

Calibration

Density Calibration - Calibration of density in the gauge is achieved by using blocks of known density. The objective of the calibration is to calculate the constants, A, B and C that are used in the density equation. Once these constants are determined, the gauge can be used in the field to calculate wet density.

$$CR = A \exp\left(-\frac{WD}{B}\right) + C$$

Since the above density equation used in the gauge contains three constants, it is necessary to use three known density blocks at the factory to provide an original calibration. There are many different methods of calibrating the gauge by assuming certain criteria or by using historical data. However, the bases of all these methods depend on having a minimum of three different counts for three different known density blocks.

Moisture Calibration - Gauge moisture calibration is performed by utilizing at least two blocks of known hydrogen density covering a range of moisture in the construction materials. The two blocks routinely used for moisture calibration are magnesium (0 lb./ft³, 0 kg/m³) and a combination block of magnesium and polyethylene (~ 35 lb./ft³, ~560 kg/m³). The gauge standard count and the counts on these blocks are used in a linear equation such as the one below to calculate the parameters E (intercept) and F (slope).

$$M = A * MCR - B$$

MCR is the moisture count ratio, which is the ratio of the measured moisture count and the daily moisture reference standard count. The daily reference standard count is performed on a high-density polyethylene block provided with each gauge. M is the moisture content of the material in PCF or kg/m³. The A and B parameters are placed in the gauge memory and are used in the field with the count ratio obtained on the test material to calculate the moisture content from the above equation.

Gauge Errors

Density - There are three error parameters inherent in all gauges manufactured: Nuclear Precision (P), Surface Roughness (SR), and Composition Error (CE).

Precision or repeatability of the gauge is defined as the variation in repetitive density reading on the same test spot for a given counting time. Precision is calculated based on the equation ($P = \sqrt{\text{Count}} / \text{Slope}$) which depends on the number of counts collected during a given period and the volume of the test material measured by a specific gauge at a given depth. Precision for a typical gauge for a one minute reading at the time of manufacture is approximately ± 0.5 PCF (8 kg/m³) at backscatter and ± 0.25 PCF (4 kg/m³) at 6" direct transmission depth. The reduction in precision over the life of the gauge (approximately 20 years) is insignificant.

Surface Roughness error is caused by streaming of photons from the source to the detectors in the air space immediately under the gauge. Surface roughness error at BS depth is much higher than direct transmission. Surface error is usually calculated by taking a reading with the gauge directly on limestone block and repeating the reading on the same block with 0.05" (1.3 mm) gap under the gauge (100% air voids). The difference between the flush and raised reading is a measure of the error expected from the gauge on rough surfaces, such as open graded or base coarse asphalt. Filling the surface with Portland cement or fine cement powder helps reduce this error, when measurements are taken on rough materials.

Composition Error - is caused by the effect of material characteristics on the gauge measured density. Since attenuation of photons is effected by chemical composition of the material, density measurements can be effected

significantly by soils with compositions significantly different than the references with which the gauge is calibrated. This error indicates the amount of error you will have in your measurements when going from one soil composition extreme to another. Composition error is determined by measuring limestone and granite standards with known densities. Standards of limestone and granite that are homogenous are available which have compositions that bracket the composition of most soils. Composition error for nuclear gauges is calculated by the following equation.

$$CE = \frac{[(\text{Lime (Gauge)} - \text{Lime (Actual)}) - (\text{Granite (Actual)} - \text{Granite (Gauge)})]}{2}$$

Lime (Gauge) and Granite (Gauge) are density of limestone and granite standards measured by the gauge after calibration. Lime (Actual) and Granite (Actual) are actual density values of limestone and granite. This error indicates the amount of error you will have in your measurement when going from one soil composition extreme to the other.

Composition error in most gauges can be minimized by appropriate filtering of the detection system and /or adjustment of the source to detector distance. Even though this error can be minimized, any adjustment to reduce this error can cause an increase in surface error and reduction in gauge repeatability. During design, it is extremely critical that the gauge geometry is optimized to reduce all the above errors to an acceptable limit.

Moisture – The moisture source has a half-life of 430 years and the reduction in moisture precision is insignificant over the life of the gauge.

As mentioned in the previous sections of this manual, there are two assumptions made in the measurement of moisture by neutron method. First is that any interaction between the source and material is due to interaction with hydrogen in the form of water. Second, that there are no elements that absorb neutrons. However, in construction type soils, boron in some soils, chlorine in coastal soils, and iron oxide in deposits can be encountered in sufficient concentration to affect the readings. Also, variation in bound hydrogen in clay soils can cause significant errors in gauge moisture readings and have to be corrected for under the offset functions in the MENU.

Gauge software contains offset features to account for some of these errors in the reading. Refer to the Menu functions for more details on how to correct your gauge readings using offset functions.

8. Routine Maintenance and Troubleshooting

This chapter covers routine maintenance items such as leak test procedure, routine maintenance of gauge components, and troubleshooting hints.

Leak Test Procedure

Leak test is required by your license and shall be performed at least once every twelve months (1 year), unless indicated differently by your license. To conduct a leak test on MC-3 Elite, follow the below procedure:

1. Place the gauge in safe position.
2. Remove the four screws from the front panel and lift the panel.
3. Locate the radiation label in the bottom of the gauge.
4. Using InstroTek Leak Test Kit, moisten one swab from part number 520.7200,
5. Wipe the radiation label with the swab.
6. Replace the front panel and tilt the gauge on its side.
7. Use the swab and wipe around the source rod opening under the gauge.
8. Place the swab in the plastic bag included with kit.
9. Record the gauge and source information on the form included with kit.
10. Package the swab and the information form and mail to InstroTek for analysis.
11. Tighten the four screws on the front panel and store the gauge.

Routine Maintenance

Radiation sources

The MC-3 Elite contains two radioactive sources. The sources require no maintenance. The small Americium-241:Beryllium source is in the center of a lead cup. The source is inside a lead cup which screws into the shielded area in the center of the gauge base. **Do not attempt to remove this source.** The Cesium-137 is inside the end of the source rod which is inside the guide tube. The source is fixed inside the tip of the source rod. In the safe position (source rod handle at the top of the guide tube marked "**safe**") the Cs-137 source is surrounded by lead and tungsten shielding. **Do not attempt to remove this source from the source rod.**

Bottom Plate

Maintenance in the bottom plate area of the gauge may be required if the following problems are encountered while using the gauge. Difficulty in lowering or raising the source rod when pulling the handle up or down, and/or unusual density counts. These are generally an indication that soil or other material has migrated into the bottom of the gauge and it needs to be cleaned and fresh grease added.

Important: InstroTek recommends use of only MagnaLube G as a greasing agent in this gauge. MagnaLube has Teflon filler, which provides superior and longer lasting performance in the environment these gauges are typically used.

MagnaLube G is a trademark of SaundersEnterprises, Inc.
Teflon is a trademark of DuPont Company.

Procedure

1. With the source rod in the "SAFE" position, place the gauge on its side with the bottom plate to your right or left. (This positioning will prevent unnecessary radiation exposure to the operator.)
2. Examine the bottom plate. Clean the screw heads if necessary to make removal easier and to prevent the screw heads from stripping.
3. Use a Phillips screwdriver to remove the bottom plate. It is normal to see evidence of wear, however if deep grooves are present where the sliding block slides, it may indicate that the plate needs replacement. There should be a scraper ring in the bottom plate hole where the source rod extends; if the ring is worn or missing call InstroTek for a replacement.
4. If a large amount of dirt has accumulated in the cavity above the bottom plate, the scraper ring has become worn and should be replaced. Replace the scraper ring by removing the retaining ring with a small screwdriver. It is recommended that the scraper ring be changed at least once a year or more often depending on the use. The scraper ring can be pushed out. Clean the entire plate of any debris and install a new scraper ring and retaining ring. Add a thin layer of grease where the sliding block slides.
5. To remove the sliding tungsten shield, use a screwdriver to pull the shield out by the spring.

Remember to stand to the side with the source rod in the safe position. Use a screwdriver and rag to remove debris from the sliding block cavity.

Caution: Do not use your hand to clean this area.

Clean the sliding block and spring, add a thin layer of grease to the sides, top, bottom, and angle of the block; reinstall. Make sure the end of the spring is centered in the spring holding support so the sliding block moves straight in and out.

Source Rod Bearings

1. The source rod bearings will need periodic lubrication with MagnaLube. Indications of this are difficulty in moving the rod up and down or binding of the rod. Add MagnaLube to the swab and swab the source rod at the point of entry into the gauge.

Cleaning

Most of the gauge cleaning should be done with a mild cleaner such as 409 or a citrus based cleaner like GooGone. We do not recommend using fuels (gasoline or diesel) or oils to clean the gauge as these chemicals can damage plastic, rubber, and synthetic materials. If the aluminum gauge bottom becomes coated with asphalt, WD-40 or GooGone will remove the asphalt. Keep the liquefied asphalt away from the plastic surfaces and gaskets. Be sure to wipe off residue before putting the gauge back in use.

Handle Assembly Inspection

Inspect the handle assembly monthly for wear.

1. Set Handle in BS position
2. Loosen 5/32" in Allen head hex screw on side of guide tube ONLY until handle is free. Do not remove screw.
3. Pull Handle away from guide tube.
4. Check beveled front edge of handle latch for excessive wear.

Handle Assembly Inspection

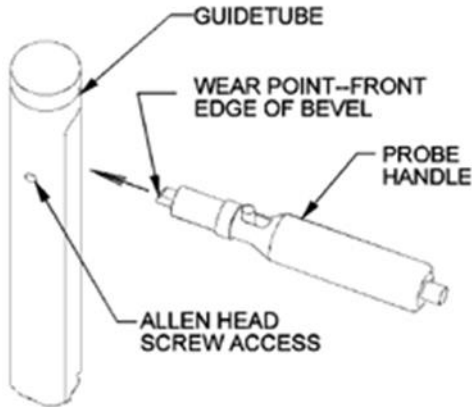

Fig. 8.1

5. Check notches inside guide tube for excessive wear.

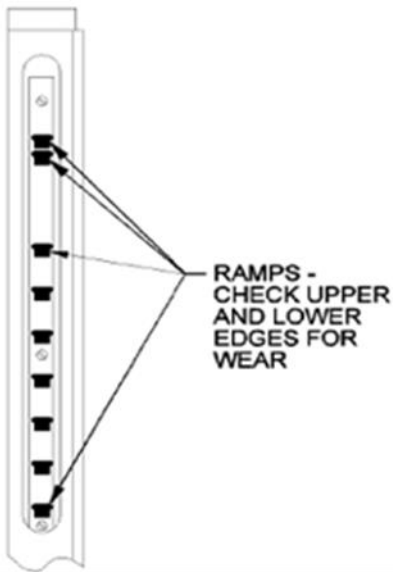

Fig 8.2

6. Reassemble handle to guide tube assembly and Tighten the Allen screw.

Note: If wear on the notches or latch appears to be excessive, contact your CPN-InstroTek service representative for assistance.

Troubleshooting

Symptom	Probable Cause
<i>Gauge does not power on</i>	<ol style="list-style-type: none">1. Dead batteries, recharge or change batteries2. Gauge inside is wet, dry the interior of the gauge3. Ribbon cable inside the gauge is defective or not connected4. Keypad is defective
<i>Density readings are incorrect</i>	<ol style="list-style-type: none">1. Check calibration constants2. Check standard count
<i>Counts are erratic</i>	<ol style="list-style-type: none">1. Circuit problem, contact InstroTek

9. Specifications and Appendices

Specifications:

National and International Standards	ASTM D6938, D2950, D7013, D7759, C1040; AASHTO T310
Density Measurement Range	1120 to 2720 Kg/m ³ (70 to 170 lbs./ft ³)
Moisture Measurement Range	0 to 640 Kg/m ³ (0 to 40 lbs./ft ³)
Density Source	Cesium 137
Moisture Source	Americium 241: Beryllium
Density Source activity	0.37 GBq, 10 mCi
Moisture source activity	1.85 GBq, 50 mCi
Transport Index (TI)	0.4 mRem
BS Precision at 2000 Kg/m³	7.8 kg/m ³ (0.49 lbs./ft ³)
Direct Transmission Precision at 2000 Kg/m³	3.5 kg/m ³ (0.22 lbs./ft ³)
Moisture Precision at 240 Kg/m³	4.42 kg/m ³ (0.28 lbs./ft ³)
Composition Error BS	16 kg/m ³ (1.0 lbs./ft ³)
Composition Error Direct Transmission	13 kg/m ³ (0.8 lbs./ft ³)
Surface Error BS	48 kg/m ³ 3.0 lbs./ft ³)
Surface Error 150 mm (6") depth	16 kg/m ³ (1 lbs./ft ³)
Backlight Display and Keypad	Yes
Internal Temperature Monitoring	Yes
Shielding Materials	Lead, Tungsten, and Cadmium
Top Shell	UV stabilized plastic
Batteries	6 NiMH AA rechargeable and one 9v Alkaline backup battery
Base and tower	Aluminum
Source Rod	Stainless Steel
Guide Tube	Aluminum
Operating Temperature	

(ambient)	<i>-10° to 70° C (14° to 158° F)</i>
Maximum Surface Temperature	<i>170° C (338° F)</i>
Gauge Size	<i>67.8cm x 35.8cm x 24.8cm (26.7"x14.1" x 9.75")</i>
Weight	<i>13Kg (28.5 lbs.)</i>
Shipping Weight	<i>40 Kg (90 lbs.)</i>

Appendix 1: Sample Bill of Lading

Bill of Lading

Shipper:

**ABC Company, Inc.
1234 John Smith Rd
Raleigh, NC 27617**

**RQ, UN 3332, Radioactive Material, Special Form, NON FISSILE
OR FISSILE
EXCEPTED, 7**

Type "A" Package, Containing:

**Cs-137, 0.37 GBq (10 mCi)
Am-241:Be, 1.85 GBq (50 mCi)**

Radioactive Yellow II Label, TI=0.4

*******EMERGENCY CONTACT*******

1-800-535-5053

Shipper

(Signature)

Appendix 2: Emergency Response Information

Nuclear Gauge Emergency Response Information for Transportation

Reference DOT ERG 2016 pg 266-267 Guide 164, and 49CFR

Potential Hazard

1) Proper Shipping Name

- UN3332 Radioactive Material Type A Package, Special Form, 7, RQ

2) Health Hazards

- Radiation presents minimal risk to transport workers, emergency response personnel and the public during transportation accidents. Packaging durability increases as the potential hazard of radioactive content increases.
- Undamaged packages are safe; contents of damaged packages may cause external radiation exposure and much higher external exposure if contents (source capsules) are released.
- Contamination and internal radiation hazards are not expected, but not impossible.
- Packages (cartons, boxes, drums, articles, etc.) identified as "Type A" by marking on packages or by shipping papers contain non-life endangering amounts. Radioactive sources may be released if Type A packages are damaged in moderately severe accidents.
- Type B packages, and the rarely occurring Type C packages, (large and small, usually metal) contain the most hazardous amounts. They can be identified by package markings or by shipping papers. Life-threatening conditions may exist only if contents are released or package shielding fails. Because of design, evaluation, and testing of packages, life endangering

releases are not expected in accidents except those of utmost severity.

- Radioactive White-I labels indicate radiation levels outside single, isolated, undamaged packages are very low (less than 0.005 mSv/h (0.5 mRem/hr)).
- Radioactive Yellow-II and Yellow-III labeled packages have higher radiation levels. The transport index (TI) on the label identifies the maximum radiation level in mRem/h one meter from a single, isolated, undamaged package.
- Radiation from the package contents, usually in durable metal capsules, can be detected by most radiation instruments.
- Water from cargo fire control is not expected to cause pollution.

3) Fire or Explosion

- Packaging can burn completely without risk of content loss from sealed source capsule.
- Radioactivity does not change flammability or other properties of materials.
- Radioactive source capsules and Type B packages are designed and evaluated to withstand total engulfment in flames at temperatures of 800°C (1475°F) for a period of 30 minutes.

Public Safety

- **CALL EMERGENCY RESPONSE Telephone number on Shipping Paper first. If Shipping Paper is not available or there is no answer, refer to the appropriate telephone number listed on the inside back cover of the DOT Emergency Response Guidebook.**

**EMERGENCY RESPONSE PHONE #: 1-800-535-5053 (US & Canada)
1-352-323-3500**

- **Priorities for rescue, life-saving, first aid, fire control and other hazards are higher than the priority for measuring radiation levels.**
- Radiation Authority must be notified of accident conditions. Radiation Authority is usually responsible for decisions about radiological consequences and closure of emergencies.
- As an immediate precautionary measure, isolate spill or leak area for at least 25 meters (75 feet) in all directions.
- Stay upwind, uphill and/or upstream.
- Keep unauthorized personnel away.
- Delay final cleanup until instructions or advice is received from Radiation Authority.

4) Protective Clothing

- Positive pressure self-contained breathing apparatus (SCBA) and structural firefighters' protective clothing will provide adequate protection against internal radiation exposure, but not external radiation exposure.

5) Evacuation

Large Spill

- Consider initial downwind evacuation for at least 100 meters (330 feet)

Fire

- When a large quantity of this material is involved in a major fire, consider an initial evacuation distance of 300 meters (1000 feet) in all directions.

6) Fire

- Presence of radioactive material will not influence the fire control processes and should not influence selection of technique.
- Move containers from fire area if you can do it without risk.

- Do not move damaged packages; move undamaged packages out of fire zone.
- Small Fires:
 - Dry chemical, CO₂ water spray or regular foam.
- Large Fires:
 - Water spray, fog (flooding amounts)

7) Spill or Leak

- Do not touch damaged packages or spilled material.
- Damp surfaces on undamaged or slightly damaged packages are seldom an indication of packaging failure. Contents are seldom liquid. Content is usually a metal capsule, easily seen if released from package.
- If source is identified as being out of package, **DO NOT TOUCH**. Stay away and await advice from Radiation Authority.

8) First Aid

- Ensure that medical personnel are aware of the material(s) involved, take precautions to protect themselves.
- Call 911 or emergency medical service.
- Medical problems take priority over radiological concerns.
- Use first aid treatment according to the nature of the injury.
- Do not delay care and transport of a seriously injured person.
- Persons exposed to special form sources are not likely to be contaminated with radioactive material.
- Give artificial respiration if victim is not breathing.
- Administer oxygen if breathing is difficult.
- Injured persons contaminated by contact with released material are not a serious hazard to health care personnel, equipment or facilities.

Appendix 3: Model MC-3 Elite Radiation Profile

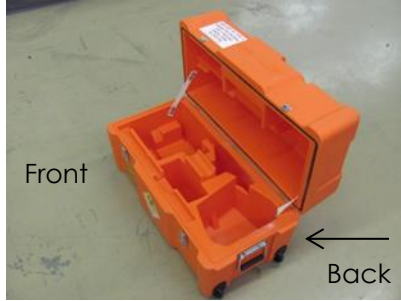

Fig A3.3 Open Case Radiation Profile

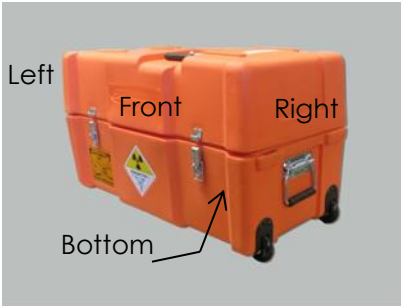

Fig A3.1 Closed Case Radiation Profile



Fig A3.2 Gauge Radiation Profile

Readings in mREM/HR

Readings in MREM/HR @ "X" Meters		Front		Back		L Side		R Side		Top		Bottom		Handle	
		Gamma	Neutron	Gamma	Neutron	Gamma	Neutron	Gamma	Neutron	Gamma	Neutron	Gamma	Neutron	Gamma	Neutron
G a u g e	.05 M	5.0	2.0	6.0	2.0	4.0	1.6	5.5	1.4	2.8	2.0	12.0	4.0	0.2	0.8
	.3 M	0.5	0.8	0.4	0.6	0.1	0.2	1.2	0.1	1.2	0.3	4.0	1.0		
	1.0 M	0.1	0.0	0.1	0.0	0.0	0.0	0.1	0.0	0.1	0.0	0.1	0.2		
C a s e	.05 M	2.2	0.8	1.5	1.2	0.3	0.2	4.0	2.0	3.0	0.4	3.0	1.2		
	.3 M	0.4	0.3	0.4	0.7	0.1	0.0	0.5	0.6	1.0	0.2	1.1	0.3		
	1.0 M	0.1	0.1	0.1	0.0	0.0	0.0	0.1	0.1	0.1	0.1	0.1	0.01		

Notes:

- 1- Gamma Measurements made with a Victoreen Model 492 Ionization chamber, S/N 3695.
- 2- Neutron Measurements made with a Ludlum Model 12-4 neutron meter, S/N 237866, calibrated.
- 3- Dose rates are for 10 (+/- 10%) mCi Cs-137 gamma source and 40 (+/- 10%) mCi Am241:Be neutron source.

10. Index

#

49CFR..... 65-66, 74, 95

A

AASHTO 92

Accessories..... 3

ALARA..... 55

ALPHA Particles..... 50

Am-241/Be52, 66, 79

ASTM 92

Atom47-48

Auto Scroll.....25, 29, 45

Auto-Depth 25

Auto-Depth Calibration 25

Average Standard Mode 26

B

Base and tower 92

Batteries4, 7, 30, 91

Battery Low..... 4

Battery Voltage25, 30

Beta Particles51-52

Bill of Lading 94

Bottom Plate 86

C

Calibration Constants..... 26, 31, 44-45, 78
 Cargo Aircraft Only..... 74-76
 Cesium-137 50-52, 58, 77, 86
 Charger 4, 7, 30
 Cleaning.....63, 88
 Composition Error 82-83, 92
 Count Ratio.....21, 37, 52, 78

D

Daily Standard Count10, 35
 Density 10, 13, 27, 77
 Density Calibration..... 78-80
 Density Error82
 Density Measurement Range.....92
 Density Offset27
 Density Source.....10, 92
 Depth of Measurement.....37, 80
 DG Document..... 74-76
 Display Contrast.....45
 Distance57
 Dosimetry59
 Drift Test 25, 31-32
 Drill Rod..... 3, 17-18
 Dry Density15, 21

E

Earth's Crust.....	49
Elements.....	47-48, 79, 84
Emergency Number	71
Emergency Response	70-72, 95
Extraction Tool	3, 17

G

Gamma Radiation.....	50-53
Gamma Rays	50-53
Gauge Disposal.....	64
Gauge Errors	82
Gauge Shipping Weight	93
Gauge Size	93
Gauge Theory.....	77
Gauge Transfer.....	62
Gauge Weight.....	93
GM Tube	6, 77

H

Half-Life	52
HAZMAT.....	65, 72
He-3 Tube.....	6, 79

I

IATA.....	74-75
InstroTek Accident Emergency Number	71
Internal Temperature Monitoring	92

International Air Transport Association See IATA

Isotopes 48-50

J

J-45 45

K

Keypad 6, 11, 25, 29, 34-35, 91

L

LCD 25

LCD Backlight 25, 29-30

Leak Test Kit 59, 85

Leak Test Procedure 85

Leak Testing 59

License 58

M

MagnaLube G 86

Maintenance 63, 86

Marshall 13

Maximum Surface Temperature 93

Memory Clear 31

Menu Functions 25

Moisture 62

Moisture Activity 62

Moisture Calibration 80

Moisture Count Ratio 20

Moisture Error 27, 83

Moisture Measurement Range 79
Moisture Offset 27
Moisture Source 84, 92
mRem 54-55, 100

N

National Emergency Number..... 71
Natural Radiation 54-55
Neutron Particles 51
Neutron Radiation..... 51, 57, 77
Nomograph..... 26, 41
Notice to Employees 61

O

Offset 26-27
Operating Temperature 92

P

Personal Monitoring 59
Precision 9, 82
Proctor 13-14, 21

Q

QF 53
Quality Factor 53

R

RAD 53
Radiation Profile 68, 99, 105
Radiation Safety 53, 60-61

Radiation Safety Officer.....See RS

Radiation Theory.....47

Radioactive4, 10, 50-54

Radioactivity.....50-52

Recall25-26

Reciprocity63

Regulations58, 62, 65

Rem53

Reset Button.....45

Ribbon Cable91

Roentgen53

Routine Maintenance

Bottom Plate86

Cleaning88

Leak Test59, 85

Radiation Sources86

Source Rod Bearings.....88

RS-232.....45

RSO59, 61

S

Safety Plan61

Scraper Plate3, 17

Self-Test6-7

Serial Number26, 35

Service/Maintenance.....63

Setting Depth	10-12
Setting Target/Laboratory Density Values...	13
Setting Test Time	9
Setting Units	8
Shielding.....	57
Shielding Materials	92
Shipping Case.....	3, 107, 110

Site Preparation

Asphalt	19
Soil, Aggregates, or Granular Materials	17
SmartCharge	5
Source Rod	88, 92
Source Rod Bearings	88
Special Calibration	26, 36
Specifications.....	39, 92
Standard Block	3, 6, 7, 11, 28
Standard Count.....	10-11, 12-13, 25, 28
Stat Test	25, 33
Surface Roughness Error	82

T

Temporary Storage	62
Time.....	35, 56
Top Shell	92
Training	60, 65
Transport Index	67-68, 70, 92

Transportation65

 Air Transport, Domestic..... 74

 Air Transport, International..... 75

 Commercial Shipments..... 73

 Emergency Response.....70-73

 General Awareness 65

 Labeling 67

 Marking 68, 95

 Packaging 67, 96

 Preparation for Transport 71

 RADIOACTIVE YELLOW-II 68, 75-76, 96

 Reportable Quantity..... 66

 Shipping Name 65-66, 69, 95

 Shipping Papers.....69, 72, 95

 Specific Functions 65

 Transport Index 67-68, 70, 92

 Truck Freight 73

Trench Offset 28-29

Troubleshooting85, 91

U

Units 8, 26, 34, 44, 75-76

V

Void-less Density 16

W

Wet Density 15, 21, 27, 42, 78-79

Y

YELLOW-II 67-68, 75-76

11. Warranty

InstroTek, Inc. extends a 2-year limited warranty on the Model MC3 Elite™ to the original purchaser of this equipment. This warranty covers defects in material, workmanship, and operation under the conditions of normal use and proper maintenance. This warranty includes all components except for the normal wear components including all accessories, shipping case, seals, batteries, scraper ring, and reference standard block.

InstroTek will replace, free of charge, any part found to be defective within the warranty period.

This warranty is void if inspection shows evidence of abuse, misuse, or unauthorized repair.

This warranty covers replacement of defective materials and workmanship only. It does not cover shipping charges, duties, or taxes in the transport to and from the factory or authorized service center.

InstroTek's liability is in all cases limited to the replacement price of its products. InstroTek shall not be liable for any other damages, whether consequential, indirect, or incidental arising from use of its product.

If return of the product is necessary, please include return shipping directions, contact name, phone & fax number and a description of the action needed.

Call InstroTek, Inc. for shipping details at (919) 875-8371.

Contact Information



Innovators in Instrumentation Technology

www.InstroTek.com | (919) 875-8371 | sales@InstroTek.com

Research Triangle Park, NC | Austin, TX | Bensalem, PA | Grand Rapids, MI | Denver, CO | Las Vegas, NV | Concord, CA



Contact us for top quality, best value and superior service!

email: sales@instrotek.com + visit: InströTek.com

CALL A LOCATION NEAR YOU:

Headquarters: **Research Triangle Park, NC** phone: **919.875.8371**

Bensalem, PA phone: **215.645.1064** + **Grand Rapids, MI** phone: **616.726.5850**

Denver, CO phone: **303.955.5740** + **Austin, TX** phone: **512.452.8848**

Las Vegas, NV phone: **702.270.3885** + **Concord, CA** phone: **925.363.9770**