



**InstronTek[®]
Inc.**

innovators in instrumentation technology

HWTPRO[™]

HAMBURG VERIFICATION & CALIBRATION DEVICE

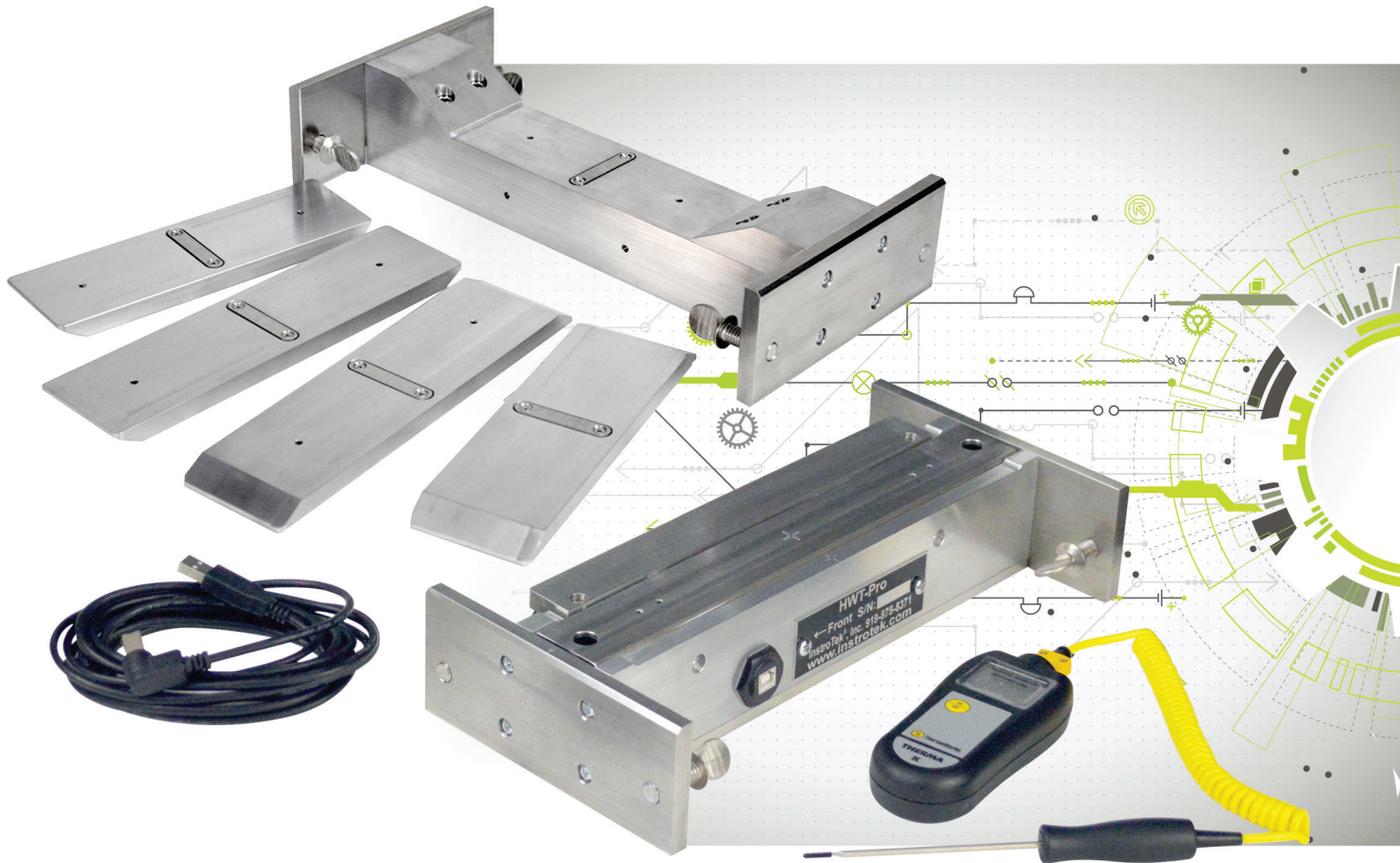

OPERATING MANUAL

www.InstronTek.com

Contents

Introduction	4
Configuring the HWT-Spec Software	6
Starting the Software	6
Connecting to the Load Sensor	6
Verification versus Calibration.....	8
SmarTracker	10
Installing the HWT-Pro in a SmarTracker.....	10
Verification Procedure	13
Load Verification	13
Waveform Verification	14
Displacement Verification	15
Temperature Verification.....	17
Calibration Procedure	18
Load Calibration	18
Displacement Calibration	18
Verification of Displacement Calibration	19
Verification of Calibration	19
PMW/Troxler Units.....	20
Installing the HWT-Pro in a PMW/Troxler Wheel Tracker.....	20
Verification Procedure	24
Load Verification	24
Waveform Verification	26
Displacement Verification	27
Temperature Verification.....	29
Calibration Procedure	30
Load Calibration	30
Displacement Calibration	30

Verification of Results	31
Cox and Sons	32
Installing the HWT-Pro in a Cox and Sons Unit.....	32
Verification Procedure	36
Load Verification	36
Waveform Verification	38
Displacement Verification	39
Temperature Verification	40
Calibration Procedure	41
Load Calibration	41
Displacement Calibration	41
Verification of Results	42
Saving/Printing the Results.....	43
Reviewing data saved to an Excel sheet	44
Updating the Firmware in the HWT	44

Introduction

This manual provides instructions on how to use the HWT-Pro verification and calibration kit with different Hamburg wheel tracker (HWT) machines. General instructions to perform the verification or calibration are included in the software. Details on how to perform the verification or calibration with a given machine are available in this manual.

InstroTek's HWT-Pro makes it quick and easy to verify that your Hamburg wheel tracker meets the requirements of the AASHTO T 324 specification. The specification requires measuring the following parameters.

Force

- Static Weight Applied by Wheel – 703 ± 4.5 N (158 ± 1 lbs)

Wheel Movement

- Passes per Minute – 52 ± 2
- Distance from Center – 0 ± 12.5 mm (0 ± 0.5 inch)
- Speed at Center – 0.305 ± 0.02 m/s (1 ± 0.066 ft/s)
- Deviation from Sine Wave – ≤ 2.54 mm (0.1 inch) (recommended)

Rut Height

- Deviation of Displacement – ≤ 0.15 mm over 20 mm (0.006 inch over 0.79 inch)

Temperature

- Temperature – $\pm 1.0^\circ\text{C}$ (1.8°F)

To verify the items in the specification, calibrated equipment such as load cells and calibrated height blocks are required. Recommended changes to the AASHTO T 324 standard in NCHRP Web-Only Document 219 also require a device that can measure the real-time movement of the wheel to verify the deviation of the sine wave. The HWT-Pro equipment and HWT-Spec software, installed on a Windows-based controller, provide you the tools to verify your wheel tracker on a regular basis. The HWT-Spec steps you through the tests necessary to verify each specification one at a time. Then, you can review and print the results. If any modifications to calibrations or weights are necessary, the HWT-Pro is accurate enough that it can be used for calibrations. After any adjustments are made, they can be verified using the HWT-Pro.

The system consists of the following:

- HWT-Pro Load Sensor – A device with 2 load cells, amplifier, and USB interface to confirm the weight and wheel movement

-
- HWT-Pro Height Indicator – Calibrated height blocks to confirm the rut depth is measured correctly in-place
 - HWT-Spec – Software to interface with the HWT-Pro and print the relevant results.



HWT-Pro Load Sensor



HWT-Pro Height Indicator with
Spacer Plates

Verification Kit Components

- HWT-Pro Load Sensor
- HWT-Pro Height Indicator
 - 4 individual 10 mm Gauge Blocks (0.4 inch for English dimensions)
 - 1 individual 5 mm Gauge Block (0.2 inch for English dimensions)
 - 4 individual 10 mm Gauge Block placement slats
 - 1 individual 5 mm Gauge Block placement slat
 - 1 LVDT Support Stand
- HWT-Pro Displacement Calibrator
- HWT-Pro Calibration Report
- HWT-Pro NIST-Traceable Thermometer
- USB Cable
- Spacers for Molds of Different Manufacturer Machines
 - 4 Polyethylene centering blocks
 - 2 Polyethylene centering c-brackets
- 1 - Spacing bar (1/8" x 1/8" x 14")
- HWT-Pro Controller

Configuring the HWT-Spec Software

Starting the Software

1. Start the application by clicking the icon pinned to the taskbar or in the “START” menu at “All Programs -> HWT_Spec”.
2. A splash screen will appear while the application initializes. When the initialization has finished, the application will show “Connecting to the HWT-Pro” screen when it cannot automatically connection to the Load Sensor.

Connecting to the Load Sensor

The HWT-Pro controller has been set to automatically connect with the Load Sensor at the factory. If it does not connect, follow the steps below.

1. Connect the Load Sensor to the HWT-Spec Controller with a USB cable.
2. Determine the COM Port the Load Sensor utilizes.
 - a. Open the Device Manager.
 - i. Press the Start button.
 - ii. Type “Device Manager” in the search bar.
 - iii. Click on Device Manager.
 - b. Click on the arrow for “Ports (COM & LPT)”.
 - c. Find the COM port listed for “USB Serial Port”.

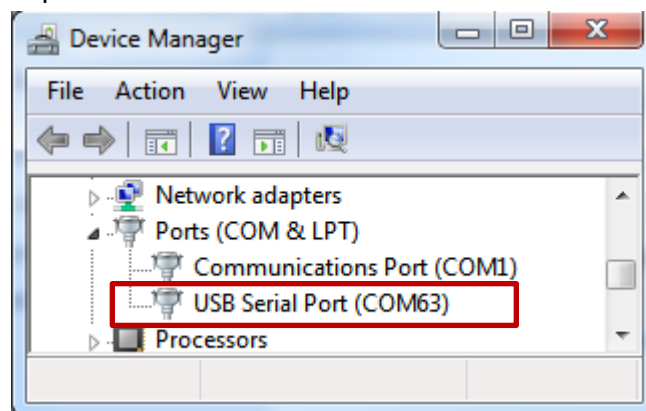

NOTE: In the figure above, the correct COM port is COM63.

3. Open the HWT-Spec software and click on “Communication” at the top-left of the application.



4. Select the appropriate COM port from the drop-down box.

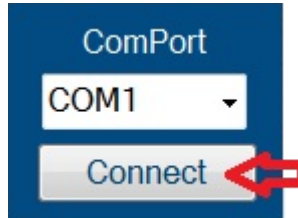

5. Press the "Connect" button to open the Serial Port.
 - a. If the serial port connects correctly, the software will display the current load on the Load Verification tab.
 - b. If the serial port does NOT connect, check that the USB cable is connected to the PC/Laptop and Load Sensor or try another port.

Verification versus Calibration

Before using the HWT-Pro, it is important to decide whether one will *verify* or *calibrate* the machine. *Verification* means checking whether the critical parameters discussed in the Introduction are satisfied. If certain parameters are outside the limits or fail, then the machine needs to be *calibrated* or adjusted to bring it back into specification. Therefore, the normal procedure is to verify the Wheel Tracker is working properly on a regularly basis, such as **monthly or quarterly**. If the machine passes, no additional work is necessary. If the machine fails, then it must be calibrated. The output of the two methods is different. Verification provides a report of the measurement with pass/fail values. Calibration provides expected and measured values to show where differences might be in weight or transducer displacement.

Verification includes: load, waveform, displacement (rut depth), and temperature verification

Calibration includes: load and temperature verification, and displacement calibration



SmarTracker

Installing the HWT-Pro in a SmarTracker

1. Prepare the Wheel Tracker.
 - a. Clean the tray. All asphalt binder and mixture should be removed before installing either the HWT-Pro Load Sensor or Height Indicator.
 - b. Clean the wheels of any residual asphalt according to the manufacturer's recommendations.
 - c. Remove the plastic molds used to hold the asphalt mix specimens for normal testing.
2. Drain any water from the Wheel Tracker.
3. Remove the Load Sensor or Height Indicator from the case. Also, remove the 4 rectangular plastic spacers for the SmarTracker, as shown in Figure 1.
4. Mark the centerline of the mold.
 - a. Place one of the specimen molds into the specimen tray. Make sure it is pushed all the way to one end of the specimen tray.
 - b. Place the 1/8 inch spacing bar against the other end of the mold towards the center of specimen tray. Mark the edge of the specimen tray. This is the center of the specimen tray.



5. Place the Load Sensor or Height Sensor in the specimen tray such that the arrow on the serial plate points toward the front of the machine (toward the user).
6. Insert the rectangular spacers into the specimen tray (Figure 1) to center the device. The letter **S** should point toward the center of the mold in the direction of the wheel travel.

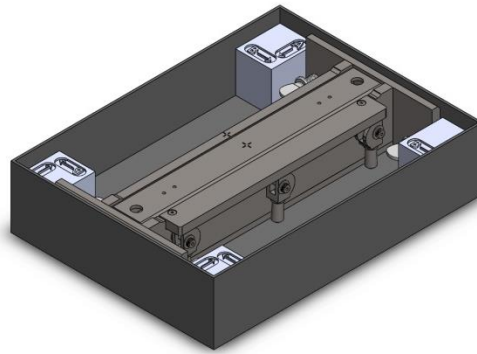
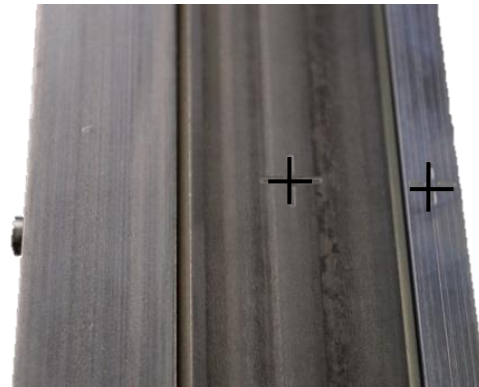
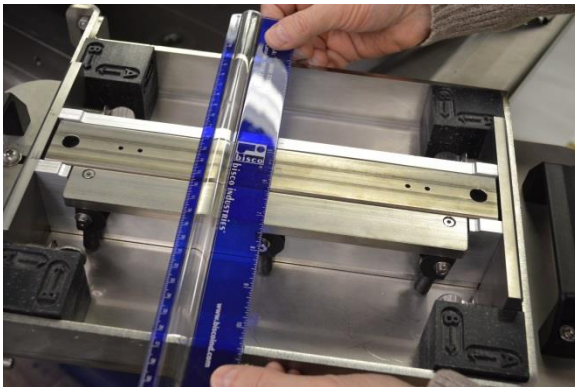
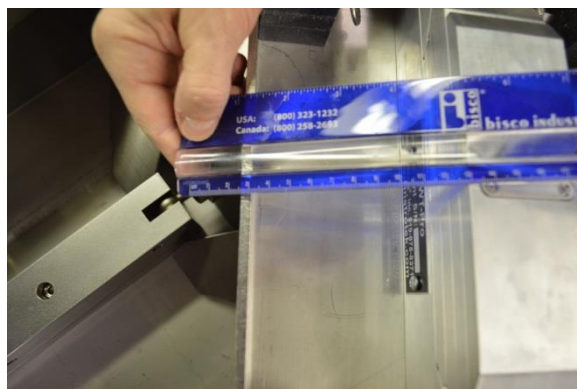
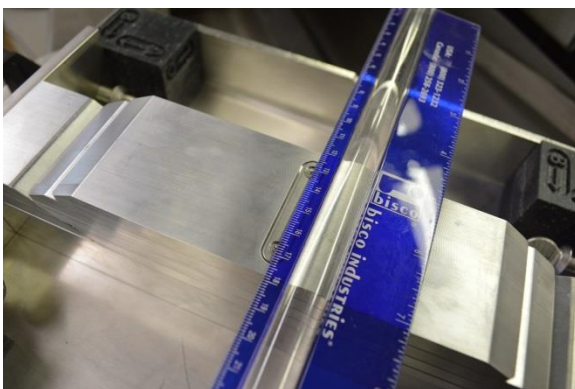

Figure 1. Placement of spacers and Load Sensor or Height Indicator in HWT specimen tray for the SmarTracker

7. Adjust the set screws in the metal bars at the end of the HWT-Pro device so that its center matches the centerline marks on the specimen tray. Use the 1/8" spacing bar or other straight edge to verify the alignment of the centers.
 - a. Load Sensor: Align the centerline marks with both "+" in the center of the Load Sensor using the spacing bar.



- b. Height Indicator: Align the center of the screw holes in the center bar with the center marks on the specimen tray.



-
8. Attach the supplied USB cable to the Load Sensor and HWT-Pro Controller.

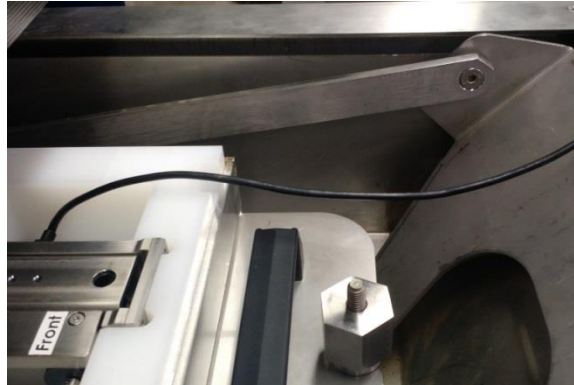

Warning! The HWT-Pro is not waterproof!

Make sure all the water has been drained before inserting the Load Sensor

9. Insert the Load Sensor or Height Indicator and specimen tray into the Wheel Tracker like it was a specimen with molds. Be sure to tighten the retaining bolts to hold specimen tray in the HWT.
10. Ensure that the USB cord will not be damaged by movement of the wheel.
11. Before moving the wheel onto the Load Sensor or Height Indicator, make sure the wheel is centered over the Load Sensor or Height Indicator (see below).

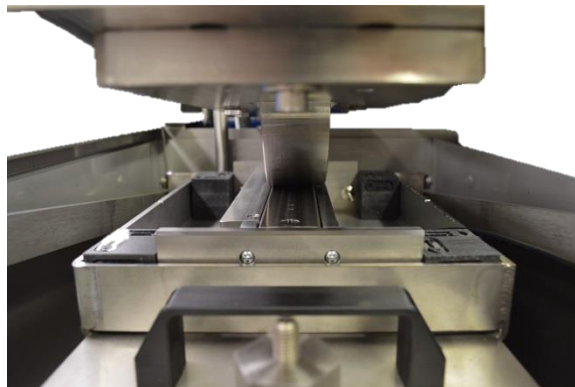

Verification Procedure

1. Select Menu > Test Type > Verification to perform a verification.

Load Verification

1. Move the wheel to the “Home” position using the SmarTracker controller.
2. Select the Load Verification tab in the HWT-Spec software. Select the wheel (left or right) you will be testing.

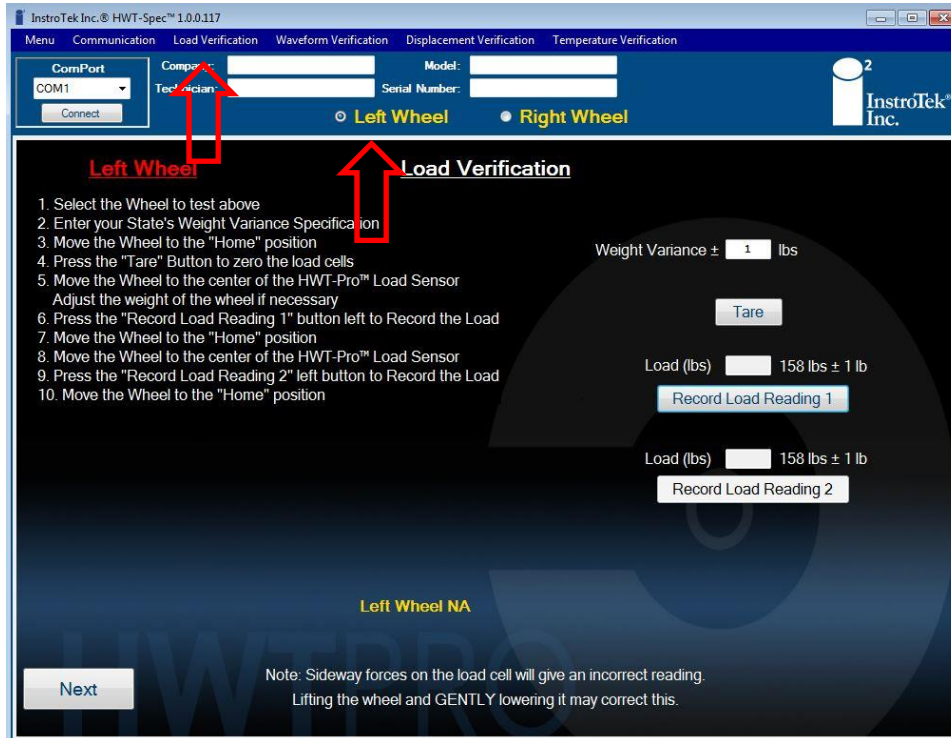

3. Insert the specimen tray with the Load Sensor installed, as described on pages 10-12.
4. Ensure the wheel is off the Load Sensor. Then, press Tare in the HWT-Spec software to zero the load cells.
5. Verify that a weight is displayed on the screen above. If the weight is not displayed, follow the steps of “Connecting to the Load Sensor”.
6. Move the wheel to touch the “+” in the center of the Load Sensor by pressing the

Manual button  to bring the wheel onto the center of the Load Sensor. Press the

button **4** more times to move the wheel through 4 steps (a complete cycle) to settle the load bar and return to the center position.

7. Press the “Record Load Reading” button in the HWT-Spec software.
8. Remove the weight from the Load Sensor by returning the wheel to the “Home”



position by pressing  on the SmarTracker controller.

9. Repeat steps 5-8 for a second measurement of the load.
10. (Optional) If an error is made while acquiring the results, the load can be acquired again by pressing the “Record Load Reading” button again.
11. Press “Next” in the HWT-Spec software to go to the Waveform Verification for the same wheel.

Waveform Verification

1. Move the wheel to the “Home” position using the SmarTracker controller.
2. Select the Waveform Verification tab in the HWT-Spec software. Select the wheel (left or right) you will be testing.

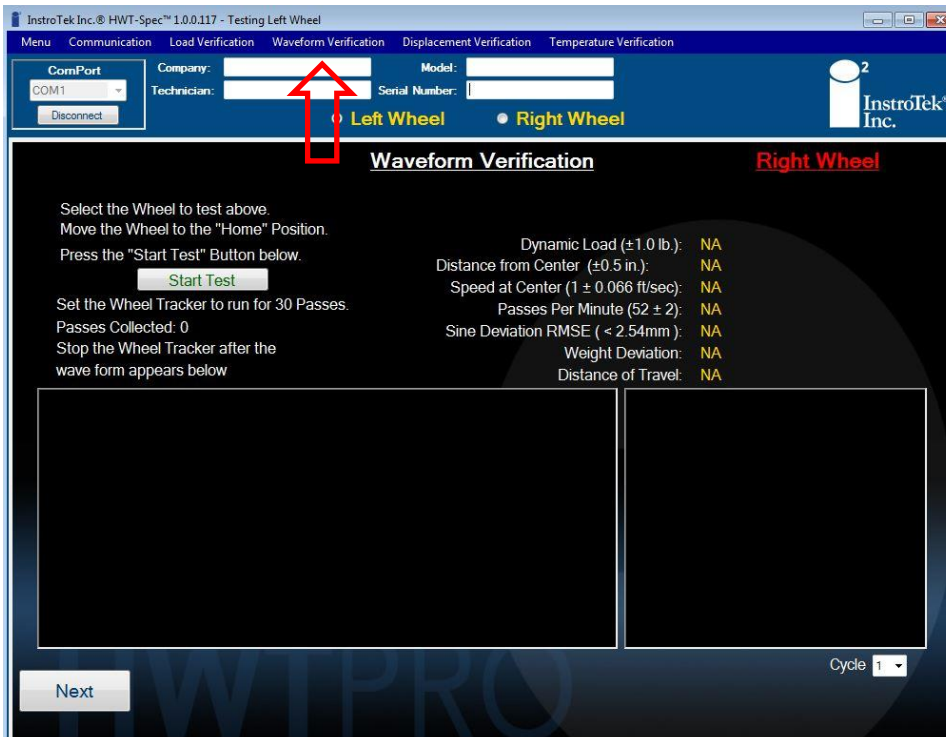

3. Press the “Start Test” button on the Waveform verification tab in the HWT-Spec software.
4. Start the HWT so that the wheels move back and forth like a normal test for at least 30 passes. The first 10 passes are ignored by the software.

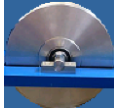

- a. Enter the main test function
 - i. Set the Speed to 52 p/min.
 - ii. Set the mode for the appropriate wheel to Air.
 - iii. Set the opposite wheel to None.

Speed:	52	p/min
Combined mode:	[empty]	
Mode - left wheel:	Air	
Mode - right wheel:	None	
Start mode:	Immediate	

- iv. Set the Pre-conditioning to 0.
 - v. Set the Passes to 30.

Pre-conditioning:	0	min
Zero passes:	2	
Pause:	0	min
Passes:	30	
Rut depth:	<input checked="" type="checkbox"/>	20.00 mm
Temperature probe:	[empty]	

- b. Start the test using the SmarTracker controller.
5. Repeat the Load and Waveform measurements for the opposite wheel.
6. (Optional) If an error is made while acquiring the waveform, the results can be acquired again by pressing the “Start Test” button and repeating the steps above.

Displacement Verification

1. Position the Height Indicator in the specimen tray with the spacer blocks described on pages 10-12.
2. Insert the specimen tray with the Height Indicator without the extra spacers and gage blocks into the Wheel Tracker.
3. Verify that Height Indicator is properly centered in the specimen tray and the wheel touches only the center steel plate. This can be done with feeler gages or inserting a piece of paper around the wheel.

4. Install spacer plates and two 10-mm gage blocks onto the Height Indicator base. Make sure the gage blocks sit tight and flush.
5. Select the Displacement Verification tab and the wheel that will be tested in the HWT-Spec software.

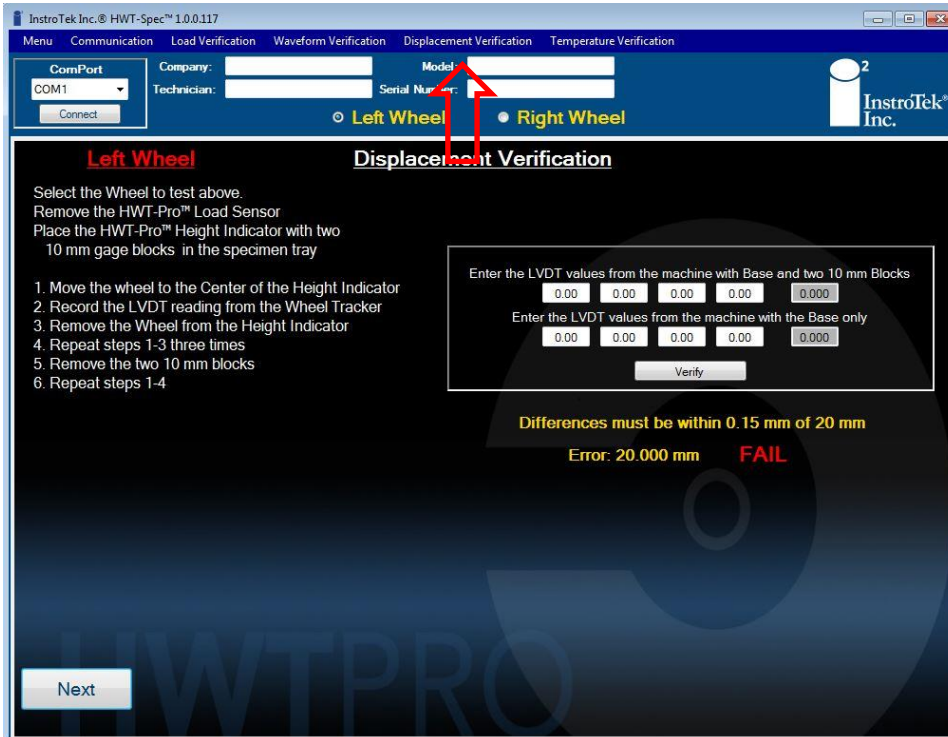

6. Move the wheel to the Center Position by pressing the Manual button  on the SmarTracker controller.
7. Enter the LVDT output from the HWT test screen in the Displacement Verification tab of the HWT-Spec software. This value should be between 10 – 30 mm.
8. Move the wheel off the Height Indicator using the SmarTracker controller and then repeat the height measurement 3 times for a given height.
9. Remove the wheel and remove all spacers and gage blocks.
10. Repeat Steps 7-9.
11. Press the Verify button in the HWT-Spec software.

NOTE: The height of the Height Indicator with the 2 gage blocks is 60 mm and without gage blocks is 40 mm. Therefore, the difference between the heights is 20 mm. The AASHTO T 324 standard allows an error of up to 0.15 mm over 20 mm, so the difference must be less than 0.15 mm.

Temperature Verification

1. Select the Temperature Verification tab in the HWT-Spec software. Select the side (left or right) you will be testing.

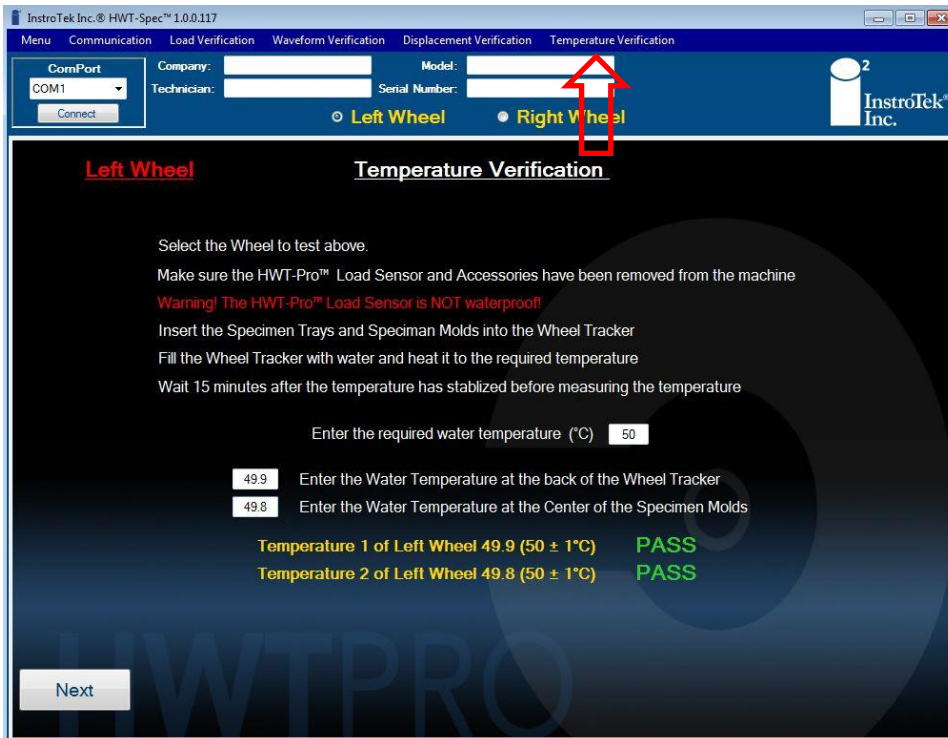

2. Check the local standard (state DOT) for the correct temperature and enter it in the specification water temperature text box.
3. Remove Load Sensor and Height Indicator from HWT water bath.
4. Insert the specimen trays and specimen molds into the HWT.
5. Fill the Wheel Tracker with water and heat it to the required temperature.
6. Wait 15 minutes after the temperature has stabilized before measuring.
7. Measure the temperature.
 - a. Back of Wheel Tracker.
 - b. Center of the specimen molds.

Calibration Procedure

Calibration involves modifying the weight or displacement transducer calibrations and then verifying the results. The HWT-Pro has the accuracy necessary to calibrate the load, displacement and temperature.

Load Calibration





1. Move the wheel to the “Home” position.
2. Select the Load Verification tab in the HWT-Spec software. Select the side (left or right) you will be testing.
3. Insert the specimen tray with the Load Sensor installed into the machine.
4. Ensure the wheel is off the Load Sensor. Then, press Tare to zero the load cells.

12. Move the wheel to touch the “+” in the center of the Load Sensor by pressing the

Manual button  to bring the wheel onto the center of the HWT-Pro. Press the button **4** more times to move the wheel through 4 steps (a complete cycle) to settle the load bar and return to the center position.

5. Add or remove plates from the wheel weights to increase or decrease the load. Each plate applies approximately 1.5 lbs to the wheel.

Displacement Calibration

1. Press  on the main menu to enter the System configuration in the SmarTracker controller. Then, press  to enter the Channel configuration menu. Enter the password (3333).
2. Select the appropriate channel to calibrate (Channel 3 or 4 – left or right, respectively).
3. Press  to go to the calibration screen.
4. Insert the specimen tray with the Height Indicator installed into the machine.
5. Enter the calibration heights in 5 mm increments (i.e., 0, 5, 10, 15 ..., 45 mm).
6. Press  on to move the arm to the center of the tray on top of the spacer plate.
7. Press  to acquire the reading from the machine for 0 mm.

-
8. Move the wheel off the spacer plate by pressing 
 9. Add the 5 mm height spacer plate.
 10. Acquire the reading for 5 mm.
 11. Repeat steps 6-10 until all the spacer plates have been used.

Verification of Displacement Calibration

1. Select **Menu > Test Type > Calibration Test**
2. Select the Displacement Calibration tab
3. Verify the heights listed on the table for increasing and decreasing height.

Verification of Calibration

After calibrating, the machine should be verified again. Follow the “Verification Procedures” to verify the calibration. Then, produce a report for calibration records.

PMW/Troxler Units

Installing the HWT-Pro in a PMW/Troxler Wheel Tracker

1. Prepare the tray used in the Wheel Tracker.
 - a. Clean the tray. All asphalt binder and mixture should be removed before installing the either the HWT-Pro the Load Sensor or Height Indicator.
 - b. Clean the wheels of any residual asphalt according to the manufacturer's recommendations.
 - c. Remove the plastic molds used to hold the asphalt mix specimens for normal testing.
2. Drain any water from the Wheel Tracker.
3. Remove the Load Sensor or Height Indicator from the case. Also, remove the appropriate plastic spacers to verify the PMW/Troxler unit, as shown in Figure 2.
4. Mark the centerline of the mold.
 - a. Place one of the specimen molds into the specimen tray. Make sure it is pushed all the way to one end of the specimen tray.
 - b. Place the 1/8 inch spacing bar against the other end of the mold towards the center of specimen tray. Mark the edge of the specimen tray. This is the center of the specimen tray.



5. Place the Load Sensor or Height Sensor in the specimen tray such that the arrow on the serial plate points toward the front of the machine (toward the user).

6. Insert the plastic spacers into the specimen tray (Figure 2).
 - a. PMW - Standard – insert the spacers into the specimen tray. Rectangular spacers (**T1**) center the crescent spacers (**T2**) that cover the ends of the Load Sensor or Height Indicator. The letter **T1** should point toward the centerline of the specimen tray in the direction of the wheel travel.
 - b. PMW - Economy – insert the crescent spacers **T2** that cover the ends of the Load Sensor or Height Indicator into the specimen tray, which is permanently fixed to the machine. Slide the spacers to one side to fit under the wheel.

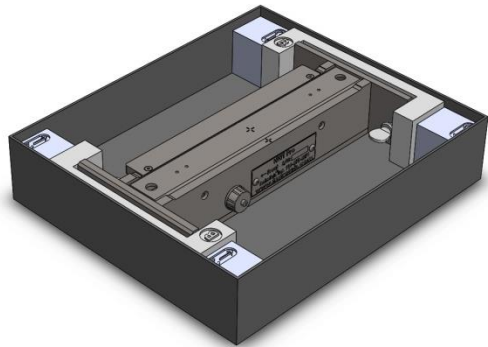

(A) PMW – Standard

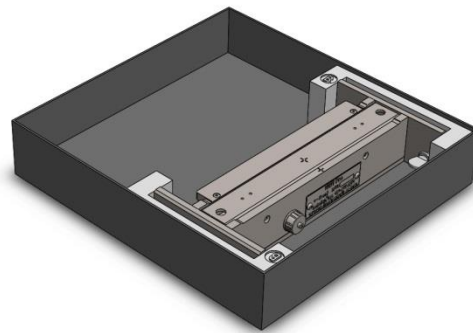

(B) PMW - Economy

Figure 2. Placement of spacers and Load Sensor or Height Indicator in HWT testing trays for PMW/Troxler Units

7. Adjust the set screws in the metal bars at the end of the HWT-Pro device so that its center matches the centerline marks on the specimen tray. Use the 1/8" spacing bar or other straight edge to verify the alignment of the centers.
 - a. Load Sensor: align the centerline marks on the specimen tray with both “+” in the center of the Load Sensor.

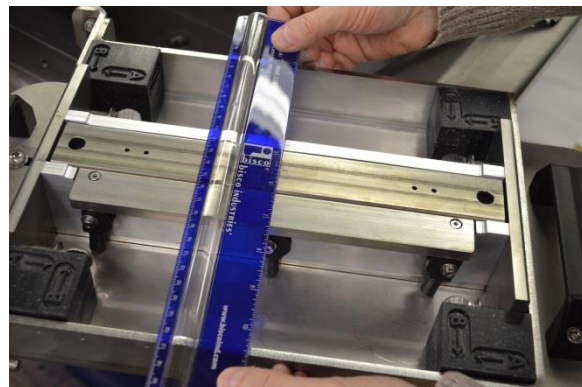
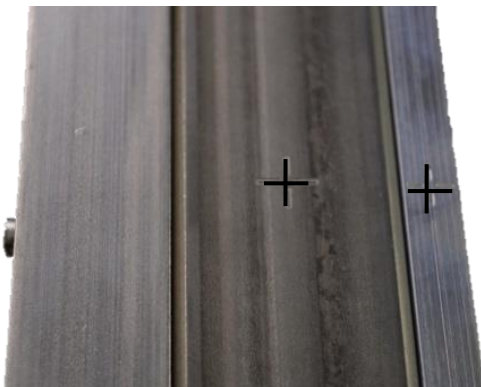

- a. Height Indicator: align the center of the screw holes in the center bar with the center marks on the specimen tray. Remove height blocks to make it easier.

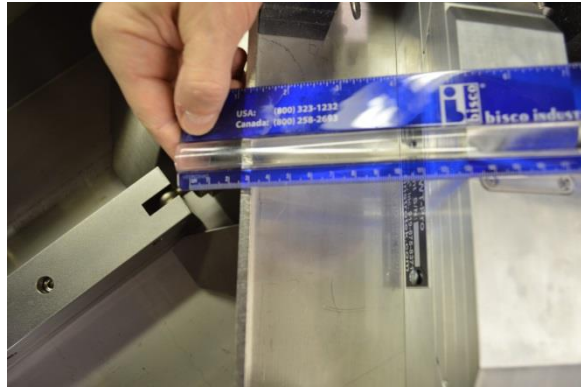
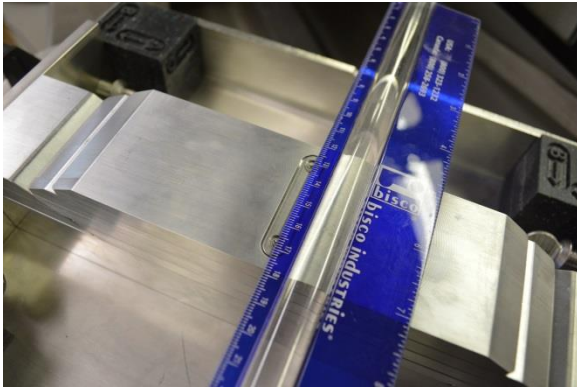

8. Attach the supplied USB cable to the Load Sensor and HWT-Pro controller.

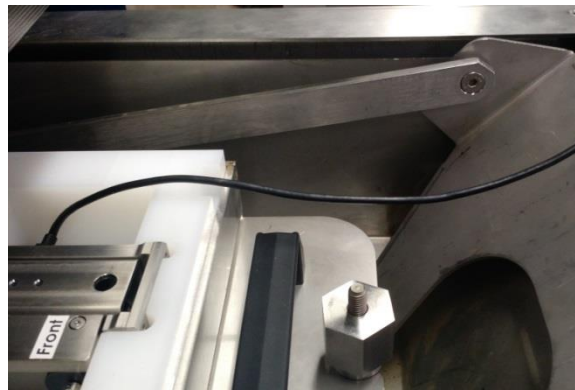

Warning! The HWT-Pro is not waterproof!

Make sure all the water has been drained before inserting the Load Sensor

9. Insert the Load Sensor or Height Indicator and specimen tray into the Wheel Tracker like it was a specimen with molds. Be sure to tighten the retaining bolts to hold specimen tray in the HWT.
10. Ensure that the USB cord will not be damaged by movement of the wheel.
11. Before moving the wheel onto the Load Sensor or Height Indicator, make sure the wheel is centered over the Load Sensor or Height Indicator (see picture below).

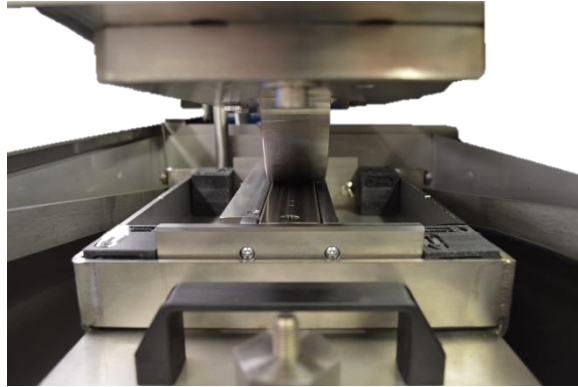

Verification Procedure

Select Menu > Test Type > Verification to perform a verification.

Load Verification

1. Insert the specimen tray with the Load Sensor installed, as described on pages 20-22.
2. Select the Load Verification tab in the HWT-Spec software. Select the wheel (left or right) you will be testing.

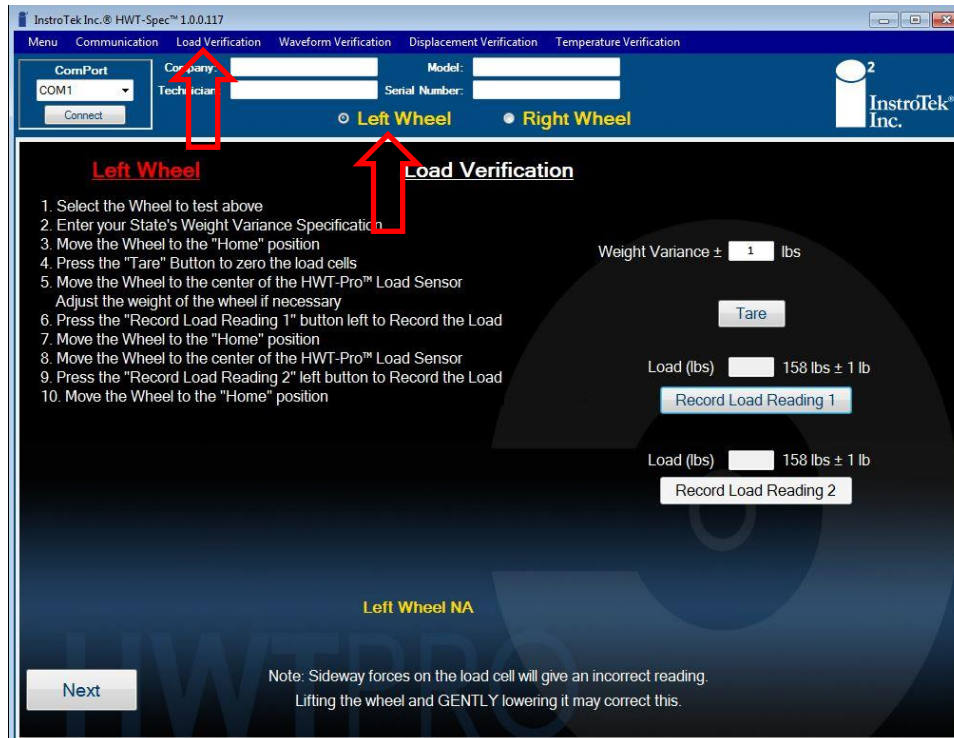

3. Ensure the wheel is off the Load Sensor. Then, press Tare in the HWT-Spec software to zero the load cells.
4. Verify that a weight is displayed in the HWT-Spec software in the screen above. If the weight is not shown, follow the steps of "Connecting to the Load Sensor".

5. Move the wheel to within ± 0.5 inches of the center of the “+” of the Load Sensor.

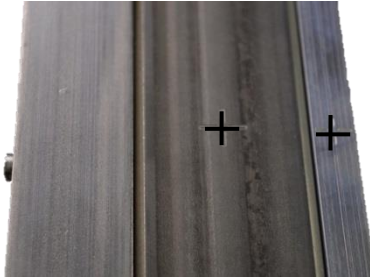

- a. Change the software setting to Manual mode in the machine software.

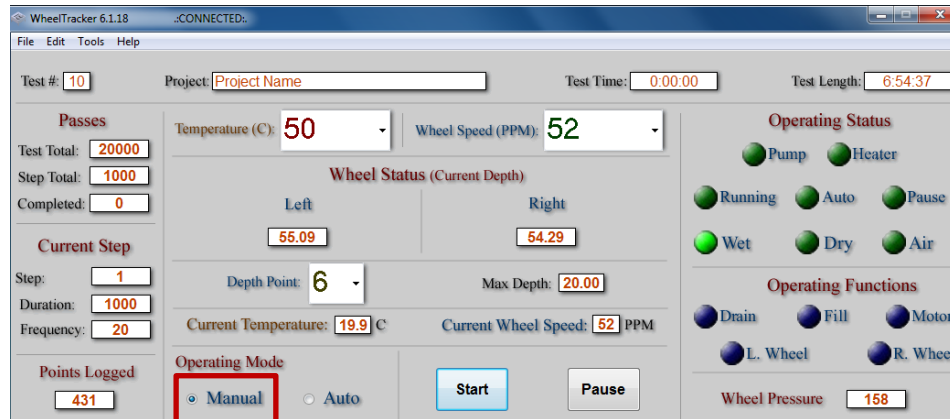

- b. Press Start to move the wheel back and forth. Make sure that in the Operating Functions block the Motor is ON.

CAUTION: Ensure no hands or clothing are in the way of the wheel movement to prevent injury.

- c. To stop it near (± 0.5 inches) the center of the Load Sensor, engage the emergency stop. To get it closer to the center may require releasing/pressing the emergency stop off/on quickly.
6. Press the “Record Load Reading” button in the HWT-Spec software.
7. Remove the weight from the Load Sensor by running wheel back and forth and re-centering it.
8. Repeat Step 6 for a second measurement of the load.
9. (Optional) If an error is made while acquiring the results, the load can be acquired again by pressing the “Record Load Reading” button again.
10. Press “Next” to go to the Waveform Verification.

Waveform Verification

1. Move the wheel to the “Rest” or “Home” position.
2. Insert the specimen tray with the Load Sensor installed.
3. Select the Waveform Verification tab in the HWT-Spec software. Select the wheel (left or right) you will be testing.

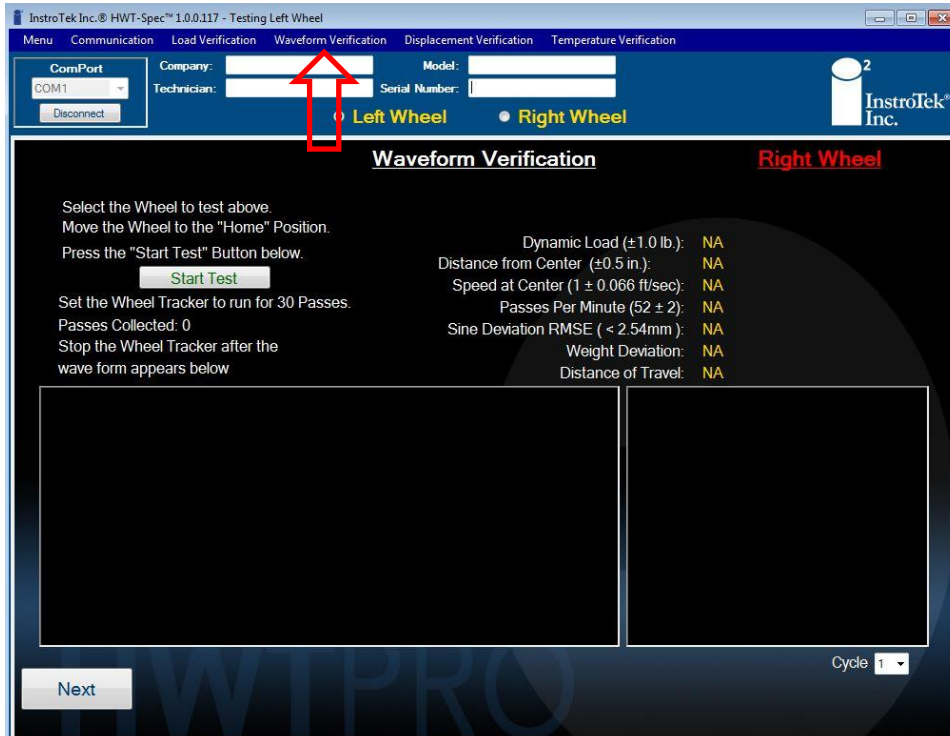

4. Press the “Start Test” button on the Waveform verification tab.
5. Place the wheel on the Load Sensor.
6. Start the HWT so that the wheels move back and forth like a normal test for at least 30 passes. The first 10 passes are ignored by the software for more consistent results.
 - a. Change the software setting to Manual mode.
 - b. Press Start to move the wheel back and forth. Make sure that in the Operating Function block the Motor is ON.
7. If a warning message such as “Warning! Overshooting the Front of the HTW-Pro!” appears, the wheel center needs to be adjusted so that it does not run off the HWT-Pro.

NOTE: The HWT-Pro can measure a 9 inch waveform offset by ± 0.5 inches from its center (up to 10 inches of travel).

 - a. Move the wheel to the “Home” position.
 - b. Move the Load Sensor forward or backward a measured distance.

- c. Add this value to the final result.
- d. Contact the manufacturer for adjustment procedures.
8. Once a waveform appears on the screen, press Pause to stop the wheel.
9. (Optional) If an error is made while acquiring the waveform, the results can be acquired again by pressing the “Start Test” button and repeating the steps above.
10. Repeat the Load and Waveform measurements for the opposite wheel (if necessary).

Displacement Verification

1. The displacement verification and calibration for the Troxler PMW is designed to be accomplished with the LVDT removed from the unit.
2. Set up the appropriate screen on the PMW as shown below.
 - a. Change the software setting to Manual mode.

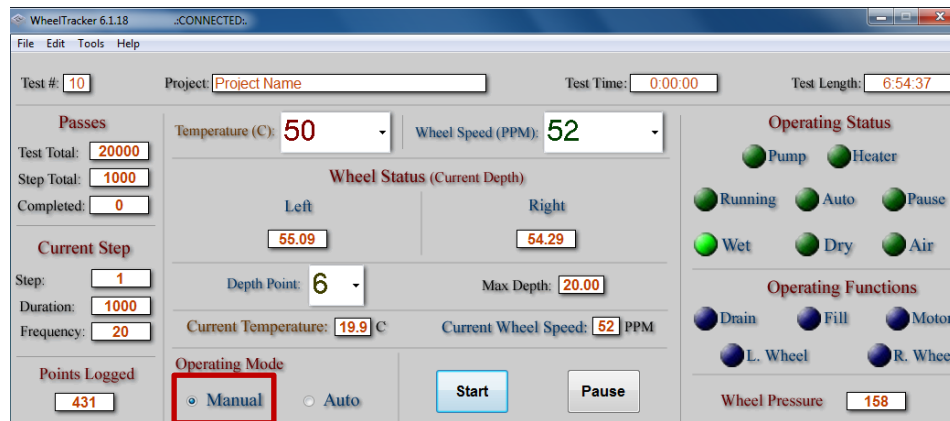

- b. Observe the LVDT reading of the Wheel Status (Current Depth) for the appropriate wheel.
3. Mark the position of the LVDT on the wheel selected so that it can be returned to its current location and then remove it.
4. Place the height Indicator with LVDT jig in a convenient location and fasten the LVDT to the jig so that the LVDT reads approximately 40 mm. Refer to the figure below.

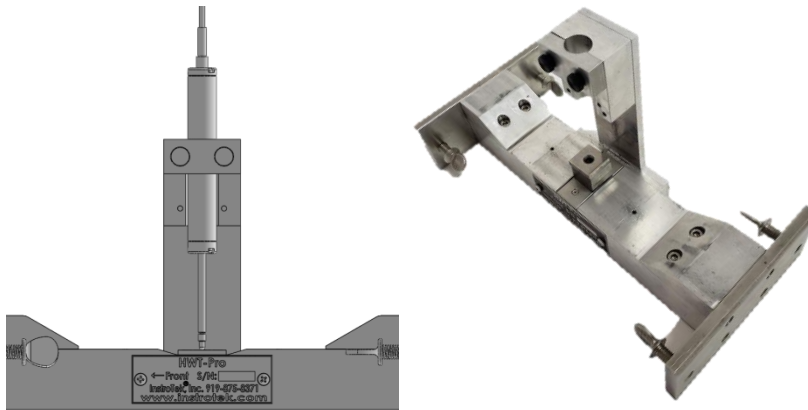

5. Place two 0.4 in gauge blocks under the LVDT; this is your starting point.
6. Record the current LVDT reading on the line “Enter LVDT values from the machine with base and two 10 mm Blocks” (In this case use the two 0.4 in blocks).
7. Remove the blocks and replace three more times to get four repeats of the measurement.
8. Remove the two 0.4 in blocks and record the current LVDT on the line “Enter the LVDT values from the machine with the Base only”.
9. Remove the blocks and replace three more times to obtain four repeats of the measurement.

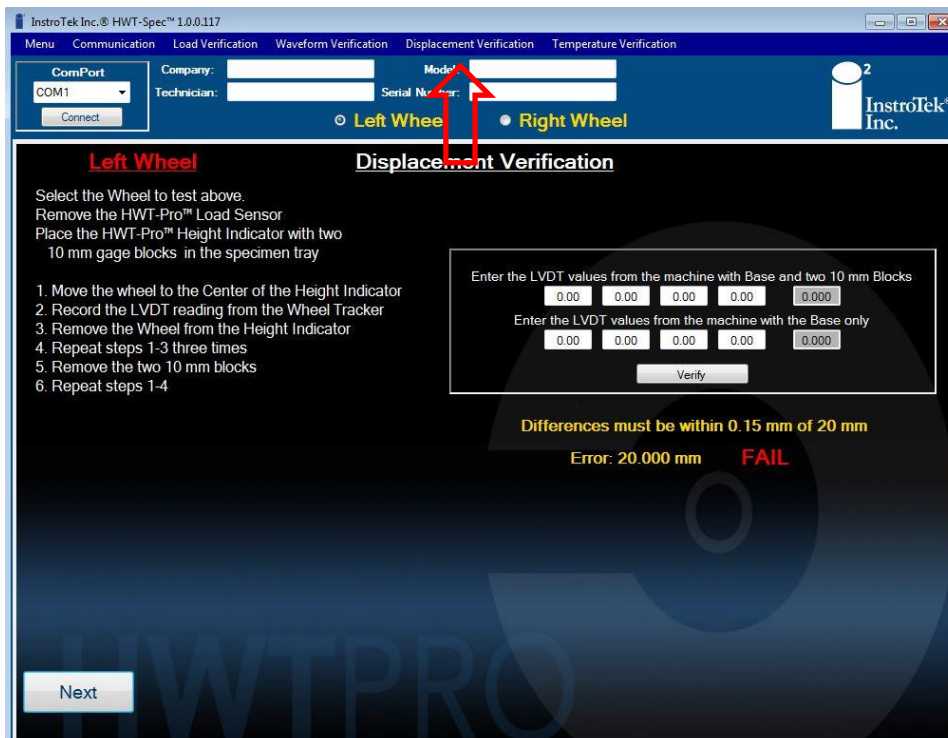

10. Select the verify tab to confirm that the error of the LVDT reading is less than 0.15 mm over a 20.32 mm displacement.

Temperature Verification

1. Select the Temperature Verification tab and which wheel you will be testing.

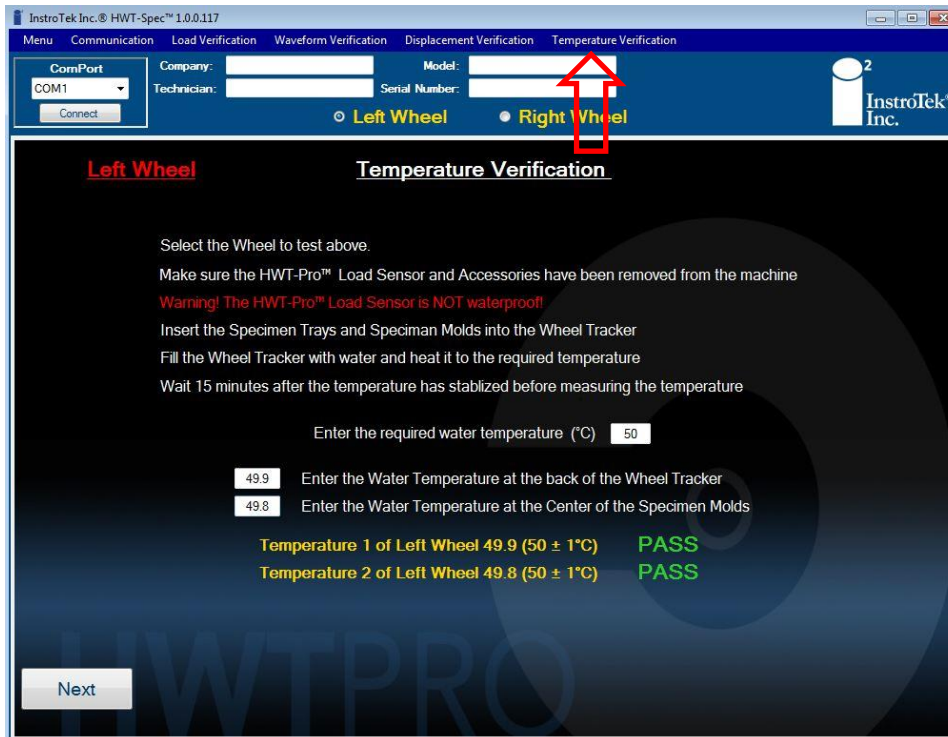

2. Check the local standard (state DOT) for the correct temperature and enter it in the specification water temperature text box.
3. Remove Load Sensor and Height Indicator from HWT water bath.
4. Insert the specimen trays and specimen molds into the HWT.
5. Fill the Wheel Tracker with water and heat it to the required temperature.
6. Wait 15 minutes after the temperature has stabilized before measuring.
7. Measure the temperature.
 - a. Back of Wheel Tracker.
 - b. Center of the specimen molds.
8. Press "Next" to generate a verification report as a PDF.

Calibration Procedure

Calibration involves modifying the weight or displacement transducer calibrations and then verifying the results. The HWT-Pro has the accuracy necessary to calibrate the load, displacement and temperature.

Load Calibration

1. Move the wheel to the “Home” position.
2. Select the Load Verification tab and which wheel you will be testing.
3. Insert the specimen tray with the Load Sensor installed into the machine.
4. Ensure the wheel is off the Load Sensor. Then, press Tare in the HWT-Spec software to zero the load cells.
5. Move the wheel to within ± 0.5 inches of the center of the “+” of the Load Sensor (See Load Verification section of the Troxler/PMW procedure for further details).
 - a. Change the software setting to Manual mode.
 - b. Press Start to move the wheel back and forth. Make sure that in the Operating Functions block the Motor is ON.

CAUTION: Ensure no hands or clothing are in the way of the wheel movement to prevent injury.

- c. To stop it near (± 0.5 inches) the center of the Load Sensor, engage the emergency stop. To get it closer to the center may require releasing/pressing the emergency stop off/on quickly.
6. Add or remove weight (such as lead shot) from the wheel weights to increase or decrease the load.

Displacement Calibration

1. Mark the position of the LVDT and then remove it from the machine.
2. Secure the LVDT in a jig. The jig should be designed with a micrometer incorporated into the holder or should hold the LVDT securely so that gauge blocks can be inserted under the LVDT without moving the LVDT.
3. Enter the calibration routine in the machine software. Contact Troxler for a password.
4. Calibration with the Troxler micrometer

-
- a. Rotate the micrometer dial until it reads 0.2 inches.
 - b. Rotate the micrometer to 1.8 inches to make sure the LVDT can read the whole span. If not, adjust the position of the LVDT.
NOTE: The LVDT output is the *current depth reading* on the HWT machine software screen.
 - c. Rotate the micrometer dial until it reads 0.2 inches.
 - d. Follow the instructions on the PWM/Troxler computer screen for calibration.
5. Using the HWT Height Indicator
- a. With the LVDT fastened to the height indicator jig place gauge blocks to equal 1.0 inch (two 0.4 inch and one 0.2 inch) on the base.
 - b. Open the Wheel Tracker software. In the menu bar at the top select Tools, in the drop down box select Calibration, in the menu under or to the side of calibration select LVDT values.
 - c. Adjust the LVDT by sliding it up or down until it reads 1.0000 ± 0.0002 inch.
 - d. Close out of LVDT Values box and Select Tools. In the drop down box select Calibration, and in the box that opens up select LVDT Offset.
 - e. Remove two 0.4 inch gauge blocks leaving behind the 0.2 in gauge block. When the LVDT reading settles select the Set Value button.
 - f. Another screen will come up asking for the micrometer to be moved to 1.0 inch. For the HWT Pro replace the two 0.4 inch blocks and when the reading settles once again select the Set Value button.
 - g. Another screen will come up asking for the micrometer to be moved to 1.8 inch. Put in the other two 0.4 inch gauge blocks to complete the process. Once the Set Value button is selected the calibration is complete.
6. PMW Calibration Check using the Height Indicator
- a. Leaving the LVDT set up from calibration, once again select the Tools menu item; in the drop down box select Calibration, and then select from the LVDT Calibration Check.
 - b. The Check will prompt you to start at 0.2 in, increase in 0.2 in increments to 1.8 in, and decrease in 0.2 in increments back to 0.2 in. It will then be repeated and the PMW software will signal if the unit passes.
 - c. A report of the Check can be generated by once again going to the Tools menu item, then in the dropdown box selecting Calibration, then in the box that pops up selecting Machine Calibration Report.

Verification of Results

After calibrating, the machine should be verified again. Follow the “Verification Procedures” to verify the calibration. Then, produce a report for calibration records.

Cox and Sons

Installing the HWT-Pro in a Cox and Sons Unit

1. Prepare the tray used in the Wheel Tracker.
 - a. Clean the tray. All asphalt binder and mixture should be removed before installing either the HWT-Pro Load Sensor or Height Indicator.
 - b. Clean the wheels of any residual asphalt according to the manufacturer's recommendations.
 - c. Remove the plastic molds used to hold the asphalt mix specimens for normal testing.
2. Drain any water from the Wheel Tracker.
3. Remove the Load Sensor or Height Indicator from the case. Also, remove the appropriate plastic spacers for the manufacturer's machine to be verified, as shown in Figure 3.
4. Mark the centerline of the mold.
 - a. Place one of the specimen molds into the specimen tray. Make sure it is pushed all the way to one end of the specimen tray.
 - b. Place the 1/8" spacing bar against the other end of the mold towards the center of specimen tray. Mark the edge of the spacing bar. This is the center of the specimen tray.



-
5. Place the Load Sensor or Height Sensor in the specimen tray such that the arrow on the serial plate points toward the front of the machine (toward the user).
 6. Insert the rectangular spacers into the specimen tray (Figure 3) to center the device. The letter C should point toward the center of the mold in the direction of the wheel travel.

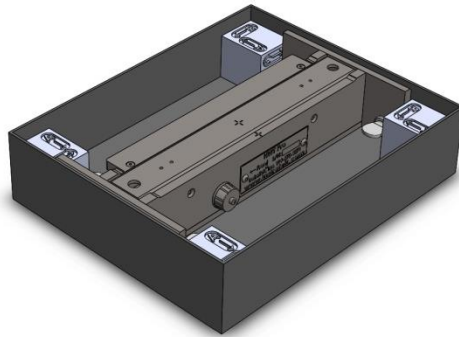
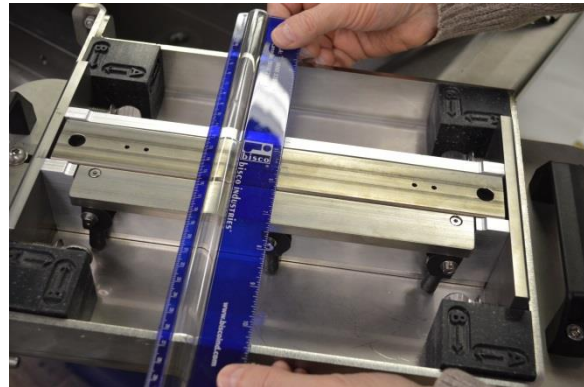
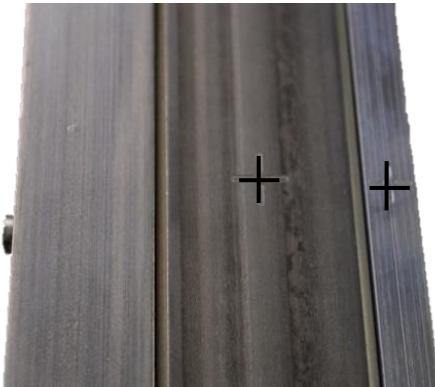

Figure 3. Placement of spacers and Load Sensor HWT specimen tray for Cox and Sons units

7. Adjust the set screws in the metal bars at the end of the device so that its center matches the centerline marks of the specimen tray. Use the 1/8" spacing bar or other straight edge to verify the alignment of the centers.
 - a. Load Sensor: align the centerline marks on the specimen tray with both "+" in the center of the Load Sensor.



-
8. Attach the supplied USB cable to the Load Sensor and HWT-Pro controller.



Warning! The HWT-Pro is not waterproof!

**Make sure all the water has been drained before
inserting the Load Sensor**

-
9. Center the wheels using the following procedure.
 - a. Start the software and enter your password, there are two modes that may be entered
 - i. Wheel Track Test which begins the sequence to perform a test
 - ii. Check System allows the control of various functions of the unit
 - b. After you have entered the password, select the "Wheel Track Test" from the menu entering test mode
 - i. A prompt will come up

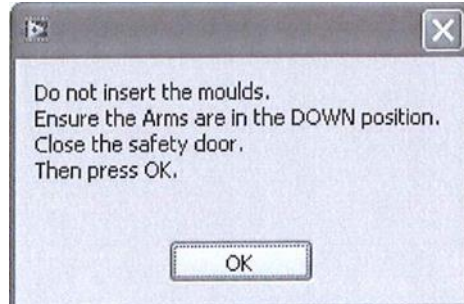

- ii. After selecting OK, another prompt will come up Start Test Center, the unit will make 4 to 5 passes and will locate the center and stop
 - iii. At this point, back out of the program and go into the Check System and raise the wheels using the arm control on the System Check Panel
10. Insert the Load Sensor or Height Indicator and specimen tray into the Wheel Tracker. Be sure to tighten the retaining bolts to hold specimen tray in the HWT
11. Ensure that the USB cord will not be damaged by movement of the wheel.
12. Before moving the wheel onto the Load Sensor or Height Indicator, make sure the wheel is centered over the Load Sensor or Height Indicator (see picture below).

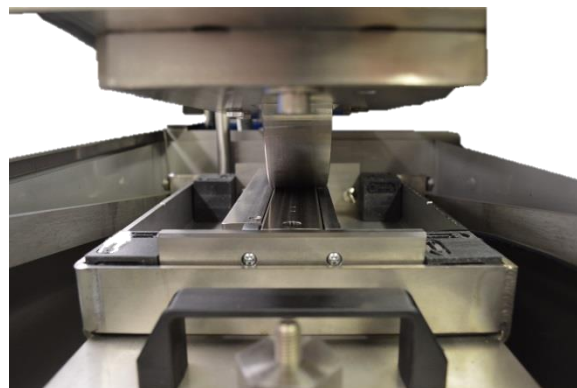

Verification Procedure

Select Menu > Test Type > Verification to perform a verification.

Load Verification

1. Center the wheels using the procedure on page 35.
2. Insert the specimen tray with the Load Sensor installed, as described on pages 32-35.
 - a. Press the UP arrow in the Arm Control box for Arm 1 or 2. See figure below.

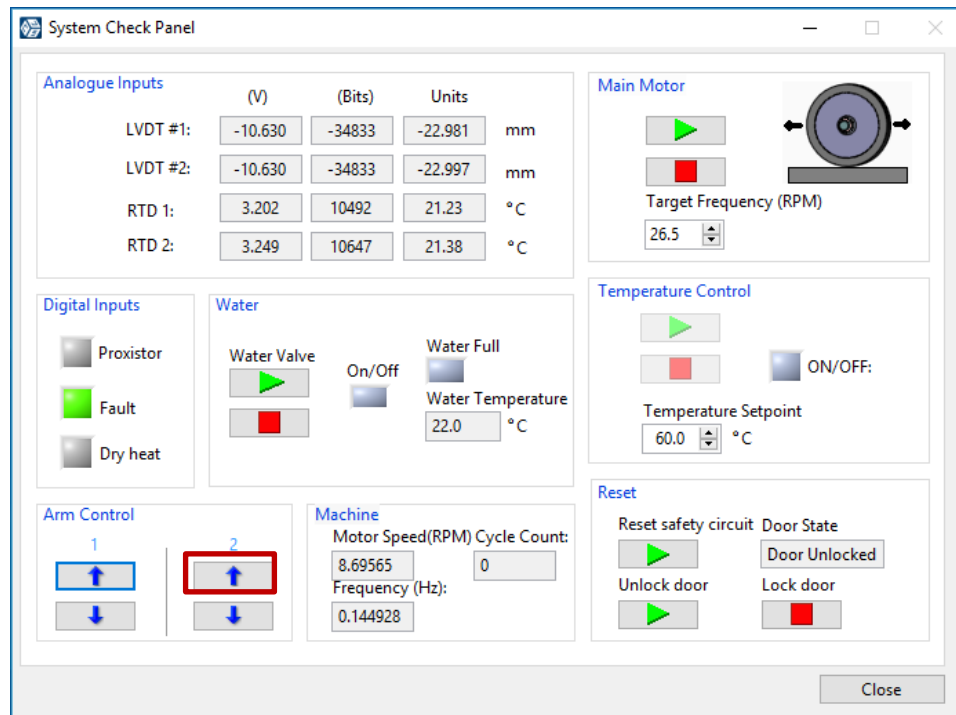

- b. Place the specimen tray with the Load Sensor into the Wheel Tracker.
3. Select the Load Verification tab in the HWT-Spec software. Select the wheel (left or right) you will be testing.

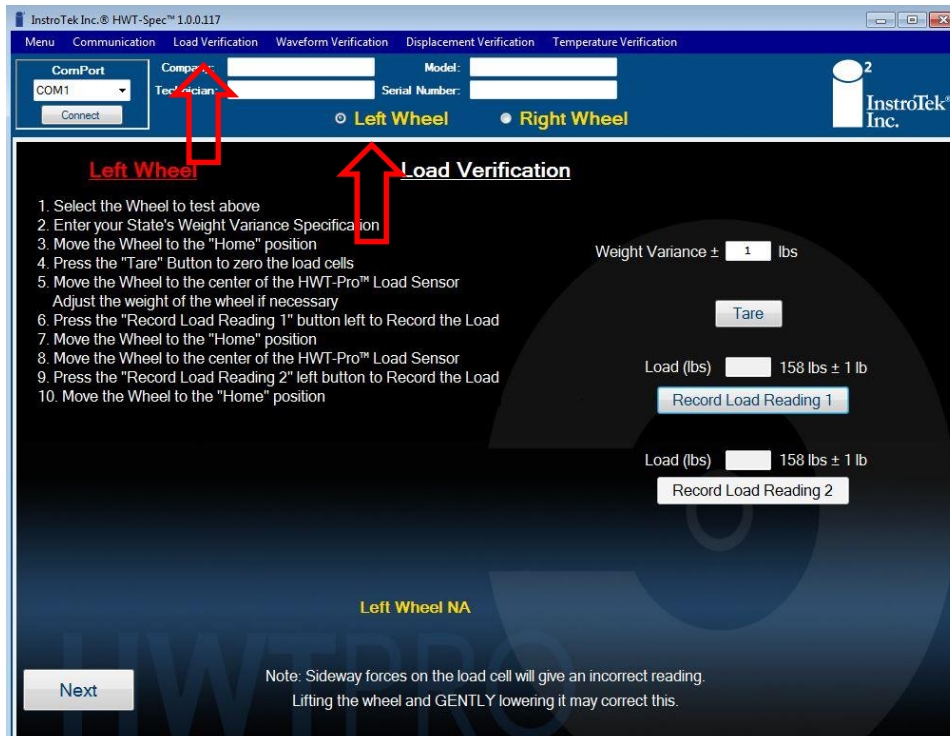

4. Ensure the wheel is off the Load Sensor. Then, press Tare in the HWT-Spec software to zero the load cells.
5. Verify that a weight is shown on the screen above. If a weight is not shown, follow the steps of “Connecting to the Load Sensor”.
6. Press the DOWN arrow in the Arm Control box to lower the wheel onto the “+” in the center of the Load Sensor.

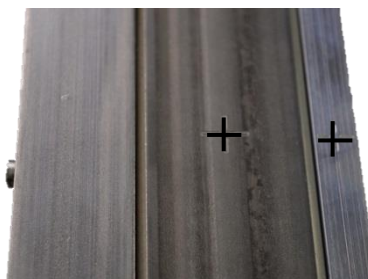

7. Press the “Record Load Reading” button in the HWT-Spec software.
8. Raise the wheel and repeat Steps 6-7 for a second measurement of the load.
9. (Optional) If an error is made while acquiring the results, the load can be acquired again by pressing the “Record Load Reading” button.

Waveform Verification

1. Insert the specimen tray with the Load Sensor installed.
2. Select the Waveform Verification tab in the HWT-Spec software. Select the wheel (left or right) you will be testing.

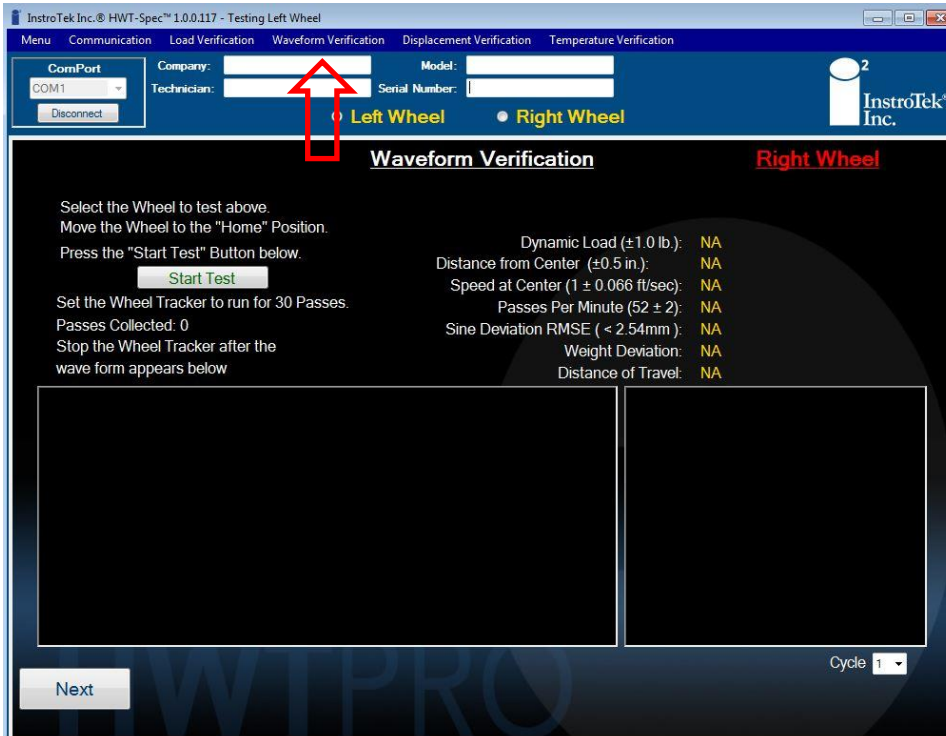

3. Raise the wheel off the Load Sensor using the Arm Control in the Check System Panel.
4. Press the "Start Test" button on the Waveform Verification tab in the HWT-Spec software.
5. Start the HWT so that the wheels move back and forth like a normal test for at least 30 passes.
 - a. Press Play on the Main motor to start moving the wheels.
 - b. Lower the appropriate wheel by pressing the DOWN arrow in the Arm Control Box.
6. If a warning message such as "Warning! Overshooting the Front of the HTW-Pro!" appears, either the mold needs to be adjusted or the wheel center needs to be adjusted so that it does not run off the HWT-Pro.

NOTE: The HWT-Pro can measure a 9 inch waveform offset by ± 0.5 inches from its center (up to 10 inches of travel).
7. Once a waveform appears on the screen, raise the wheel off the Load Sensor and stop the main motor.
8. (Optional) If an error is made while acquiring the waveform, the results can be acquired again by pressing the "Start Test" button and repeating the steps above.

Displacement Verification

1. Mark the position of the LVDT to be removed from the unit.
2. Place the height indicator along with LVDT jig in close proximity to the machine making sure it is level and secure. Fasten the LVDT into the jig as shown in the figure below.

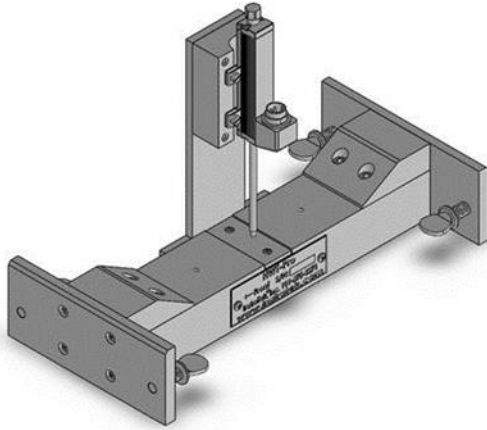

3. Adjust the LVDT such that the LVDT reads between -12.5 and -7.5 mm.
4. Insert two 10 mm gauge blocks and record the LVDT reading in the first upper box.
5. Remove the two 10 mm gauge blocks and record the LVDT reading in the first lower box.
6. Repeat this process until all four upper boxes have a number entered and all four lower boxes have a number.
7. Select the Verify button in the HWT-Spec software to verify.

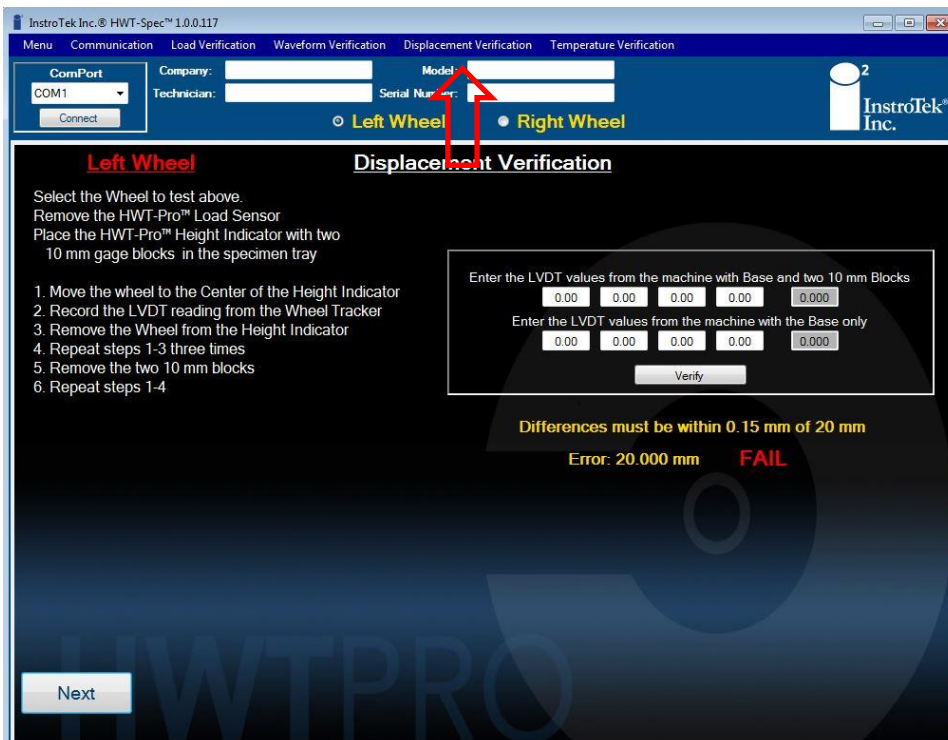

Temperature Verification

1. Select the Temperature Verification tab and which wheel you will be testing.

The screenshot shows the 'Temperature Verification' window in the InstronTek HWT-Spec software. The window title is 'InstronTek Inc. © HWT-Spec™ 1.0.0.117'. The menu bar includes 'Menu', 'Communication', 'Load Verification', 'Waveform Verification', 'Displacement Verification', and 'Temperature Verification'. The top navigation bar has 'ComPort' (COM1), 'Company', 'Model', 'Technician', and 'Serial Number' fields, along with a 'Connect' button. Below this, there are radio buttons for 'Left Wheel' and 'Right Wheel', with a red arrow pointing to 'Right Wheel'. The main content area is titled 'Left Wheel' and 'Temperature Verification'. It contains the following text: 'Select the Wheel to test above.', 'Make sure the HWT-Pro™ Load Sensor and Accessories have been removed from the machine', 'Warning! The HWT-Pro™ Load Sensor is NOT waterproof!', 'Insert the Specimen Trays and Speciman Molds into the Wheel Tracker', 'Fill the Wheel Tracker with water and heat it to the required temperature', and 'Wait 15 minutes after the temperature has stabilized before measuring the temperature'. There is an input field for 'Enter the required water temperature (°C)' with the value '50'. Below this are two input fields: '49.9 Enter the Water Temperature at the back of the Wheel Tracker' and '49.8 Enter the Water Temperature at the Center of the Specimen Molds'. The results are displayed as 'Temperature 1 of Left Wheel 49.9 (50 ± 1°C) PASS' and 'Temperature 2 of Left Wheel 49.8 (50 ± 1°C) PASS'. A 'Next' button is at the bottom left.

2. Check the local standard (state DOT) for the correct temperature and enter it in the specification water temperature text box.
3. Remove Load Sensor and Height Indicator from HWT water bath.
4. Insert the specimen trays and specimen molds into the HWT.
5. Fill the Wheel Tracker with water and heat it to the required temperature.
6. Wait 15 minutes after the temperature has stabilized before measuring.
7. Measure the temperature.
 - c. Back of Wheel Tracker.
 - d. Center of the specimen molds.

Calibration Procedure

Calibration involves modifying the weight or displacement transducer calibrations and then verifying the results. The HWT-Pro has the accuracy necessary to calibrate the load, displacement and temperature.

Load Calibration

1. Center the wheels using the procedure on page 35.
2. Select the Load Verification tab and which wheel you will be testing.
3. Insert the specimen tray with the Load Sensor installed.
 - a. Press the UP arrow in the Arm Control box for Arm 1 or 2.
 - b. Place the specimen tray with the Load Sensor into the Wheel Tracker.
4. Ensure the wheel is off the Load Sensor. Then, press Tare to zero the load cells.
5. Press the DOWN arrow in the Arm Control box to lower the wheel onto the “+” in the center of the Load Sensor.
6. Slide the wheel weights forward or backward to increase or decrease the weight of the wheel.

Displacement Calibration

1. Mark the position of the LVDT and then remove it from the machine.
2. Secure the LVDT in a jig. The jig should be designed with a micrometer incorporated into the holder or should hold the LVDT securely so that gauge blocks can be inserted under the LVDT without moving the LVDT.
3. Enter the calibration routine in the machine software.

To calibrate the displacement transducer, select Step 4 OR 5.

4. Calibrate with the micrometer
 - a. Rotate the micrometer dial until it reads a whole mm.
 - b. Rotate the micrometer 40 mm to make sure the LVDT can read the whole span.
If not, adjust the position of the LVDT.
NOTE: The LVDT output is shown as a voltage between -10 and +10 V.
 - c. Rotate the micrometer dial back 40 mm.
5. Calibrate with the Height Indicator
 - a. Attach the LVDT calibration frame to the Height Indicator base
 - b. Attach the LVDT by screwing it to the calibration stand.

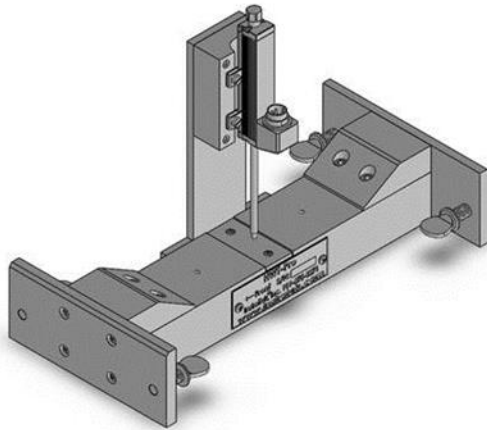

- c. Start with the bottom plate and record the LVDT voltage output. Make sure the LVDT is in its measurement range.
 - d. Insert two 10-mm gage blocks. Then, record the LVDT voltage output.
 - e. Insert two additional 10-mm gage blocks. Then, record the LVDT voltage output.
6. Calculate the gain and offset.
- a. Using Excel, plot actual height spacers values of 0, 20, and 40 mm on the y-axis and the corresponding voltages on the x-axis.
 - b. Right-click on the data and select “Add Trendline”. Select “Display Equation on Chart”.
 - c. The slope (mm/displacement) is the number before “x”. (For example: $y = 4.5x + 10$, the slope is 4.5)

Verification of Results

After calibrating, the machine should be verified again. Follow the “Verification Procedures” to verify the calibration. Then, produce a report for calibration records.

Saving/Printing the Results

The HWT-Spec software generates a report that can be printed using a printer and saved as a PDF for records and/or emailing or a .csv data file for further analysis. An example of the report from a HWT-Pro Verification is seen below.

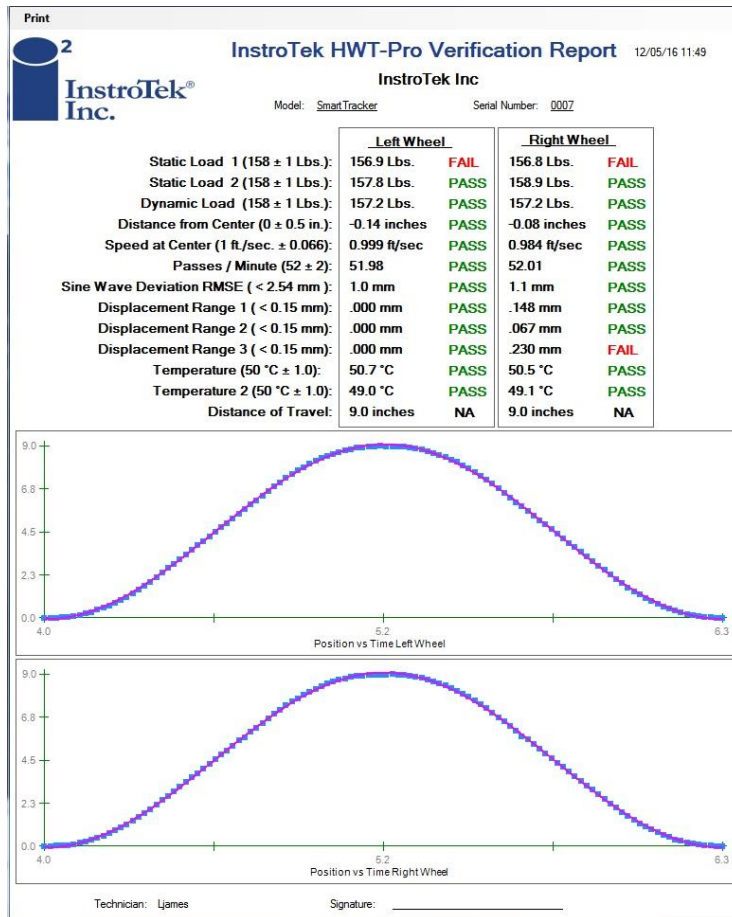

The report can be printed and/or saved by clicking the “Menu” drop down.

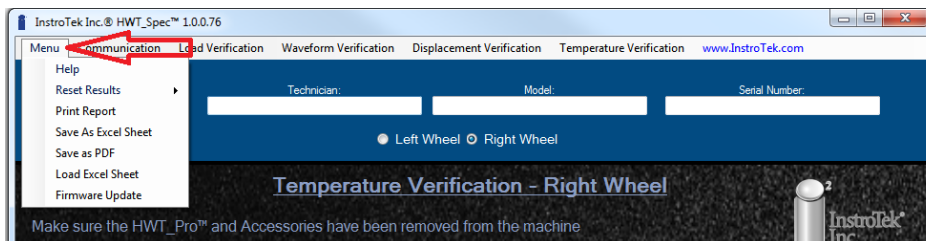

The options in the menu are described below:

- Help – shows the help file
- Test Type – selects the test type: Verification or Calibration

-
- Reset Results – resets the results
 - Print Report – prints the report using an installed printer
 - Save Excel – saves the results as comma separated (.csv) file
 - Save PDF – saves the results as PDF
 - Load Excel Sheet – loads previous test results from .csv file
 - Firmware Update – updates HWT-Pro firmware
 - Load Company Logo – permits user to load a logo for the report

Reviewing data saved to an Excel sheet

1. From the drop-down menu, click the Load Excel Sheet.
2. Browse to find the .csv file you wish to review and select it.
3. The data will be loaded and displayed on the appropriate pages.

Updating the Firmware in the HWT

1. Download the new firmware from InstroTek Inc. (for example, HWT Pro 2_00.cyacd), and save it to a folder on the PC/Laptop that the HWT-Spec software is running on.
2. Connect the USB cable to the Load Sensor and the computer.
3. Launch the HWT-Spec software and confirm the software has established communication.
4. Click the drop-down Menu and select “Firmware Update”.
5. Browse to where the update file is saved and select it.
6. Wait for confirmation from the software that the upload has completed.
7. **WARNING!** Do not turn off the PC/Laptop or shutdown the software until the upload has completed!



Contact us for top quality, best value and superior service!

email: sales@instrotek.com ✦ visit: InstróTek.com

CALL A LOCATION NEAR YOU:

Headquarters: **Raleigh, NC** phone: **919.875.8371**

Richmond, VA phone: **804.353.9499** ✦ **Bensalem, PA** phone: **215.645.1064**

Grand Rapids, MI phone: **616.726.5850** ✦ **Denver, CO** phone: **303.955.5740**

Las Vegas, NV phone: **702.270.3885** ✦ **Concord, CA** phone: **925.363.9770**