

LINDEN TABLE LAMP

DUNN

DESCRIPTION

The Linden Table Lamp features a linen shade and body, wood base, and brass details. A study in duality, the piece explores the balance between soft, flowing fabric and disciplined conical forms.

DETAILS

Lead Time | 8-10 Weeks

Materials | Linen, brass, steel, hardwood

Weight | 4.5 lbs

Dimensions | 25" H x 21" Diameter

Lamping | 120V/60Hz, E26 socket

Made In | USA

FRONT VIEW

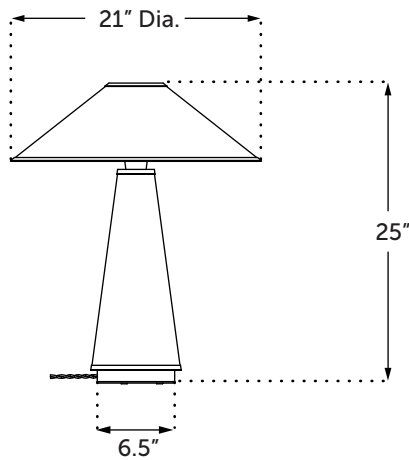

FINISHES

 | Cream Linen (CL)

 | Walnut Base (W)

 | Brass Details (B)

BULBS

Sold separately. Please visit our website for details. Many styles of bulbs work with our fixtures. Please refer to the lamping specifications to determine compatibility.

CUSTOMIZATION

No customization currently available for this product.

ASSEMBLING PRODUCT SKUS

LND-TL - **CL** - **W** - **B**
model linen wood details

CERTIFICATIONS



Finish samples sold online.

Each piece is built to order.

Designed by Studio DUNN, 2018

(401) 400-0206
info@studiodunn.com
www.studiodunn.com

310 Bourne Ave
Building #1
Rumford, RI 02916

For quotes & custom inquiries
please contact Studio DUNN:
info@studiodunn.com