

SELECT DESIRED GAS:

- NATURAL GAS
- PROPANE

SELECT DESIRED FINISH:

- 316 MARINE GRADE STAINLESS STEEL
- BLACK POWDER COAT
- CUSTOM POWDER COAT SPECIFY: _____

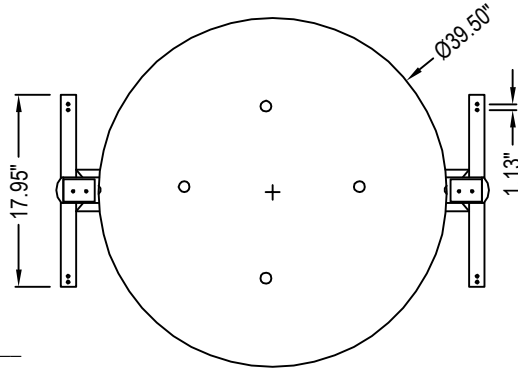

FRONT ELEVATION

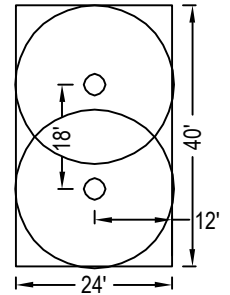

TYPICAL COVERAGE
TWO HEATERS

TECHNICAL SPECIFICATIONS:

- HIGH FIRE - 53,000BTU/HR (NG)
47,000BTU/HR (LPG)
- LOW FIRE - 46,000BTU/HR (NG)
40,000BTU/HR (LPG)
- GAS SUPPLY PRESSURE: NG -
6.5" W.C. (MIN), 14.0" W.C. (MAX)
LPG: 10.8" W.C. (MIN), 14.0" W.C.
(MAX)
- ELECTRICAL SUPPLY: 24 VOLTS, 0.8
AMPS
- DIRECT SPARK IGNITION WITH 3-TRY
LOCK OUT & AUTOMATIC RE-LIGHT

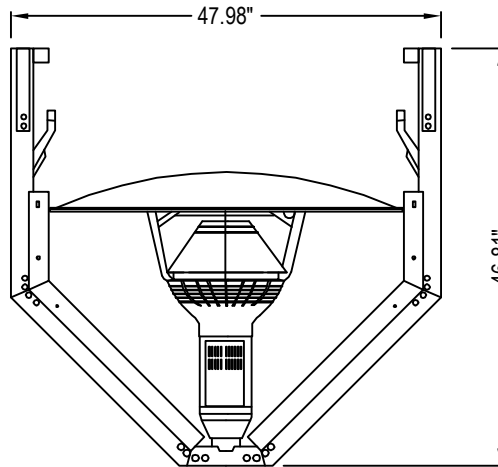

FRONT ELEVATION
MODEL GA301-H

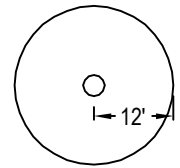

TYPICAL COVERAGE
ONE HEATER

WARRANTY:

- 3 YEARS ON 316 STAINLESS STEEL
EMITTER
- 1 YEAR ON ALL OTHER PARTS

NOTES:

1. INSTALLATION TO BE COMPLETED IN ACCORDANCE WITH MANUFACTURER'S SPECIFICATIONS.
2. DO NOT SCALE DRAWING.
3. THIS DRAWING IS INTENDED FOR USE BY ARCHITECTS, ENGINEERS, CONTRACTORS, CONSULTANTS AND DESIGN PROFESSIONALS FOR PLANNING PURPOSES ONLY. THIS DRAWING MAY NOT BE USED FOR CONSTRUCTION.
4. ALL INFORMATION CONTAINED HEREIN WAS CURRENT AT THE TIME OF DEVELOPMENT BUT MUST BE REVIEWED AND APPROVED BY THE PRODUCT MANUFACTURER TO BE CONSIDERED ACCURATE.
5. CONTRACTOR'S NOTE: FOR PRODUCT AND COMPANY INFORMATION VISIT www.CADdetails.com/info AND ENTER REFERENCE NUMBER 5029-006.

EVENGLO HANGING SERIES: MODEL **GA301H**