

ASTRA SERIES

HIGH-EFFICIENCY FIREPLACE



supr^{me}

THE FUTURE OF FIRE

As the industry leader of clean burn technology, we have been creating heating solutions that combine unmatched engineering sophistication, quality craftsmanship and timeless appeal for more than 35 years.

Our products boast patented mechanisms that support unparalleled functionality and environmentally responsible performance.

Our diverse collection ranges from classic designs to contemporary styles, ensuring seamless integration into any decor that will enrich your home with comfort and warmth for a lifetime.

Note:

Information and images contained in this catalog are subject to change and should be used for reference only. All installations should be done in accordance to the specifications detailed in the owner's manual.





ASTRA-24 CLEAN FACE

CAST-IRON PANELS

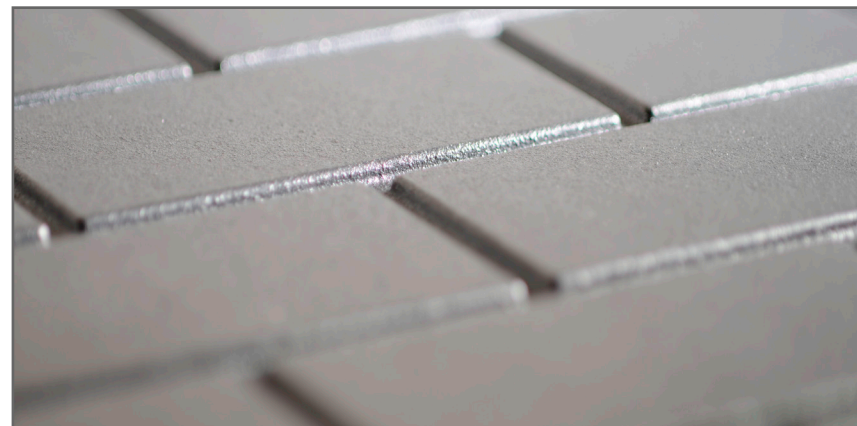

The Astra's stainless steel firebox is lined with cast-iron panels for an extra layer of durability and strength. Designed to provide long-lasting heat and thermal protection, these industry-first, decoratively stamped panels also provide the added benefit of the timeless beauty of cast iron. Forged in fire, tempered with time, the Astra offers a lifetime of warmth.

ASTRA 24



HIGH-EFFICIENCY FIREPLACE



SPECIFICATIONS*	Heat Capacity	1,500 square feet	Certifications	Meets 2020 EPA wood emission limits with EPA test method 28R, UL 127 and ULC S610
	Max. Heat Output	75,000 BTUs/hour (based on a 20 lb load of wood)	Emissions	1.8 g/h
	EPA Firebox Size	2.4 cubic feet	Glass Dimensions	24" x 13½"
	Chimney	6 inch listed to UL 103/ ULC S629 standards	Patent Numbers	7/325,547 & 9/476,593

*Same specifications for both Clean Face and Traditional

ASTRA 32

EPA 2020



ASTRA 32 CLEAN FACE

HIGH-EFFICIENCY FIREPLACE

SPECIFICATIONS*	Heat Capacity	1,000 to 2,000 square feet	Certifications	Meets 2020 EPA wood emission limits with EPA test method 28R, UL 127 and ULC S610
	Max. Heat Output	100,000 BTUs/hour	Emissions	1.47 g/hr
	EPA Firebox Size	3.2 cubic feet	Glass Dimensions	22 7/8" x 15 1/2"
	Chimney	6 inch listed to UL 103/ ULC S629 standards	Patent Numbers	7/325,547 & 9/476,593

*Same specifications for both Clean Face and Traditional

ASTRA 38



HIGH-EFFICIENCY FIREPLACE



ASTRA 38 TRADITIONAL

SPECIFICATIONS*	Heat Capacity	1,000 to 2,500 square feet	Certifications	Meets 2020 EPA wood emission limits with EPA test method 28R, UL 127 and ULC S610
	Max. Heat Output	125,000 BTUs/hour	Emissions	1.85 g/hr
	EPA Firebox Size	3.8 cubic feet	Glass Dimensions	22 7/8" x 15 1/2"
	Chimney	6 inch listed to UL 103/ ULC S629 standards	Patent Numbers	7/325,547 & 9/476,593

*Same specifications for both Clean Face and Traditional



REMOVABLE ASH LIP

Offering another layer of protection against ashes, this removable accessory can be attached below the door to prevent spills when the fireplace is opened.

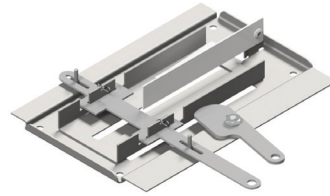

PATENTED AUTOMATIC AIR CONTROL

This patented, user-friendly mechanism automatically reduces the amount of combustion air introduced during ignition to the desired burn rate setting. The result is a beautifully consistent fire burning to its full capacity.

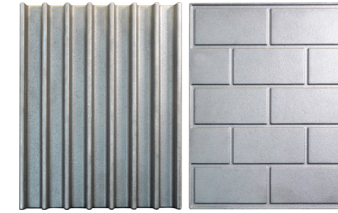

REVERSIBLE CAST-IRON PANELS

Crafted with care, our heavy-duty cast iron panels are stamped with a brick pattern on one side and a flowing contemporary design on the other. These reversible panels provide a versatile design that is as beautiful as it is functional.

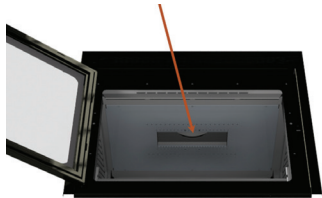

CHIMNEY SWEEPING CAP

Located on the baffle, this convenient feature allows the chimney to be easily accessed for cleaning, without requiring the removal of any components.



UNIQUE DOOR OPERATION

Our finely crafted door handle has an ergonomic design and keeps the door shut by means of a latch for a secure operation.

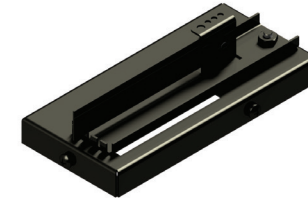

PATENTED VARIABLE AIR CONTROL

A variable amount of secondary air is introduced into the firebox that mixes with the rising gases of the wood. The result is an appealing and unique arrangement of flames that prolongs combustion, increases efficiency and minimizes emissions.



INNOVATIVE BAFFLE DESIGN

Most EPA units have secondary air tubes that reduce the firebox height and require maintenance. Our unique design allows secondary air to enter through a perforated baffle offering an unimpeded view of the fire all while increasing the efficiency and combustion.



PREMIUM QUALITY BLOWERS (125 CFM EA.)

This powerful yet whisper-quiet system effortlessly distributes heat over significant distances. As the combustion progresses, the high-quality blower automatically activates and is set using the variable speed controller.

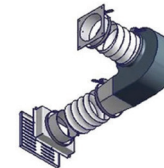

HOT AIR SYSTEM

This option helps distribute warm air to different floors or areas as far as 25 feet away.

ASTRA 24

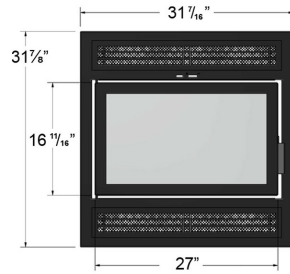

Traditional

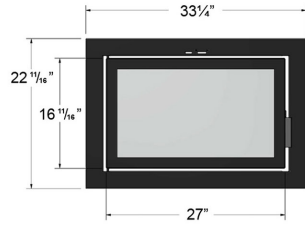

Clean Face

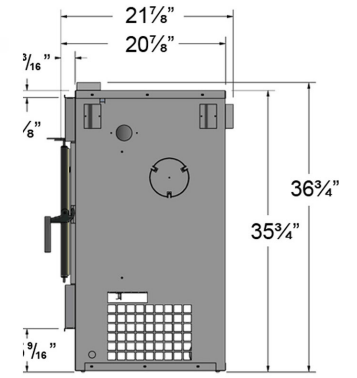
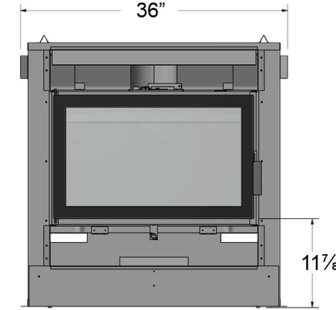
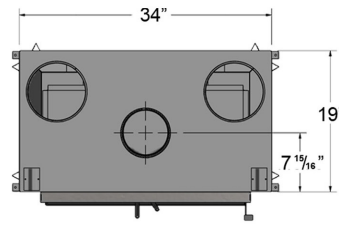

ASTRA 32

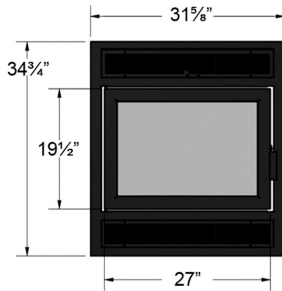

Traditional

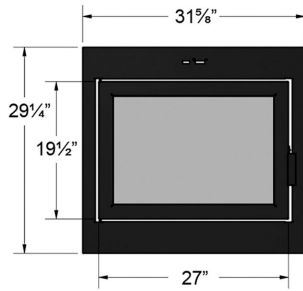

Clean Face

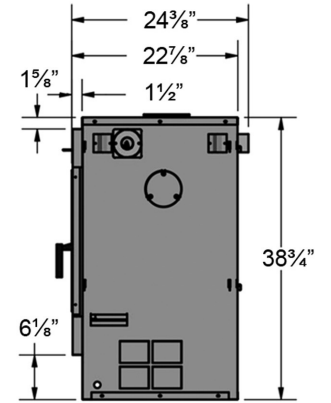
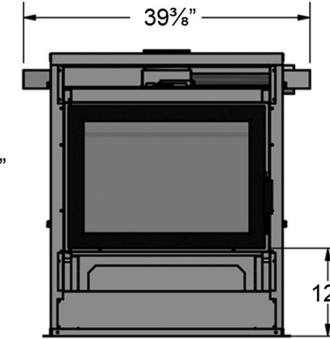
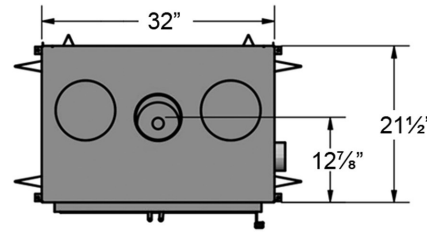

ASTRA 38

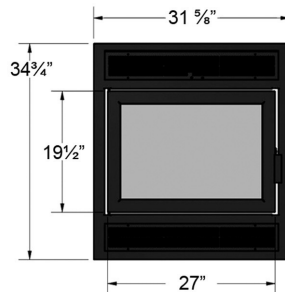

Traditional

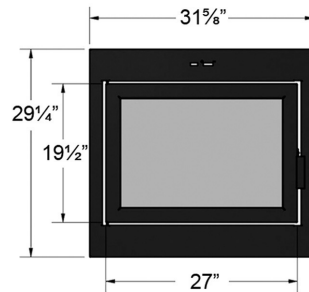

Clean Face

