

Specifications

Model	BTU	Width		Height		Depth		Viewing Area
		Actual	Framing	Actual	Framing	Actual	Framing	
NEFB42H-BS	5,000 / 10,000	42 1/8"	41 1/2"	31 7/8"	31 1/4"	14"	13 3/4"	39 7/8" x 25 7/8"

Dimensions

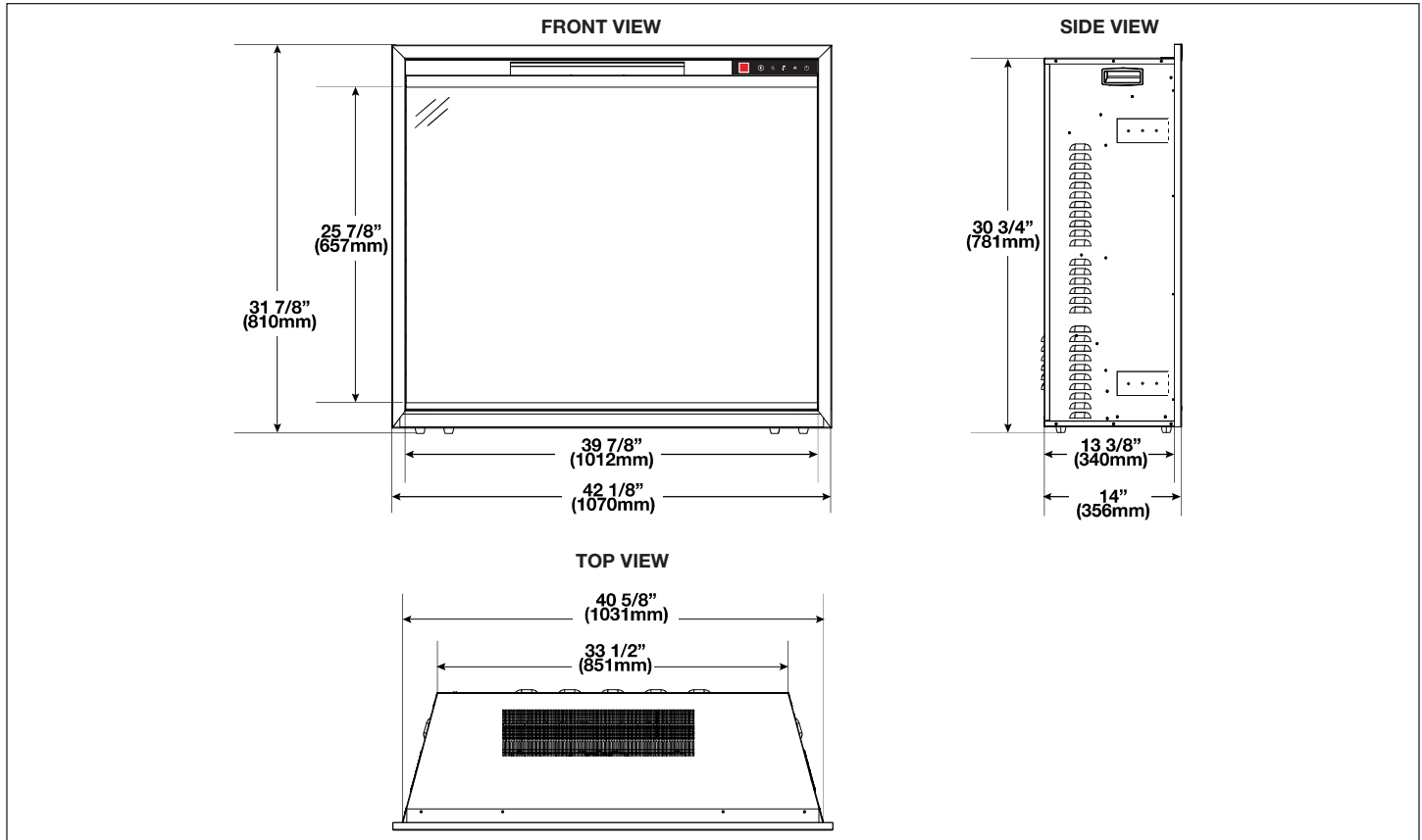

Rough Framing

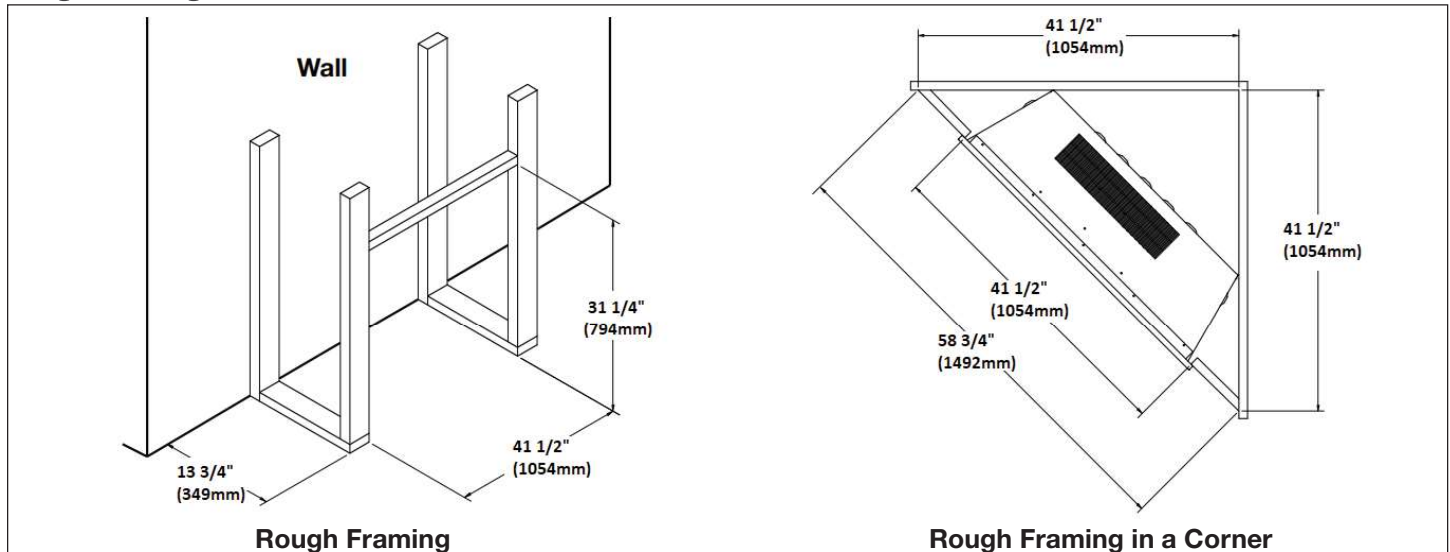

Product information provided is not complete and is subject to change without notice. Please consult the installation manual for the most up to date installation information.

Minimum Mantel Clearances

⚠ WARNING

- When using paint or lacquer to finish the mantel, the paint or lacquer must be heat resistant to prevent discolouration.

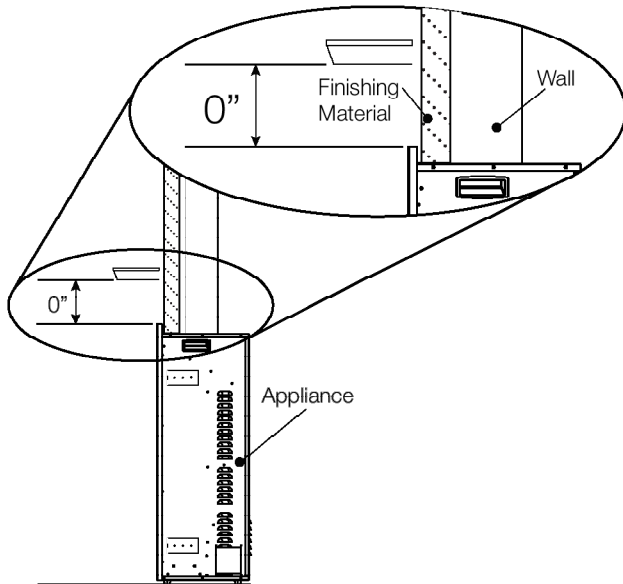

Unpacking & Testing Appliance

Carefully remove the appliance from the box. Prior to installing the appliance, remove all packaging material and test to make sure the appliance operates properly by plugging the power supply cord into a conveniently located 120V, 15 Amp minimum grounded outlet.

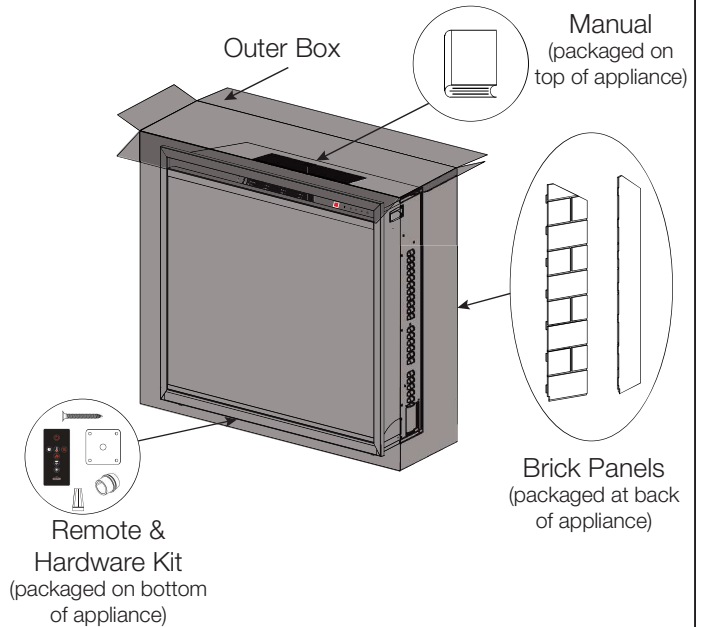

Optional Trim Kit (NEFB42H-BS-TRIM)

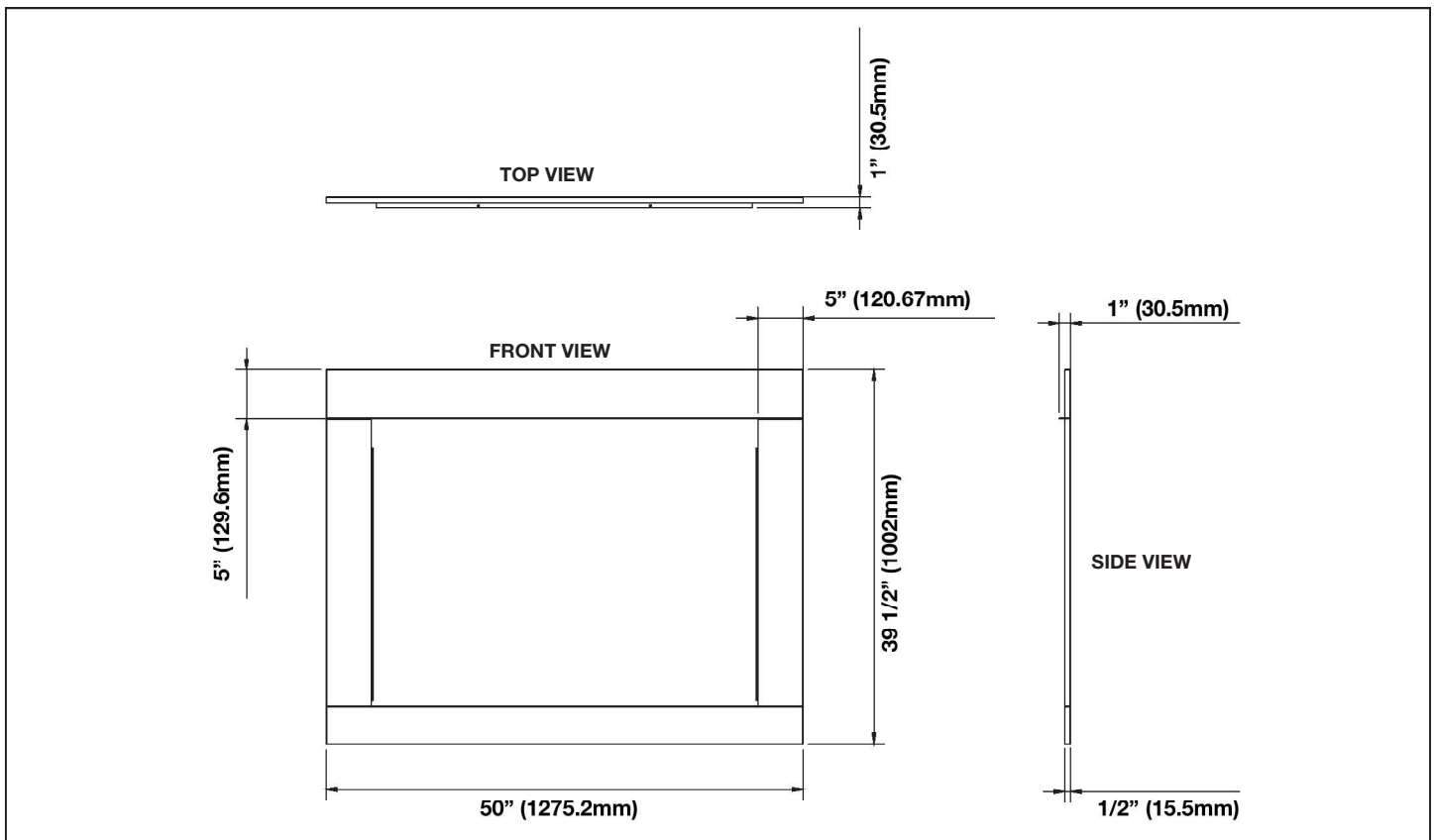

Spécifications

Modèle	BTU	Largeur		Hauteur		Profondeur		Dimensions de Vision
		Réel	Ossature	Réel	Ossature	Réel	Ossature	
NEFB42H-BS	5 000 / 10 000	42 1/8"	41 1/2"	31 7/8"	31 1/4"	14"	13 3/4"	39 7/8" x 25 7/8"

Dimensions

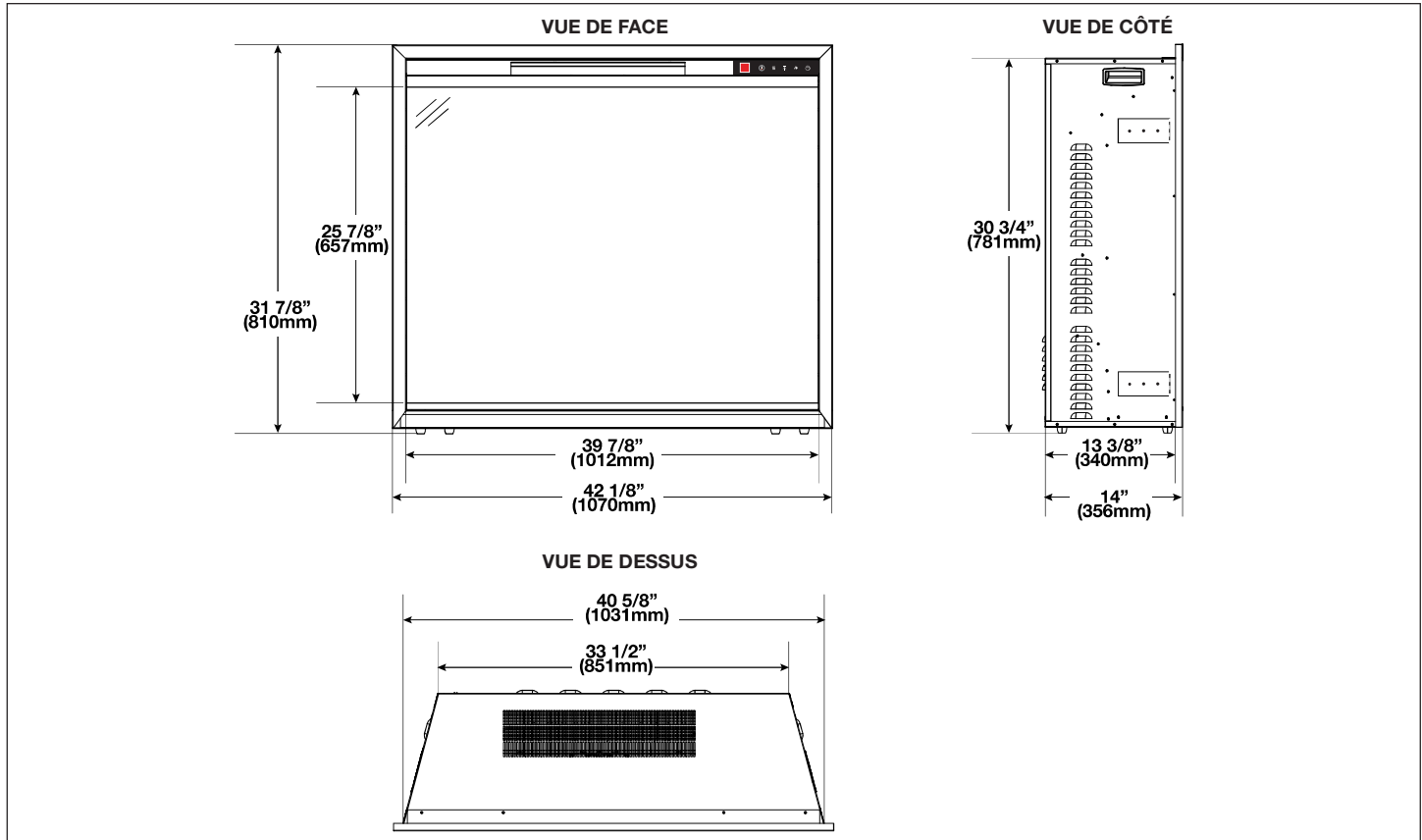

Ossature Approximatif

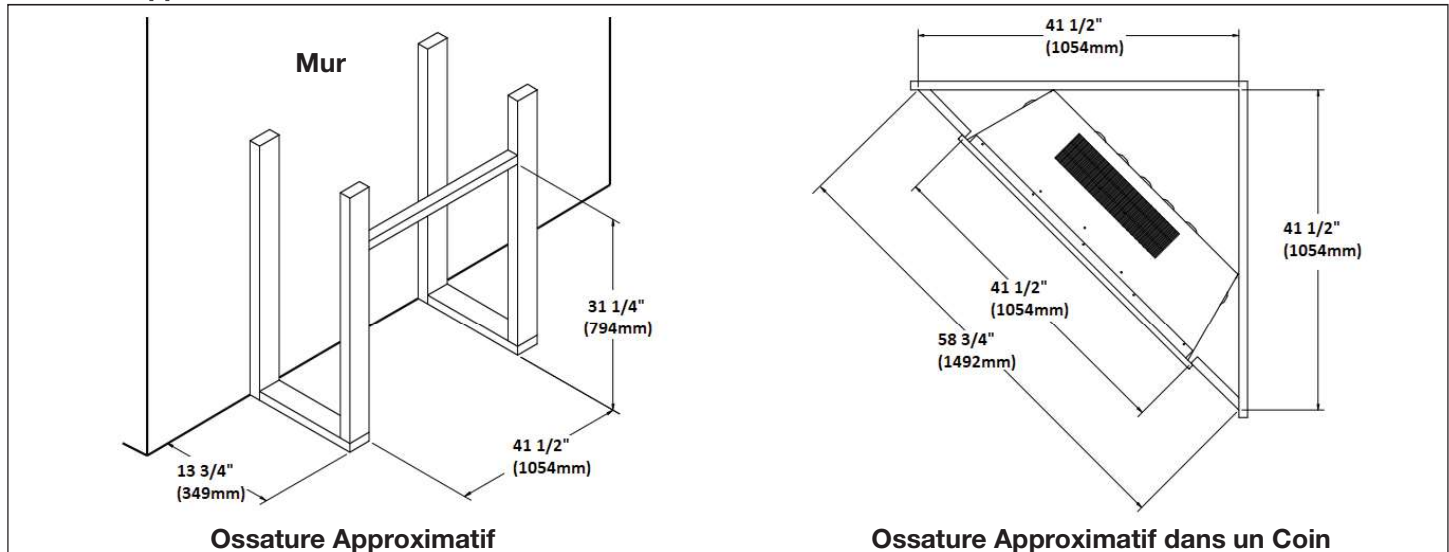

Information du produit fourni n'est pas complet et est sujet de changer sans préavis. Consultez le manuel d'installation pour information d'installation actuel.

Dégagements Minimaux à la Tablette

⚠ AVERTISSEMENT

- Lorsque vous utilisez de la peinture ou de la laque pour finir la tablette, la peinture ou la laque doit être résistante à la chaleur pour éviter la décoloration.

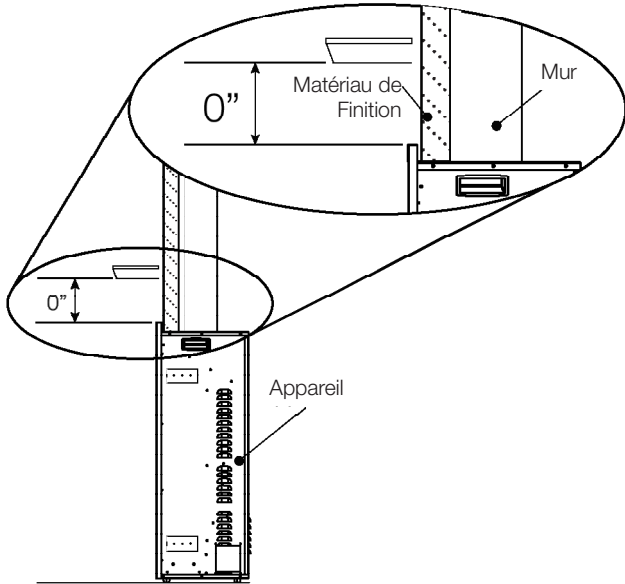

Déballage et Vérification d'Appareil

Retirez soigneusement l'appareil de la boîte et retirez les supports. Avant d'installer l'appareil, retirez tous les matériaux d'emballage et vérifiez que l'appareil fonctionne correctement en branchant le cordon d'alimentation dans une prise de terre minimale de 120V, 15 ampères, mise à la terre.

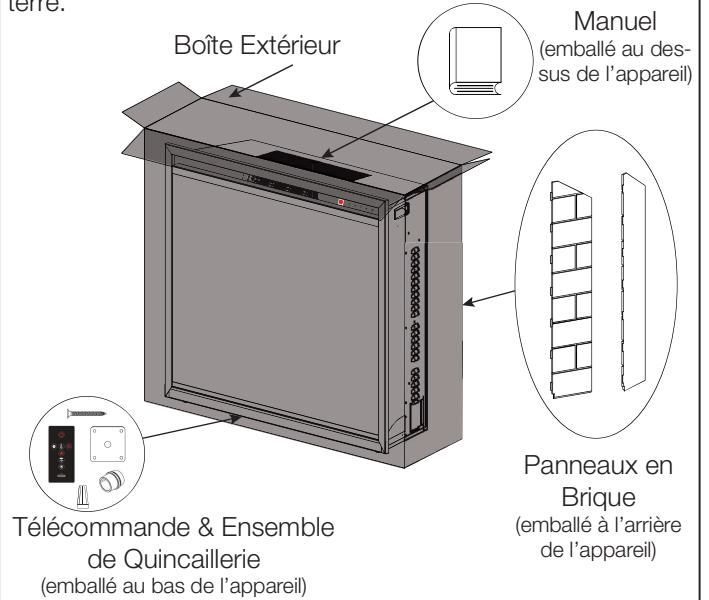

Optional Trim Kit (NEFB42H-BS-TRIM)

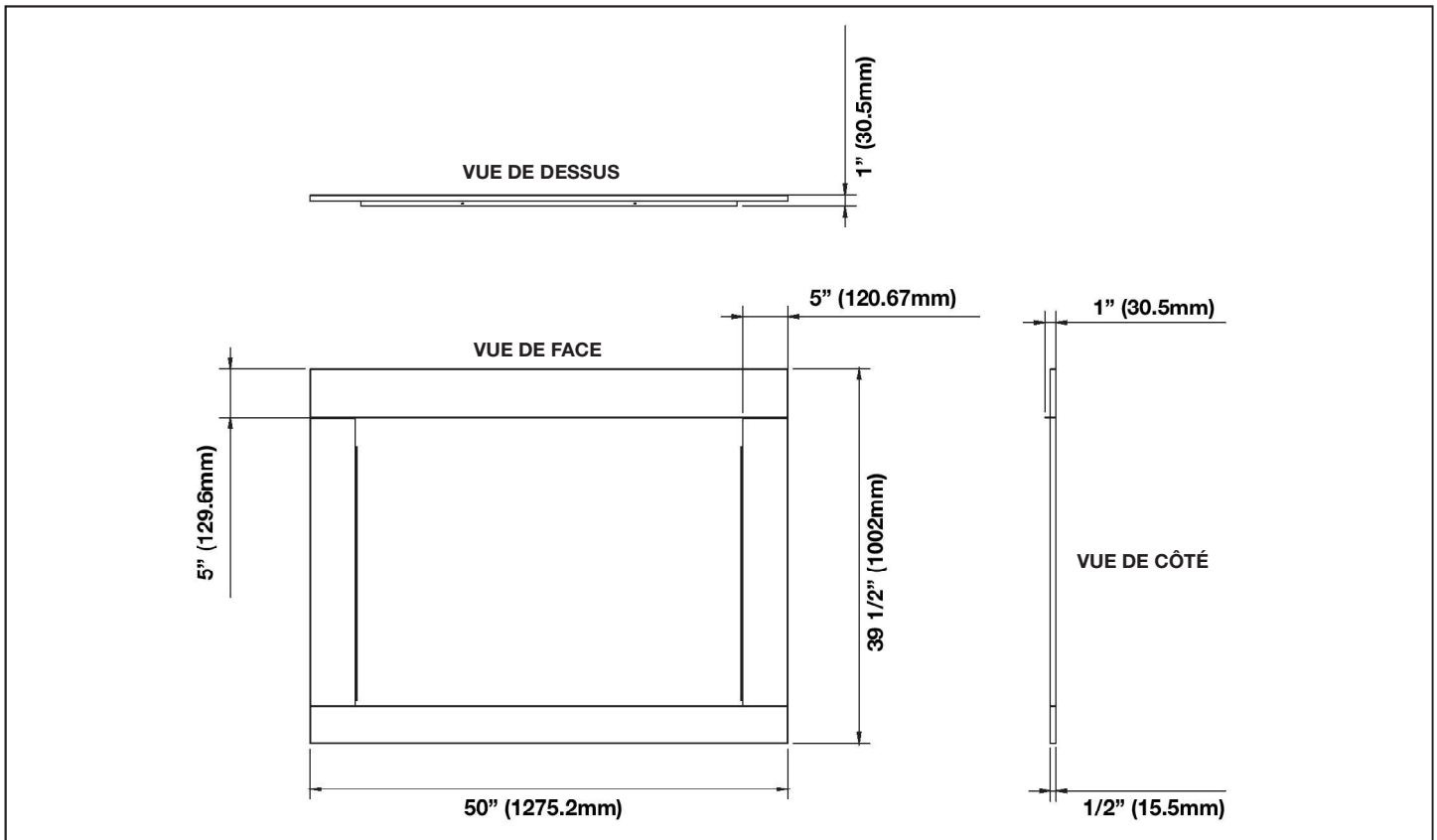

W415-3025 / 02.23.22