

FIG. A - PLAN VIEW CUT-OUT

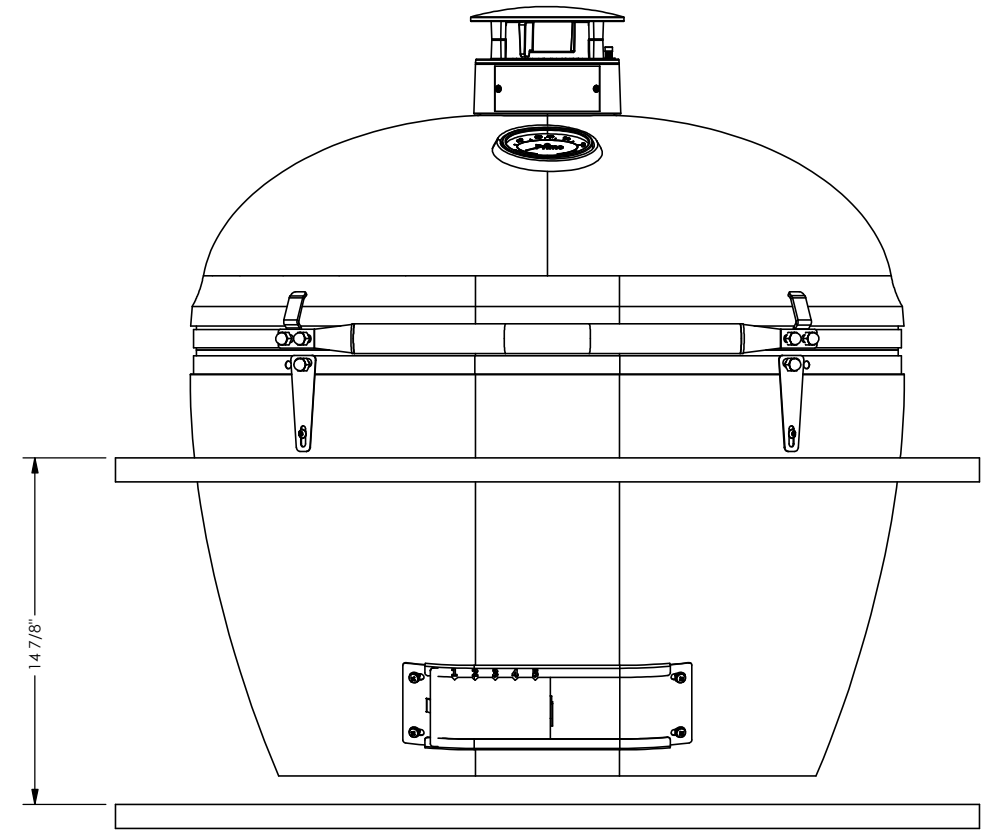

FIG. B - ELEVATION - HT. FROM TOP SURFACE TO SUPPORTING SHELF

PRELIMINARY

NOTES:
 -ALL DIMENSIONS ARE TO THE OUTSIDE OR OUTSIDE SHARP UNLESS OTHERWISE NOTED
 TOOLING REFERENCE #: N/A
 -PORTED BURNER PARTS ARE TO BE CUT WITH PUNCHES ONLY (NO LASER-CUT PORTS).
 -NO PUNCH SUBSTITUTIONS ALLOWED.

	A-000	INITIAL RELEASE	OZV	OZV	3/8/24	MAX. TOLERANCE UNLESS OTHERWISE SPECIFIED FRACTIONS: ±1/64" DECIMALS: ±.015 ROUND HOLE Øs (EXCEPT PORTS): ±.005 ROUND PORT Øs: ±.001 ANGLES: ±2° ALL BENDS 90°	MAT'L. -	DO NOT SCALE DRAWING	EMPIRE COMFORT SYSTEMS, INC
	A-000						DESCRIPTION: CUT-OUT XXL		
ECO NUMBER	LTR	REVISION	ENG	DRAFT	DATE		USED ON:	SHEET: 1 OF 1	NO. XXL CUT-OUT

OUT