

Greenfire® GF40-2



OWNER'S & INSTALLATION MANUAL

Freestanding Pellet Stove



French Manual: <https://bit.ly/2OaBzTR>
Manuel en Français : <https://bit.ly/2OaBzTR>

PLEASE READ THIS ENTIRE MANUAL BEFORE INSTALLATION AND USE OF THIS PELLET-BURNING ROOM HEATER. FAILURE TO FOLLOW THESE INSTRUCTIONS COULD RESULT IN PROPERTY DAMAGE, BODILY INJURY OR EVEN DEATH.

Contact your building or fire officials about restrictions and installation inspection requirements in your area.

WARNING:
Improper installation, adjustment, alteration, service or maintenance can cause injury, property damage, or loss of life. Refer to this manual. For assistance or additional information consult an authorized installer or service agency.

FOR YOUR SAFETY:
Do not store or use gasoline or other flammable vapours and liquids in the vicinity of this or any other appliance.
Installation and service must be performed by an authorized installer or service agency.

Tested by:



Installer: Please complete the details on the back cover and leave this manual with the homeowner.

Homeowner: Please keep these instructions for future reference.

TO THE NEW OWNER

Congratulations! You are the owner of a state-of-the-art Pellet Stove.
Thank you for purchasing a
FPI FIREPLACE PRODUCT.

The pride of workmanship that goes into each of our products will give you years of trouble-free enjoyment. Should you have any questions about your product that are not covered in this manual, please contact the GREENFIRE DEALER in your area.

Safety Note: If this stove is not properly installed, a house fire may result. For your safety, follow the installation instructions, contact local building, fire officials, or authority having jurisdiction about restrictions and installation inspection requirements in your area.

The authority having jurisdiction should be consulted before installation to determine the need to obtain a permit.

Emissions and Efficiency: This manual describes the installation and operation of the Enviro Mini pellet heater. This heater is U.S. ENVIRONMENTAL PROTECTION AGENCY Certified to comply with 2020 particulate emission standards. Under specific test conditions this heater has been shown to deliver heat at rates ranging from 6,881-23,892 Btu/hr.

Efficiency: 80.2%* HHV (PFS TECO 21-694)

*When using optional top vent adaptor kit (GF40-920) and 3" to 6" flue adaptor (3PVP-X6). See manual for further information.

WARNING: This pellet heater needs periodic inspection and repair for proper operation. It is against federal regulations to operate this pellet heater in a manner inconsistent with operating instructions in this manual.

WARNING: This wood pellet has a manufacturer set minimum low burn rate that must not be altered. It is against federal regulations to alter this setting or otherwise operate this pellet heater in a manner inconsistent with operating instructions in this manual.

FIRE EXTINGUISHER AND SMOKE DETECTION: All home with a pellet burning stove should have at least one fire extinguisher in a central location known to all the household. Smoke detectors and carbon monoxide detectors should be installed maintained in the room containing the stove. If it sounds the alarm, correct the cause but do not deactivate. You may choose to relocate the smoke the smoke detection device within the room; **DO NOT REMOVE THE SMOKE OR CARBON MONOXIDE DETECTORS FROM THE ROOM.**

WARNING: This wood heater needs periodic inspection and repair for proper operation. It is against federal regulation to operate this wood heater in a manner inconsistent with operating instructions in this manual.

WARNING: This wood heater has a manufacturer set minimum low burn rate that must not be altered. It is against federal regulations to alter this setting or other wise operate this wood heater in a manner inconsistent with operating instructions in this manual.



919-874

DIMENSIONS

Unit dimensions4

SAFETY LABEL

Copy of Serial No. Decal4

INSTALLATION

Introduction.....6
 Important Safety Information.....6
 Safety Warnings & Recommendations7
 Copy of the Safety Decal.....9
 Locating your pellet stove 10
 Unpacking and Removing Pellet Stove From Pallet. 10
 Clearances to Combustibles..... 12
 Alcove Clearances 13
 Vent Termination Requirements..... 14
 Exhaust and Intake Locations..... 15
 Mobile Home Installation 16
 Corner Through Wall Installation 16
 Horizontal Exhaust Through Wall Installation 17
 Through Wall Vertical Rise Horizontal Termination
 Installation - Freestanding 18
 Inside Vertical Installations 19
 Outside Vertical Installations 19
 Hearth Mount Installation 20
 Top Vent Adaptor Kit & 3" to 6" Flue Adaptor 21
 Thermostat Install 21

OPERATING INSTRUCTIONS

Control Board Functions.....23
 Automatic Safety Features23
 Operating Your Pellet Stove.....24
 Turning Your Pellet Stove Off.....24
 Damper Set-up.....25
 Guidelines for Fuel Quality25

MAINTENANCE

Routine Cleaning & Maintenance26
 Troubleshooting30
 Wiring Diagram33

PARTS

Parts List34
 Parts36

WARRANTY

Warranty38

4 | dimensions

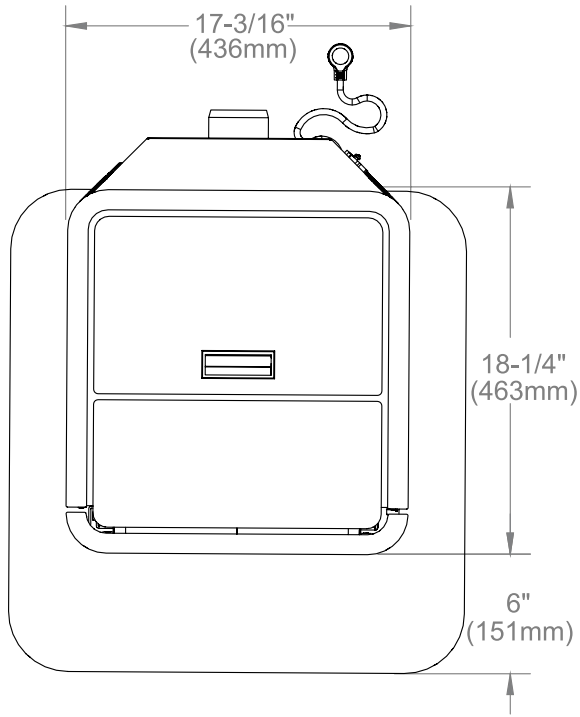

Weight (with full hopper): 280 lb (127 Kg)

Hopper Capacity: up to 67 lb (28 Kg)

Voltage: 110 - 120 V

Max Current: 4.1 Amps

Consumption on High: 3.1 lb/hr (1.4 Kg/hr)*

Consumption on Low: 1.3 lb/hr (0.6 Kg/hr)*

(Note: Consumption will vary with the type of fuel used.)

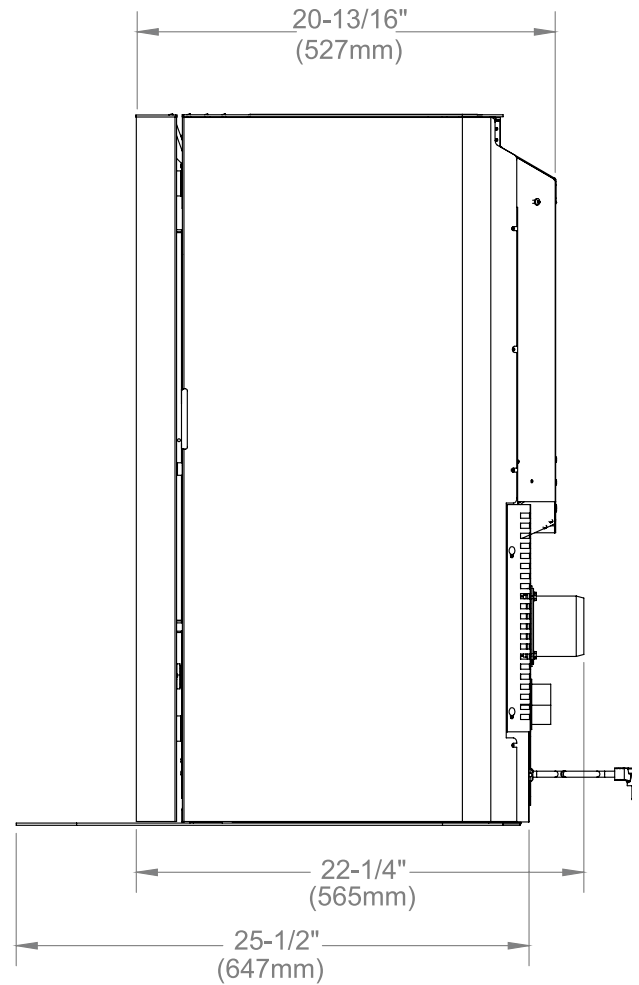
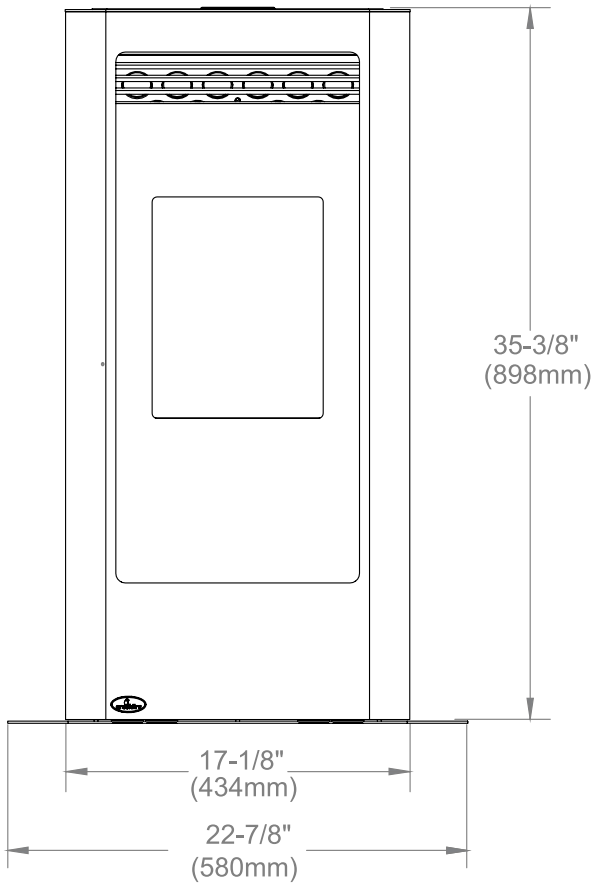

This is a copy of the safety label that accompanies each GF40 . We have printed a copy of the contents here for your reference.

On the GF40 the safety label is located on the underside of the hopper lid.

559

GREENFIRE MODEL / MODELE : GF40-2

Listed Room Heater, Pelletized Fuel Type Appareil de chauffage à granules certifié Suitable For Mobile Home Installation (Approuvé pour installation dans une maison mobile)

Certified to (certifié) ASTM E1509-12, UL C S627-00
 Refer to Intertek's Directory of Building Products for detailed information. / Reportez-vous à l'Annuaire des produits du bâtiment de Intertek pour obtenir des informations détaillées.

This pellet appliance has been tested and listed for use in manufactured homes in accordance with Oregon Administration Rules 814-23-900 through 814-23-909. Install and use only in accordance with the Manufacturer's installation and operating instructions. Contact local building or fire officials about restrictions and installation inspection in your area. Do not connect this unit to a chimney. Hire a certified chimney professional to install building codes and manufacturers instructions for precautions required for passing a chimney through a combustible wall or ceiling. Electrical rating: 120 volts, 60 Hz, 4.1 Amps. Route cord away from the heater.
 Cet appareil à granules a été testé et répertorié pour une utilisation dans les maisons préfabriquées conformément aux règlements du gouvernement de l'Oregon, de 814-23-900 à 814-23-909. Installer et utiliser uniquement conformément aux consignes d'installation et d'utilisation du fabricant. Contacter les autorités locales de la construction ou de la protection incendie pour s'informer sur les restrictions et l'inspection de l'installation au niveau local. Ne pas brancher cet appareil sur un conduit de cheminée, utilisé pour un autre appareil. Consulter les codes de construction locaux et les consignes du fabricant pour les précautions nécessaires à prendre pour faire passer une cheminée à travers un mur ou un plafond combustible. Puissance électrique : 120 volts, 60 Hz, 4,1 A. Maintenir le câble à l'écart de l'appareil de chauffage.

For Use With Only Pelletized Wood Fuels. Operate only with venting door and ash removal door closed. Only replace glass with ceramic glass. Components required for installation: a 3 inch (75 mm) or 4inch (100 mm) listed PL vent, complete with components. Hearth mount installations: a listed single wall chimney liner may be used. Inspect and clean Exhaust Venting system frequently.
 A utiliser avec des combustibles sous forme de granules uniquement. Faire fonctionner seulement avec la porte de ventilation et la porte de retrait des cendres complètement fermées. Remplacer seulement la vitre par une vitre en céramique. Composants requis pour l'installation : ventilation PL approuvée de 3 pouces (75 mm) ou 4 pouces (100 mm) avec pièces. Installations de montage de foyer, une doublure approuvée de cheminée à simple paroi peut être utilisée. Inspecter et nettoyer fréquemment le système d'évacuation. This wood heater needs periodic inspection and repair for proper operation. Consult the owner's manual for further information. It is against Federal regulations to operate this wood heater in a manner inconsistent with the operating instructions in the owner's manual. U.S. ENVIRONMENTAL PROTECTION AGENCY Certified to comply with 2020 particulate emission standards. Under specific test conditions this heater has been shown to have a particulate emission level of 54 g/hr. Ce poêle à granules doit être périodiquement inspecté et réparé pour un fonctionnement correct. Consulter le manuel d'utilisation pour plus d'information. Il est contraire à la réglementation fédérale de faire fonctionner ce poêle à granules non conforme aux consignes d'utilisation figurant dans le manuel. Ce poêle (réglé) aux normes 2020 en matière d'émissions de particules de l'Environmental Protection Agency, des États-Unis. Dans des conditions de test spécifiques, ce poêle a montré un niveau d'émission de particules de 0,54 g/h.

**DO NOT REMOVE THIS LABEL
 NE PAS ENLEVER CETTE ÉTIQUETTE**

OUTPUT Rating/Puissance de sortie : 6.881 to 23.892 BTU/Hr (2.01 to 7.00 kWh)

- LIGHTING INSTRUCTIONS:**
 - Press and release the on / off button
 - Once fire has started, set the heat output to the desired setting.
TO TURN THE UNIT OFF:
 - Push the on / off button
 (Refer to owners manual for detailed instructions)

CONSIGNES D'ALLUMAGE :

- Appuyer sur le bouton on/off (marche/arrêt), puis le relâcher.
 - Une fois que le feu a démarré, régler la sortie de chaleur au niveau désiré.
POUR ÉTEINDRE L'APPAREIL :
 - Appuyer sur le bouton on/off.
 (Se reporter au manuel d'utilisation pour des consignes détaillées.)

CAUTION:

Hot while operating. Do not touch, severe burns may result. Keep children, clothing, furniture, gasolene or other flammable vapors away.
 See installation and operating instructions accompanying appliance.



ATTENTION :

Appareil très chaud lorsqu'il est en marche. Ne pas toucher pour éviter de sévères brûlures. Tenir à distance les enfants, les vêtements, les meubles, l'essence ou autres fluides inflammables.
 Consulter le manuel d'installation et d'utilisation.

DATE OF MANUFACTURE / DATE DE FABRICATION : 2022 2023 2024
 J F M A M J J A S O N D

**INSTALLED AS A FREESTANDING STOVE MODEL (FS) /
 À INSTALLER COMME UN MODELE DE POÊLE AUTOPORTANT**

Minimum clearances to combustible materials, conventional or mobile home / Dégradements minimaux par rapport aux matériaux combustibles : maison conventionnelle ou mobile.

- A) Sidelwall to unit / Du mur latéral à l'appareil 8" (200 mm)
 B) Backwall to unit / Du mur du fond à l'appareil 5,5" (140 mm)
 C) Backwall to Chimney Connector / Du mur du fond au raccordement de cheminée 4" (100 mm)
 D) Corner to unit / Du coin à l'appareil 3" (75 mm)
 E) If supplied Hearth Pad is used no floor protection is required. If unit is installed on a combustible floor and the supplied Hearth Pad is not used the floor must be protected by a certified non-combustible Hearth Pad extending 6 inches (150 mm) in front of the glass. / Si le protecteur de plancher fourni est utilisé, aucune autre protection n'est requise. Si l'appareil est installé sur un plancher combustible et que le protecteur de plancher n'est pas utilisé, le plancher combustible doit être protégé par un matériel non combustible certifié s'étendant sur 6 pouces (150 mm) à l'avant de la vitre.

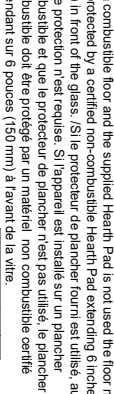

PFS TECO REPORT #21-694



Manufactured in Canada for / Fabriqué au Canada pour : FPI Fireplace Products International Ltd. Delta, BC, Canada
 Certified for use in Canada & USA / Certifié pour une installation au Canada et aux États-Unis. C-15927 920-411

Introduction

IMPORTANT SAFETY DATA:

Please read this entire Owner's Manual before installing or operating your Regency Pellet Stove. Failure to follow these instructions may result in property damage, bodily injury or even death. Any unauthorized modification of the appliance or use of replacement parts not recommended by the manufacturer is prohibited.

Contact your local building or fire official to obtain a permit and any information on installation restrictions and inspection requirements for your area. All local regulations, including those referring to national and European Standards need to be complied with when installing this appliance.

To prevent the possibility of a fire, ensure that the appliance is properly installed by adhering to the installation instructions. An Regency dealer will be happy to assist you in obtaining information with regards to your local building codes and installation restrictions.

The stove's exhaust system works with negative combustion chamber pressure and a slightly positive chimney pressure. It is very important to ensure that the exhaust system be sealed and airtight. The ash pan and viewing door must be locked securely for proper and safe operation of the pellet stove. Operating with door open could cause a fire inside the house as well as the release of carbon monoxide into the living space.

Carbon monoxide is a colorless and odorless gas, to prevent it from poisoning you or your family know the symptoms of carbon monoxide poisoning: headache, dizziness, weakness, sleepiness, nausea, vomiting, and confusion. Carbon monoxide reduces the blood's ability to carry oxygen. Low blood oxygen levels can result in loss of consciousness and death.

Do not burn with insufficient combustion air. A periodic check is recommended to ensure proper combustion air is admitted to the combustion chamber. Setting the proper combustion air is achieved by adjusting the slider damper located on the left side of the stove.

When installing the stove in a mobile home, it must be electrically grounded to the steel chassis of the home and bolted to the floor. Make sure that the structural integrity of the home is maintained and all construction meets local building codes.

Consider all large air moving devices when installing your unit and provide room air accordingly. NOTE: Extractor fans when operating in the same room or space as the appliance, may cause problems. Limited air for combustion may result in poor performance, smoking and other side effects of poor combustion.

Soot or creosote may accumulate when the stove is operated under incorrect conditions such as an extremely rich burn (black tipped, lazy orange flames).

Be sure to maintain the structural integrity of your home when passing a vent through walls, ceilings, or roofs. It is recommended that the unit be secured into its position in order to avoid any displacement. This appliance must be installed on a floor with an adequate load bearing capacity. If an existing construction doesn't meet these prerequisite, suitable measures (e.g. load distributing plate) shall be taken to achieve it.

FRESH AIR: Outside Fresh Air connection is optional. Fresh Air must be connected to all units installed in Mobile Homes and Air Tight Homes (R2000) or where required by local codes.

If you have any questions with regards to your stove or the above-mentioned information, please feel free to contact your local dealer for further clarification and comments.

SAFETY WARNINGS AND RECOMMENDATIONS:

Caution: Do not connect to any air distribution duct or system. Do not burn garbage or flammable fluids such as gasoline, naphtha or engine oil. Unit hot while in operation. Keep children, clothing and furniture away. Contact may cause skin burns.

Warning: Parts of the appliance, especially the external surfaces, will be hot to touch when in operation and due care will need to be taken. Never place wood, paper, furniture, drapes or other combustible materials within 80cm (31½") of the front of the unit, 20cm (7") from each side, and 10cm (4") from the back of the unit. Do not let children or pets touch it when it is hot.

To prevent the possibility of a fire, ensure that the appliance is properly installed by adhering to the installation instructions. An Regency dealer will be happy to assist you in obtaining information with regards to your local building codes and installation restrictions.

FIRE EXTINGUISHER AND SMOKE DETECTION: All homes with a pellet burning stove should have at least one fire extinguisher in a central location known to all in the household. Smoke detectors should be installed and maintained in the room containing the stove when installing and operating a pellet burning appliance. If it sounds the alarm, correct the cause but do not deactivate. You may choose to relocate the smoke detection device within the room; DO NOT REMOVE THE SMOKE DETECTOR FROM THE ROOM.

CHIMNEY OR RUN AWAY FIRE: Call local fire department (or dial 911). Close the draft fully. Examine the flue pipes, chimney, attic, and roof of the house, to see if any part has become hot enough to catch fire. If necessary, spray with fire extinguisher or water from the garden hose. IMPORTANT: Do not operate the stove again until you are certain the chimney and its lining have not been damaged.

FUEL: This pellet stove is designed and approved to only burn wood pellet fuel with up to 3% ash content. Dirty fuel will adversely affect the operation and performance of the unit and may void the warranty. Check with your dealer for fuel recommendations.

THE USE OF CORD WOOD IS PROHIBITED BY LAW.

SOOT and FLYASH: Formation and Need for Removal - The products of combustion will contain small particles of flyash. The flyash will collect in the exhaust venting system and restrict the flow of flue gases. Incomplete combustion, such as occurs during startup, shutdown, or incorrect operation of the room heater will lead to some soot formation which will collect in the exhaust venting system. The exhaust venting system should be inspected at least once every year to determine if cleaning is necessary.

CREOSOTE: When wood is slowly burned it produces tar and other organic vapours and these combine with expelled moisture to form creosote. The creosote vapours condense in the relatively cool chimney flue associated with a slow burning fire. As a result, creosote residue accumulates on the flue lining. When ignited this creosote can result in an extremely hot chimney fire.

CLEANING: There will be some build up of fly ash and small amounts of creosote in the exhaust. This will vary due to the ash content of the fuel used and the operation of the stove. It is advisable to inspect and clean the exhaust vent semi-annually or every two tons of pellets.

ASHES: Disposed ashes should be placed in a metal container with a tight fitting lid. The closed container of ashes should be on a non-combustible floor on the ground, well away from all combustible materials pending final disposal. If the ashes are disposed of by burial in soil or otherwise locally dispensed, they should be retained in the closed container until all cinders have been thoroughly cooled.

ELECTRICAL: The use of a surge protected power bar is highly recommended. The unit must be grounded. The grounded electrical cord should be connected to a standard 110-120 volts, nominal average 2.0 Amps (4.1 Amps peak), and 60 hertz electrical outlet also must be accessible. Ensure the polarity to the outlet the unit will be plugged into is correct as incorrect polarity can affect the unit's operation. If this power cord should become damaged, a replacement power cord must be purchased from the manufacturer or a qualified Regency dealer. Be careful that the electrical cord is not trapped under the appliance and that it is clear of any hot surfaces or sharp edges. This unit's maximum power requirement is 184 watts (600 watts peak).

GLASS: Do not abuse the glass by striking or slamming the door. Do not attempt to operate the stove with broken glass. The stove uses ceramic glass. Replacement glass must be purchased from an Regency dealer. Do not attempt to open the door and clean the glass while the unit is in operation or if glass is hot. To clean the glass, use a soft cotton cloth and mild window cleaner, gas or wood stove glass cleaner, or take a damp paper towel and dip into the fly ash. This is a very mild abrasive and will not damage the glass.

FLAMMABLE LIQUIDS: Never use gasoline, gasoline-type lantern fuel, kerosene, charcoal lighter fluid, or similar liquids to start or "freshen up" a fire in the heater. Keep all such liquids well away from the heater while it is in use.

SMOKE DETECTOR: Smoke detectors should be installed and maintained in the structure when installing and operating a pellet burning appliance.

OPERATION: The ash pan and door must be closed securely for proper and safe operation of the pellet stove. Also ensure all gaskets on the door are checked and replaced when necessary.

KEEP ASH PAN FREE OF RAW FUEL.

Do not lace unburned fuel or new fuel in ash pan. A fire in the ash pan may occur.

INSTALLATION: Be sure to maintain the structural integrity of your home when passing a vent through walls, ceilings, or roofs. It is recommended that the unit be secured into its position in order to avoid any displacement.

DO NOT INSTALL A FLUE DAMPER IN THE EXHAUST VENTING SYSTEM OF THIS UNIT.

DO NOT CONNECT THIS UNIT TO A CHIMNEY FLUE SERVING ANOTHER APPLIANCE.

FRESH AIR: Outside Fresh Air connection is optional. Must be connected to all units installed in Mobile and "Air Tight Homes" (R2000) or where required by local codes. Consider all large air moving devices when installing your unit and provide fresh air accordingly. Limited air for combustion may result in poor performance, smoking and other side effects of poor combustion.

If you have any questions with regards to your stove or the above-mentioned information, please feel free to contact your local dealer for further clarification and comments.

FPI HAS NO CONTROL OVER THE INSTALLATION OF YOUR STOVE, FPI GRANTS NO WARRANTY IMPLIED OR STATED FOR THE INSTALLATION OR MAINTENANCE OF YOUR STOVE. THEREFORE, FPI ASSUMES NO RESPONSIBILITY FOR ANY CONSEQUENTIAL DAMAGE(S).

SAVE THIS INSTRUCTION MANUAL FOR FUTURE REFERENCE

DECIDING WHERE TO LOCATE YOUR PELLET APPLIANCE

1. Check the "Clearances to Combustibles" section for proper spacing.
2. Do not obtain combustion air from an attic, garage or any unventilated space. Combustion air may be obtained from a ventilated crawl space.
3. Do not install the stove in a bedroom.
4. You can vent the stove through an exterior wall behind the unit or connect it to an existing masonry or metal wood stove chimney (must be lined if the chimney is over 6" (15 cm) diameter, or over 28 inches² (180 cm²) cross sectional area). An interior vent can be used with approved pipe passing through the ceiling and roof.
5. Locate the stove in a large and open room that is centrally located in the house. This will optimize heat circulation.
6. The power cord is 8 feet (2.43 m) long and may require a grounded extension cord to reach the nearest electrical outlet. The use of a surge protected power bar is highly recommended.
7. Stove must sit on a non-combustible pad that extends six inches in front of the door or the included hearth pad (GF40-025).



REMOVING YOUR PELLET STOVE FROM THE CRATE

1. Start by removing the crating and unit bag, you will need a pry bar and hammer to remove the crating. A sawzall can be used to remove the crating by cutting the staples.
2. Open or Remove the outer door for easy access to screws securing unit to pallet.
3. Loosen/remove six T-20 screws securing Back Grill, once loose slide downwards and remove.
4. Use a 7/16 wrench or socket to remove the three shipping bolts holding the unit to the pallet, see Figure 1.
5. Brackets used to hold down the front of the stove can be recycled once removed.

Tools Required:

- T-20 Screwdriver or Drill Bit
- 7/16" Wrench or Socket

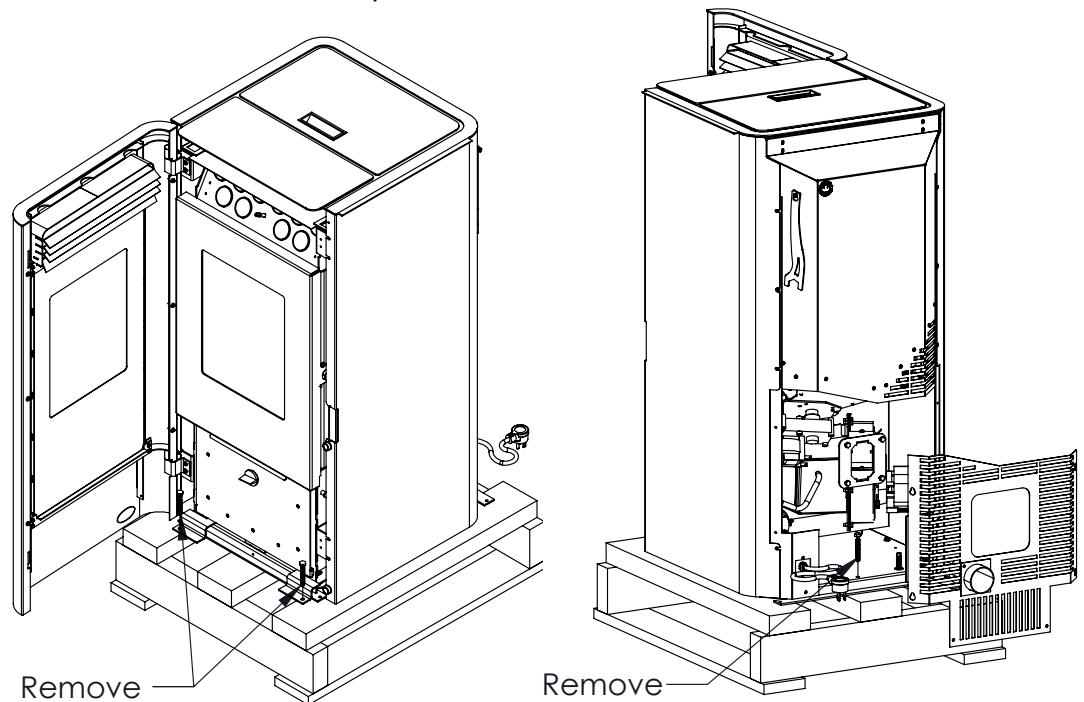

Figure 1: Shipping Bolt Removal

HEARTH INSTALLATION

IMPORTANT: Attach the supplied Hearth Pad (Part# GF40-025) when installing the unit on a combustible floor. The supplied hearth pad meets all the requirement of a proper hearth pad. If you do not use the supplied hearth pad a type 1 hearth pad must be used when on combustible material. A certified non combustible Hearth Pad with a minimum R Value of at least 0.84 must be placed underneath the unit and extend six inches in front of the unit measured from the glass. If the GF40 is installed on carpet the use of a solid non combustible Hearth Pad must be used under leveling legs.

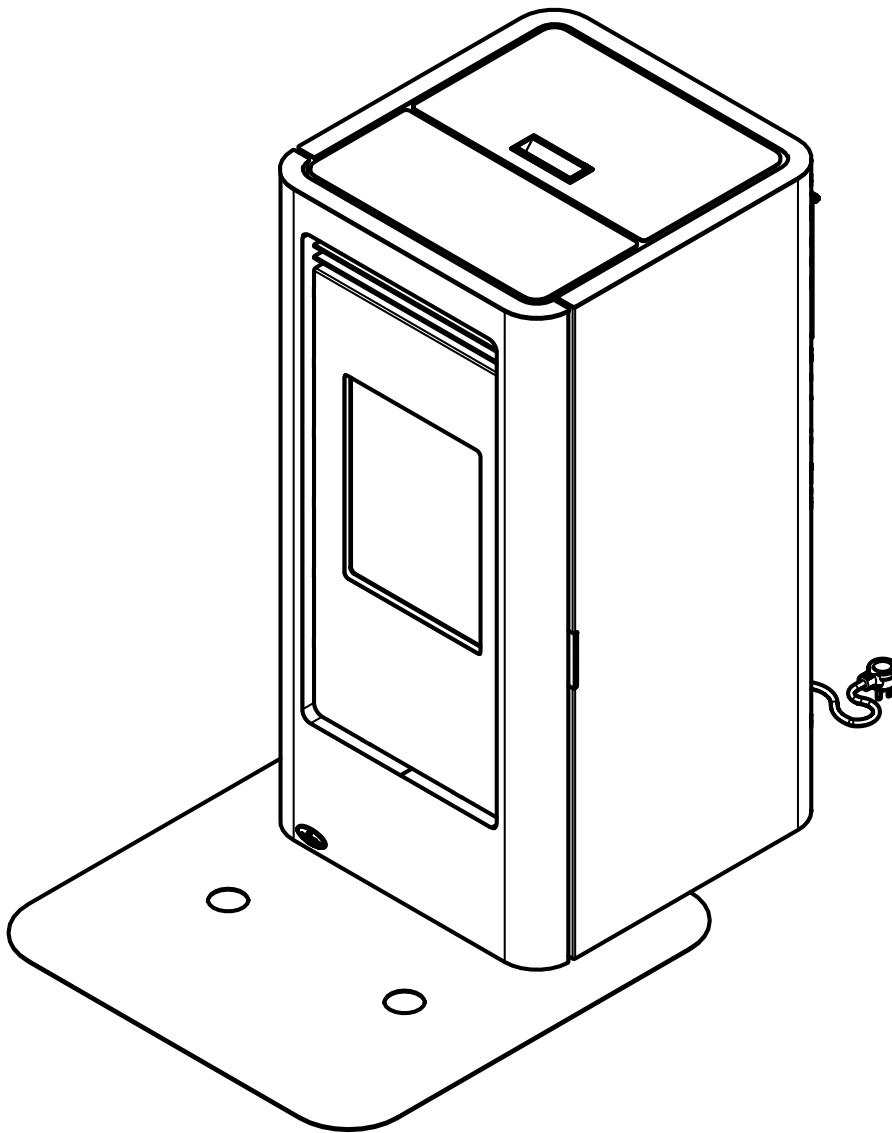

Figure 2: Hearth Pad Install

CLEARANCES TO COMBUSTIBLES

These dimensions are minimum clearances but it is recommended that you ensure sufficient room for servicing, routine cleaning and maintenance.

Note: This clearance is also required for air space between the appliance and wall/ceiling.

Clearances to combustibles are for the safety of the property. To avoid overheating and damaging the appliance these clearances should be maintained for non-combustibles also.

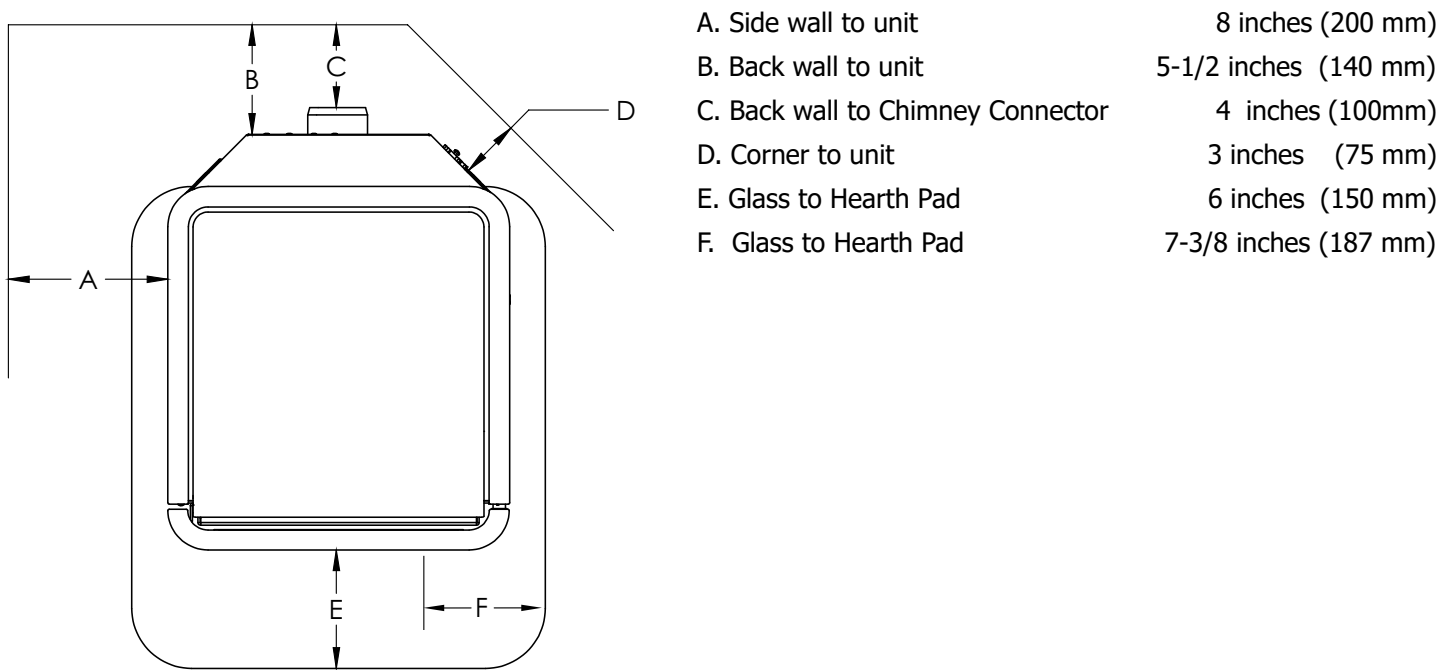

Figure 3: Minimum Install Clearances

ALCOVE CLEARANCES:

The unit may be installed in an alcove if desired. These minimum clearances to combustibles must be maintained at all times. Be sure to leave room for servicing, routine cleaning, and maintenance. These are inside dimensions.

Minimum Alcove Width	36 inches (915 mm)
Minimum Alcove Height	48 inches (1220 mm)
Minimum Alcove Depth	30 inches (762 mm)

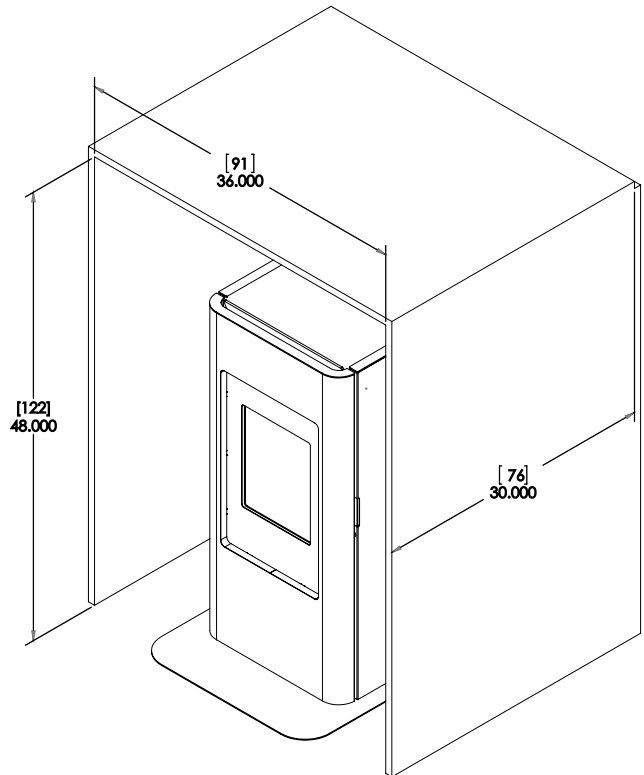

Figure 4: Minimum Alcove Clearances

VENT TERMINATION REQUIREMENTS

IT IS HIGHLY RECOMMENDED THAT YOUR PELLET STOVE BE INSTALLED BY AN AUTHORIZED DEALER/INSTALLER.

Table 1: Use in conjunction with Figure 6 for allowable exterior vent termination locations.

Letter	Minimum Clearance	Description
A	24 in (61 cm)	Above grass, top of plants, wood, or any other combustible materials.
B	48 in (122 cm)	Beside/below any door or window that may be opened. (18" (46 cm) if outside fresh air installed.)
C	12 in (30 cm)	Above any door or window that may be opened. (9" (23 cm) if outside fresh air installed.)
D	24 in (61 cm)	To any adjacent building, fences and protruding parts of the structure.
E	24 in (61 cm)	Below any eave or roof overhang
F	12 in (30 cm)	To outside corner.
G	12 in (30 cm)	To inside corner, combustible wall (vertical and horizontal terminations).
H	3 ft (91 cm) within a height of 15 ft (4.5 m) above the meter/regulator assembly	To each side of center line extended above natural gas or propane meter/regulator assembly or mechanical vent.
I	3 ft (91 cm)	From any forced air intake of other appliance
J	12 in (30 cm)	Clearance to non-mechanical air supply inlet to building, or the combustion air inlet to any appliance.
K	24 in (61 cm)	Clearance above roof line for vertical terminations.
L	7 ft (2.13 m)	Clearance above paved sidewalk or paved driveway located on public property.

- Do not terminate the vent in any enclosed or semi-enclosed areas such as a carport, garage, attic, crawlspace, narrow walkway, closely fenced area, under a sun deck or porch, or any location that can build up a concentration of fumes such as stairwells, covered breezeway, etc.

- Vent surfaces can become hot enough to cause burns if touched by children. Non-combustible shielding or guards may be required.

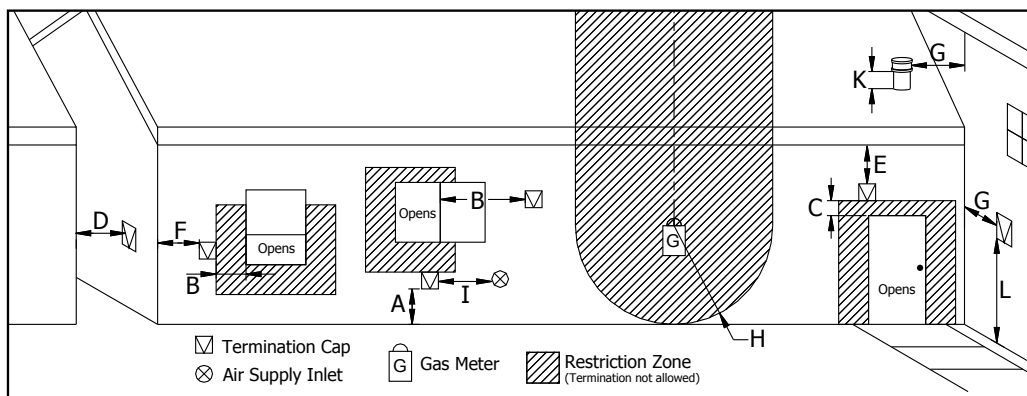

Figure 5: Use in conjunction with Table 1 for allowable exterior vent termination locations.

- Termination must exhaust above the inlet elevation. It is recommended that at least five feet of vertical pipe be installed outside when the appliance is vented directly through a wall, to create some natural draft to prevent the possibility of smoke or odor during appliance shut down or power failure. This will keep exhaust from causing a nuisance or hazard from exposing people or shrubs to high temperatures. In any case, the safest and preferred venting method is to extend the vent through the roof vertically.
- Distance from the bottom of the termination and grade is 12" (30 cm) minimum. This is conditional upon the plants and nature of grade surface. The exhaust gases are hot enough to ignite grass, plants and shrubs located in the vicinity of termination. The grade surface must not be lawn.
- If the unit is incorrectly vented or the air to fuel mixture is out of balance, a slight discoloration of the exterior of the house might occur. Since these factors are beyond the control of FPI, we grant no guarantee against such incidents.

NOTE: Venting terminals shall not be recessed into walls or siding.

OUTSIDE FRESH AIR CONNECTION

Outside fresh air is mandatory when installing this unit in airtight homes (R2000) and mobile homes.

A Fresh-air intake is strongly recommended for all installations. Failure to install a fresh air intake may result in improper combustion as well as the unit smoking during power failures.

When connecting to an outside fresh air source, do not use plastic or combustible pipe. A 2" minimum (51 mm) ID (inside diameter) steel, aluminum or copper pipe should be used. It is recommended, when you are installing a fresh air system, to keep the number of bends in the pipe to a minimum.

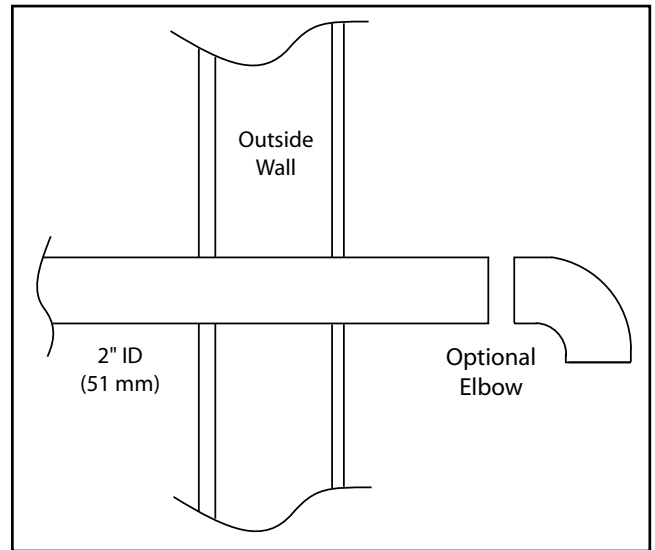

Figure 6: Outside Air Connection

EXHAUST AND INTAKE LOCATIONS

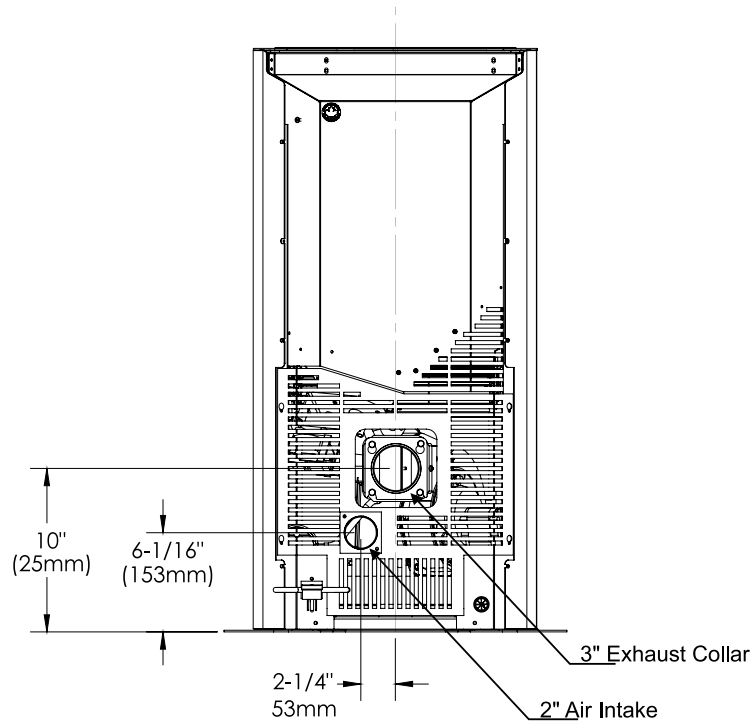

Figure 7: GF40 Inlet and Outlet Location

EXHAUST

Base of unit to center of flue	10 in (251 mm)
Center of unit to center of flue	0 in (0 mm) [at center of unit]

FRESH AIR INTAKE

Base of unit to center of intake	6 in (153 mm)
Center of unit to center of intake	2-1/4 in (53 mm)

IMPORTANT: When attaching the exhaust venting system to the unit or when joining vent sections three screws must be used at each joint. If vented horizontally, joints shall be made gas tight with aluminum foil duct tape. Heights may change if leveling legs are adjusted.

MOBILE HOME INSTALLATION

- Secure the heater to the floor using the two holes in the base.
- Ensure the unit is electrically grounded to the chassis of your home (permanently).
- Do not install in a room people sleep in.
- Outside fresh air is mandatory. Secure outside air connections directly to fresh air intake pipe and secure with three screws evenly spaced.

CAUTION: THE STRUCTURAL INTEGRITY OF THE MANUFACTURED HOME FLOOR, WALL AND CEILING/ROOF MUST BE MAINTAINED.

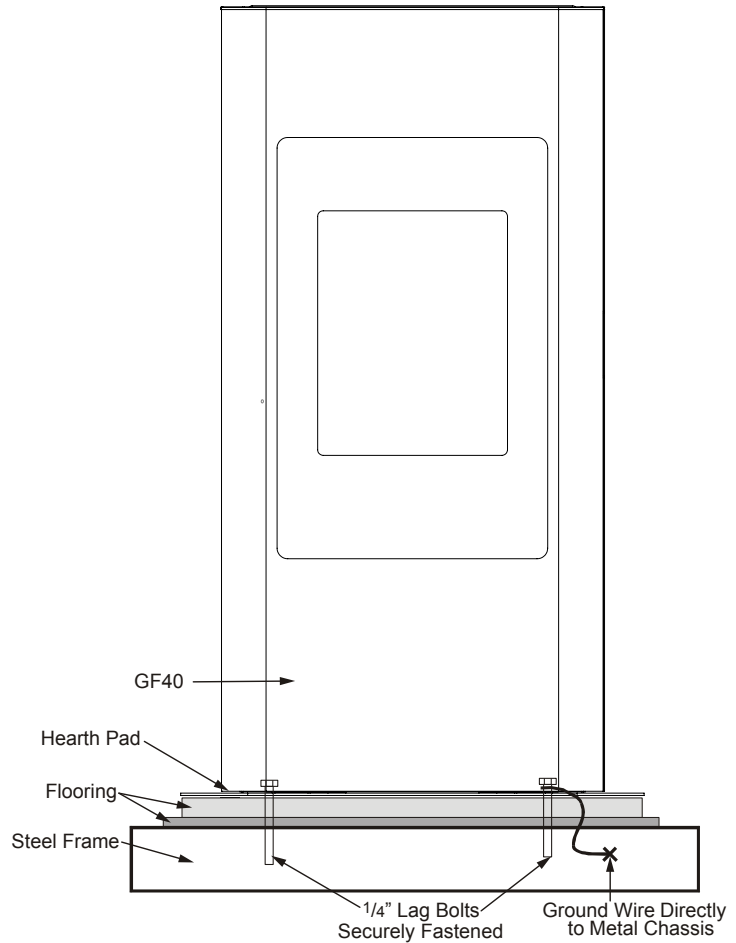

Figure 8: Mobile Home Installation

CORNER THROUGH WALL INSTALLATION:

Minimum clearances must be maintained for a corner installation as shown in figure 9.

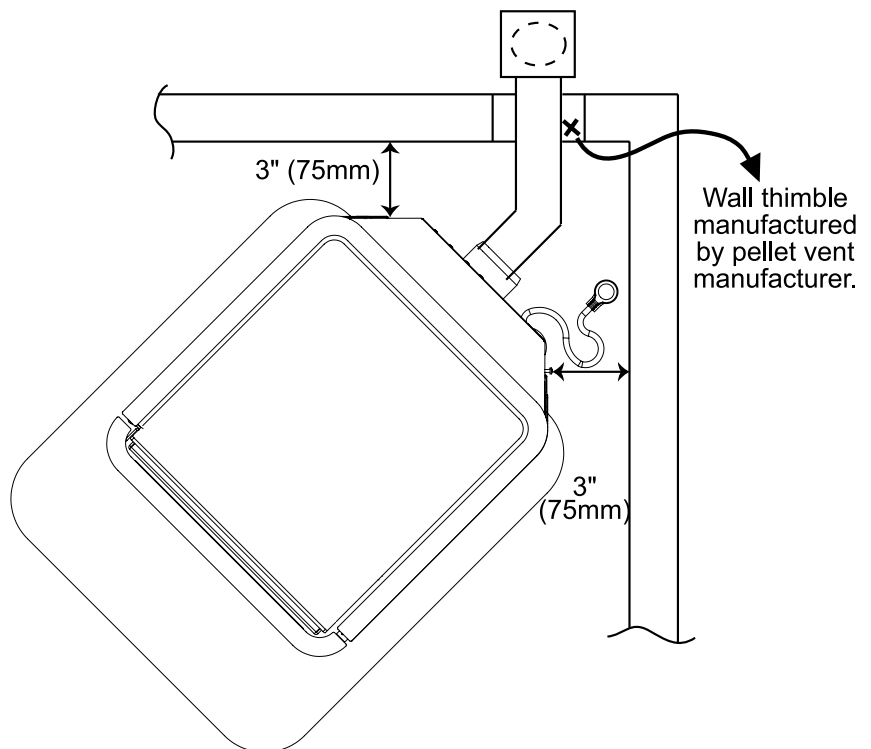

Figure 9: Corner Installation

HORIZONTAL EXHAUST THROUGH WALL INSTALLATION

Vent installation: install vent at clearances specified by the vent manufacturer.

A chimney connector shall not pass through an attic or roof space, closet or similar concealed spaces, or a floor, or ceiling. Where passage through a wall or partition of combustible construction is desired, the installation shall conform to CAN/CSA-B365 Installation Code for Solid-Fuel-Burning Appliances and Equipment. Only use venting of L or PL type with an inside diameter of 3 or 4 inches (7.6 or 10.1 cm).

1. Choose a location for your stove that meets the requirements stated in this manual and allows installation with the least amount of interference to house framing, plumbing, wiring, etc.
2. Install a non-combustible hearth pad (where necessary).

3. Place the appliance 15" (37.5 cm) away from the wall. If the stove is to be set on a hearth pad, set the unit on it, and adjust the leveling legs.

4. Locate the center of the exhaust pipe on the stove. Extend that line to the wall. Once you have located the center point on the wall, refer to pellet vent manufacturer installation instructions for correct hole size and clearance to combustibles.

5. Install the wall thimble as per the instructions written on the thimble. Maintain an effective vapour barrier in accordance with local building codes.

6. Install a length of 3" (75 mm) or 4" (100 mm) vent pipe into the wall thimble. The pipe should install easily into the thimble.

7. Connect the exhaust vent pipe to the exhaust pipe on the stove. Seal the connection with high temperature silicone.

8. Push the stove straight back, leaving a minimum of 5.5" (14 cm) clearance from the back of the stove to the wall. Seal the vent pipe to the thimble with high temperature silicone.

9. The pipe must extend at least 12" (30 cm) away from the building. If necessary, bring another length of pipe (PL type) to the outside of the home to connect to the first section. Do not forget to place high temperature silicone around the pipe that passes through the thimble.

** Note :A termination cap is highly recommended however to keep rodents, small animals, etc away as this can be easily accessed with simply having a 45 degree elbow in place.

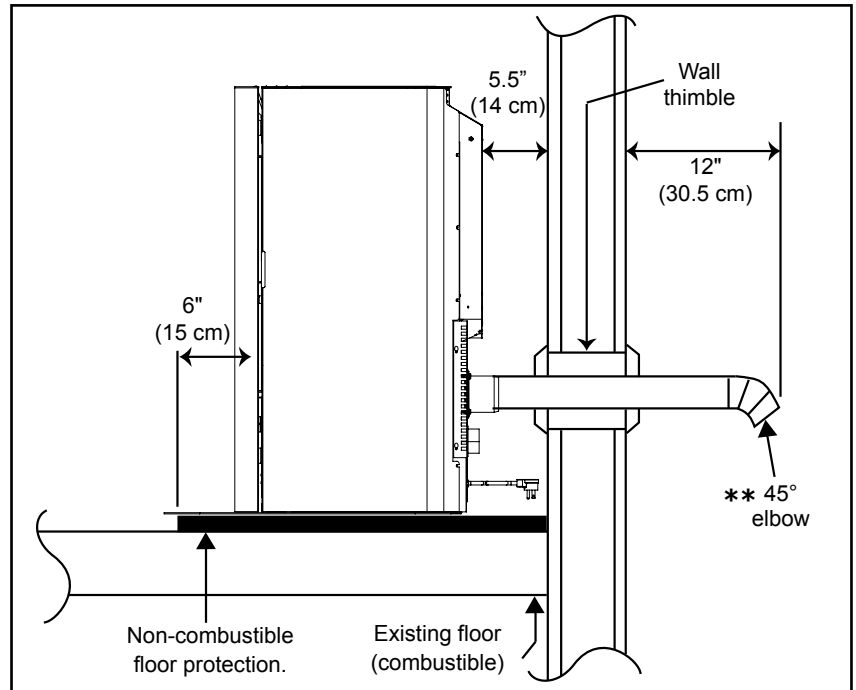

Figure 10: Straight through Wall Installation

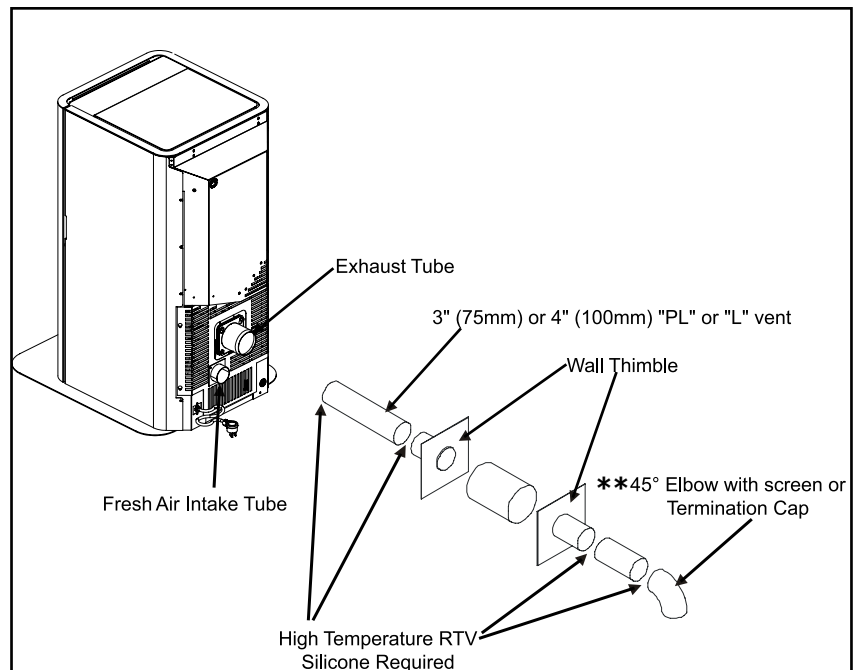

Figure 11: Venting to use with Straight through Wall Installation

10. Install a vertical pipe, or if all requirements for direct venting are met, install vent termination. The stainless steel cap termination manufactured by the vent manufacturer is recommended. However, when the vent terminates several feet above ground level and there are no trees, plants, etc. within several feet, a 45° elbow can be used as termination. The elbow must be turned down to prevent rain from entering.

NOTE:

- It is recommended that horizontal through wall installations have 3 to 5 feet (91 to 152 cm) of vertical pipe in the system to help naturally draft the unit in the event of extreme weather or a power outage.
- Some horizontal through wall installations may require a "T" and 3 to 5 feet (91 to 152 cm) of vertical pipe outside the building to help draft the unit. This may be required if a proper burn cannot be maintained, after the stove has been tested and the airflow set. This is due to the back pressure in the exhaust caused by airflow around the structure.
- Follow vent manufacturer guidelines for installation of venting. High temp sealant must be used when connecting vent pipe to the unit's starter pipe. Improper seals at the vent joints may cause combustion by-products to leak into the room where installed - **seal as required.**

THROUGH WALL VERTICAL RISE HORIZONTAL TERMINATION INSTALLATION - FREESTANDING:

A termination cap is always recommended for this type of install but a stainless steel termination hood or a 45° elbow may be used in place of the cap.

Figure 12 is the recommended installation set up, venting length is negligible.

Figure 13 is the installation to use if there is a concrete or retaining wall in line with exhaust vent on a pellet stove. The termination must be 12" (30 cm) from the outside wall and 12" (30 cm) above the ground.

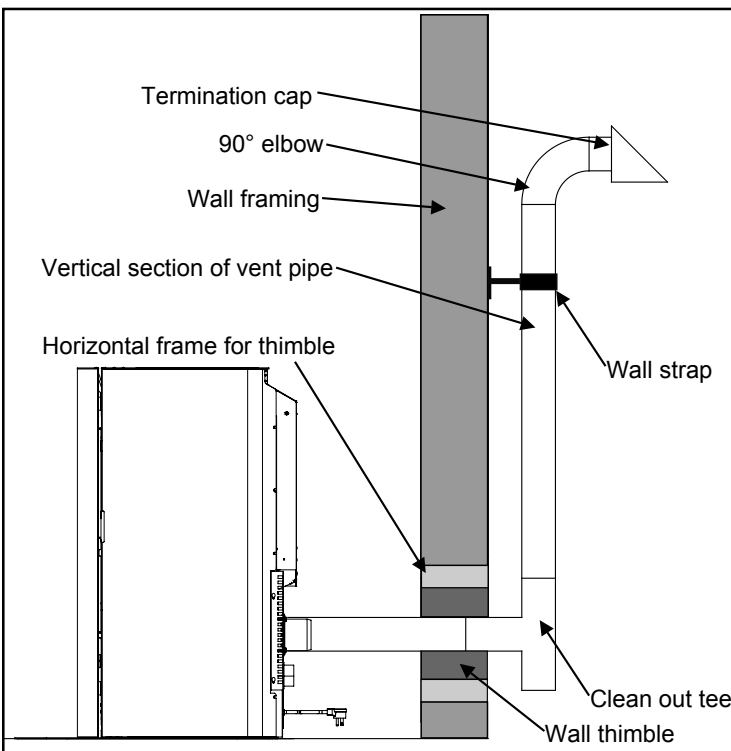

Figure 12: Venting Horizontally with Rise

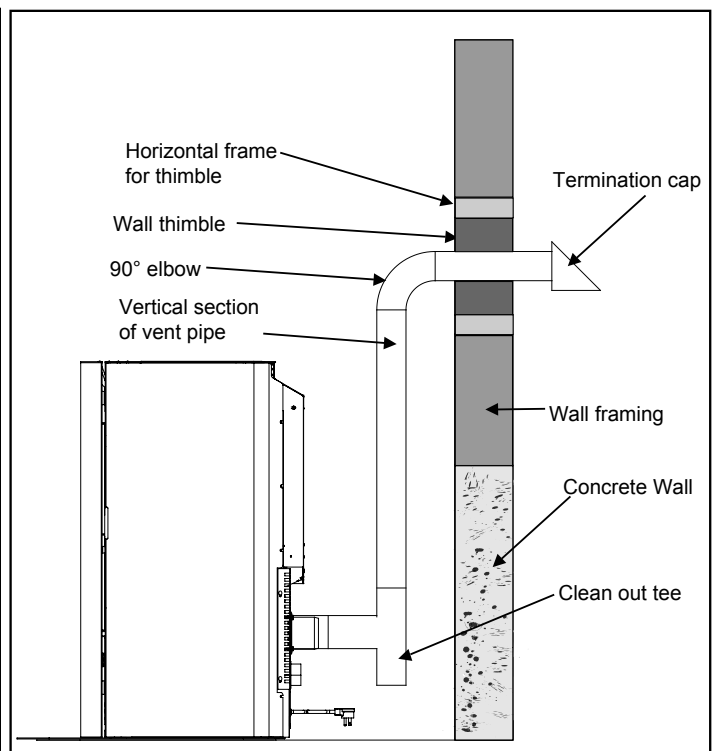

Figure 13: Venting with Concrete Wall Behind Unit

INSIDE VERTICAL INSTALLATIONS

To accomplish an outside vertical pipe installation, follow steps 1 through 5 in the "INSIDE VERTICAL INSTALLATIONS - FREESTANDING" section and then finish it by performing the following (refer to Figure 15).

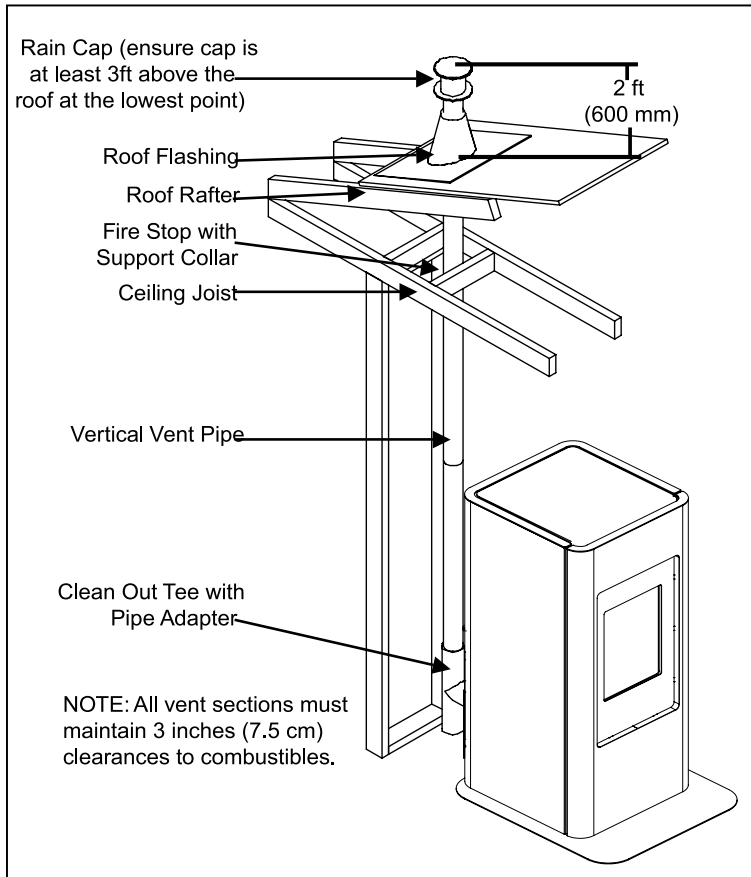

Figure 14: Inside Vertical Installation

1. Choose a stove location that is ideal. See the section "DECIDING WHERE TO LOCATE YOUR PELLET APPLIANCE."
2. Place a non-combustible hearth pad where necessary.
3. Place the unit on the hearth pad (if installed on a combustible surface) and space the unit in a manner so when the pellet vent is installed vertically, it will be 3" (7.5 cm) away from a combustible wall.
4. Install the tee with clean out.
5. Install the pellet vent upward from there. When you reach the ceiling, make sure that the vent goes through the ceiling fire stop. Maintain a 3" (7.5 cm) distance to combustibles and keep attic insulation away from the vent pipe. Maintain an effective vapor barrier.
6. Finally, extend the pellet vent to go through the roof flashing.
7. Ensure that the rain cap is approximately 24" (600 mm) above the roof.

OUTSIDE VERTICAL INSTALLATIONS:

1. Install a tee with clean out on the outside of the house.
2. Install PL vent upward from the tee. Make sure that you install support brackets to keep the vent straight and secure.
3. Install ceiling thimble and secure the flashing as you go through the roof.
4. Ensure that the rain cap is approximately 24" (600 mm) above the roof.

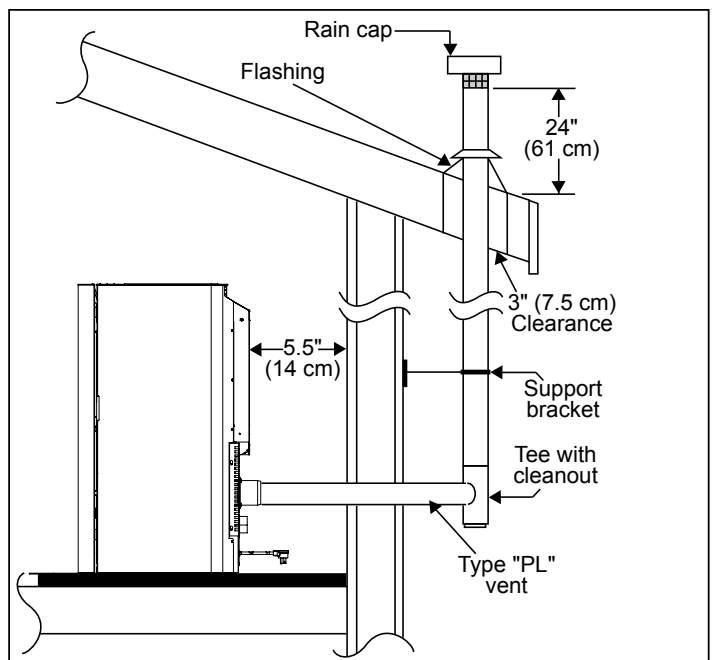

Figure 15: Outside Vertical Installation

HEARTH MOUNT INSTALLATION:

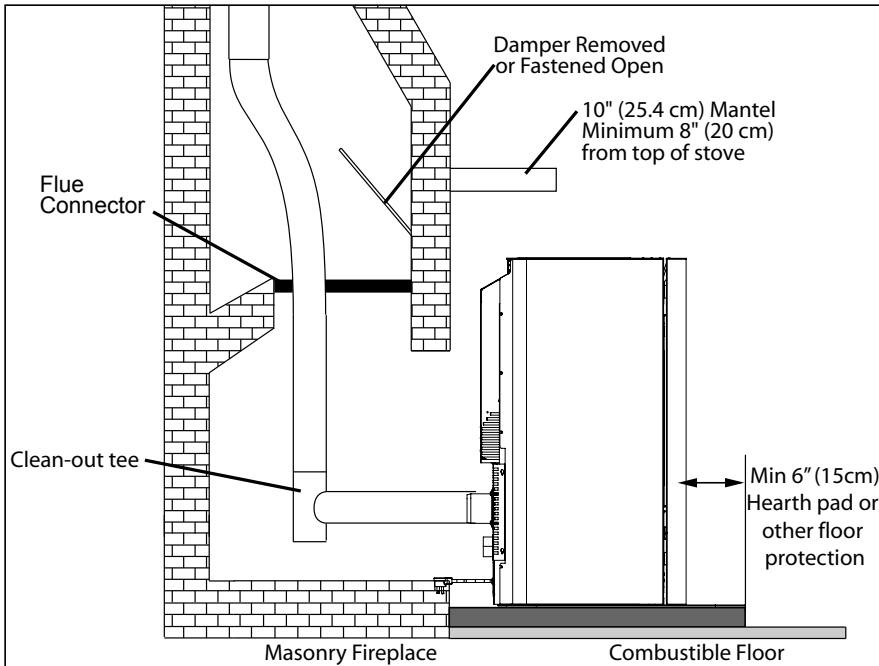

Figure 16: Freestanding Hearth Mount Installation

Refer to Figures 16 and 17.

1. Install the hearth pad.
2. Lock the fireplace damper in the open position.
3. Install a positive flue connector at the fireplace dampers or seal the chimney at the top.
4. Connect a tee to the exhaust pipe.
5. Install flexible stainless steel liner or listed pellet vent to the top of the chimney.

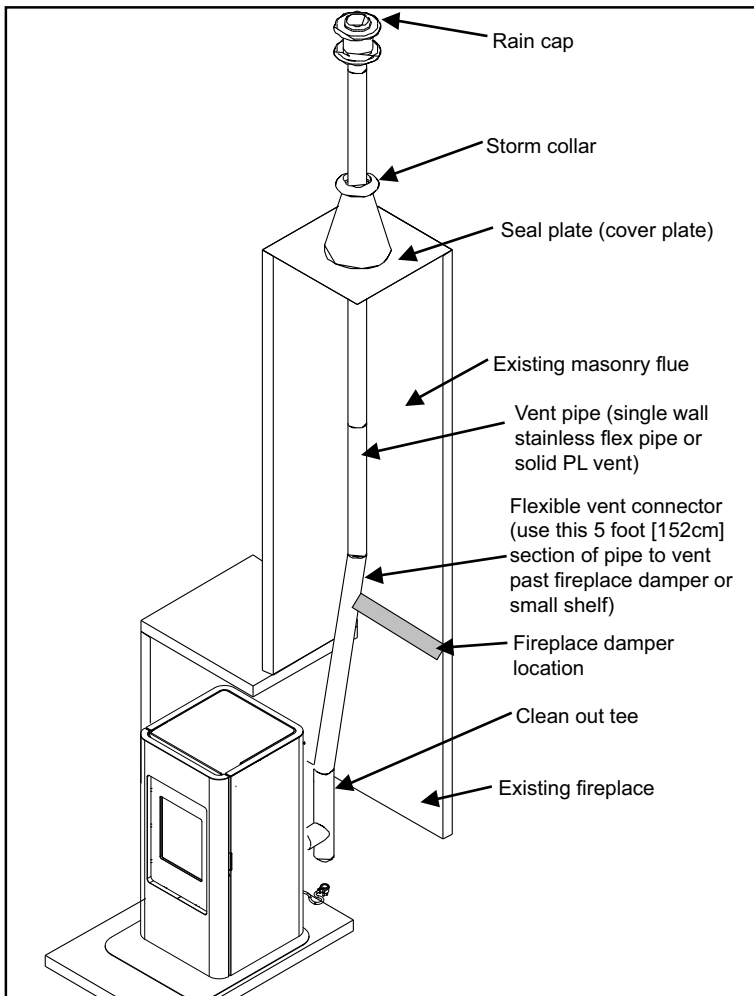
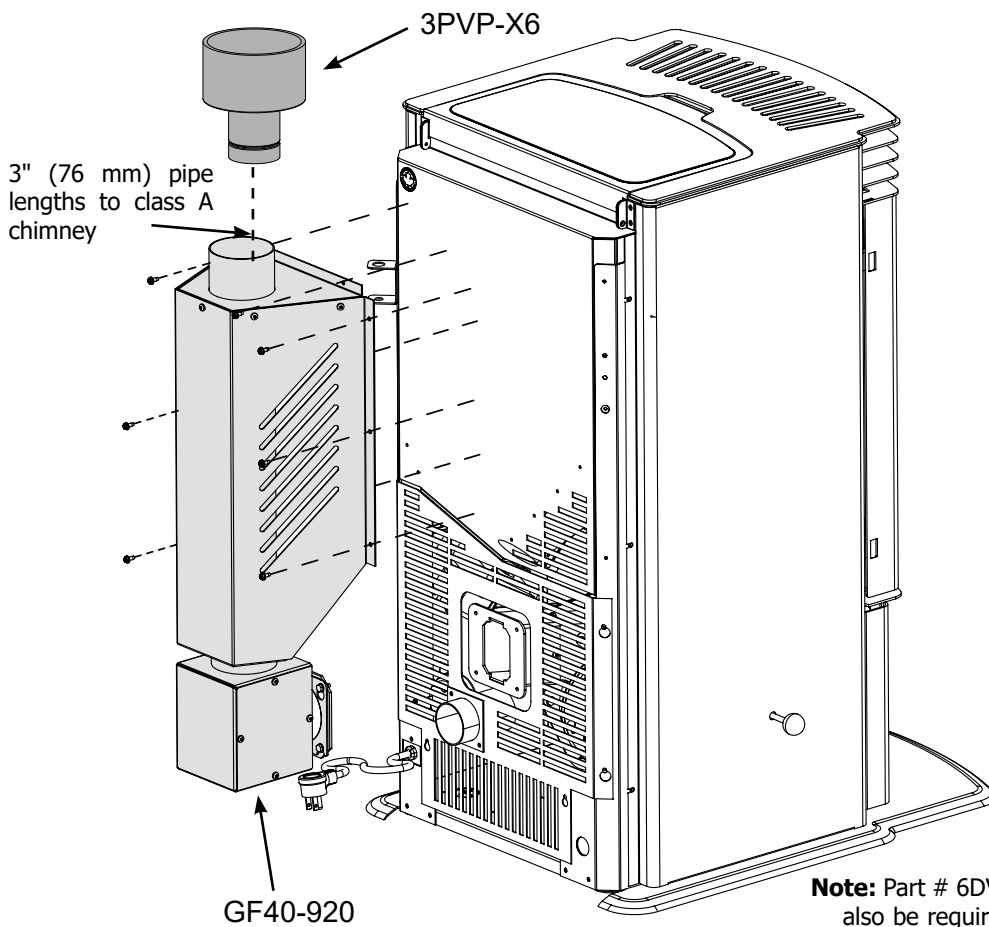

Figure 17: Freestanding Hearth Mount Installation Overview

TOP VENT ADAPTOR KIT & 3" (76 mm) TO 6" (152 mm) FLUE ADAPTOR (APPROVED FOR VERTICAL INSTALLATIONS ONLY)



*In order to achieve the maximum rated efficiency of 80.2% HHV purchase of a top vent adaptor kit (GF40-920) is required.

Use the sheet metal screws provided to attach the kit to the rear of the unit as shown. Please see kit instruction manual for more detailed installation instructions.

The stove must also be connected to a 6" (152 mm) Class A flue (where permitted) using the 3" (76 mm) to 6" (152 mm) Flue Adaptor (3PVP-X6).

See separate instruction manual for complete details.

Note: Part # 6DVL-ADT Simpson Duravent DVL adaptor would also be required to connect the 3" (76 mm) - 6" (152 mm) increaser to class A chimney when going through the wall or ceiling when using Simpson Duravent Duraplus/Duratech chimney systems. Not required with DuraTech Premium or DuraTech Canada. DTC ceiling supports feature a built-in flue extension which eliminates the need for this Simpson Duravent DVL adaptor.

THERMOSTAT INSTALLATION:

1. Install the wall thermostat in a location that is not too close to the unit but will effectively heat the desired area.
2. Install a 12 or 24 Volt Thermostat using an 18 x 2 gauge wire from the unit to the thermostat.

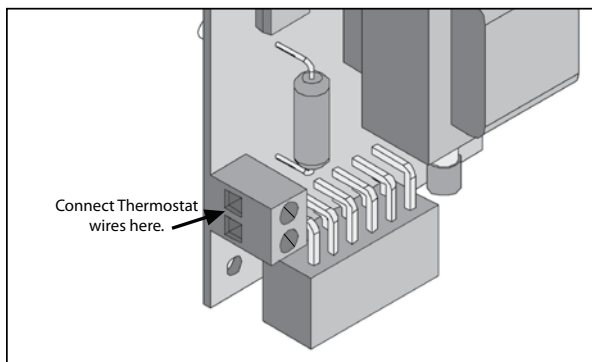

Thermostat Wire Placement

If the unit has been placed in the HI / LOW mode, the unit will be taken to a low or idle setting when the thermostat is not calling for heat. When the thermostat calls for heat, the unit will go to the setting that is displayed on the control board Heat Indicator.

THERMOSTAT INSTALLATION

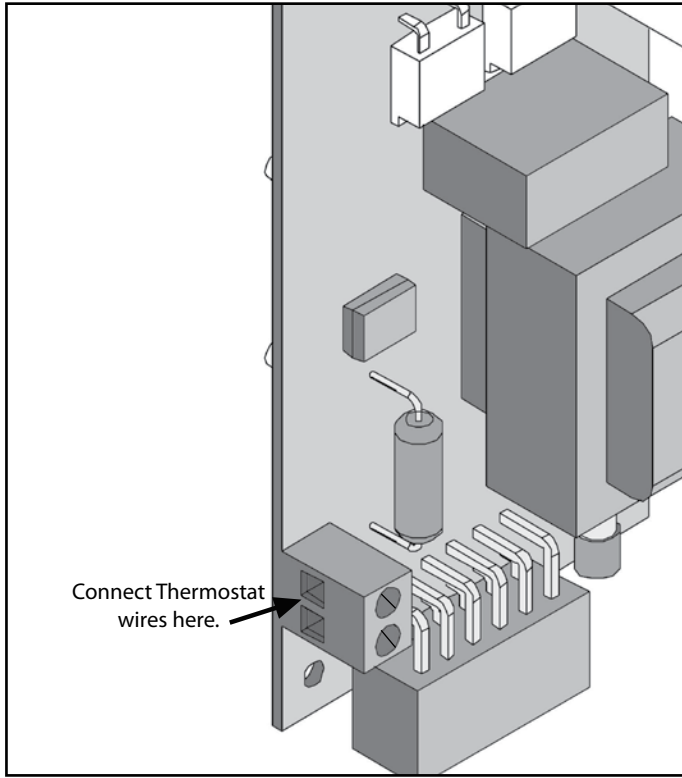

Figure 26: Thermostat Wire Location

1. Remove the outer door and the right side cabinet for easy access to screws securing unit to pallet, there are four T-20 screws at the front and three at the back of each cabinet side.
2. Loosen four T-20 screws securing Bottom Back Grill, once loose, slide down and remove.
3. The harness will need to be unplugged from the board in order to move cabinet side away from the unit. Once the harness is unplugged you can easily access the circuit board and will be able to attach the thermostat connection shown in Figure 26.
4. Use a small flat head screwdriver to tighten and secure the wires. The wires should be run through the plastic bushing located at the back of the stove, opposite side from the power cord.
5. Reverse steps 3-1

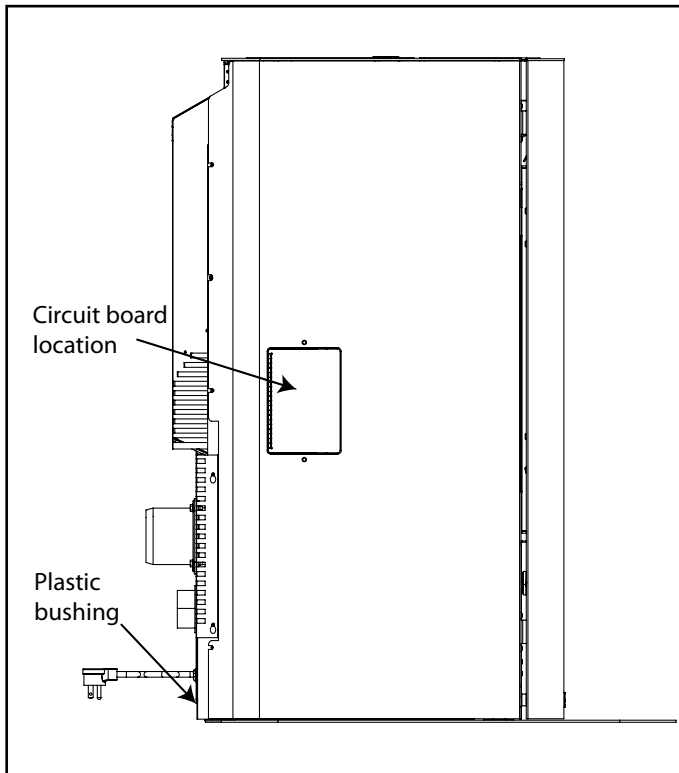

Figure 26a: Circuit Board Location

CONTROL BOARD FUNCTIONS

1. AUGER LIGHT:

This green light will flash in conjunction with the auger pulse.

2. MODE LIGHT:

Responsible for signaling the state of the control board. When the light is flashing the stove is in an automatic start mode or the thermostat has control of the unit. When the light is solid, the Heat Level Setting can be altered.

3. THERMOSTAT SWITCH:

Used to set the unit's controls to one of three mode settings; Manual, High/Low, or Auto/Off.

4. FEED RATE TRIM BUTTON:

Used to change the feed rate trims in ¼ second increments for all feed settings.

When this button is pressed, all the light will light up on the Heat Output Indicator except for the one that shows the current setting; the default setting is the number 4 light. To adjust the setting hold the Feed Rate Trim button down and press the Heat Level up or down buttons to adjust the setting.

5. COMBUSTION BLOWER TRIM BUTTON:

Used to change the Combustion Blower trims in 5 volt increments for all feed settings until it reaches line voltage. When this button is pressed, all the light will light up on the Heat Output Indicator except for the one that shows the current setting; the default setting is the number 2 light. To adjust the setting hold the Combustion Blower Trim button down and press the Heat Level up or down buttons to adjust the setting.

6. ON/OFF BUTTON:

Used to turn the unit On and Off.

7. ROOM AIR FAN ON/OFF BUTTON:

Used to turn convection fan On or Off.

8. HEAT LEVEL ADJUSTMENT BUTTONS:

When pressed, will change the heat level setting of the unit up or down.

9. HEAT OUTPUT INDICATOR:

Shows the present heat output setting.

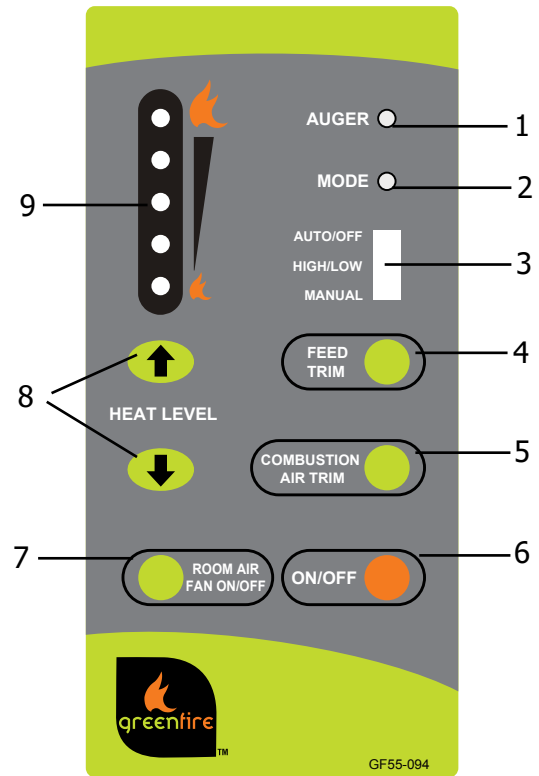

AUTOMATIC SAFETY FEATURES OF YOUR PELLET STOVE

- A. The stove and insert have a low limit safety switch located on the housing of the exhaust blower. If the exhaust temperatures drop below 120°F (49°C) the unit will shut down and will be required to go through a full start up procedure again. You will see a flashing #3 Error code. The most common cause for this is an empty hopper. This switch should only be by-passed for testing purposes by a technician.
- B. The stove has a high limit safety switch located just below the hopper behind the external body panels. If the temperature of this switch reaches 200°F (93°C) the auger will stop feeding fuel and the unit will shut down. There will be a flashing #4 error code. The 200°F (93°C) switch is a manual reset and should only be reset by a service person who can first diagnose the reason for failure. The two most likely causes are Convection Fan failure or High Limit Switch failure. Either one needs to be properly diagnosed and rectified. Since this is a safety switch it should never be by-passed for any reason other than the service technician to test the operation.

- C. The unit is equipped with a vacuum switch to monitor the venting pressure; if it becomes blocked or the combustion fan fails the vacuum switch will turn off the auger and there will be an **#2** flashing error code.

OPERATION YOUR PELLET STOVE

PRE-BURN INSTRUCTIONS: The burn pot liner holes must be clear and the liner installed properly against the ignitor tube for proper operation. Check the hopper for enough pellets to start the unit.

DO NOT OPERATE THE UNIT WITH THE DOOR OR ASH PAN OPEN.

MANUAL MODE:

All control of circuit board function is adjusted at the circuit board. To START: Press the ON / OFF button. The stove will turn on. The system light will flash. The Auger Light will flash with each pulse of the auger (the Auger Feed Rate is pre-programmed during start-up). The Heat Level Indicator will show the Heat Level that the stove will run at after start-up and can be adjusted but the change will not take affect until the start-up has finished. If this is the first time the unit has been started or the unit has run out of fuel, the auger will need to be primed. This can be done by restarting the unit five (5) minutes into its start-up or by putting a small hand full of pellets into the burnpot.

TO OPERATE: When a fire has been established, the System Light will turn solid (after approximately 10 - 15 minutes) and the Auger Light will continue to flash to the corresponding Heat Level setting. The convection blower (room air blower) will turn on. The speed of this blower is controlled by the setting of the heat level output indicator. The convection blower can be turned OFF by depressing the convection blower control button. For the best efficiency the convection blower should be left on at all times.

HIGH/LOW MODE: (Requires a thermostat) INITIAL START-UP: See manual mode above.

OPERATION: When the thermostat calls for heat (contacts are closed) the stove settings are adjustable as per Manual Mode. When the thermostat contacts open, the HEAT LEVEL and Fans will drop down to the LOW setting until the thermostat contacts close again. *The LOW heat setting can be adjusted for different fuel qualities (see "Operating Instructions - Control Board Functions"). The stove will come back to the previous HEAT LEVEL setting when the thermostat contacts close again.

AUTO/OFF MODE: (Requires a thermostat) INITIAL START-UP: See manual mode above.

OPERATION: When the thermostat contacts close, the unit will light automatically. Once up to temperature, the stove operates the same as in MANUAL. When the thermostat contacts open, the stove's HEAT LEVEL and Fans will drop down to the LOW setting for 30 minutes. If the thermostat contacts close within the 30 minutes, the HEAT LEVEL will return to the previous MANUAL setting. If the thermostat contacts remain open the stove automatically begins its shutdown routine. The ON / OFF button can be pressed at any time the the stove will immediately shut down. The stove will relight when the thermostat contacts close again.

TURNING YOUR PELLET STOVE OFF

- MANUAL and HI / LOW mode: To turn the unit OFF, simply press the ON / OFF button. This will stop the feed of pellets. The blowers will continue to operate and cool the stove down. When cool enough, the stove will turn off.
- AUTO / OFF mode: To turn the unit OFF, turn the thermostat down or off. NOTE: The unit will run on low for three (3) minutes before it turns off.

NEVER unplug a unit that is running!

DO NOT unplug unit while Combustion fan is running.

Unplugging may cause smoke to be released into the home.

SLIDER / DAMPER SET-UP

THE SLIDER/DAMPER HAS BEEN SET AT THE FACTORY.

This is used to regulate the airflow through the pellet stove. This slider damper is located inside the stove on the left hand cabinet side (Not shown).

The slider damper factory setting has been set for peak efficiency operation (see figure 30).

If the fire should happen to go out and the heat output indicator has been set on the lowest setting, the Slider Damper may need to be adjusted by a qualified technician only. Contact your local dealer.

For troubleshooting purposes the firebox vacuum pressure may need to be confirmed. This should be done only on a hot stove (operating for thirty (30) minutes or more) by placing a Magnahelic Pressure Gauge in the firebox. The reading can be taken from 1/8" (3 mm) hole located in the front of the firebox under the door. **The factory setting should read approximately 0.06 inches of water column on the high fire setting.**

SPECIAL NOTES:

Pellet quality is a major factor in how the Pellet stove will operate. If the pellets have a high moisture content or ash content the fire will be less efficient and has a higher possibility of the fire building up and creating clinkers (hard silica ash build-up).

Overfiring should not occur if stove is operating properly, if stove looks like it is burning unusually high turn off the unit with the power button, **DO NOT** unplug. There is a built in safety switch if unit gets too hot from overfiring it will shut down automatically.



Figure 30: Efficient Flame

GUIDELINES FOR FINE-TUNING FOR FUEL QUALITY

Due to fuel quality the slider damper and control board trims may need to be fine-tuned.

1. If the unit builds up on all settings, the slider damper rod should be pulled out in small increments to give the unit more air.
2. If the unit has excesses ash build-up in the liner on the lower feed settings, the Combustion Blower Trim should be increased one setting at a time until the problem improves (Factory Setting is #2).
3. If the fire is going out on low because the airflow is too great, the Combustion Blower Trim can be lowered to the #1 setting.
4. If the stove has excesses ash build-up in the liner on the higher settings the Feed Rate Trim should be trimmed down a setting at a time until the problem improves (Factory setting is #4).
5. If you need more heat and the fuel has long pellets, the majority are over 1" (2.5cm) in length, the Feed Rate Trim can be moved up to the #5 setting. NOTE: Only do this if the fuel burns without build-up.

Routine Cleaning and Maintenance

The following list of components should be inspected and maintained routinely to ensure that the appliance is operating at its optimum and giving you excellent heat value:

<u>2-3 Days / Weekly</u>	<u>Semi-annually or 2 Tons of Fuel</u>
Burn Pot and Liner	Exhaust Vent
Heat Exchanger Tubes	Air Intake
Ash Pan	Blower Mechanisms
Door Glass	Heat Exchanger Tubes
Inside Firebox	Behind Firebox Liners & Covers
Ash Pan and Door Gaskets	All Hinges
Door Latch	Post Season Clean-up

IMPORTANT : The purchaser is responsible for the annual maintenance of the Appliance, as outlined in the owner's manual. The warranty may be voided due to problems caused by a lack of maintenance. Records/receipts of all maintenance completed by service companies must be kept in case asked for if there is warranty on the product.

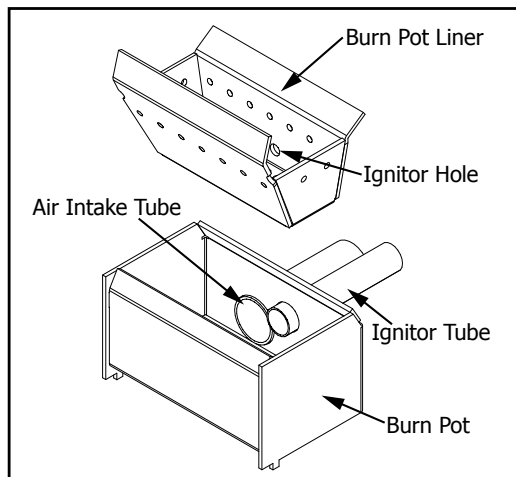

Figure 32: GF40 Burn Pot and Liner

TOOLS REQUIRED TO CLEAN UNIT:

Torx T-20 Screwdriver, $\frac{5}{16}$ " wrench or socket, Brush, Soft Cloth, Vacuum with fine filter bag

BURNER POT AND LINER (2-3 days)

Every two to three days (when the unit is cold), remove the burn-pot liner from the stove. Using a metal scraper, remove material that has accumulated or is clogging the liner's holes. Then dispose of the scraped ashes from the liner and from inside the burn-pot. Place the burn-pot back into the stove, making sure that the pipes are properly inserted into the burn pot. Place the liner back into the burn-pot, making sure that the ignitor hole in the liner is aligned with the ignitor tube (shown in Figure 32). Push the liner up against the ignitor tube.

If after long periods of burning, the fire continually builds up and overflows the burn pot or there is a build up of clinkers, this is an indication that the pellet fuel quality is poor, the stove may need cleaning, or the air adjusted. Check the stove for ash build up (clean if required) and adjust the damper to produce the proper clean combustion.

HEAT EXCHANGER TUBES (2-3 days)

A rod is located in the center of the stove just above the door behind the top louvers, see Figure 35. This rod is to be pulled up and down a few times (ONLY WHEN THE UNIT IS COLD) in order to clean away any fly ash that may have collected on the heat exchanger tubes. As different types of pellets produce different amounts of ash, cleaning of the tubes should be done on a regular basis to enable the unit to run efficiently. Do not pull on rod excessively if it is not sliding. If stuck inspect rod for bend and try and free up scraper plate from inside firebox.

ASH PAN AND DOOR GASKETS (weekly)

After extended use the gasket may come loose. To repair this, glue the gasket on using high-temperature fiberglass gasket glue available from your local dealer. This is important to maintain an airtight assembly.

Routine Cleaning and Maintenance

DOOR GLASS CLEANING (2-3 days)

Cleaning of the glass must only be done when stove is cold. Open the door. The glass can be cleaned by wiping down the outside and inside of the glass with a soft dry cloth.

If the glass has build up that can not be removed with only the cloth, clean the glass using paper towel and a gas appliance glass cleaner, this may be purchased through most dealers. If a gas appliance glass cleaner is not available, use a damp paper towel dipped in fly ash to clean the glass. After the glass has been cleaned use the dry soft cloth to wiping down the outside and inside of the glass.

FIREBOX & ASH PAN (weekly)

This part is located behind the bottom door. To remove the ash pan, open the cover from the right hand side, and lift the ash pan up and out. Dump the ashes into a metal container stored away from combustibles. Monitor the ash level of the firebox every week and vacuum out as needed.

Remember that different pellet fuels will have different ash contents. Ash content is a good indication of fuel efficiency and quality. Refer to "SAFETY WARNINGS AND RECOMMENDATIONS" for disposal of ashes. Vacuum the inside of the ash pan compartment inside the pedestal including the hole at the top back of the compartment. Replace the ash pan, close the latch, and close pedestal door. **DO NOT PLACE UNBURNED OR RAW PELLET FUEL IN ASH PAN.**

AIR INTAKE (semi-annually)

Inspect periodically to be sure that it is not clogged with any foreign materials.

EXHAUST PASSAGES (Semi-annually)

To prevent build up of fly-ash all the exhaust passages must be cleaned and vacuumed.

Clean behind clean-out covers:

- Open ash box cover.
- Remove ash box.
- Using a 5/16" socket, loosen the six screws in the ash box compartment; four on the back.
- Rotate the back cover counter clockwise

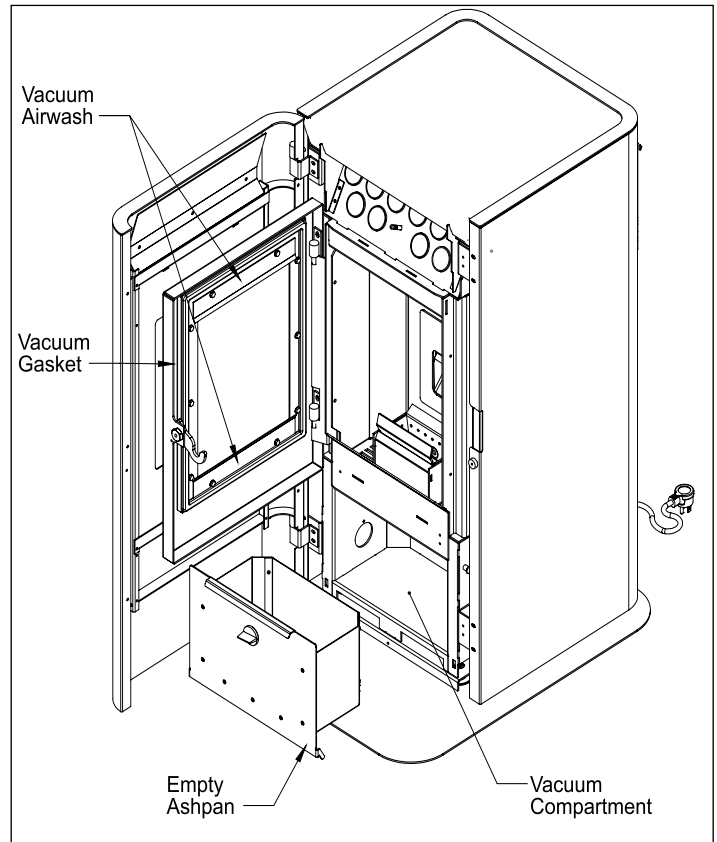

Figure 33: GF40 Open

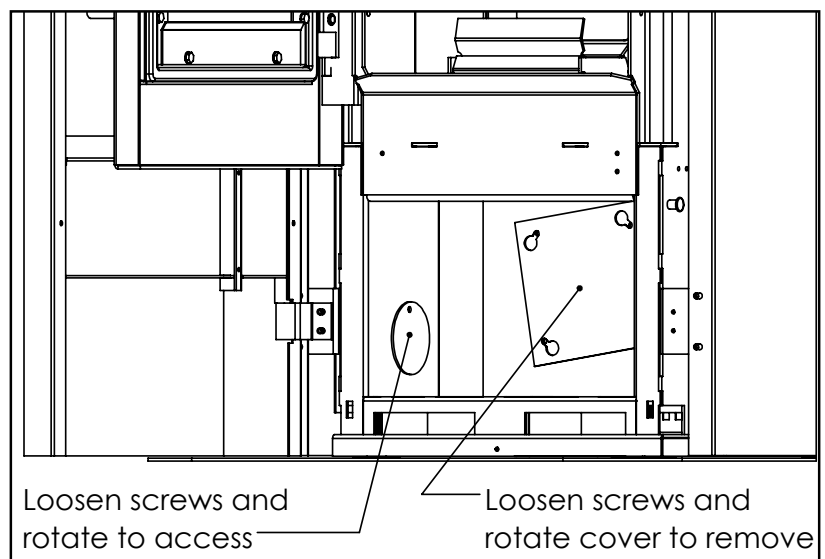

Figure 34: GF40 Clean-Out Covers

Routine Cleaning and Maintenance

- Remove and rotate the side covers to open them.
- Vacuum out all three chambers.
- Close all the clean-out covers

HEAT EXCHANGER TUBES (2-3 days)

- The heat exchanger tubes are located behind the Louver assembly. To access Heat Exchanger Scraper Rod, remove middle two louvers by tipping up and pulling out.
- Pull out the Scraper Rod shown in Figure 35 in order to remove any fly ash that may have collected on the heat exchanger tubes. This will allow for optimal heat transfer to convection air.

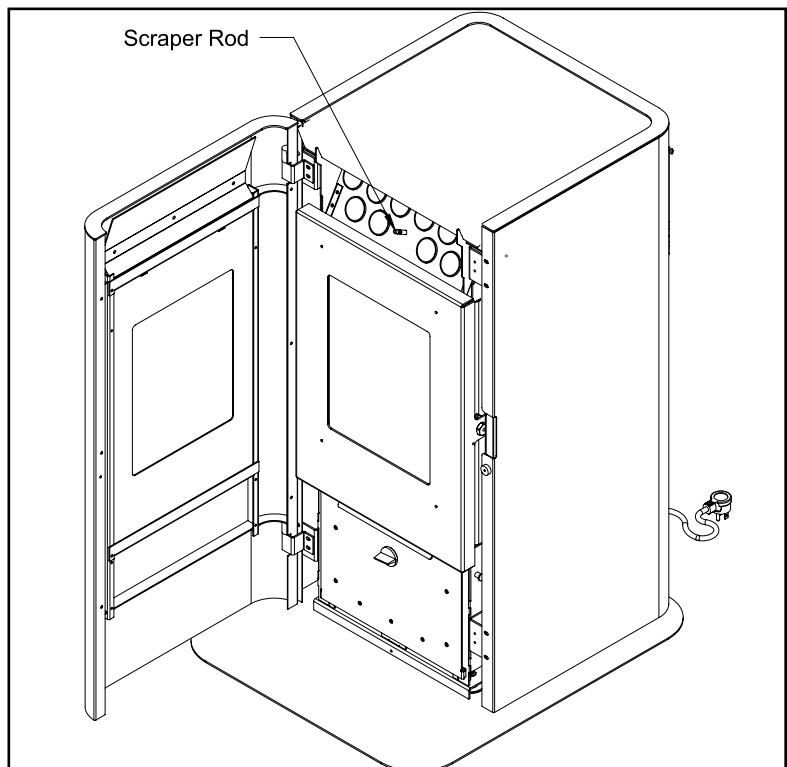

Figure 35: GF40 Heat Exchanger Tubes

REMOVAL OF FIREBOX PANELS

- Open the door, remove the door, burn pot and burn pot liner.
- Lubricate all screws with penetrating oil.
- Remove the four screws that hold the side panels in place.
- With the tip of a flat screwdriver, gently lift up the side panels and remove the side panels.
- Pull the center panel out.
- Vacuum thoroughly.
- Re-install panel by inserting center panel.
- Place the side panels back into the firebox locking them into place and re-install the two screws on each side.
- Clean thoroughly.

Note: Screws that secure left side panel also secure hinge bracket which holds the door. Remove door before unscrewing.

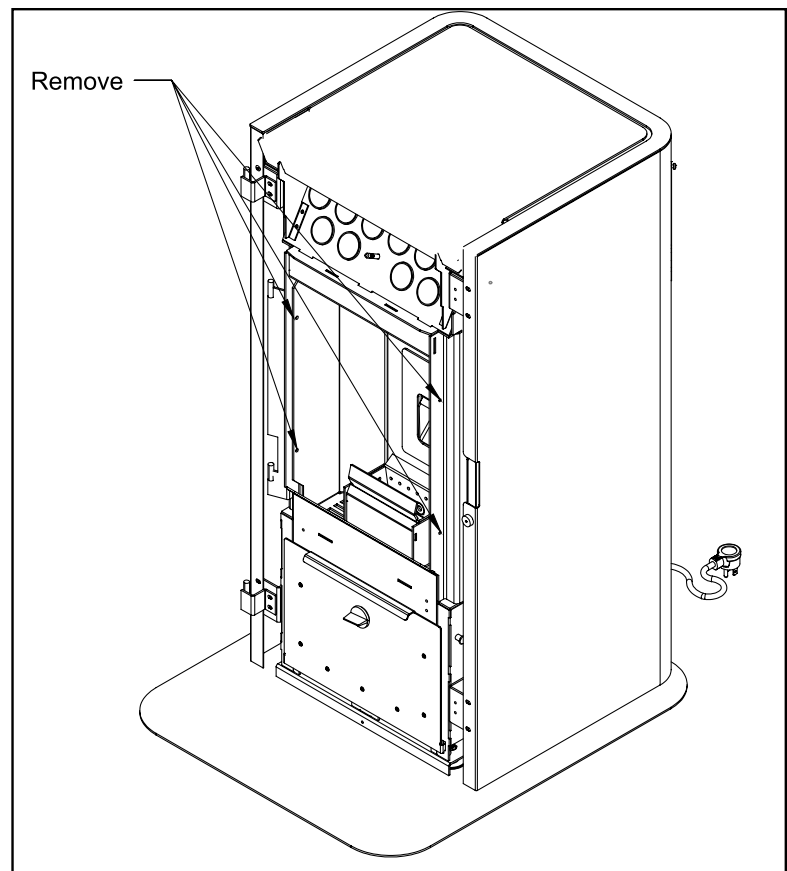

Figure 36: GF40 Firebox Panels

Routine Cleaning and Maintenance

FIREBOX (weekly)

The paint on the steel firebox panels may peel. This is due to extreme conditions applied to the paint and is in no way covered by warranty. Brush and vacuum up all soot and flyash from firebox.

AIR WASH (semi-annually)

Vacuum out the air wash passages at the top of the glass (see Figure 33). We recommend that a soft brush nozzle head is used on the vacuum.

EXHAUST VENT (semi-annually)

This vent should be cleaned every year or after two tons of pellets. We recommend contacting your dealer for professional cleaning. To clean the vent pipe, tap lightly on the pipe to dislodge any loose ash. Open the bottom of the "T" to dump the ash, then vacuum as much of the ash out of the vent pipe as possible. Failure to clean exhaust venting can result in a serious creosote fire.

BLOWER MECHANISMS (semi-annually)

Unplug the stove then open the right and left side panels to access the two blowers. Vacuum all dust from motors. DO NOT lubricate the motors. Check gaskets and replace if needed.

HINGES

Check to make sure all hinges are working properly. You may use high temp anti-seize on door hinges for smoother operation.

POST SEASON CLEAN-UP

Once you are finished using the pellet appliance for the season, unplug the stove for added electrical protection. It is very important that the stove be thoroughly cleaned and serviced. Pellet stove should be regularly service for optimum efficiency and prolonged life.

DOOR GLASS REPLACEMENT

Never run a stove with broken glass, new glass must be purchased and installed by a Regency dealer. The door glass is made of high temperature "PYROCERAM" ceramic glass. The proper glass size is 13" x 9.5" x 0.2" (5mm). To replace the glass, unscrew and remove the seven retainer screws. Carefully remove the glass and any broken pieces using protective gloves. High temperature fiberglass tape should be used around the glass on the sides and bottom. Place glass with fiberglass tape around outside into cast door, there should be no gasket at the top. Use the same retainers to secure the glass in place, make sure glass is properly seated in the cast door before tightening screws. Do not strike or slam door shut this can cause glass to break. The use of substitute glass materials is prohibited use only part 50-2942.

Troubleshooting

DO NOT:

- Service the stove with wet hands. The stove is an electrical appliance, which may pose a shock hazard if handled improperly. Only qualified technicians should deal with possible internal electrical failures.
- Do not remove from the firebox any screws without penetrating oil lubrication.

WHAT TO DO IF:

1. The stove will not start.
2. The stove will not operate when hot.
3. The exhaust blower will not function normally.
4. Light # 2 on Heat output bar flashing.
5. Auger light flashes but auger motor does not turn at all
6. Light # 4 on Heat output bar flashing.
7. The convection blower will not function normally.
8. Igniter- the pellets will not light.
9. Control settings (Heat Level) has no effect on the fire.
10. The stove keeps going out.

***NOTE: All troubleshooting procedures should be carried out by qualified technicians or installers.**

1. The stove will not start.

- Make sure the stove is plugged in and the wall outlet is supplying power.
- If the Control Board has been placed in the ON /OFF thermostat mode, then turn the thermostat up to call for heat.
- Check the Heat Level Indicator. - If the # 2 light is flashing (see the # 2 light is flashing)
- Check the fuse on the circuit board.
- If the unit still does not start, contact your local service dealer for service.

2. The stove will not operate when hot.

- Check the Heat Level Indicator if a fire is not detected, or if the fire has gone out the #3 light will flash because the Exhaust Temperature Sensor's contacts have opened.
- Check the hopper for fuel.
- Incorrect air damper setting. - Excessive air may consume the fire too quickly before the next drop of fuel, leaving completely unburned fuel in the burn pot liner. - Insufficient air will cause build up, further restricting the air flow through the Burn Pot Liner. This in turn will cause the fuel to burn cold and very slowly. Fuel may build up and smother the fire. In this case clean the burn pot. (NOTE: unit may require a change to the vent system or installation of fresh air to correct Air to Fuel ratio problems).
- Combustion Blower failure. - The Combustion Blower is not turning fast enough to generate the proper vacuum in the fire box. Visual Check – is the blower motor turning.
- Check the Exhaust Blower voltage across the blower wires ($\geq 114V$ on #5 setting and $\geq 82V$ on #1 setting). – Replace the Circuit Board if the Voltage reading is less than 82 V. with a line voltage $>114 V AC$.
- Check Vacuum levels in the exhaust channel by bypassing the Vacuum Switch, then remove the Vacuum hose from Vacuum Switch. Check exhaust vacuum readings by placing the open end of the Vacuum Hose on a Magnahelic Gauge (readings must be above .10" W.C. on low fire).

If the motor fails to reach a 0.10" W.C. readings, then replace the Combustion Blower.

3. The exhaust motor will not function normally.

- Open the left side access panel; check all connections against the wiring diagram.
- See "2. The stove will not operate when hot." section.

4. Light # 2 on Heat output bar flashing. (The Vacuum Switch contacts have opened for more than 15 sec.)

- Pinch, break or clear blockage in Vacuum Hose - Check hose for pinch points or damage, replace or re-route as required. Blow out Vacuum Hose

Troubleshooting

- **Blocked Hose Barb on Exhaust Channel** - Use a paper clip to clean out Hose Barb or remove the Vacuum Hose from the Vacuum Switch and blow into the hose to remove blockage.
- **Blocked exhaust / venting system** - Have stove and venting cleaned and inspected.
- **Severe negative pressure in area where unit is installed** - Check the operation by opening a window, does this solve the problem? If it does, install fresh air intake to unit or room. Venting system may require vertical section to move termination into a low pressure zone.
- **Vacuum Switch failure** - Bypass the vacuum switch, if this corrects the problem check for above problems before replacing the Vacuum Switch.
- **Damage to gray wires between Circuit Board and Vacuum Switch** - Inspect wires and connectors
- **Combustion Blower failure** - The Combustion Blower is not turning fast enough to generate the proper vacuum in the Exhaust Channel. Visual Check; is the blower motor turning? Check the Exhaust Blower voltage across the blower wires ($\geq 114V$ on #5 setting and $\geq 82V$ on #1 setting). – Replace the Circuit Board if the Voltage reading is less than 82 V. with a line voltage $>114 V AC$.
- **Check Vacuum levels in the exhaust channel by bypassing the vacuum switch, then remove the Vacuum hose from Vacuum Switch.** Check exhaust vacuum readings by placing the open end of the Vacuum Hose on a Magnahelic Gauge. (readings must be above .10" W.C. on low fire). If the motor fails to reach a 0.10" W.C. readings, then replace the Combustion Blower To reset Circuit Board after a trouble code - push the ON/OFF button.

5. Auger light flashes but auger motor does not turn at all.

- **If the Auger gear box does not turn but the motor's armature does try to spin then the auger is jammed.**– Try to break apart jam by poking at the jam through the drop tube. If this fails then empty the hopper and remove the Auger Cover ****Remember to re-seal the cover after installation****
- **Check the fuse on the circuit board.**

6. Light # 4 on Heat output bar flashing.

- **Reset high limit sensor and determine cause – was it Convection Blower failure?**

NOTE: DO NOT attempt any electrical troubleshooting without knowledge of electrical systems, make sure unit is not plugged in. It is recommended to call an authorized Regency dealer or service technician.

7. Ignitor- the pellets will not light.

- **Everything else in the stove operates but the ignitor will not light the pellets.**
- **Make sure the burn pot liner is up tight and square to the ignitor tube by pushing the burn pot back against the ignitor tube.**
- **Check to see if the exhaust blower is operating. If not, contact your local dealer for service.**
- **Check the fuse on the circuit board.**

NOTE: The ignitor should be bright orange in color. If not replace the ignitor.

8. Control settings (Heat Level) has no effect on the fire.

- **NOTE: If the system light is flashing the Control Board has complete control of the unit. When the units system light becomes solid then control of the unit is given back to the operator.**
- **If there is no control of the Heat Level button make sure the thermostat is calling for heat.**

Troubleshooting

- Call your local dealer for service.

9. The stove keeps going out.

If the stove goes out and leaves fresh unburned pellets or cigarette-like ashes in the burn pot liner, the fire is going out before the stove shuts off.

- Check to see that the Slider / Damper is in the correct position (set with a manometric gauge).
- Turn the Heat Level up slightly (poor quality pellets will require slightly higher settings).

If the stove goes out and there are partially burned pellets left in the burn pot liner, the stove has shut down due to a lack of air, exhaust temperature, or power failure:

- Adjust the Slider / Damper.
- Adjust the trim settings
- Check to see if the stove needs a more complete cleaning.
- Turn the Heat Level up slightly (poor quality pellets will require slightly higher settings).
- Did the power go out?
- Contact your local Dealer for service.

Wiring Diagram

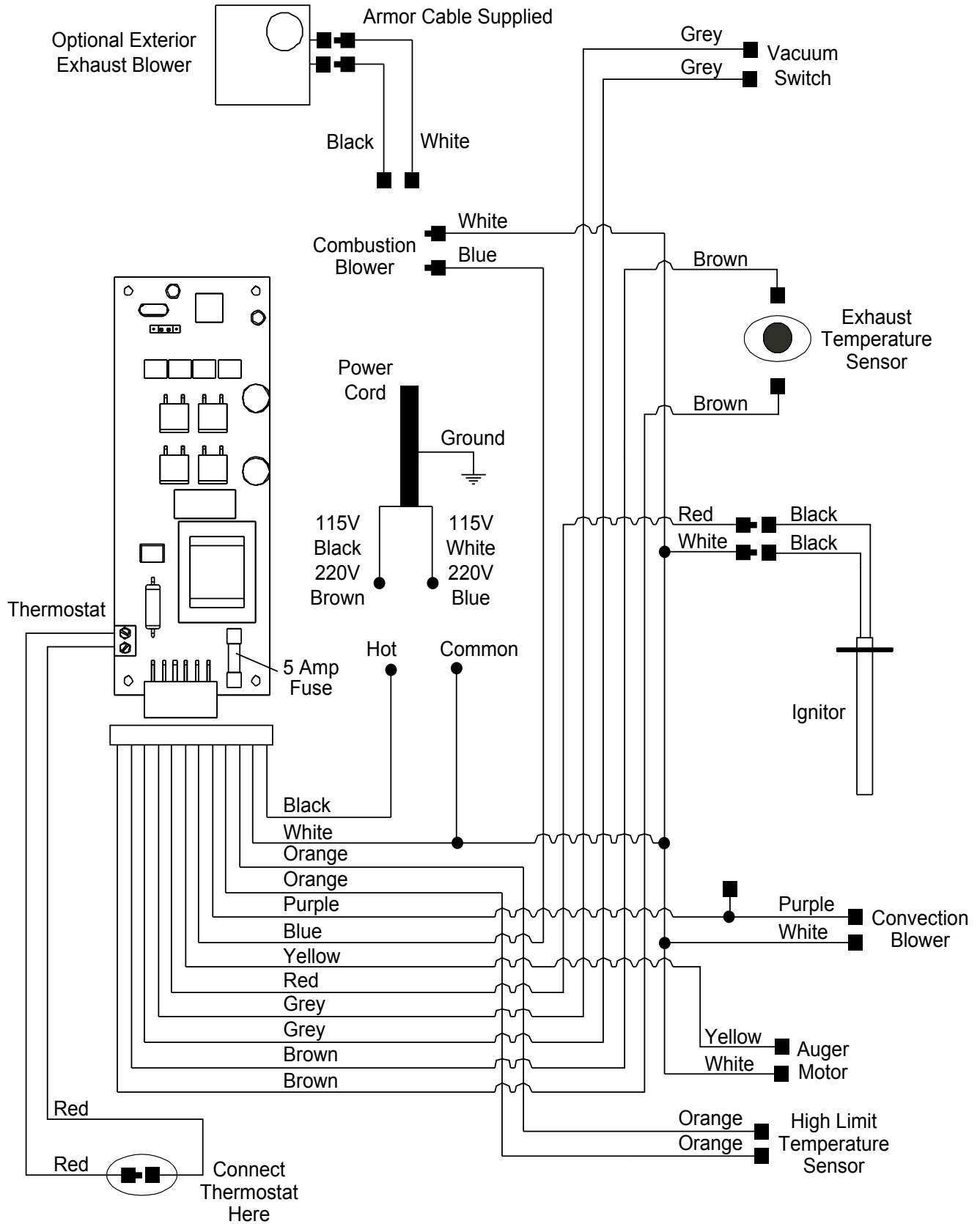

Ref. #	Part #	Description
1	GF55-009	120°F EXHAUST TEMP SENSOR
2	GF55-001	AUGER MOTOR 115 VOLT
3	GF55-011	200 DEGREE F. HIGH LIMIT SENSOR MANUAL RESET
4	GF55-012	VACUUM SWITCH
5	GF55-013	SILICONE HOSE
6	GF40-006	SS ASH PAN LATCH
7	GF40-007	DOMESTIC POWER CORD
8	GF40-008	400 WATT IGNITOR
9	GF40-009	EXHAUST/COMBUSTION BLOWER ASSEMBLY 115 VOLT
10	GF40-010	CONVECTION BLOWER 115 VOLT
11	GF40-011	LEVELING LEGS (SET OF 4)
12	GF40-012	DOOR GASKET ROPE
13	GF40-013	GLASS WITH GASKET
14	GF55-093	CIRCUIT BOARD
15	GF55-094	CONTROL PANEL DECAL
16	GF40-016	AUGER
17	GF40-017	HEAT EXCHANGER SCRAPER ROD
18	GF40-018	DRAFT SLIDER
19	GF40-019	DOOR HINGE BRACKET
20	GF40-021	BURN POT LINER
21	GF40-020	BURN POT
22	GF40-022	ASH PAN
23	GF40-023	INNER DOOR
24	GF40-024	OUTER DOOR
25	GF40-025	HEARTH PAD
26	GF40-026	CABINET SIDES (L & R)
27	GF40-027	BOTTOM CABINET SIDE BRACKETS
28	GF40-029	TOP CABINET SIDE BRACKETS
29	GF40-030	OUTER DOOR HINGE PINS
30	GF40-031	AUGER STOP PLATE
32	GF40-033	HOPPER LID
33	GF40-034	TOP TRIM
34	GF40-049	DOOR TOOL
35	GF40-039	STEEL DOOR LATCH
36	GF40-037	FIREBOX LINERS
37	GF55-033	EXHAUST STARTER TUBE C/W GASKET
37A	GF55-017	EXHAUST STARTER TUBE GASKET ONLY

Ref. #	Part #	Description
38	GF40-040	MACHINED DOOR NUT LATCH
40	GF40-041	ALUMINUM HOSE BARB (VACUUM LINE)
41	GF55-045	AUGER BRASS BUSHINGS (SET OF 2)
43	GF55-006	CIRCUIT BOARD FUSE (2 PCS)
44	GF55-047	5/8" ID AUGER COLLAR WITH SCREW
45	GF40-045	WIRE HARNESS
46	GC60-004	AUGER STOPS (CLEAR TUBE)
47	GF55-023	BURNPOT SCRAPER TOOL
48	GF55-048	CLEANING BRUSH
50	920-412	GF40 USERS MANUAL
51	GF40-012	DOOR GASKET ROPE
52	936-299	ASH PAN GASKET (SOLD PER FOOT/4 FEET REQUIRED)
53	GF55-015	COMBUSTION BLOWER MOUNTING GASKET
54	GF55-016	COMBUSTION BLOWER GASKET
55	GF40-920	TOP VENT ADAPTOR KIT
56	GF40-054	ASH COVER PLATE
N/S	GF40-053	MINI BACKDRAFT FLAP WITH OVAL GASKET
N/S	3PVP-X6	3" (76 MM) TO 6" (152 MM) FLUE INCREASER (SIMPSON DURAVENT)
N/S	6DVL-ADT	DVL ADAPTOR (SIMPSON DURAVENT)

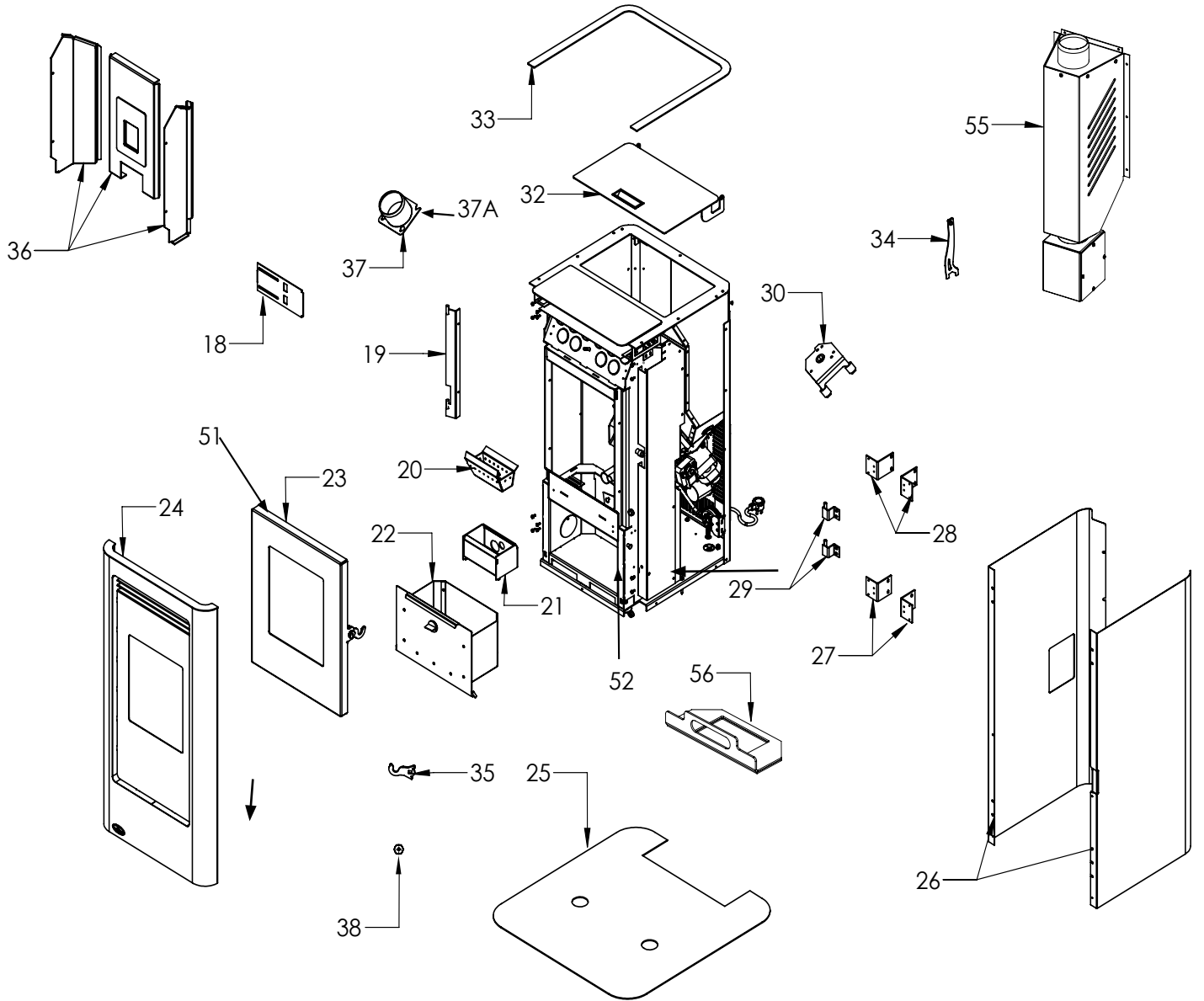

GF40 - STEEL

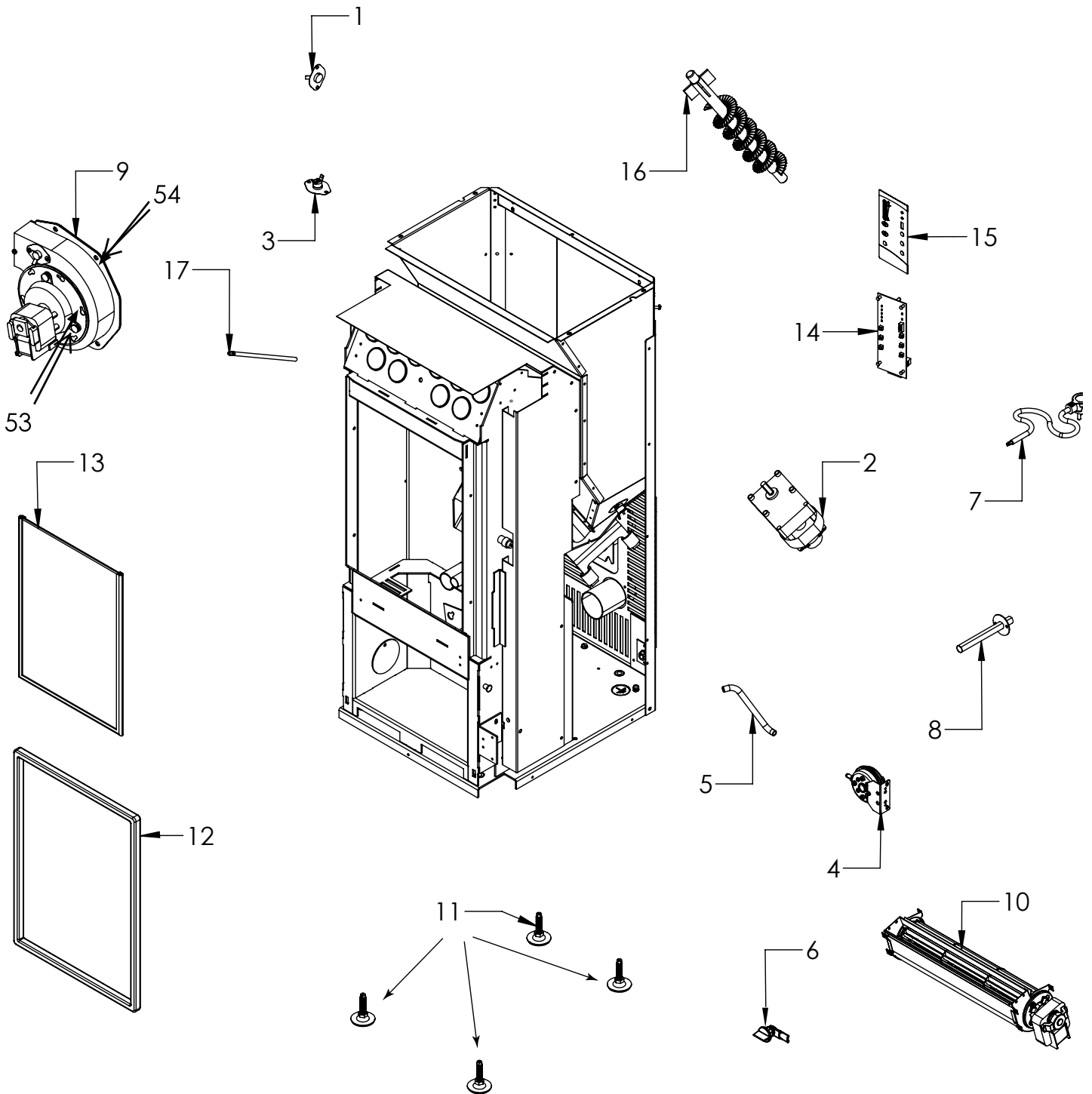

GF40 - COMPONENTS

Indoor Pellet Product Warranty

Limited Lifetime Warranty

FPI Fireplace Products International Ltd. (for Canadian customers) and Fireplace Products US, Inc. (for US customers) (collectively referred to herein as "FPI") extends this Limited Lifetime Warranty to the original purchaser of this Appliance provided the product remains in the original place of installation. The items covered by this Limited Lifetime Warranty and the period of such coverage are set forth in the table below.

*The term "Limited Lifetime" in the table below is defined as **7 years** beginning the date when the Appliance was purchased. The "Limited Lifetime" warranty coverage period (**7 years**) reflects the minimum expected useful life of the designated Appliance or component under normal operating conditions. Some conditions apply (see below).

An Appliance in this policy is defined as an Indoor Pellet stove and Pellet insert.

This Appliance has only been certified and listed for use indoors.

This Limited Lifetime Warranty starts on the day the Appliance was purchased.

The Limited Lifetime Warranty is not transferable, amendable or negotiable under any circumstances.

Indoor Pellet Products Warranty Coverage for Components and labor is as follows:	Limited Lifetime Component Coverage 7 years	2 years	Subsidized Labour Coverage (Years)**
*Firebox/Heat exchanger	✓		2
*Surrounds, castings, door assembly.	✓		2
*Burn Pot, Log sets, Firebox panels,	✓		2
*Ceramic Glass (Thermal Breakage)	✓		2
*Pedestals, legs	✓		2
Burn Pot Liner		✓	2
Agitator		✓	2
Auger Motor, Combustion blower, Convection blower		✓	2
Wiring, all switches, Wiring harness, Powercords		✓	2
Circuit boards, Circuit board ribbon cable		✓	2
Vacuum switch, Ignitor, Air pump, Temperature sensors, Wall thermostat		✓	2
Auger		✓	2
Circuit Board Decals		✓	
Hopper Rails/ Baffle		✓	2

Note: Warranty coverage noted above may not be applicable as components/options vary based on appliance purchased.

Conditions:

Warranty protects against defect in manufacture or FPI factory-assembled components only, unless herein specified otherwise.

****This warranty does not cover dealer travel costs, mileage, fuel, tolls for diagnostic or service work. All labor rates paid to authorized dealers are subsidized, pre-determined rates. Dealers may charge you for travel and additional time beyond their subsidy.**

Any part(s) found to be defective during the warranty period as outlined above will be repaired or replaced at FPI's option through an accredited distributor, dealer or pre-approved and assigned agent provided that the defective part is returned to the distributor, dealer or agent for inspection if requested by FPI. Alternatively, FPI

may, at its own discretion, fully discharge all of its obligations under warranty by refunding the verified purchase price of the product to the original purchaser. The purchase price must be confirmed by the original Bill of Sale.

The authorized selling dealer, or an alternative authorized FPI dealer if pre-approved by FPI, is responsible for all in-field diagnosis and service work related to all warranty claims. FPI is not responsible for results or costs of workmanship of unauthorized FPI dealers or agents in the negligence of their service work.

At all times, FPI reserves the right to inspect reported in the field/on location complaints of products claimed to be defective before processing or authorizing any claim. Failure to allow this upon request will void the warranty.

All warranty claims must be submitted by the dealer servicing the claim, including a copy of the Bill of Sale (proof of purchase by you). All claims must be complete and provide full details as requested by FPI to receive consideration for evaluation. **Incomplete claims may be rejected.**

Replacement Appliances to the original purchaser are limited to one per warranty term.

The Appliance must be installed according to all manufacturers' instructions as per the manual.

All Local and National required codes must be met.

The installer is responsible for ensuring the Appliance is operating as designed at the time of installation.

The original purchaser is responsible for the annual maintenance of the Appliance, as outlined in the owner's manual. As outlined below, the warranty may be voided due to problems caused by a lack of maintenance.

If freight damage has been found either externally or internally, the dealer must be informed within 3 days. All claims as a result of damage must be submitted by the dealer servicing the claim, including a copy of the Bill of Sale (proof of purchase). All claims must be complete and provide full details as requested by FPI to receive consideration for evaluation. **Incomplete claims may be rejected.**

As this is a **7-year** Limited Lifetime Warranty, if the Appliance needs to be replaced, the Appliance that was purchased at the time of sale might not be replaced with exactly the same model Appliance. In that case, FPI will replace your Appliance with one that is similar at the time of replacement under the terms of this Limited Lifetime Warranty, but **ONLY** in the event that an item covered by the Limited Lifetime Warranty is found to be defective. Please refer to the table on first page of this warranty for items covered by the Limited Lifetime Warranty. Product changes might be the result of the original Appliance being discontinued, changes in regulatory requirements, product advancements, etc., which are beyond the control of FPI. **This Limited Lifetime Warranty does not cover any installation costs, or costs associated with changes of required clearances for the replacement Appliance, hearth pads, mantles, facing and/or facing materials such as framing, completed walls made of drywall, wood, non-combustible board, tile, brick, stone, marble etc., venting/chimney systems, or components of the chimney system.**

If a suitable replacement is not available, FPI will refund **50%** of the purchase price of the Appliance and any applicable FPI accessories (faceplates, brick panels, media, etc.) purchased at the time of sale. **In no event will FPI refund any portion of the purchase price of, or reimburse costs associated with, any other items, including without limitation, installation of a new Appliance, changes of required clearances for a new Appliance, hearth pads, mantles, facing and/or facing materials such as framing, completed walls made of drywall, wood, non-combustible board, tile, brick, stone, marble etc., venting/chimney systems, or components of the chimney system. A copy of the receipt or bill of sale will be necessary to validate the purchase price.**

Purchased parts: Repair/replacement parts purchased by the consumer from FPI after the original coverage has expired on the Appliance will carry a **90-day** warranty from the purchase date, valid with a receipt only. Any item shown to be defective will be repaired or replaced at our discretion. No labor coverage is included with these parts.

Exclusions:

This Limited Lifetime Warranty does not extend to paint, rust or corrosion of any kind due to a lack of maintenance or improper venting, combustion air provision, corrosive chemicals (i.e. chlorine, salt, air, etc.), inner panels, door or glass gasketing, or any other additional factory fitted gasketing, color fading, carbon/sooting of the log sets due to use.

Malfunction, damage or performance based issues as a result of environmental conditions, location, chemical damages, downdrafts, installation error, an installation by an unqualified installer, incorrect chimney components (including but not limited to cap size or type), operator error, abuse, misuse, use of improper fuels (plastics, garbage, solvents,

cardboard, coal or coal products, oil-based products, waxed cartons, compressed pre-manufactured logs), lack of regular maintenance and upkeep, acts of God, weather-related problems from hurricanes, tornados, earthquakes, floods, lightning strikes/bolts or acts of terrorism or war, which result in a malfunction of the Appliance are not covered under the terms of this Limited Lifetime Warranty.

FPI has no obligation to enhance or modify any Appliance once manufactured (i.e. as products evolve, field modifications or upgrades will not be performed on existing Appliances).

This warranty does not cover dealer travel costs, mileage, fuel, tolls for diagnostic or service work. All labor rates paid to authorized dealers are subsidized, pre-determined rates. Dealers may charge you for travel and additional time beyond their subsidy.

Any Appliance showing signs of neglect or misuse will not be covered under the terms of this warranty policy and may void this warranty, including Appliances with rusted or corroded fireboxes that have not been reported as rusted or corroded within **three (3)** months of installation/purchase.

Appliances which show evidence of being operated while damaged, or with problems known to the purchaser and causing further damages will void this warranty.

Appliances where the serial no. has been altered, deleted, removed or made illegible will void this warranty.

Minor movement, expansion and contraction of the steel is normal and is not covered under the terms of this warranty.

Freight damages for products or parts are not covered under the terms of this warranty.

Products made or provided by other manufacturers and used in conjunction with the FPI Appliance without prior authorization from FPI may void this warranty.

Limitations of Liability:

The original purchaser's exclusive remedy under this warranty, and FPI's sole obligation under this Limited Lifetime Warranty, express or implied, in contract or in tort, shall be limited to replacement, repair, or refund, as outlined above. IN NO EVENT WILL FPI BE LIABLE UNDER THIS WARRANTY FOR ANY INCIDENTAL OR CONSEQUENTIAL COMMERCIAL DAMAGES OR DAMAGES TO PROPERTY. TO THE EXTENT PERMITTED BY APPLICABLE LAW, FPI MAKES NO EXPRESS WARRANTIES OTHER THAN THE WARRANTY SPECIFIED HEREIN. THE DURATION OF ANY IMPLIED WARRANTY IS LIMITED TO DURATION OF THE EXPRESSED WARRANTY SPECIFIED ABOVE. IF IMPLIED WARRANTIES CANNOT BE DISCLAIMED, THEN SUCH WARRANTIES ARE LIMITED IN DURATION TO THE DURATION OF THIS WARRANTY.

Some US states do not allow limitations on how long an implied warranty lasts, or allow exclusion or limitation of incidental or consequential damages, so the above limitations or exclusions may not apply to you.

Customers located outside the US should consult their local, provincial or national legal codes for additional terms which may apply to this warranty.

How to Obtain Warranty Service:

Customers should contact the authorized selling dealer to obtain warranty service. In the event the authorized selling dealer is unable to provide warranty service, please contact FPI by mail at the address listed below. Please include a brief description of the problem and your address, email and telephone contact information. A representative will contact you to make arrangements for an inspection and/or warranty service.

Canadian Warrantor:

**FPI Fireplace Products
International Ltd.**
6988 Venture St. Delta,
British Columbia Canada,
V4G 1H4

US Warrantor:

Fireplace Products U.S., Inc.
PO Box 2189 PMB 125
Blaine, WA
United States, 98231

Or contact the Regency Customer Care Centre at 1-800-442-7432 (phone) / 604-946-4349 (fax)
/customerservice@regency-fire.com (e-mail)

Product Registration and Customer Support:

Thank you for choosing a Regency Fireplace. Regency strives to be a world leader in the design, manufacture, and marketing of hearth products. To provide the best support for your product, we request that you complete a product registration form at <http://www.regency-fire.com/Customer-Care/Warranty-Registration.aspx> within **ninety (90)** days of purchase.

Warranty Registration Card



Product Registration and Customer Support:

Thank you for choosing a Regency Fireplace. Regency strives to be a world leader in the design, manufacture, and marketing of hearth products. To provide the best support for your product, we request that you complete a product registration form found on our Web Site under Customer Care within ninety (90) days of purchase.

For purchases made in **CANADA or the UNITED STATES:**

<http://www.regency-fire.com/Customer-Care/Warranty-Registration.aspx>

For purchases made in AUSTRALIA:

<http://www.regency-fire.com.au/Customer-Care/Warranty-Registration.aspx>

You may also complete the warranty registration form below to register your Regency Fireplace Product and mail and/or fax it back to us, and we will register the warranty for you. It is important you provide us with all the information below in order for us to serve you better.

Warranty Registration Form (or Register online immediately at the above Web Site):

Warranty Details	
Serial Number (required):	
Purchase Date (required) (mm/dd/yyyy):	
Product Details	
Product Model (required):	
Dealer Details	
Dealer Name (required):	
Dealer Address:	
Dealer Phone #:	
Installer:	
Date Installed (mm/dd/yyyy):	
Your Contact Details (required)	
Name:	
Address:	
Phone:	
Email:	

For purchases made in CANADA:

FPI Fireplace Products International Ltd.
6988 Venture St.
Delta, British Columbia
Canada, V4G 1H4

Phone: 604-946-5155
Fax: 1-866-393-2806

For purchases made in the UNITED STATES:

Fireplace Products US, Inc.
PO Box 2189 PMB 125
Blaine, WA
United States, 98231

Phone: 604-946-5155
Fax: 1-866-393-2806

For purchases made in AUSTRALIA:

Fireplace Products Australia Pty Ltd
99 Colemans Road
Dandenong South, Vic.
Australia, 3175

Phone: +61 3 9799 7277
Fax: +61 3 9799 7822

For fireplace care and tips and answers to most common questions please visit our Customer Care section on our Web Site. Please feel free to contact your selling dealer if you have any questions about your Regency product.

Installer: Please complete the following information

Dealer Name & Address: _____

Installer: _____

Phone #: _____

Date Installed: _____

Serial #: _____