

DIAGRAM 1

TOOLS REQUIRED FOR ASSEMBLY:
ADJUSTABLE WRENCH OR 13MM WRENCH OR EQUIVALENT

HARDWARE

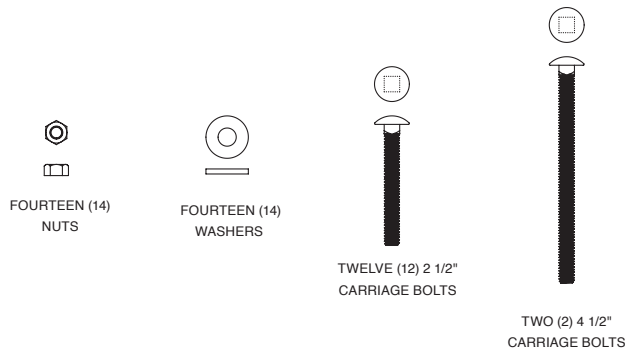

DIAGRAM 2

SUB-ASSEMBLIES

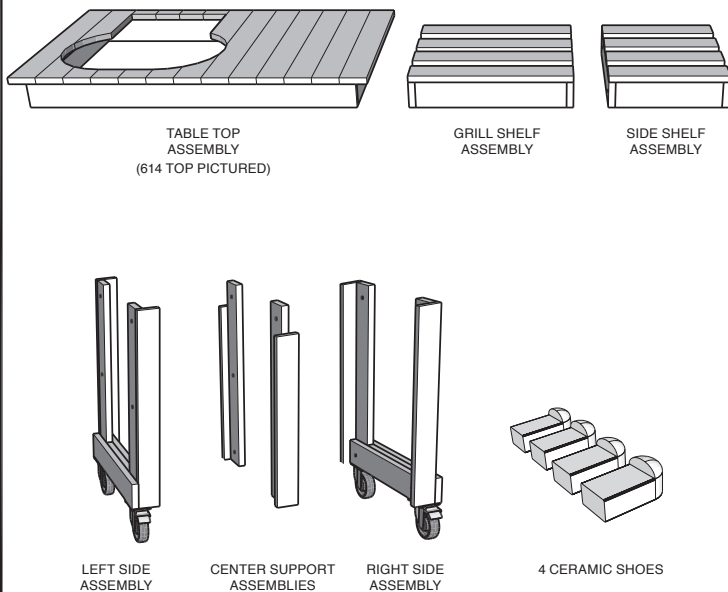
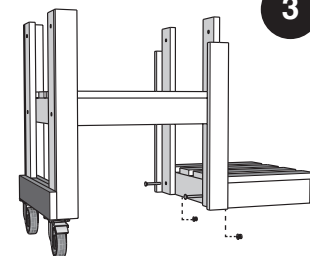
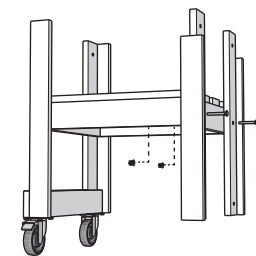
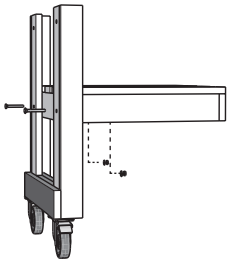
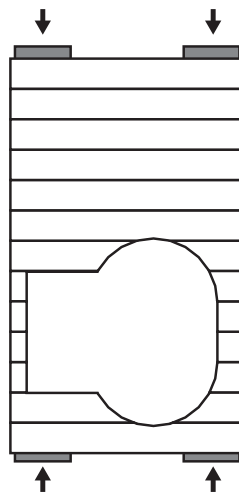

DIAGRAM 3



ASSEMBLY INSTRUCTIONS

Hardware bags are attached to the underside of bottom shelves.



There are 4 blocks of wood attached to the ends of the Table Top Assembly. These blocks are for shipping purposes and should be carefully removed from the Table Top Assembly.

There are 2 different leg assemblies which must be placed in the correct position. Place the leg assemblies so the locking casters face front of the table.

1. Find the Grill Shelf Assembly and attach to the Left Side Assembly (bottom hole is approximately 9" from caster) with 2 1/2" carriage bolts, washers, and nuts.
2. Attach Center Support Assemblies with three holes (this assembly is 2 separate pieces) to the other end of shelf using middle hole with 2 1/2" carriage bolts, washers, and nuts.
3. Attach the Side Shelf Assembly to same Center Support Assembly using bottom holes and the 2 1/2" bolts, washers and nuts.
4. Attach the Right Side assembly to opposite end of the Side Shelf Assembly with 4 1/2" bolts, nuts and washers. Snug nuts hand tight at this point. Stand table upright.
5. Place Table Top Assembly on top of legs aligning holes in the cross support boards using 2 1/2" bolts, nuts, and washers. Make sure the hole in the top of the table is above Grill Shelf Assembly. Tighten all nuts until bolt heads start to impact wood.
6. Align 4 Ceramic Shoes as shown on the Grill Shelf. Protect the table top with towels or cardboard from the carton and carefully lower Primo Ceramic Grill into place. Adjust Ceramic feet as necessary for best stability.

CARE INSTRUCTIONS

We want to make sure your table stays beautiful and distinctive throughout the years.

To properly care for your table, please make sure to use a standard sealant (Marine or Spar Varnish). This product is available at most paint or hardware stores. The first application should be more than one coat. The more coats the better you will protect your table. NOTE: STAIN IS NOT a sealant. Reseal as needed in the future.

If lifting the table, DO NOT lift your table by the top shelf.

4

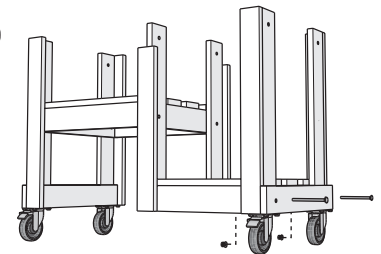

5

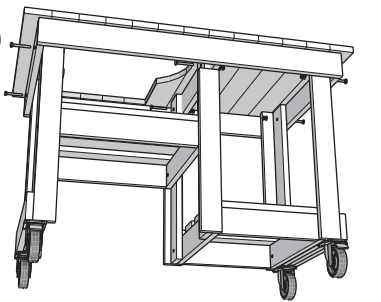

6

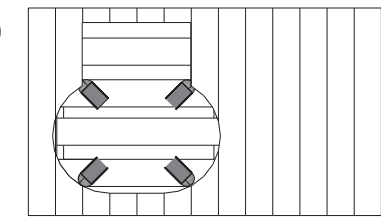

FINISHED ASSEMBLY (614 TABLE PICTURED)

