

STÛV 6-IN

INSTALLATION MANUAL

Keep these instructions for future reference

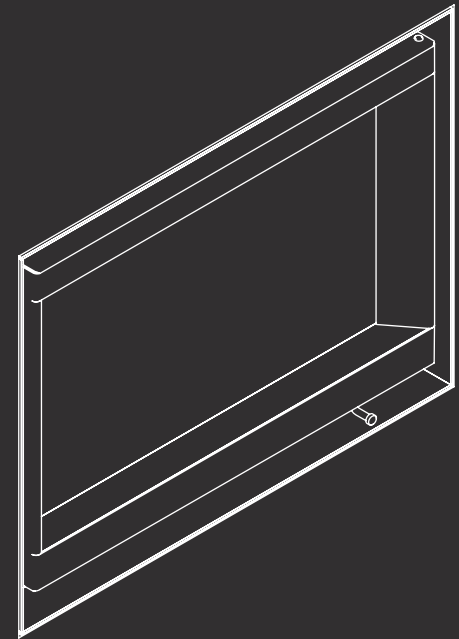
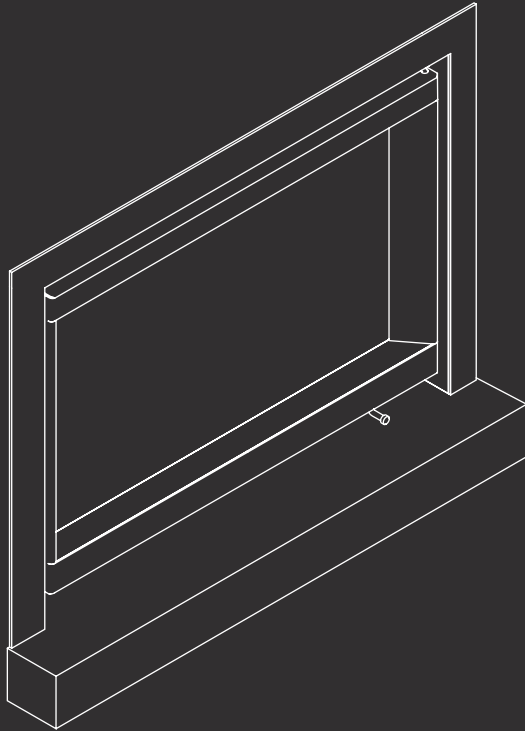

REQUIRED TOOLS



Impact drill



Hammer



Crowbar



Level



Measuring tape



Cutting pliers



Pliers



Flat screwdriver



Grinder

REQUIRED HARDWARE



Torx 20 bit



Torx 25 bit



Torx 30 bit



7 mm hex socket



8 mm hex socket



10 mm hex socket



No. 2 square bit



5 mm hex bit

REQUIRED MATERIAL



Stuv handles



Protective fabric or cardboard

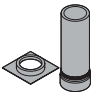

Chimney kit (flexible or rigid)



Ø4" clamping collar and flexible duct (option)

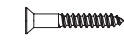

No. 8 wood screw



No. 10 concrete screw

ADDITIONAL MANUALS

Thank you for choosing a Stûv fireplace! It has been designed to offer maximum pleasure, comfort and safety. The utmost care has been taken in manufacturing this product. If, despite this, you should still find a flaw, please contact your dealer.

This manual explains how to carry out a standard installation of a Stûv 6 unit. To install a frame, an air damper or any other option, it is necessary to respect, when applicable, certain particularities that are outlined in the additional manuals provided. If the additional manuals are missing, contact customer service and request the necessary instruction manual(s), mentioning the code(s) under the icons below.

Look for these symbols. They signal a change from the standard installation. It is very important to skim through the appliance manual and additional manuals before starting and to follow the instructions closely during installation to ensure no steps are omitted.

Keep all instruction manuals provided close at hand to have all the information needed and to ensure proper and safe installation.



AIR DAMPER
9310400019

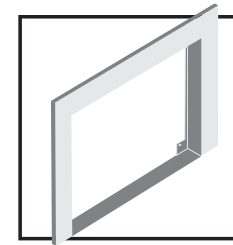

PICTURE TYPE FRAME
9310400023

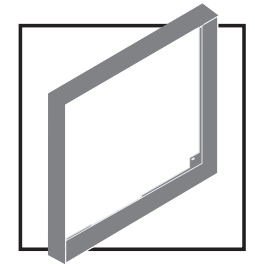

THIN EDGE FRAME
9310400024



IMPORTANT

Before installing this Stûv unit, contact the local authorities and/or your insurance company to obtain a building permit and inquire about all the requirements that need to be met.

For information on all the applicable regulatory requirements, contact your local fire department before starting the installation.

TABLE OF CONTENTS

1. CERTIFICATION 4



- 1.1 Certification 5
- 1.2 Technical Specifications 5
- 1.3 Marking Label 6
- 1.4 Safety Instructions 7

2. COMPONENTS 8



- 2.1 List of Components 9
- 2.2 Frames 11
- 2.3 Optional Kits 12

3. DIMENSIONS 13



- 3.1 Overall Dimensions 14
- 3.2 Dimensions of the Connectors 15
- 3.3 Dimensions of the Opening 16
- 3.4 Non-Combustible Materials 17
- 3.5 Risk Area 19
- 3.6 Convection Air 19
- 3.7 Combustion Air 20

4. INSTALLATION 21



- 4.1 Combustion 22
- 4.2 Unpacking and Moving 23
- 4.3 Disassembly 24
- 4.4 Connection to the Combustion
Air Intake 26
- 4.5 Reassembly and Chimney 28
- 4.6 Adjusting the Door 31

5. CHIMNEY 32



- 5.1 Dimensions and Certification 33
- 5.2 Typical Installation 33
- 5.3 Connection to a Chimney Pipe 34

6. USE 35



- 6.1 Wood Selection 36
- 6.2 Safety 37
- 6.3 Door Handling 38
- 6.4 Starting the Fire 38
- 6.5 Reloading the Fire 40
- 6.6 Ash Removal 40

7. MAINTENANCE 41



- 7.1 Glass and Seals 42
- 7.2 Creosote and Chimney-Sweeping 42
- 7.3 Component Replacement 43

8. WARRANTY 45



- 8.1 Warranty Details 46
- 8.2 Warranty Form 47

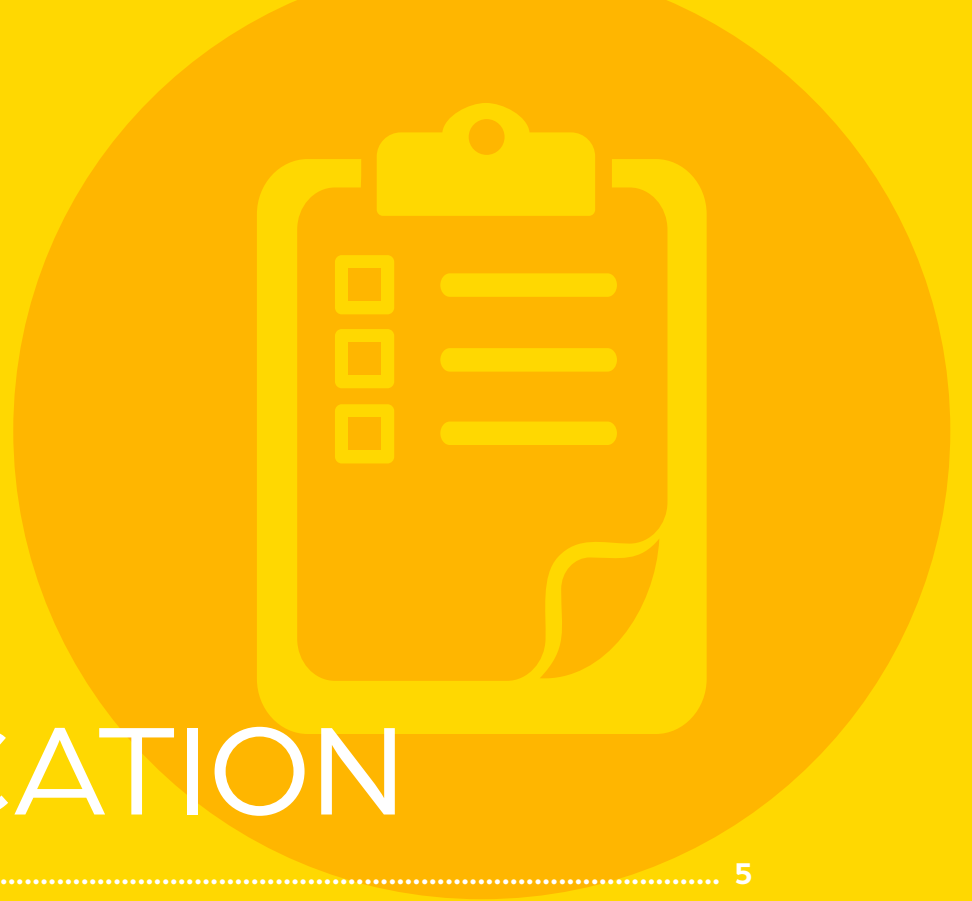

1

CERTIFICATION

1.1	CERTIFICATION	5
1.2	TECHNICAL SPECIFICATIONS	5
1.3	MARKING LABEL	6
1.4	SAFETY INSTRUCTIONS	7

1.1 CERTIFICATION



Tested and certified by CSA
as for standard:

ULC-S628-93 & UL 1482 - 7th Edition

EPA 2020 CRIB WOOD
ASTM E2780; ASTM E2515 methods 28R as referenced
in CFR EPA Title 40, Part 60, Subpart AAA

CSA B415.1-10

Before installing and using this Stûv unit, read this entire manual and contact the local authorities to obtain a building permit. Take note of all applicable regulatory requirements.

This unit must be installed by a qualified professional. Improper installation could result in a fire.

The instructions for the installation of this wood-burning fireplace comply with the above-mentioned standards. They must be closely followed to eliminate the risk of serious problems.

Do not install the fireplace in a mobile home. Do not connect the fireplace to a hot air distribution system.

To reduce the risk of fire, read this manual carefully before installing or using the fireplace. If the installation instructions are not followed and the fireplace is improperly installed, the risk of an incident occurring increases. This can result in fire, property damage, bodily injury and even death.

Keep these instructions for future reference.



NOTE

We strongly recommend that our products be installed and maintained by professionals certified by the Association des Professionnels du Chauffage if you are in Quebec or by Wood Energy Technical Training for the rest of Canada, and by the National Fireplace Institute in the United States.



1.2 TECHNICAL SPECIFICATIONS



STÛV 6	66x50	76x55	76x60
Average particulate emission rate in g/h (output)	1.93 g/h	1.86 g/h	1.89 g/h
Average particulate emission rate in g/MJ (output)	0.177 g/MJ	0.084 g/MJ	0.079 g/MJ
1st hour Emission rate	3,85 g/h	4,02 g/h	4,03 g/h
Average efficiency of the appliance (%)	68.4%	67.6%	68.25%
Minimum heat output rate (BTU/h)	14 802 *	20 473 **	22 079 ***
Maximum heat output rate (BTU/h)	17 121 *	21 732 **	23 388 ***
Max. log length	16"	20"	20"
Weight	165 lb.	190 lb.	200 lb.
Combustion chamber volume	1.08 pi ³	1.55 pi ³	1.58 pi ³
Wood consumption/H	2.7 lb/h	3.7 lb/h	3.9 lb/h
Tested fuel	Crib wood		

This manual describes the installation and operation of the Stûv 6-in wood heater. This heater meets the 2020 U.S. Environmental Protection Agency's crib wood emission limits for wood heaters sold after May 15, 2020.

* Under specific test conditions this heater has shown to deliver heat at rates ranging from 14 802 to 17121 Btu/hr.

** Under specific test conditions this heater has shown to deliver heat at rates ranging from 20 473 to 21 732 Btu/h.

*** Under specific test conditions this heater has shown to deliver heat at rates ranging from 22 079 to 23 388 Btu/hr.

United States Design Patent No. US D898,173 S



ATTENTION!

CHAUD LORSQU'EN FONCTION.
GARDER LES ENFANTS,
VÊTEMENTS ET MEUBLES HORS
DE PORTÉE. TOUCHER L'APPAREIL
POURRAIT CAUSER DES
BRÛLURES. VOIR LA FICHE
SIGNALÉTIQUE ET INSTRUCTIONS.



CAUTION!

HOT WHILE IN OPERATION DO
NOT TOUCH, KEEP CHILDREN,
CLOTHING AND FURNITURE AWAY.
CONTACT MAY CAUSE SKIN
BURNS. SEE NAME-PLATE AND
INSTRUCTIONS.

CERTIFIED AND CONFORMS TO / CERTIFIÉ ET CONFORME SELON:
ULC-S6450-03 | UL 1482-7th Edition | EPA 2020 CBH/VOC | CSA B415.1-10
ASTM E2780 | ASTM E2515 methods 2B/3 as referenced in CFR EPA Title 40, Part 60, Subpart AAA
6-in 66x50; 183 g/h (EPA 2020) | 76x55; 186 g/h (EPA 2020) | 76x60; 189 g/h (EPA 2020)

LISTED FACTORY BUILT STOVE FOR USE IN CANADA AND THE U.S.A.

NOT SUITABLE FOR MOBILE HOME INSTALLATION
NE PAS INSTALLER DANS UNE MAISON MOBILE

U.S. ENVIRONMENTAL PROTECTION AGENCY

Certified to comply with 2020 particulate emission standards for single burn rate heaters.
This single burn rate wood heater is not approved for use with a flue damper.

AGENCE DE PROTECTION DE L'ENVIRONNEMENT - U

Conforme aux standards d'émissions pour foyers à combustion à vitesse constante 2020. Ce foyer à
vitesse de combustion constante n'est pas approuvé pour utilisation avec un clapet de fumée.

CHEMNEY TYPE (see manual for appropriate choice)

Use rigid or flexible liner. Use only a 6" or 7" liner listed per UL 1777; ULC-S635 ou ULC-S640.

TYPE DE CHEMINÉE (voir le manuel d'instruction pour les bons choix)

Utilisez une gaine rigide ou flexible. Utilisez seulement une gaine de 6" ou 7" certifiée
selon les normes UL 1777, ULC-S635 ou ULC-S640.

- Combustible: Bois de corde seulement.
- Ce foyer peut avoir été traité pour accueillir un encastrement. Il doit être remis dans son état d'origine avant utilisation.
- Se référer au code du bâtiment local pour le prolongement de l'âtre.
- Pour un fonctionnement sécuritaire et conformément aux règlements fédéraux, suivre la notice d'installation et le mode d'emploi de Stûv America.
- Ne pas utiliser l'appareil les portes ouvertes et charger seulement au feu ouvert.
- Les composants utilisés dans l'appareil doivent être répertoriés. Voir la notice d'installation.
- Communiquer avec les autorités locales en matière de construction ou d'incendie avant d'installer l'appareil.
- Ne pas chauffer au point où des parties deviennent rougeoyantes.
- Ne pas réfer cet appareil à un conduit de cheminée servant un autre appareil.
- Inspecter et nettoyer la cheminée fréquemment - Dans certaines conditions d'utilisation, l'accumulation de cendre peut se faire rapidement. Inspecter et nettoyer la cheminée fréquemment.
- Ne pas utiliser de cheminé. Ne pas surlever le feu. Brûler le bois directement au fond de l'âtre.
- Cet insert a besoin d'inspection et d'entretien périodiques pour sa bonne utilisation.
- Consultez le manuel d'utilisation pour les instructions relatives à l'entretien et aux contrôles au manuel d'utilisation pour les instructions relatives à la sécurité.
- **ATTENTION:** Pièces chaudes. Ne pas faire fonctionner avec le clapet retiré.

MODELS/MODÈLES :
STÛV 6-in 66x50, 76x55, 76x60

MANUFACTURED BY / FABRIQUE PAR:
Stûv America 34, Boul. de l'Amérique

Bromont QC Canada J2L 1S6 (stuvamerica.com)

DATE OF MANUFACTURE / DATE DE FABRICATION	JAN	FEB	MAR	APR
2023	MAY	JUN	JUL	AUG
2024	SEP	OCT	NOV	DEC

LABEL NO. / NO. D'ÉTIQUETTE:
STÛV 6_000 000



- Fuel: Cord wood Only.
- This fireplace has been altered to accommodate a fireplace insert and is not suitable for use with a conventional fireplace.
- Refer to local building code for hearth extension dimensions.
- For safe operation, install and use only in accordance with Stûv America's instructions.
- Replace glass only with Stûv's ceramic glass 4mm thick.
- Do not operate unit with doors open and load on open fire door.
- Components used with fireplace must be listed. See owners manual.
- Contact your local building or fire officials about restrictions, and obtain any necessary permits.
- Do not overfire - If stove or chimney connector gloves, you are overfiring.
- Do not connect this unit to a chimney flue serving another appliance.
- Inspect and clean chimney frequently - Under certain conditions of use, creosote buildup may occur rapidly. Inspect and repair wood heater for creosote buildup.
- Do not use grate or elevate fire. Build wood fire directly on hearth.
- This wood heater needs periodic inspection and repair for proper operation. Consult the owner's manual for further information. It is important to have a professional inspect and repair the chimney after persistent with the operating instructions in the owner's manual.
- **CAUTION:** Hot parts. Do not operate unit with damper removed.

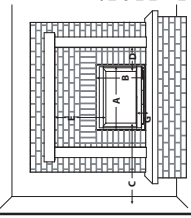

The minimum clearances indicated below are from the glass and for all types of combustible materials (e.g., wood, drywall, etc.).
Les dégagements minimaux indiqués ci-dessous sont à partir de la vitre et pour tous matériaux combustibles (ex.: bois, gypse, etc.).

A: 66x50: 26" 76x55: 29 1/4" 76x60: 29 1/4"
B: 66x50: 19 1/4" 76x55: 21 1/4" 76x60: 23 1/4"
C: 66x50: 16" 76x55: 16" 76x60: 16"
D: 20 1/2" pour une tablette de 8" ou TV

For more details, consult the installation manual / Pour plus de détails, consulter la notice d'installation

STÛV 6	66x50	76x55	76x60
Average particulate emission rate in g/h and g/MJ (output)	103 g/h 0.1779 g/MJ	186 g/h 0.084 g/MJ	180 g/h 0.079 g/MJ
Emission particules fines moyenne en g/h et g/MJ (sortie)	68.4%	67.6%	68.25%
Average efficiency of the appliance (%)	68.4%	67.6%	68.25%
Rendement moyen de l'appareil (%)	14,802	20,473	22,079
Minimum heat output rate (BTU/h)			
Puissance minimum (BTU/h)	17,21	21,732	23,388
Maximum heat output rate (BTU/h)			
Puissance maximum (BTU/h)			

DO NOT REMOVE THIS LABEL / NE PAS RETIRER CETTE ÉTIQUETTE

This Stûv fireplace must be registered to be covered by the warranty. Please refer to the last section of this document for guidance.

The self-adhesive marking label and the riveted label with the serial number are located in the drawer under the combustion chamber. They contain all the information needed to register this product.

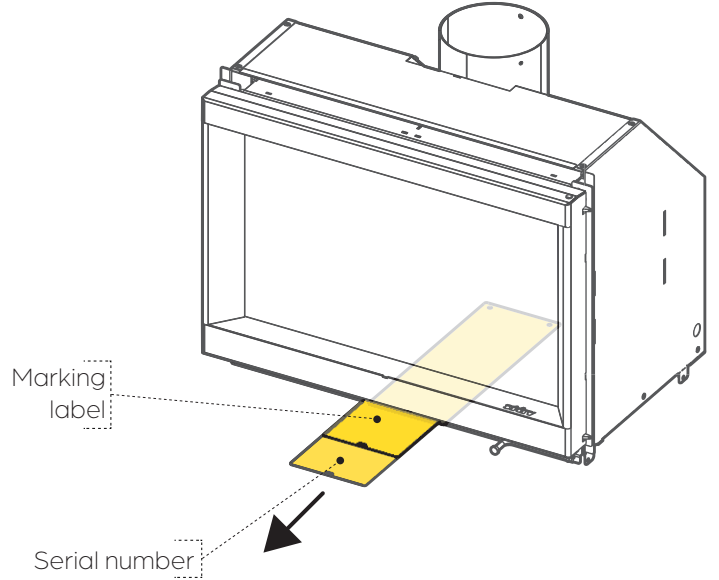



WARNING

1. It is essential that the installation of this Stûv be carried out by a qualified professional. For all applicable regulatory requirements, contact the local fire department before beginning work.
2. The instructions for the installation of this unit comply with the abovementioned standards. They must be closely followed to eliminate the risk of serious problems. Any use contrary to the user manual is a violation of federal law.
3. Improper installation of this Stûv unit could result in a fire. To reduce the risk of fire, follow the installation instructions to the letter. Failure to follow the instructions in this manual may result in property damage, bodily injury or death.
4. This wood heater needs periodic inspection and repair for proper operation. (minimum three times during the heating season). It is against federal regulations to operate this wood heater in a manner inconsistent with operating instruction in this manual.
5. Any modifications made to this unit may pose a hazard and will void the warranty. Should repairs be necessary, use only Stûv replacement parts.
6. Combustible materials such as firewood, wet clothing, etc. placed too close to the unit could catch fire.
7. We recommend storing solid fuels in a clean, dry environment. Do not place this type of fuel within the risk area or in the loading/ash removal area.
8. Never leave the fireplace unattended when the door is open.
9. Always close the door after the ignition period.
10. Open the door only to reload the fire.
11. Do not burn garbage, plastic, petroleum-based materials, gasoline, rubber, industrial solvents, flammable liquids such as naphtha and motor oil, paper, cardboard, wood extracted from salt water and dried, painted wood or any substance that emit dense fumes and strong odours.
12. Make sure the home is equipped with a smoke and carbon monoxide detector.
13. Do not connect this appliance to a chimney pipe serving another appliance.
14. This unit is hot when in use. Keep children, clothing and furniture at a safe distance. Touching the appliance while it is in operation may cause burns.
15. Some parts of the fireplace can be very hot when operated at rated capacity.
16. Do not allow the fireplace to heat to the point where parts become red.
17. Do not use a grate or other methods to elevate the fuel. Burn firewood directly on the firebricks.
18. Do not overheat the unit. Attempting to exceed the single burn rate of this unit may permanently damage it.
19. Conduct regular maintenance of the fireplace as previously recommended.
20. Never use chemicals or other liquids such as gasoline, gasoline-based lantern fuel, kerosene, charcoal liquid, or similar liquids to start or feed a fire in the fireplace. Keep all such liquids away from the unit while it is in operation.
21. Do not install this unit in a trapotation building or a mobile home.
22. The air inlets and outlets must remain free of obstacles at all times.
23. The installation of the unit must comply with all local and national regulations.
24. Inspect and sweep the chimney frequently. In certain operating conditions, creosote can build up quickly. Inspect and repair the insert to ensure proper operation.
25. Objects placed in front of the unit must be kept at a distance of at least 48" (4') from the unit's glass face.
26. This wood heater has a manufacturer-set minimum low burn rate that must not be altered. It is against federal regulations to alter this setting or otherwise operate this wood heater in a manner inconsistent with operating instructions in this manual.

2

COMPONENTS

2.1	LIST OF COMPONENTS	9
2.2	FRAMES	11
2.3	OPTIONAL KITS	12



2.1 LIST OF COMPONENTS

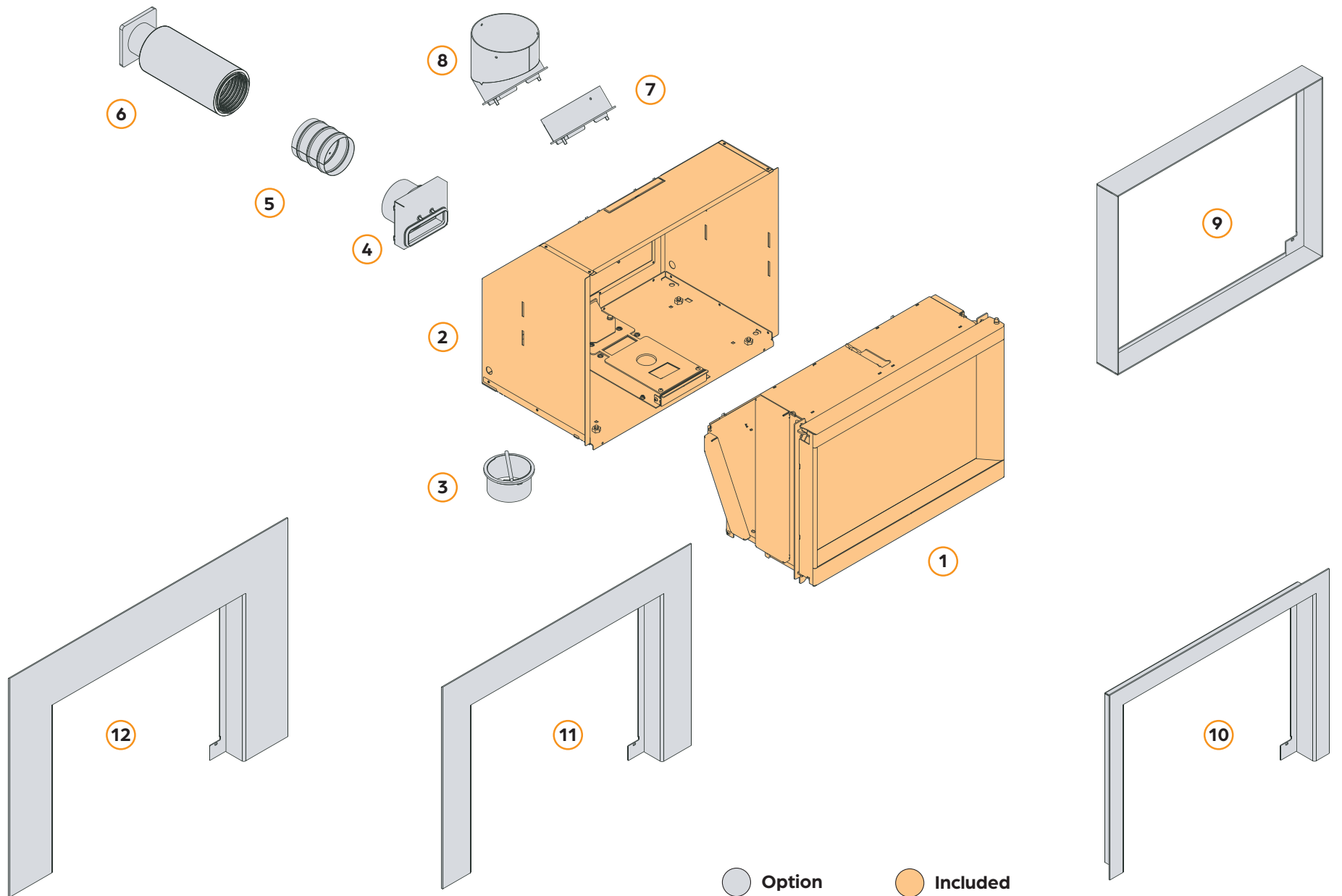

2.1 LIST OF COMPONENTS



66x50

FW1000600101

#	DESCRIPTION	PRODUCT CODE	INCLUDED OR OPTION	Q ^{TY}
1	Fireplace	N/A	Included	1
2	Support casing	N/A	Included	1
9	Thin edge frame	AW1100600101	Required option	1
10	2" picture type frame	AW1100600712		
11	4" picture type frame	AW1100600714		
12	6" picture type frame	AW1100600716		

76x55

FW1000600201

#	DESCRIPTION	PRODUCT CODE	INCLUDED OR OPTION	Q ^{TY}
1	Fireplace	N/A	Included	1
2	Support casing	N/A	Included	1
9	Thin edge frame	AW1100600201	Required option	1
10	2" picture type frame	AW1100600812		
11	4" picture type frame	AW1100600814		
12	6" picture type frame	AW1100600816		

76x60

FW1000600701

#	DESCRIPTION	PRODUCT CODE	INCLUDED OR OPTION	Q ^{TY}
1	Fireplace	N/A	Included	1
2	Support casing	N/A	Included	1
9	Thin edge frame	AW1100602401	Required option	1
10	2" picture type frame	AW1100602612		
11	4" picture type frame	AW1100602614		
12	6" picture type frame	AW1100602616		

ACCESSORIES

#	DESCRIPTION	PRODUCT CODE	INCLUDED OR OPTION	Q ^{TY}
3	Outside air intake connector - from underneath	AW1200202400	Option	1
4	Outside air intake connector - from back	AW1200206700	Option	
5	4" air damper	AW1200100300	Option	1
6	Outside air intake kit	AW1200200001	Option	1
7	45° - 6" smoke outlet connector	AW1202000000	Required option	1
	45° - 7" smoke outlet connector	AW1202000001		
8	90° - 6" smoke outlet connector	AW1202000100		
	90° - 7" smoke outlet connector	AW1202000101		

2.2 FRAMES (REQUIRED OPTION)



THIN EDGE FRAME

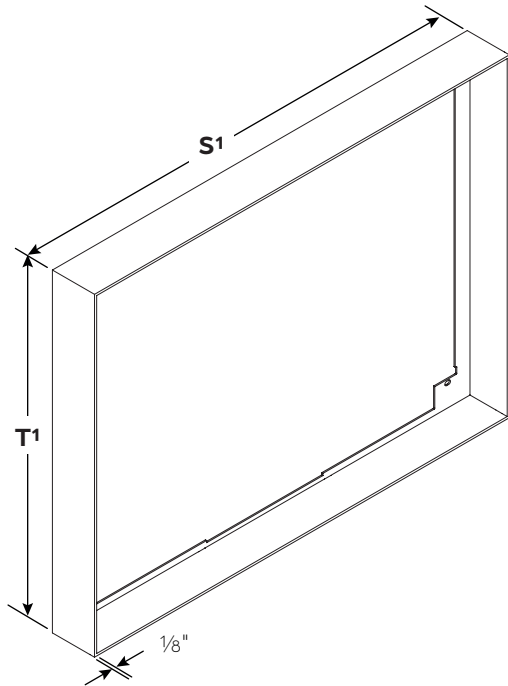

Thin edge	CODE	S ¹	T ¹
66x50	AW1100600101	26"	19 11/16"
76x55	AW1100600201	29 15/16"	21 11/16"
76x60	AW1100602401	29 15/16"	23 5/8"

PICTURE TYPE FRAME

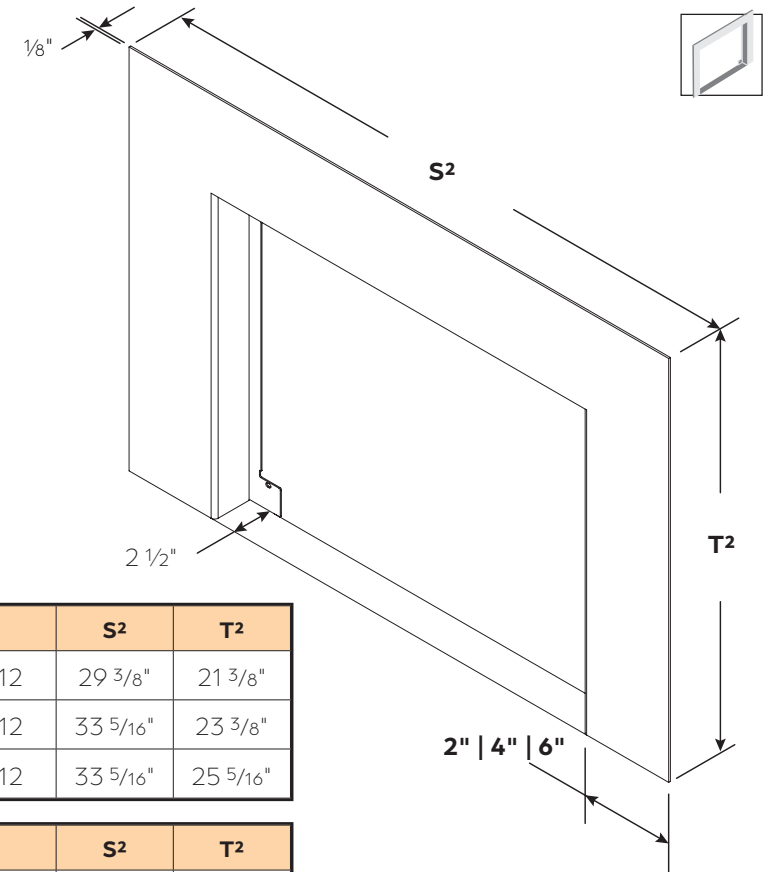

2"	CODE	S ²	T ²
66x50	AW1100600712	29 3/8"	21 3/8"
76x55	AW1100600812	33 5/16"	23 3/8"
76x60	AW1100602612	33 5/16"	25 5/16"

4"	CODE	S ²	T ²
66x50	AW1100600714	33 5/16"	23 3/8"
76x55	AW1100600814	37 1/4"	25 5/16"
76x60	AW1100602614	37 1/4"	27 5/16"

6"	CODE	S ²	T ²
66x50	AW1100600716	37 1/4"	25 5/16"
76x55	AW1100600816	41 3/16"	27 5/16"
76x60	AW1100602616	41 3/16"	29 1/4"

2.2 OPTIONAL KITS (NOT INCLUDED)



OUTSIDE AIR INTAKE CONNECTORS

Installation p.23, 27 and 28

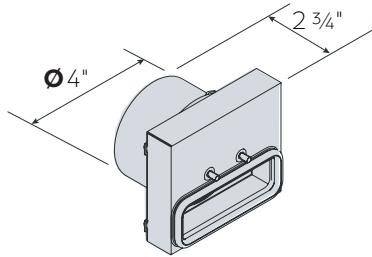

FROM BACK
AW1200206700

FROM UNDERNEATH
AW1200102400

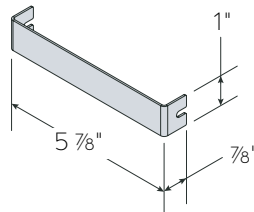
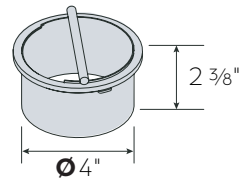

SMOKE OUTLET CONNECTORS

Installation p.23 and 30

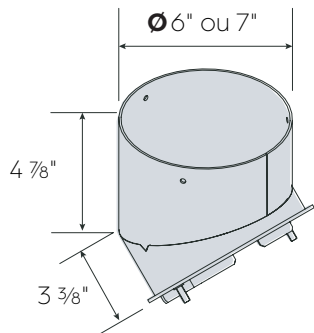

VERTICAL | 90°

- Ø 6" AW1202000100
- Ø 7" AW1202000101

ANGLED | 45°

- Ø 6" AW1202000000
- Ø 7" AW1202000001

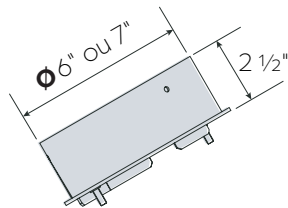

AIR DAMPER

For outside air intake

Follow the instructions supplied with the air damper.

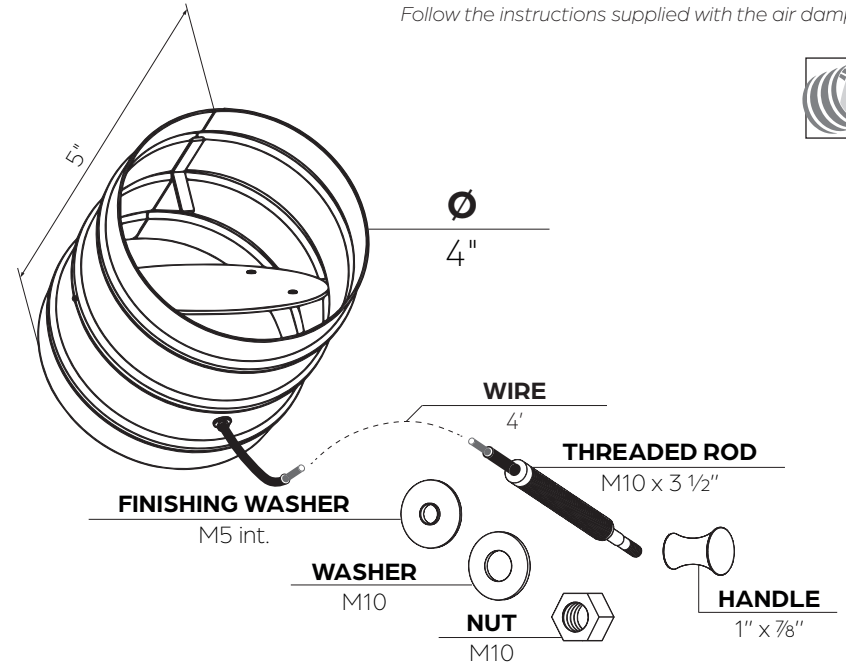

OUTSIDE AIR KIT

Follow the instructions supplied with the air damper.

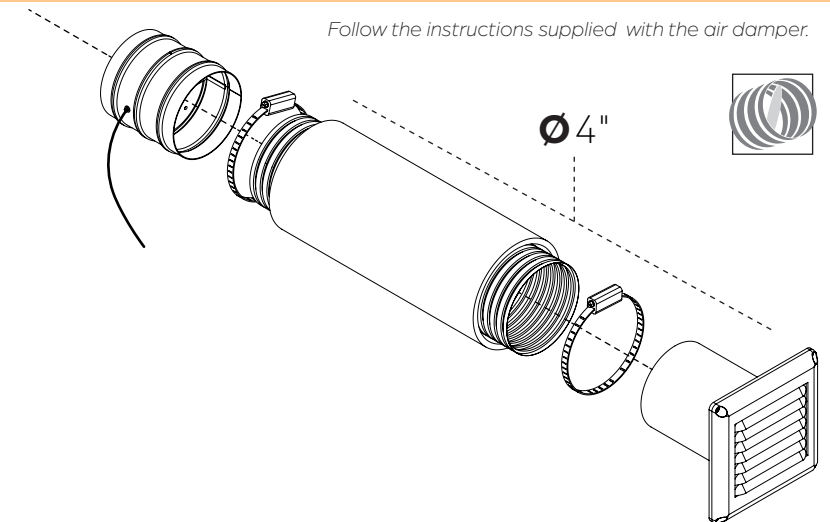

3

DIMENSIONS

3.1	OVERALL DIMENSIONS	14
3.2	DIMENSIONS OF THE CONNECTORS	15
3.3	DIMENSIONS OF THE OPENING	16
3.4	NON-COMBUSTIBLE MATERIALS	17
3.5	RISK AREA	19
3.6	CONVECTION AIR	19
3.7	COMBUSTION AIR	20

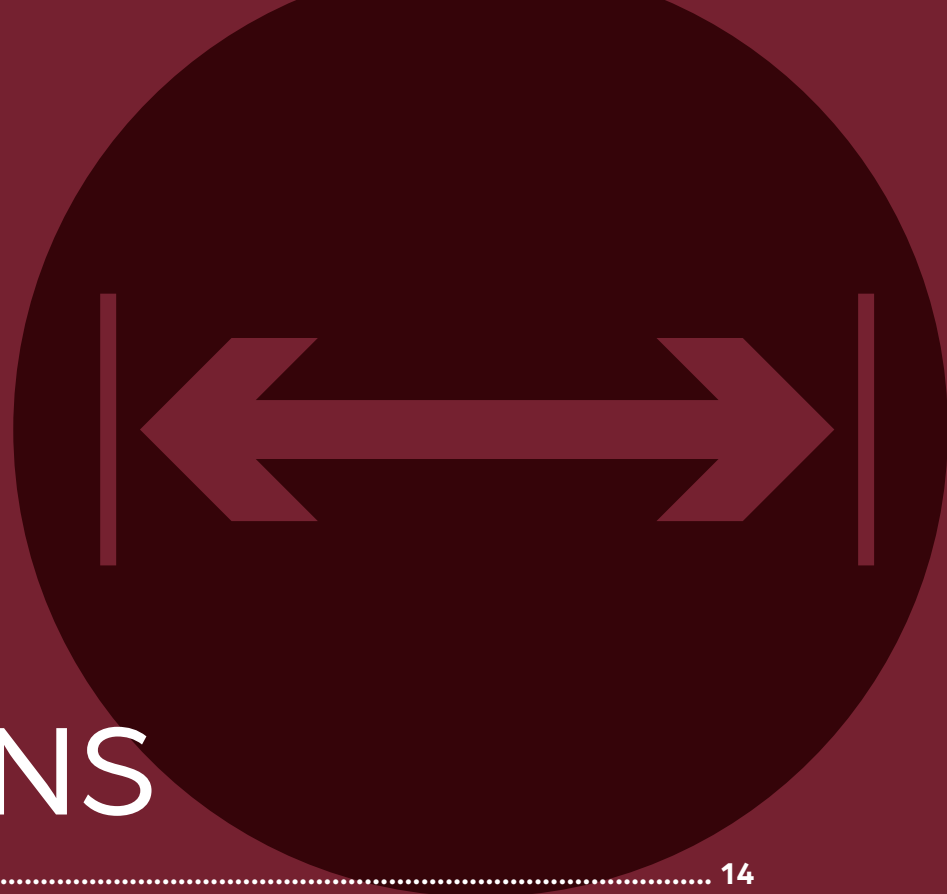

3.1 OVERALL DIMENSIONS



MODEL	A	B	C	D	E	F	G	J
66x50	24 1/2"	23 1/4"	24 1/8"	12 1/16"	16 3/4"	19 1/4"	11 7/16"	20 9/16"
76x55	28 7/16"	27 1/4"	28 1/16"	14 1/16"	18 3/4"	21 1/4"	13 3/8"	24 1/2"
76x60	28 7/16"	27 1/4"	28 1/16"	16 1/16"	20 3/4"	23 3/16"	15 3/8"	24 1/2"

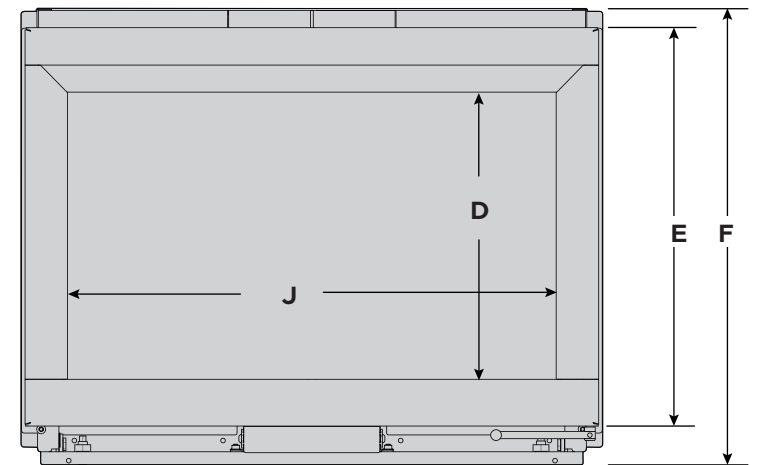
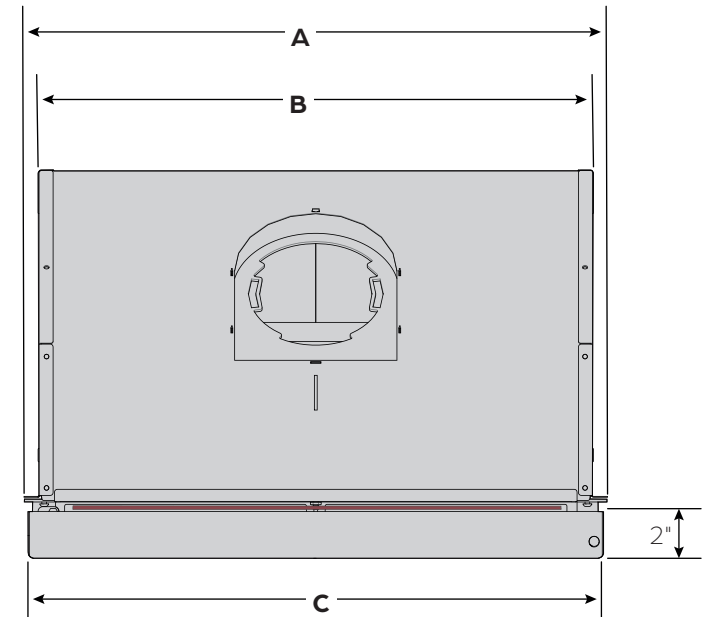
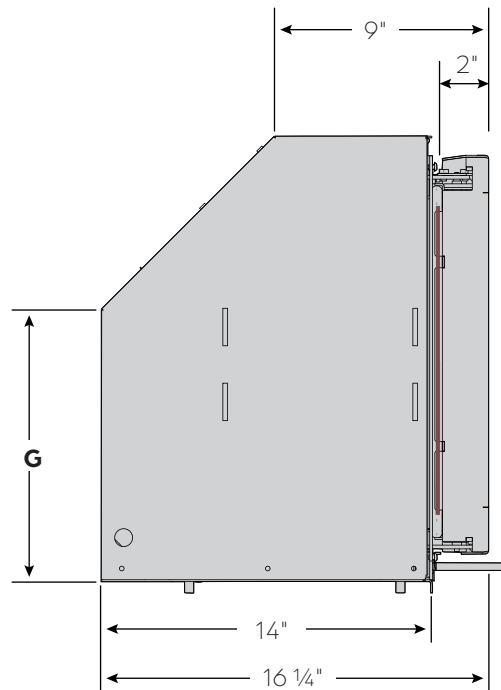

3.2 DIMENSIONS OF THE CONNECTORS



SMOKE OUTLET AT 90°

Installation p.23 et 30

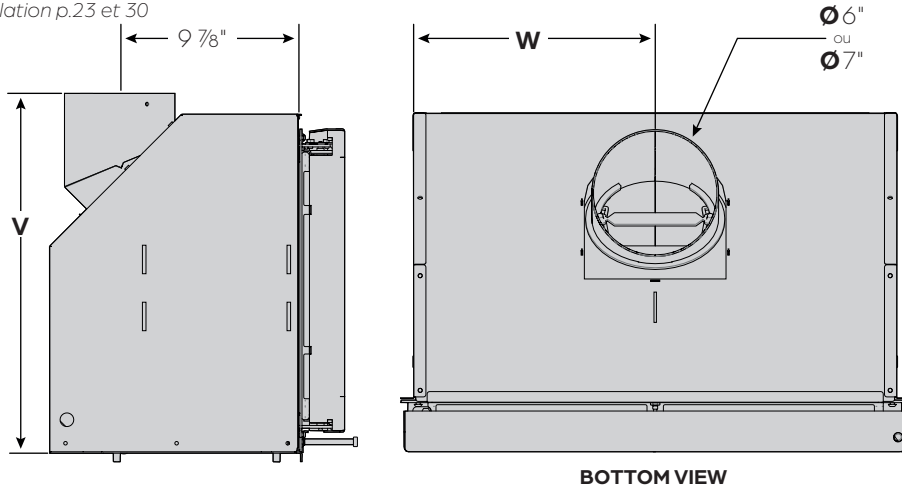

SMOKE OUTLET AT 45°

Installation p.23 et 30

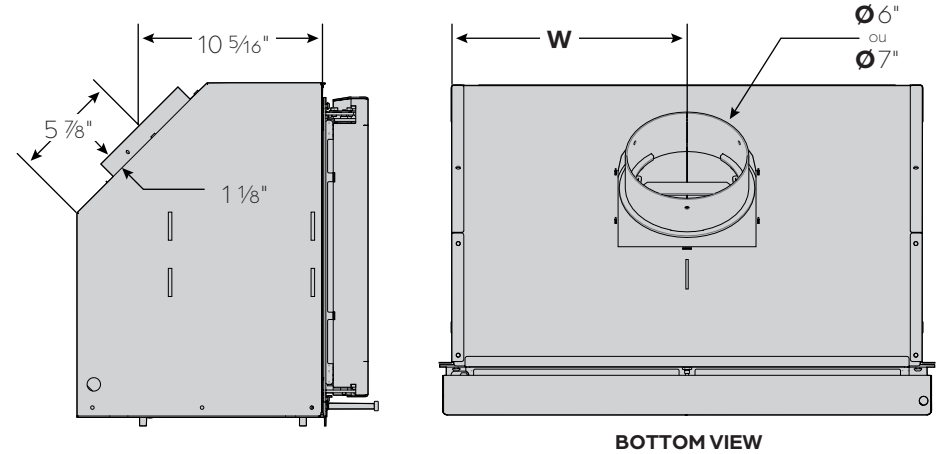

MODEL	V	W
66x50	19 5/8"	11 5/16"
76x55	21 7/8"	13 5/8"
76x60	23 7/8"	13 5/8"

! CAUTION

These are the dimensions of the unit. See next page for the masonry hearth dimensions.

OUTSIDE AIR INTAKE - FROM UNDERNEATH

Installation p.23 et 27

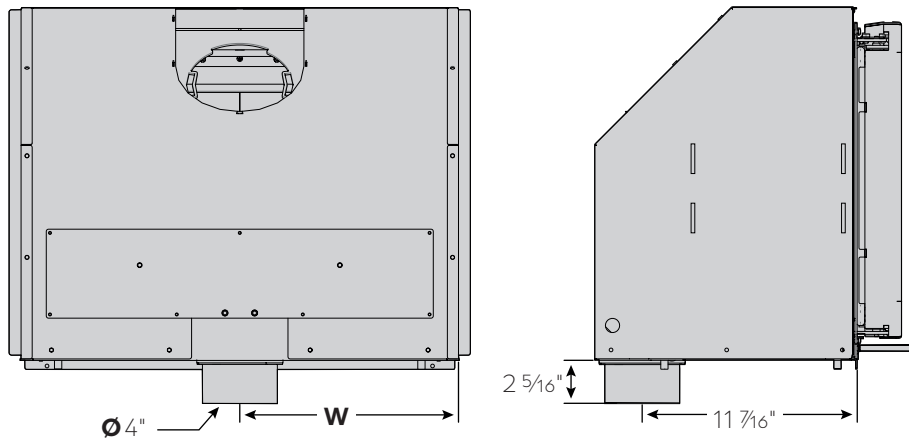

OUTSIDE AIR INTAKE - FROM BACK

Installation p.23 et 28

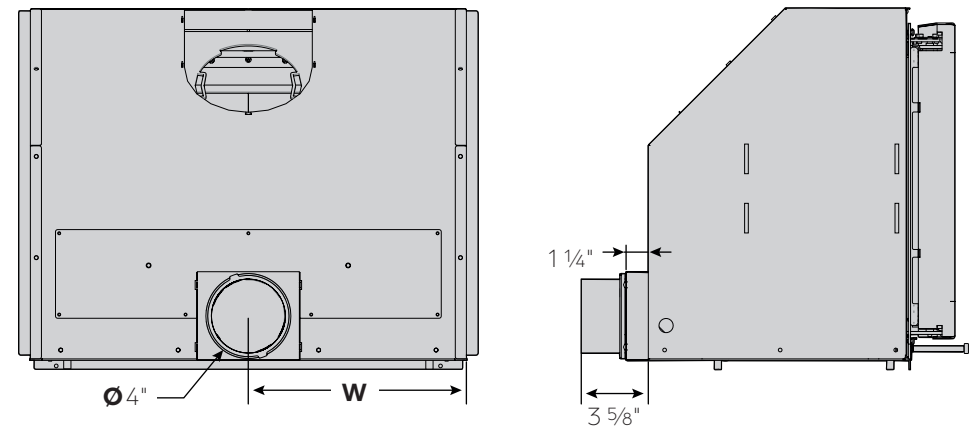

3.3 DIMENSIONS OF THE OPENING



FLUSH THIN EDGE FRAME

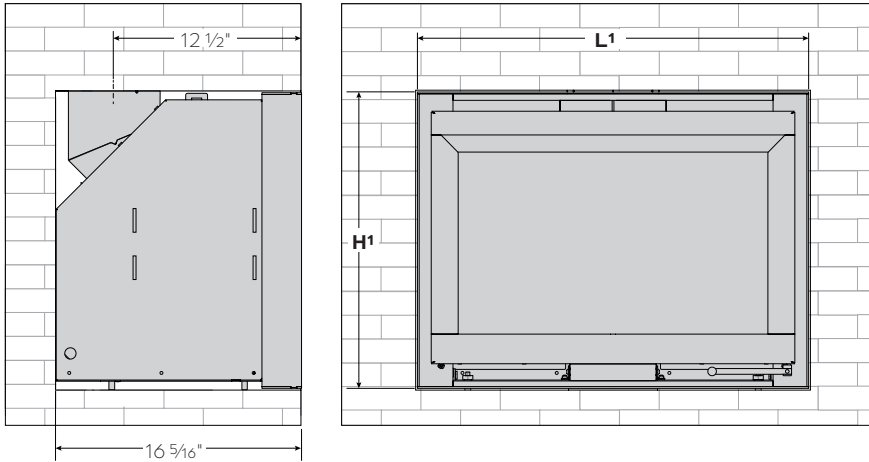

PICTURE TYPE FRAME

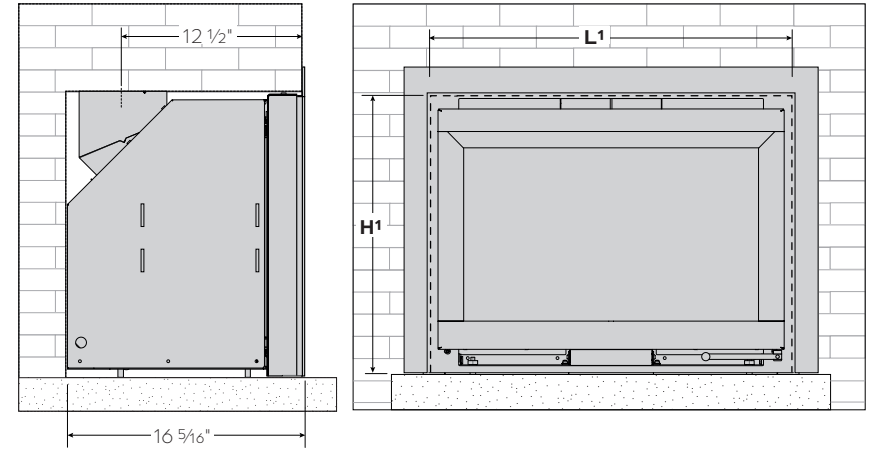

PROTRUDING THIN EDGE FRAME

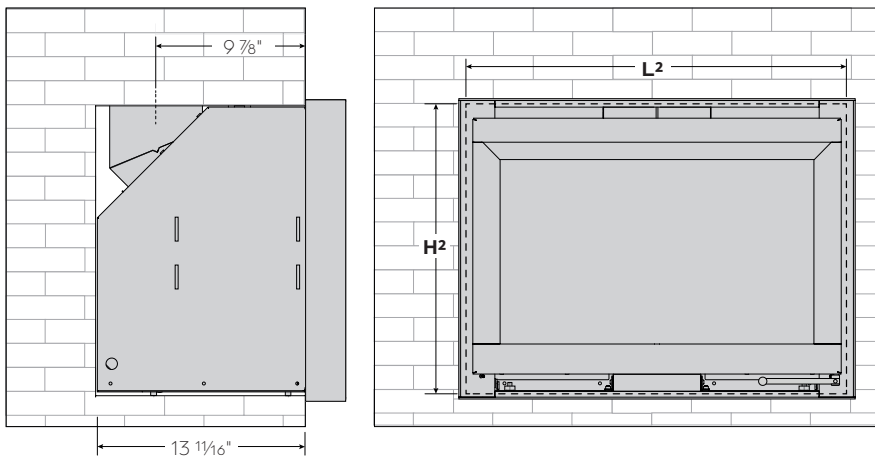

FROM THE GLASS TO THE FRAME

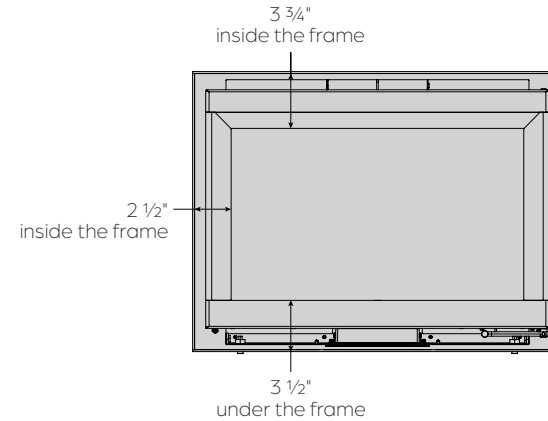

! NOTE

Masonry is not always perfectly level. We suggest that **at least 1/2" clearance** be added to the dimensions listed in the table.

MODEL	L1	H1	L2	H2
66x50	26"	19 11/16"	24 1/2"	18 15/16"
76x55	30"	21 11/16"	28 7/16"	20 7/8"
76x60	30"	23 5/8"	28 7/16"	22 13/16"

! ADVICE

To confirm that the unit can fit in the masonry hearth, order the **installation template** (PW9399700002)

3.4 NON-COMBUSTIBLE MATERIALS



MASONRY HEARTH

The Stûv 6-in is designed to be installed in a masonry hearth. The specific dimensions for each of the frames are indicated on the previous page. For bigger hearths, larger picture type frames are available, or a painted steel plate can be cut in the shape of the hearth.

This fireplace must be installed in a masonry hearth that complies with the building code.

The minimum distance from a perpendicular combustible wall is 14" from the fireplace glass.

COMBUSTIBLE SHELF

It is possible to install a shelf, a television or a decorative object made of combustible material starting **at the height of 16 3/4"** from the inside of the unit's frame and a side trim from a **lateral distance of 1 1/2"**.

To plan their installation, it is important to respect the minimum and maximum dimensions stated below and calculate the dimensions from the inside of the thin or picture-type frame. The increase in the depth of the shelf is calculated at an angle of 45° from the minimum measurements entered. The same goes for the thickness of the side borders.

H = Height under the shelf from the inside of the finishing frame
H_{min.} = **Minimum height : 16 3/4"**

For a specific height:

$$H_{\text{min.}} = P + 8 \frac{3}{4}''$$

D = Lateral distance from inside the finishing frame
D_{min.} = **Minimum distance: 1 1/2"**

For a specific lateral distance:

$$D_{\text{min.}} = E - 2 \frac{1}{2}''$$

P = Depth of the shelf from the face of the finishing frame at the minimum height
P_{max.} = **Maximum depth: 8" from the wall**

For a specific depth:

$$P_{\text{max.}} = H - 8 \frac{3}{4}''$$

E = Maximum thickness at the minimum lateral distance of 1 1/2".
E_{max.} = **Maximum thickness: 4"**

For a specific thickness:

$$E_{\text{max.}} = D + 2 \frac{1}{2}''$$

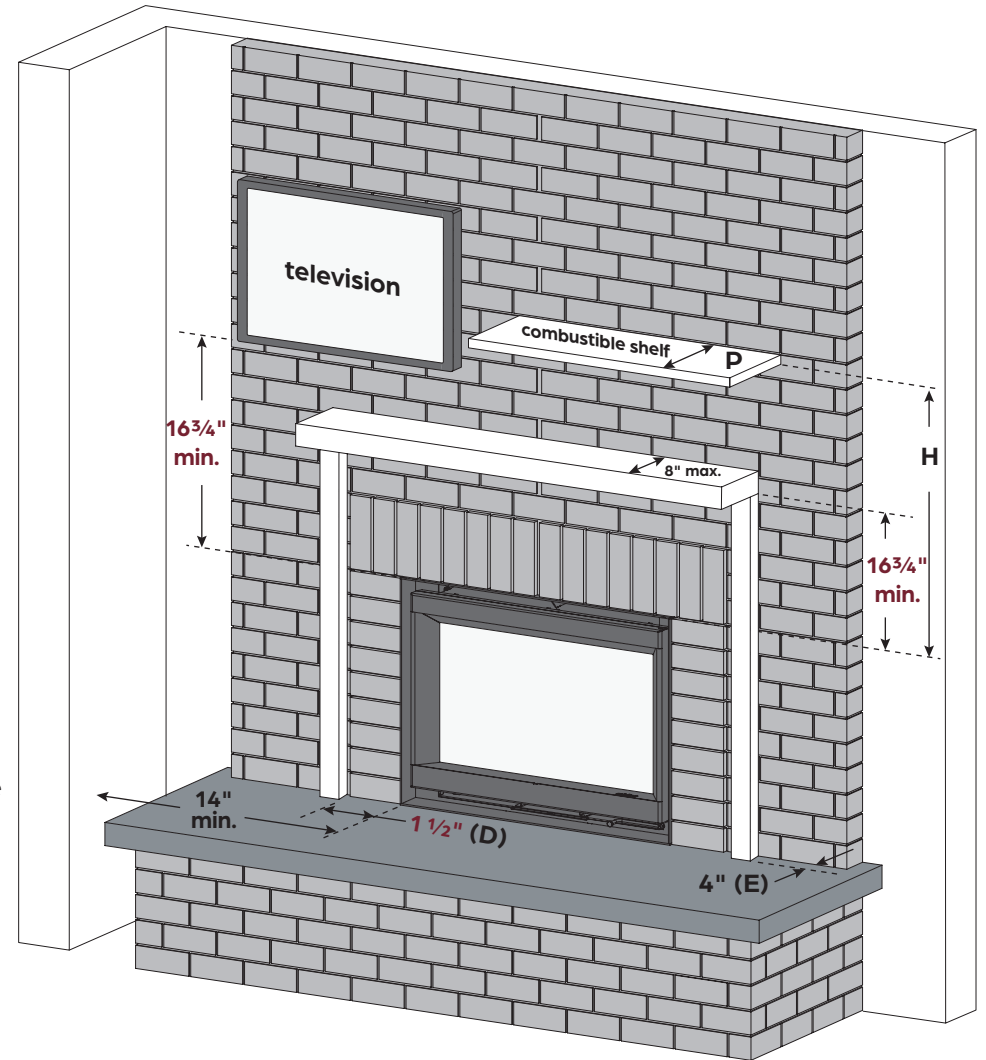

NOTE

Any combustible material cannot be install within the dimensions in red.

3.4 NON-COMBUSTIBLE MATERIALS



EMBER PROTECTION ON THE FLOOR

To be compliant with the building code, an ember protection on the floor is mandatory. The floor area in front of the unit must be protected by a **non-combustible material**.

This protection must extend the entire width of the glass plus 8" on each side, on the projection (**P**) according to the standards applicable in the country concerned. **P (projection) must be calculated starting from the front of the door.**

* The floor protection must be install up to the wall, no matter the distance from the door and a sealing strip must be add to avoid the infiltration of embers into the wall.

Floor protection	J	Z	P (Canada)	P (USA)
66x50	20 9/16"	36 9/16"	16"	14"
76 x 50 & 76x60	24 1/2"	40 1/2"		

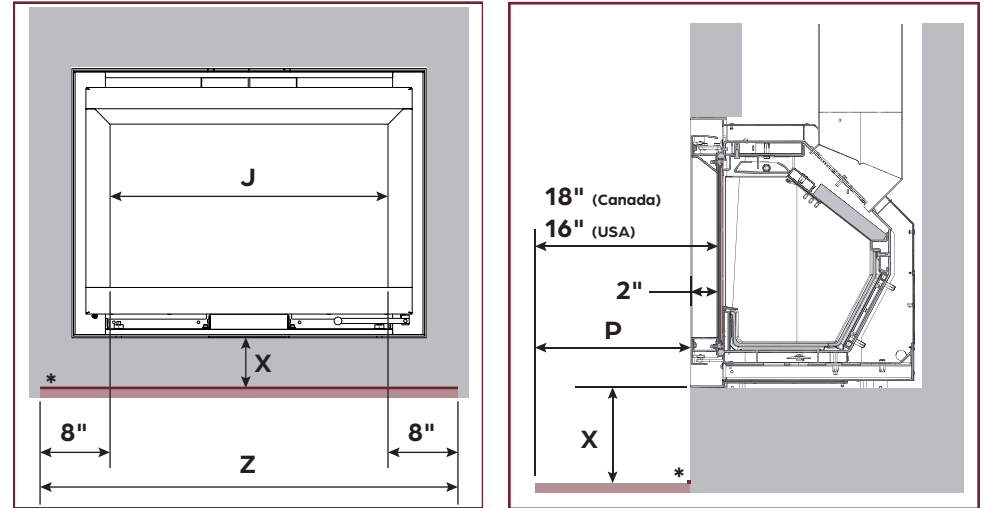

HEARTH EXTENSION

The masonry hearth must conforms to **N.F.P.A. 211**, to **CAN/CSA A405** or to the **National Building Code of Canada**. In any other case, an R-value must be calculated and respected to install the Stûv 6.

In all cases, the chimney and the masonry hearth must complies with the standards listed above.

Follow the minimum distance requirements according to the Country where the fireplace will be installed and affix materials that meet minimum R value requirements. **The X dimension must be calculated from under the frame.**

MODEL	X min. Without R-value	X min. (Canada)	R-VALUE (Canada)	X min. (USA)	R-VALUE (USA)
66x50	8 1/2"	1/2"	1.49	2"	2.96
76x55 & 76x60					

Material

- 1/4" ceramic R = 0.02
- 1/2" cement board R = 0.26
- 1/2" Micore® SB R=1.47
- 1" Micore® SB R= 2.94

Exemple Canada

$$1/2" \text{ Micore® SB (1.47) + } 1/4" \text{ ceramic (0.02) = 1.49}$$

Exemple United States

$$1" \text{ Micore® SB (2.94) + } 1/4" \text{ ceramic (0.02) = 2.96}$$

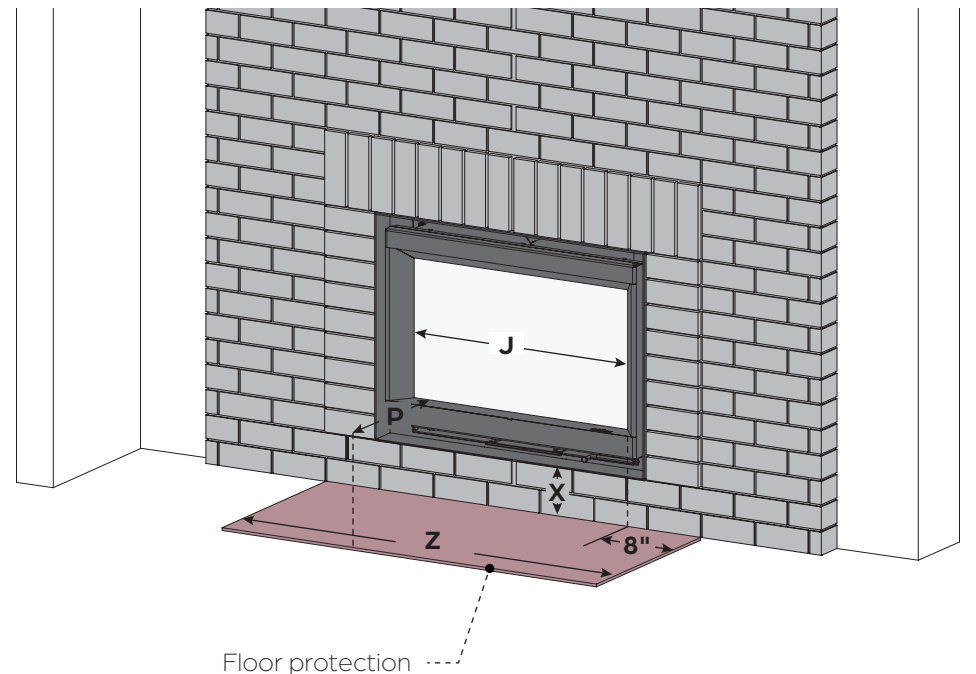

3.5 RISK AREA

The heat radiating from the glass is significant. Any combustible objects must be placed at least 48" by 90° from the glass face to prevent all risk of fire.

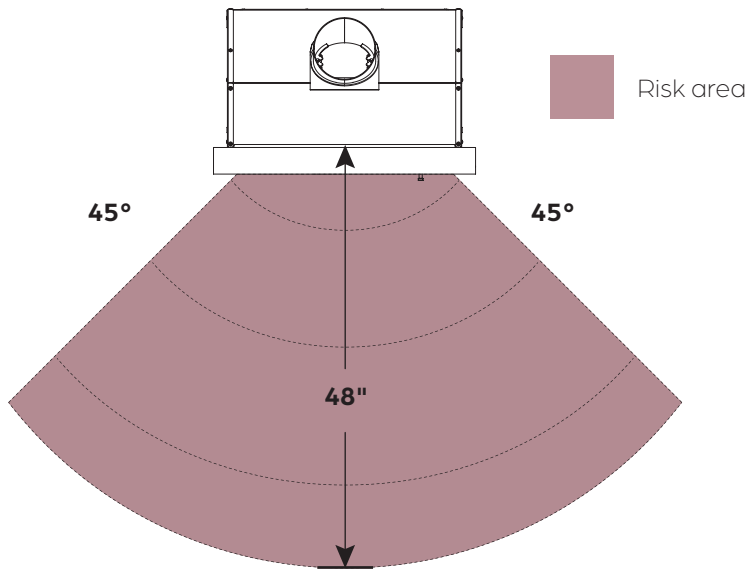
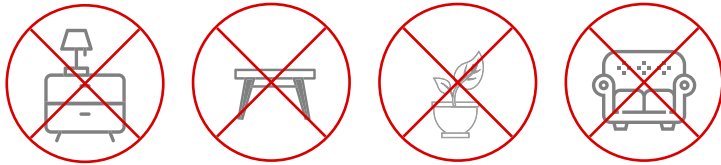

3.6 CONVECTION AIR



The Stûv 6 unit is equipped with an integrated convection air circuit. Fresh air enters into the convection mantel through the inlets under the door and via the bimetallic system, and is heated as it circulates around the combustion chamber.

Natural convection: after being heated in the convection circuit, the air escapes through the hollow joint above the unit's door. A light air flow is naturally created.

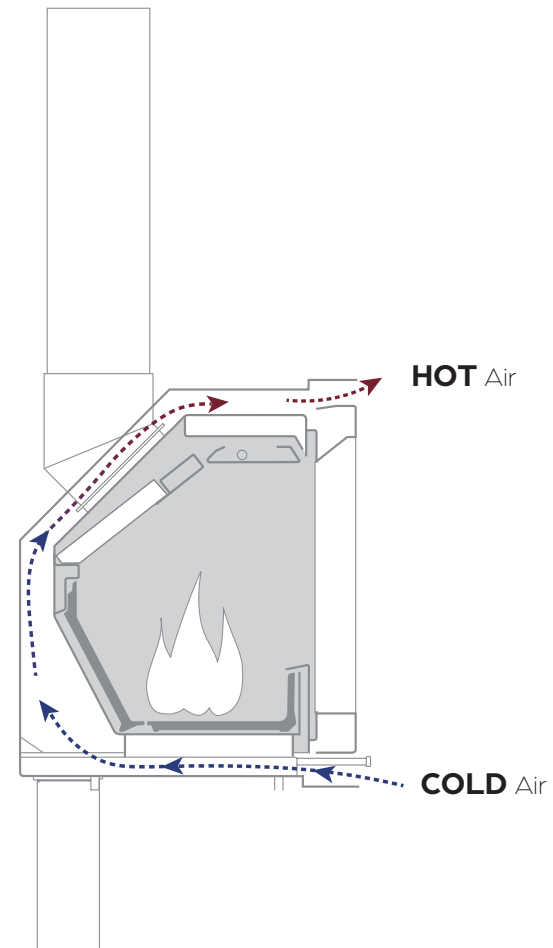

CAUTION - FIRE HAZARD

To avoid major damage, no combustible material should be placed in front of a hot air outlet. In addition, blocking it may cause the unit to overheat and, in some cases, lead to a fire.

Be sure to follow the above recommendations to **avoid heat traps** and other major damage risks.



NOTE

The fireplace needs air for combustion. The Stuv 6 unit is designed to be connected directly to an outside air intake (independent of the house's air). We recommend this placement.

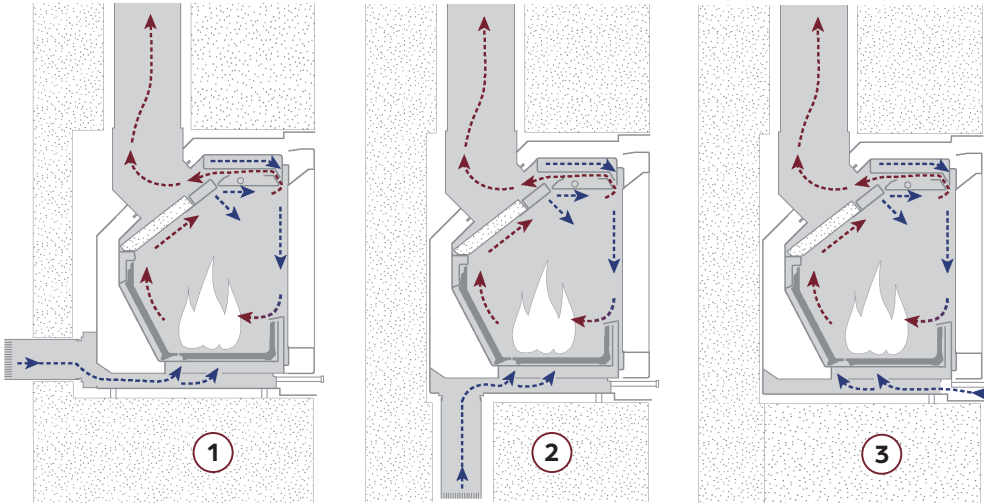

OUTSIDE AIR INTAKE (recommended)

Option 1 Horizontally, behind the fireplace, connected via the outside air intake kit from the back and a Ø4" flexible duct.

Option 2 Vertically, under the fireplace, connected via a flange and a Ø4" flexible duct.

AMBIENT AIR INTAKE

Option 3 If it is not possible to connect the fireplace to the outside air, the combustion air will be taken directly from the room. Make sure that the air exchange in the room is always sufficient when the fireplace is in use.

The duct leading to the outside air...

... must be protected outdoors by a grille whose clear passage section is at least equivalent to the air inlet section.

... must ideally be equipped with an air damper to avoid cooling the room when the fireplace is not in use.

... must be as short as possible to avoid load losses and to keep from cooling the house.



If a standard Ø4" flexible duct is used, we recommend a maximum length of 2 m, with no more than 4 bends. If this is exceeded, it will have to be compensated with a larger diameter and/or a smoother duct.



NOTE

Beware of active air extraction systems (range hood, air conditioning, controlled mechanical ventilation, another fireplace, etc.) in the same space or in an adjacent room. They too consume a large amount of air, which could create negative pressure in the room and hamper the fireplace's operation.

- Watch for the risk of condensation
- Watch for water infiltration and wind impacts, which can damage the system
- Take care not to crush the duct

Check that the chosen configuration is compatible with local and national regulations.

If the fireplace is not directly connected to an outside air intake:

It is possible to install an air intake of at least Ø 2 1/2. It must open near the fireplace, from a ventilated space, a ventilated room (basement) or from outside.

4

INSTALLATION



4.1	COMBUSTION	22
4.2	UNPACKING AND MOVING	23
4.3	DISASSEMBLY	24
4.4	CONNECTION TO THE COMBUSTION AIR INTAKE	26
4.5	REASSEMBLY AND CHIMNEY	28
4.6	ADJUSTING THE DOOR	31

4.1 COMBUSTION



Step 1 If the outside air intake option has been chosen, install the flexible air intake duct for the combustion, connecting either at the back or from underneath.

Step 2 Affix the flange with a clamping collar.

Step 3 Retract the duct to facilitate the support casing's insertion into the wall.

The next steps to follow to connect the outside air kit continue on pages 26 or 27, depending on the option chosen.

! IMPORTANT

Before installing the chimney, check its compliance in the **CHIMNEY section**.

Step 4 Install the flexible or rigid chimney liner (not included) so that it comes out near where the unit will be installed.

Step 5 At the liner's extremity, install the smoke outlet connector (at a 45° or 90° angle) using a claw hose clamp (not included).

Affix the seal included in the complementary box. (See page 25)

Step 6 Retract the duct to facilitate the support casing's insertion into the wall.

Screw the plate inside the masonry hearth with #10 or $\varnothing 3/16$ " screws.

1

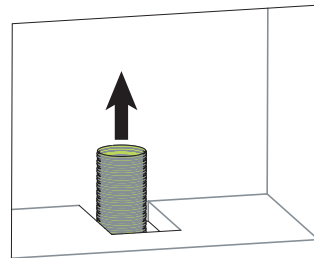

2

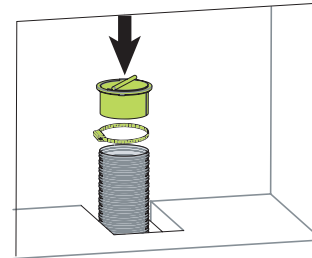

3

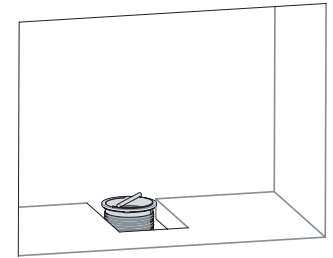

4

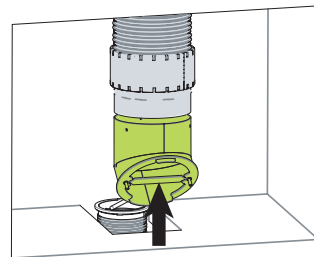

5

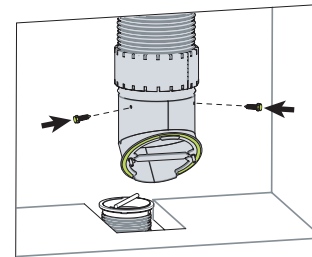

6

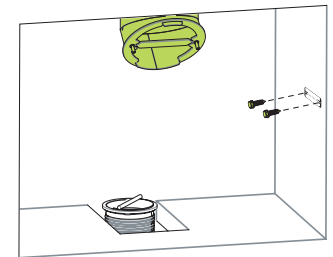

Ce foyer peut avoir été modifié pour accueillir un encastable. Il doit être inspecté par une personne qualifiée avant d'être réutilisé comme foyer conventionnel.

This fireplace has been altered to accommodate a fireplace insert and should be inspected by a qualified person prior to re-use as a conventional fireplace.



IMPORTANT

The paint is not cured. It is therefore fairly **fragile**, but it will harden after being heated several times. Handle the unit with care.

Step 7 Use a pallet truck to move the fireplace close to its final location. Carefully remove the packaging.

Step 8 Remove the four retention screws securing the fireplace to the pallet.

Step 9 Fold the mounting brackets under the fireplace.

Step 10 To facilitate handling, insert the Stûv handles in the slots provided for this purpose on the sides of the fireplace.

They can be used in either direction.

7

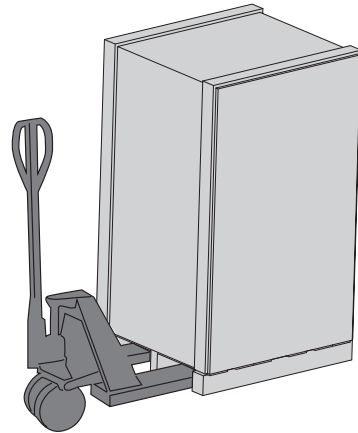

8

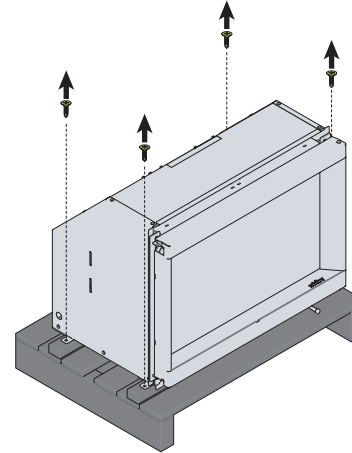

9

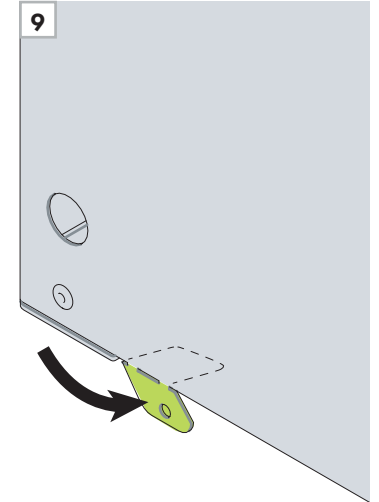

10

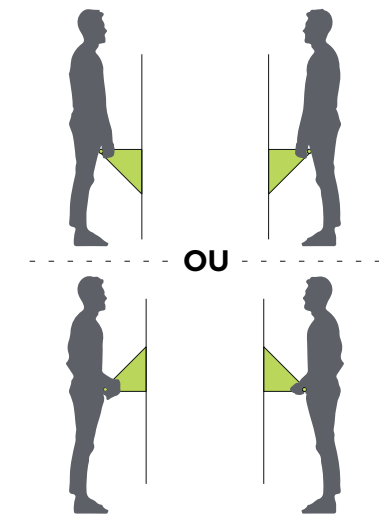
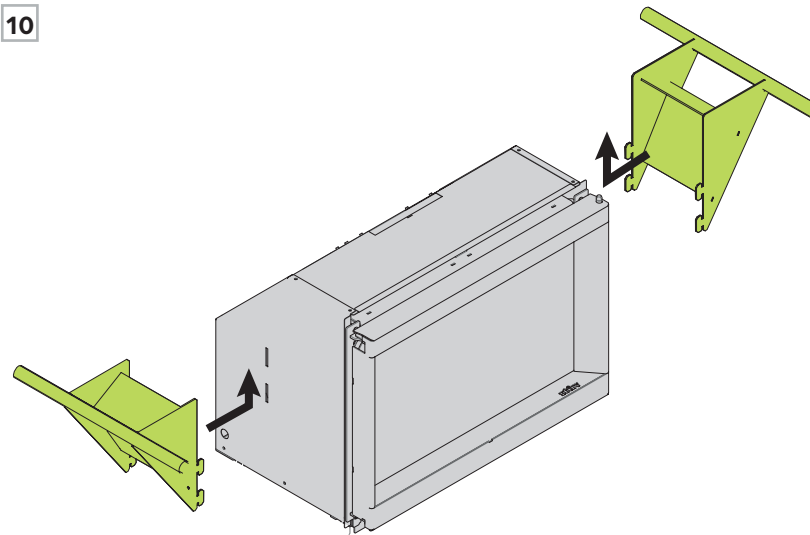



Step 11 Open the door, using the small handle on the bottom right.

Step 12 Remove the door by freeing the hinges from their support.

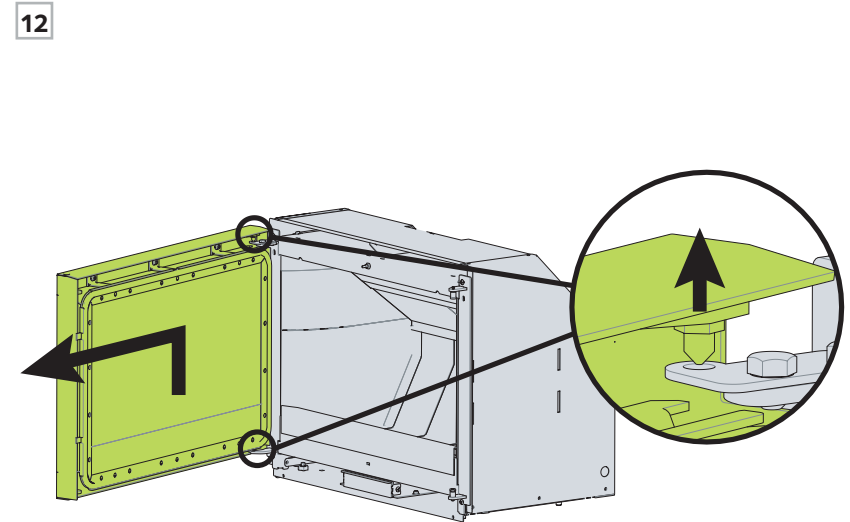
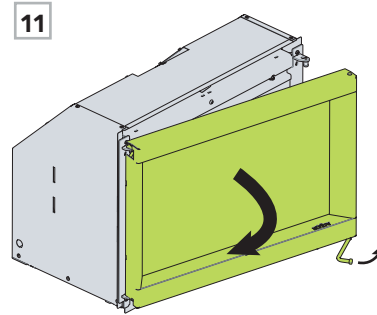

Step 13 Remove the complementary box from the combustion chamber and check its contents:

1. **1x** can of spray paint for touch-ups
2. **1x** black Stûv glove (to be given to the end user)
3. **1x** installation manual
4. **2x** nuts and **1x** seal for the smoke outlet connector
5. **4x** leveling feet
6. **4x** set screw
7. **2x** pairs of white gloves for handling the fireplace
8. **1x** plate to screw in the fireplace

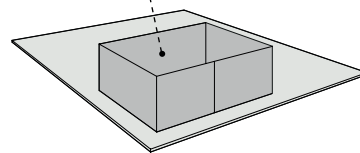

Step 14 Push the two vermiculites from the side and remove the middle one.

Step 15 Remove the left and right vermiculites.

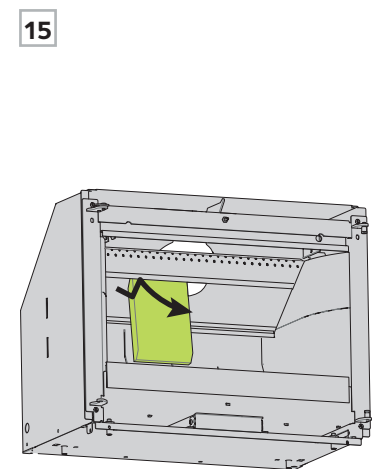
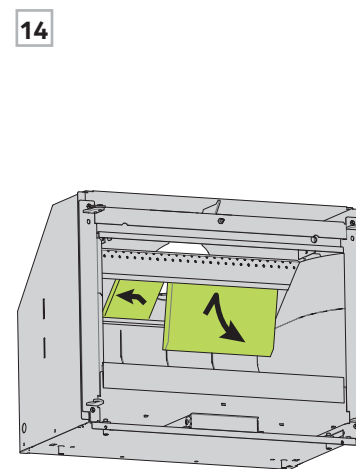

4.3 DISASSEMBLY



Step 16 Push the bottom of the cast iron part at the back of the fireplace to lift it up.

Step 17 Do the same for the two middle rows.

Step 18 To remove the cast iron parts on the bottom, slide slightly backward. Remove the two in the middle.

16

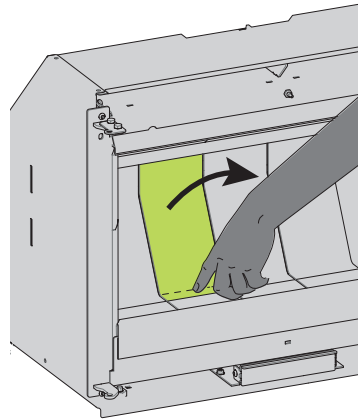

17

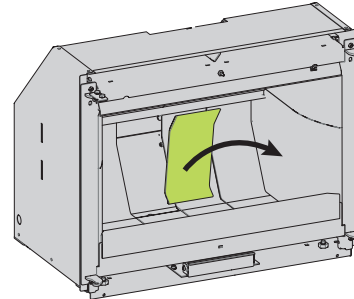

18

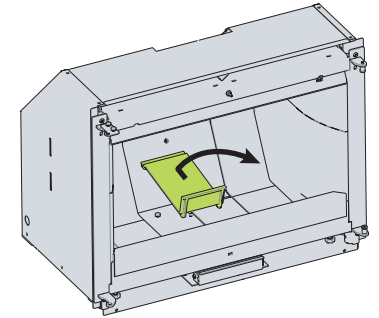

Step 19 Remove the Torx 30 screws at the back of the fireplace to separate the fireplace from the casing.

Step 20 Pull on the upper part of the combustion chamber to tilt it forward, then lift in order to free it from the casing.

Step 21 Tug lightly, using the casters to slide the combustion chamber out of the casing. Place the chamber on a protective fabric or in a safe spot.

19

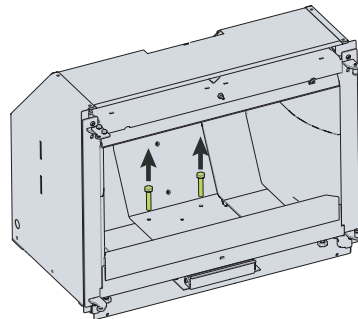

20

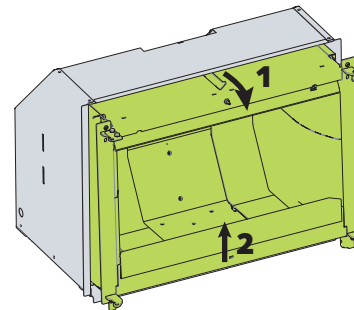

21

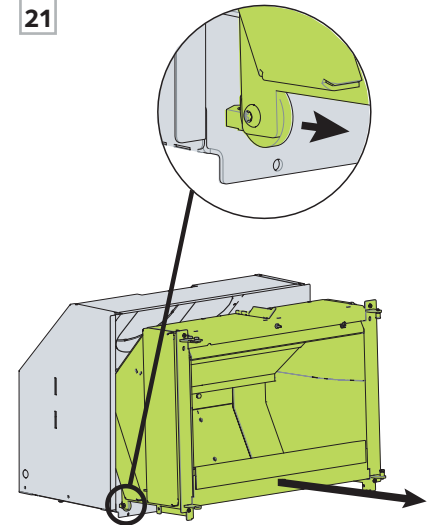

4.4 CONNECTION TO THE COMBUSTION AIR INTAKE



CONNECTION - UNDERNEATH

Step 22 Using a hammer, knock out the perforated circle under the casing.

Step 23 Position the fireplace in the recess.

Step 24 Remove the two screws securing the plate at the back of the casing.

22

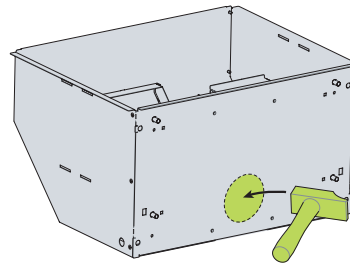

23

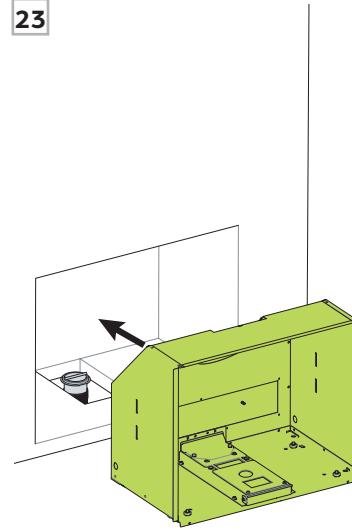

24

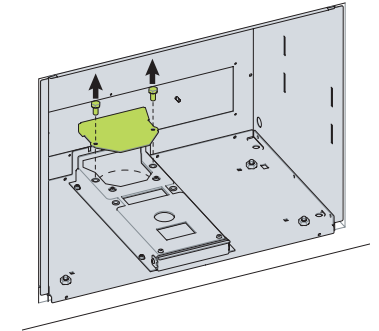

Step 25 Connect the outside air intake duct by turning it counterclockwise.

Step 26 Screw the plate back on, making sure the seal is still securely in place.

25

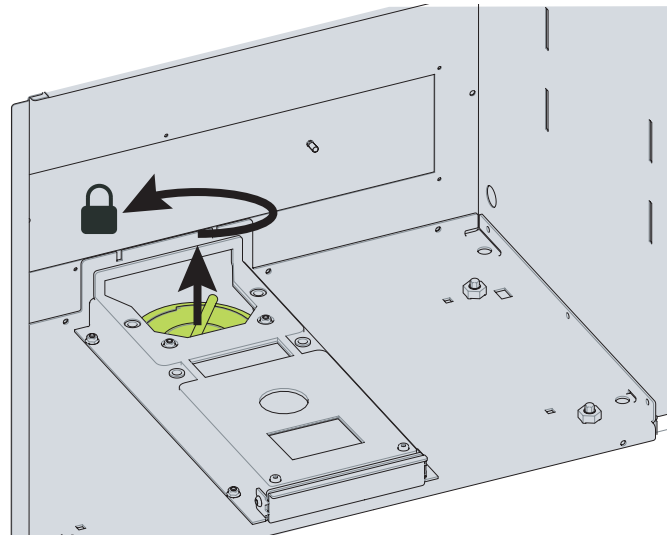

26

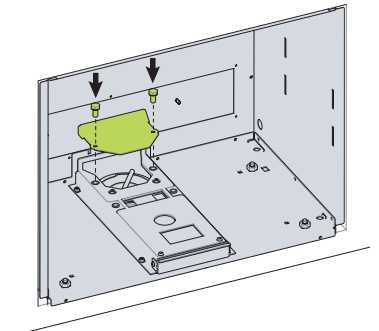



CONNECTION - FROM BACK

Step 27 Using a hammer, knock out the perforated rectangle at the back of the casing.

Step 28 Still at the back of the casing, position and screw on the connector.

Step 29 Attach the flange to the connector with three screws, inserting a gasket seal between the two.

Step 30 Connect the outside air intake duct to the flange using a clamping collar.

Step 31 Position the fireplace in its final location by sliding the duct into the recess created.

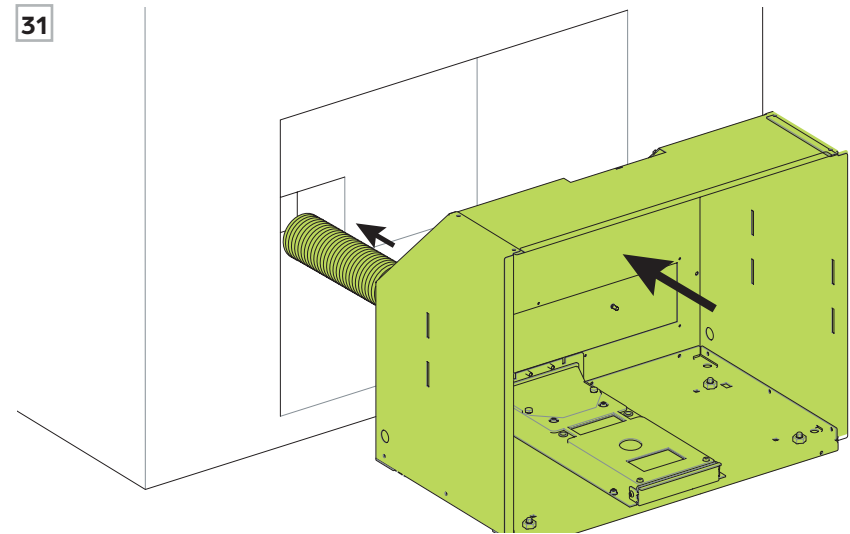
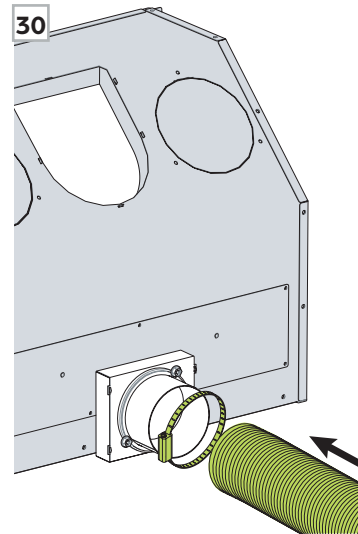
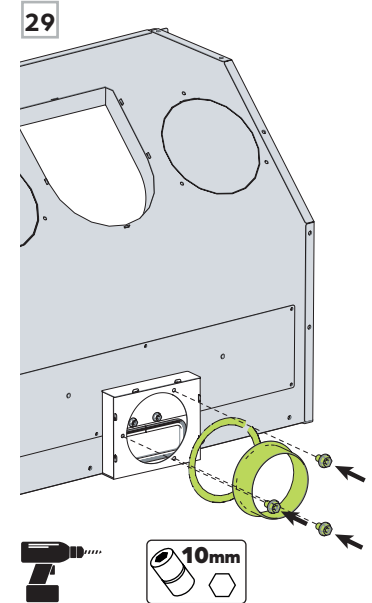
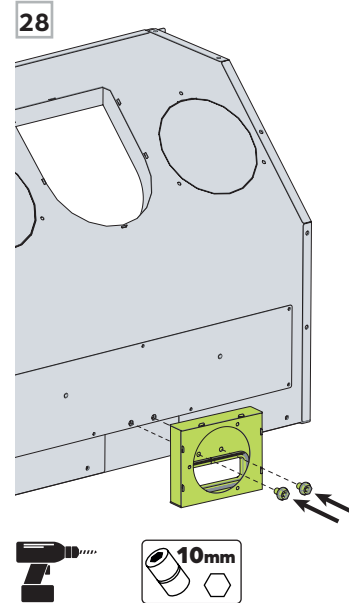
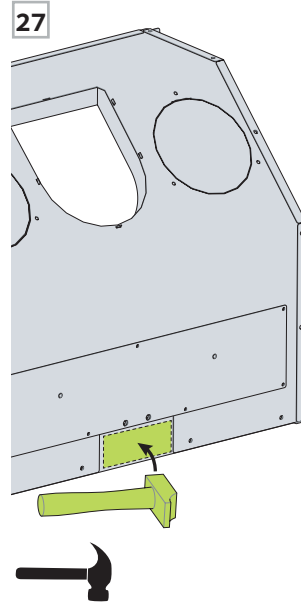



WITH CONNECTION

Installing the front plate

Step 32 The plate can be found in the box containing the outside air kit. Position it in the middle under the combustion chamber.

Step 33 Affix the plate on both sides with screws.



FOR ALL INSTALLATION

Follow these next steps.

Step 34 For the picture type frame and the thin edge frame, the distance between the front of the support casing and the front of the hearth must be **2 1/2"**.

* **Validate the distance in the manual provided with the frame.**

Step 35 Determine which feet are required between the set screws or the leveling feet and install them under the casing.

Step 36 After placing the casing in its final location, level it with the four feet. **If the adjustment range is not enough for this installation, use the longer leveling feet provided in the complementary box.**

Step 37 After leveling the casing, use a grinder to cut the part of the feet that exceed the nut. The feet cannot be adjusted after the cut.

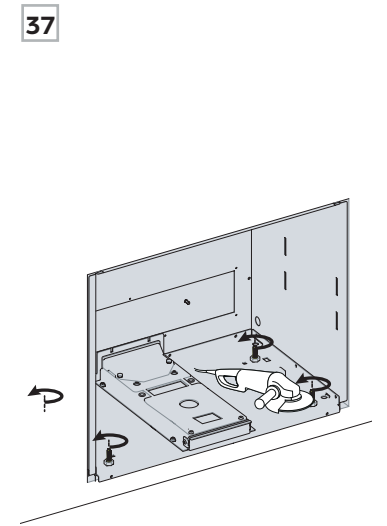
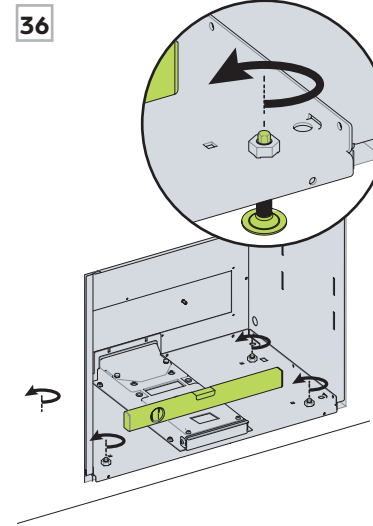
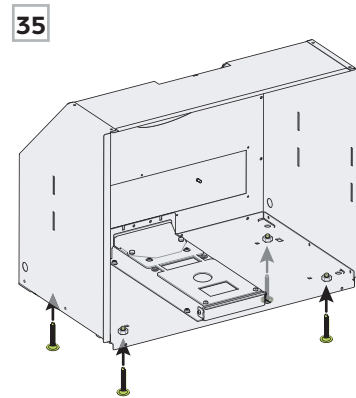
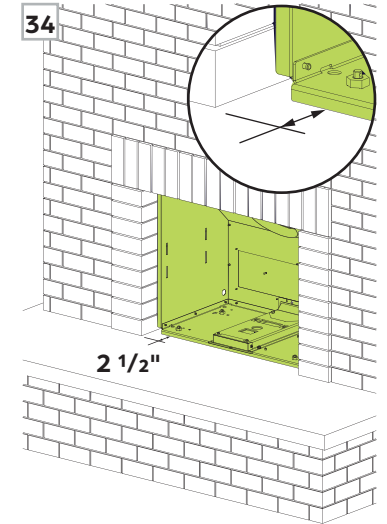
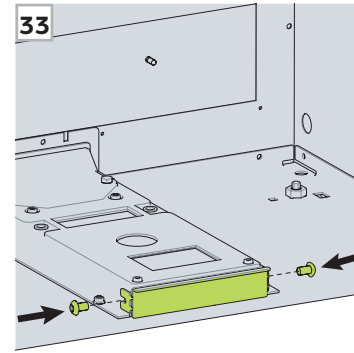
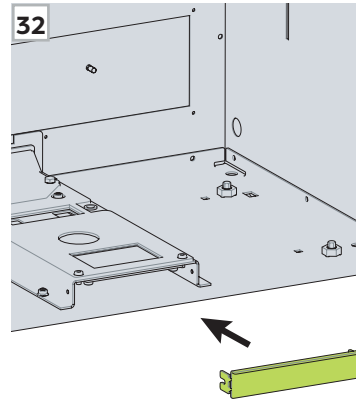



Step 38 attach the casing to the recess with self-drilling wood screws (not included).

Step 39 Using the casters, slide the combustion chamber all the way back into the casing.

Step 40 Using the two screws previously removed, secure the combustion chamber to the casing.

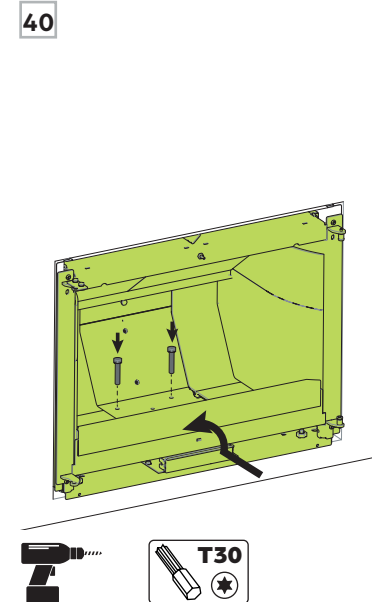
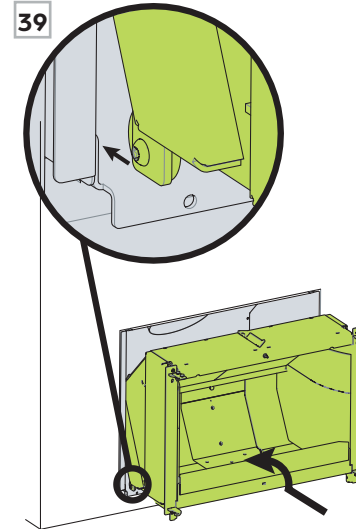
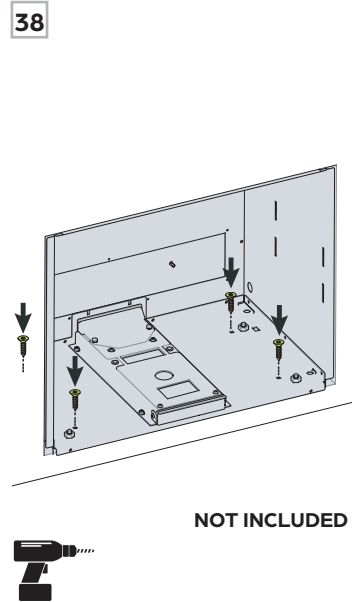

Step 41 Put the cast iron parts from the bottom of the chamber back into place.

Step 42 Put the back parts back into place.

Step 43 Use the handle to securely connect the smoke outlet connector.

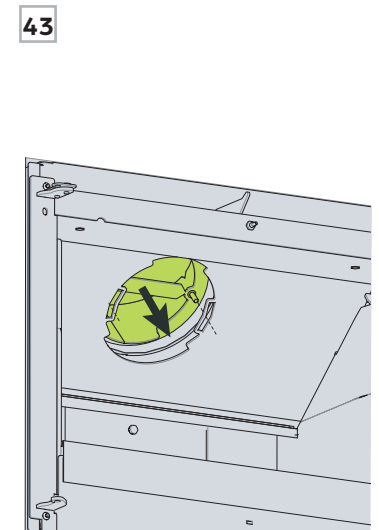
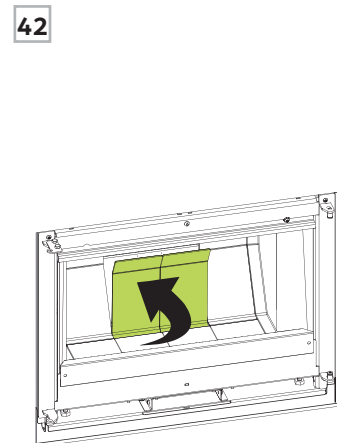
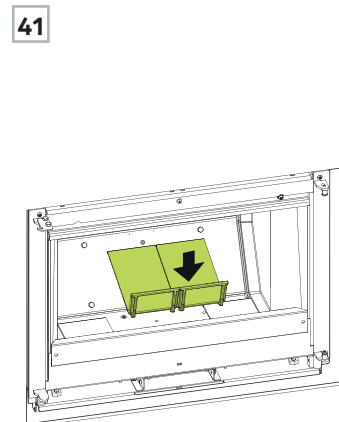



Step 44 Insert the rods in the circular grooves on the fireplace's smoke outlet and position the handle horizontally. Secure the fireplace and the smoke outlet with nuts.

Step 45 Using a pair of pliers, pivot the handle. Repeat the torsion until the small corners have broken off. Throw away or put in the recycling bin.

Step 46 Put the vermiculites back in place, starting with those on the sides.

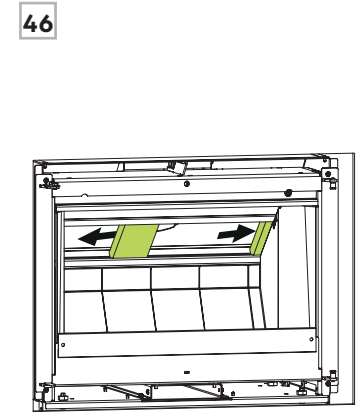
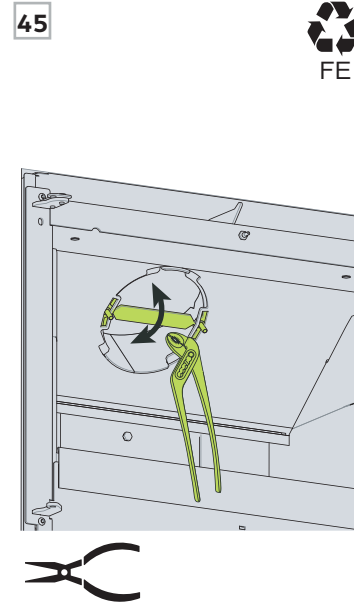
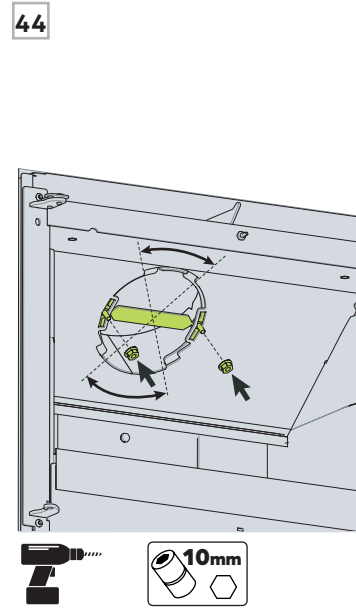

Step 47 Place the middle vermiculite back in place and rebalance everything.

Step 48 Follow the installation instructions for the finishing frames (thin edge or picture type frame).



Step 49 Put the door back on its hinges.

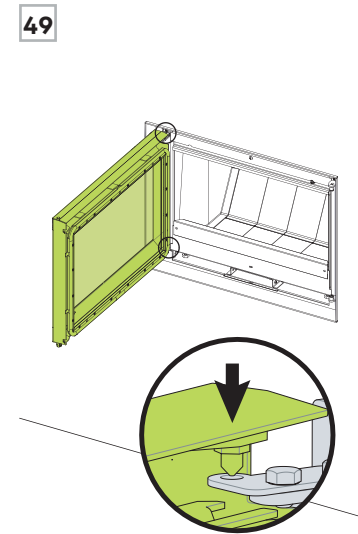
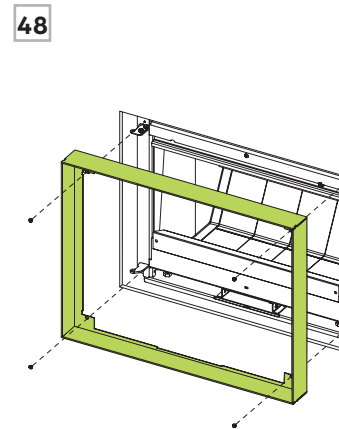
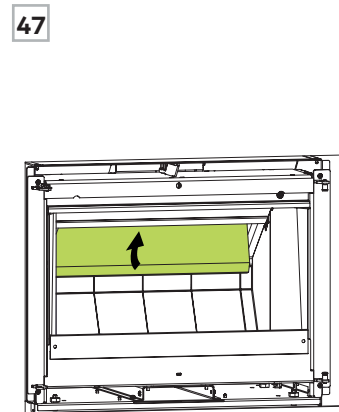

4.6 ADJUSTING THE DOOR



If the door is not leveled or if the grip is not airtight, it can be adjusted at the top of the rotation axis.

Step 50 Slightly loosen the 2 bolts with a 10mm wrench.

A If the side opposite the rotation axis is too low or if the grip is too tight, push the front of the rectangle to the left.

B If the side opposite the rotation axis is too high or if the grip is too loose, push the front of the rectangle to the right.

NOTE

It is recommended to adjust the door to position the hooks in the center of the copper cylinder.

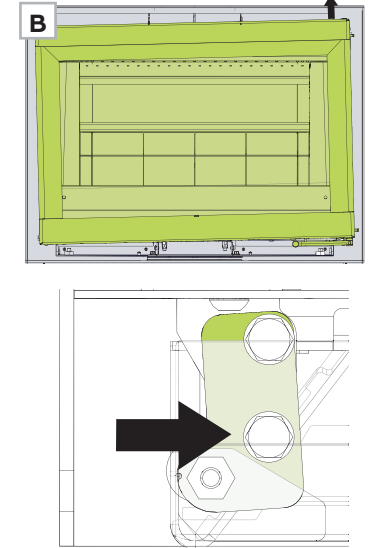
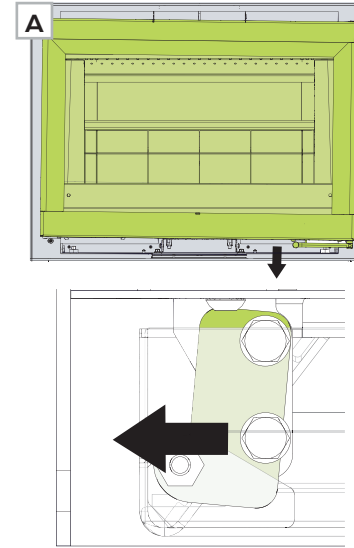
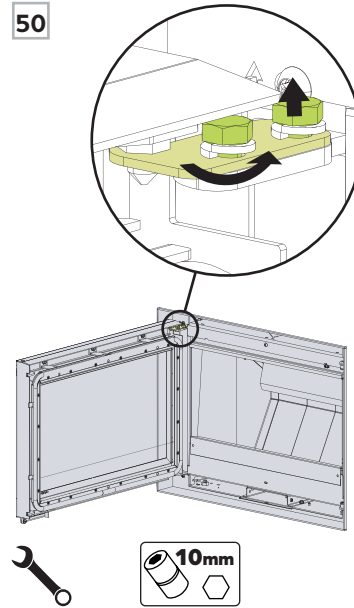

Step 51 Gradually adjust the door according to the instructions above. It may take several tries to get it perfectly level. Open and close it a few times to check the ease to open the door.

Step 52 When the door is level, tighten the bolts.

Step 53 Also check the door's airtightness, by placing a sheet of paper in the door and closing it. Try to pull the paper out all along the door frame. If the door is airtight, you will not be able to remove the paper.

If the paper moves or the door's grip is not perfect, redo the adjustment steps

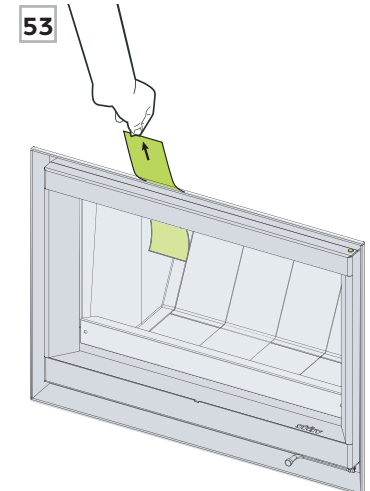
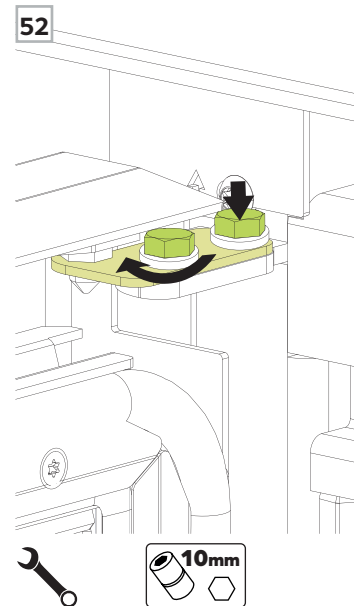
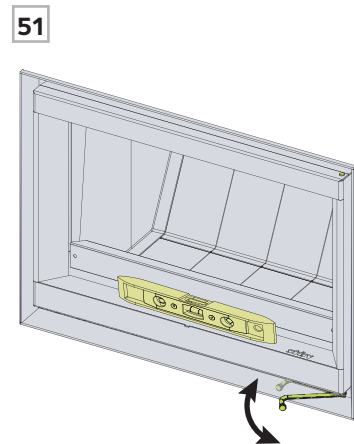

5

CHIMNEY

5.1	DIMENSIONS AND CERTIFICATION	33
5.2	TYPICAL INSTALLATION	33
5.3	CONNECTION TO A CHIMNEY PIPE	34



5.1 DIMENSIONS AND CERTIFICATION

5.2 TYPICAL INSTALLATION



NOTE

- Do not use makeshift means during installation. This could pose a danger and cause a fire.
- Do not connect the appliance to a chimney that is already connected and used by another appliance. A chimney used as an outlet for a fireplace must not be used for more than one appliance.
- Do not cut trusses, rafters or ceiling joints without consulting a building official. Do not remove bricks, stones or mortar from the existing fireplace. These actions might compromise the structural integrity of the masonry hearth.
- Wood-burning fireplaces must be installed with a continuous rigid or flexible liner (6 or 7 inches in diameter) from the fireplace to above the chimney. The liner must be in compliance with the Standard for Lining Systems for Existing Masonry or Factory-Built Chimneys and Vents, or CAN/ULC-S640, the Standard for Lining Systems for New Masonry Chimneys, or UL-1777, according to the installation standards in effect at the installation's location.
- A chimney used to evacuate smoke from an insert must not be used for any other appliance.
- Refer to the chimney manufacturer's instruction manual for instructions on how to install the chimney.
- If this unit is not installed properly, a fire may result. To reduce the risk of fire, follow the installation instructions.
- Contact the local authorities to obtain a building permit and take note of all applicable regulatory requirements.

CHIMNEY DIAMETER



A 6" UL-1777, ULC-S635, ULC-S640-compliant liner must be used to connect the smoke outlet.

A 7" option is also available.

Follow the instructions below to install the chimney. Always refer to the chimney instruction manual.

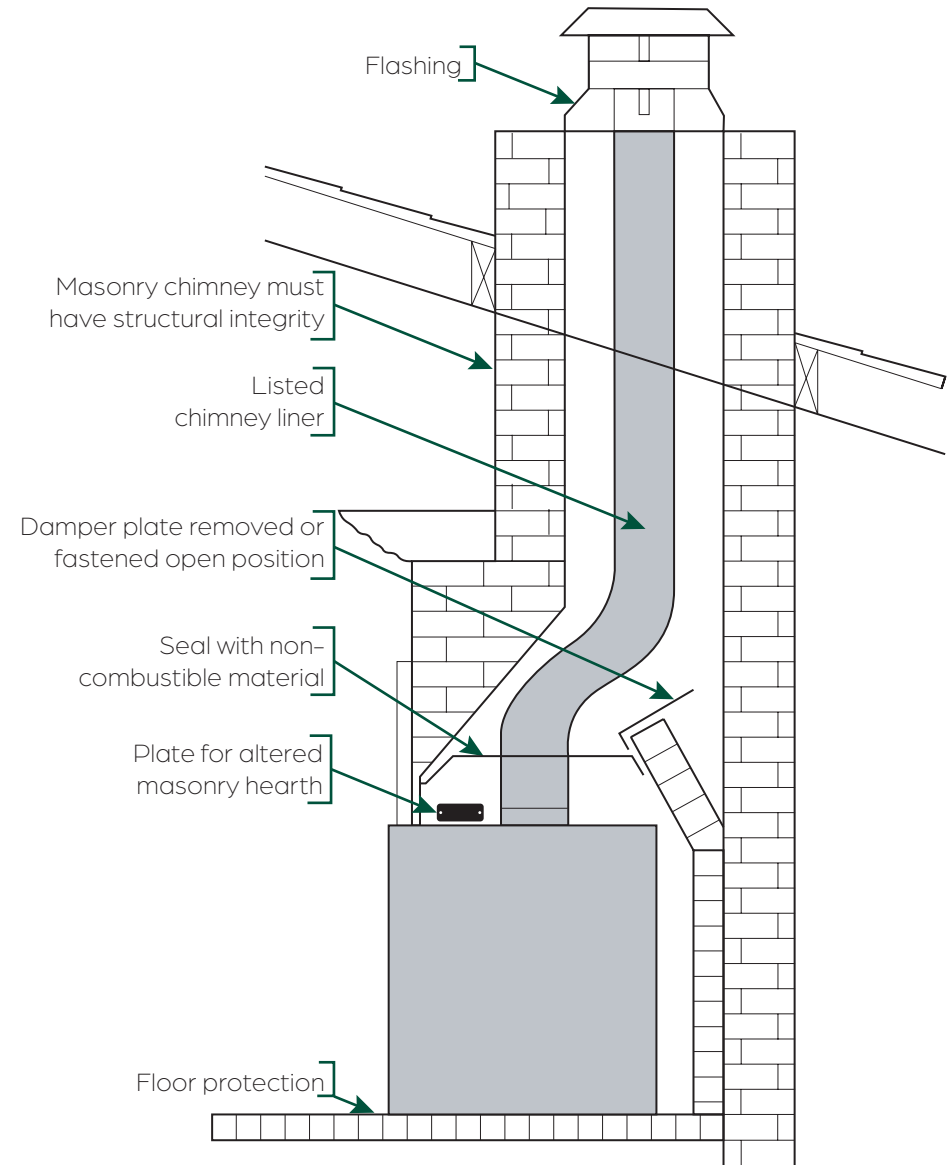

5.3 CONNECTION TO A CHIMNEY PIPE



FLEXIBLE LINER

When ordering the unit, a decision must be made regarding the smoke outlet connector to the chimney's configuration.

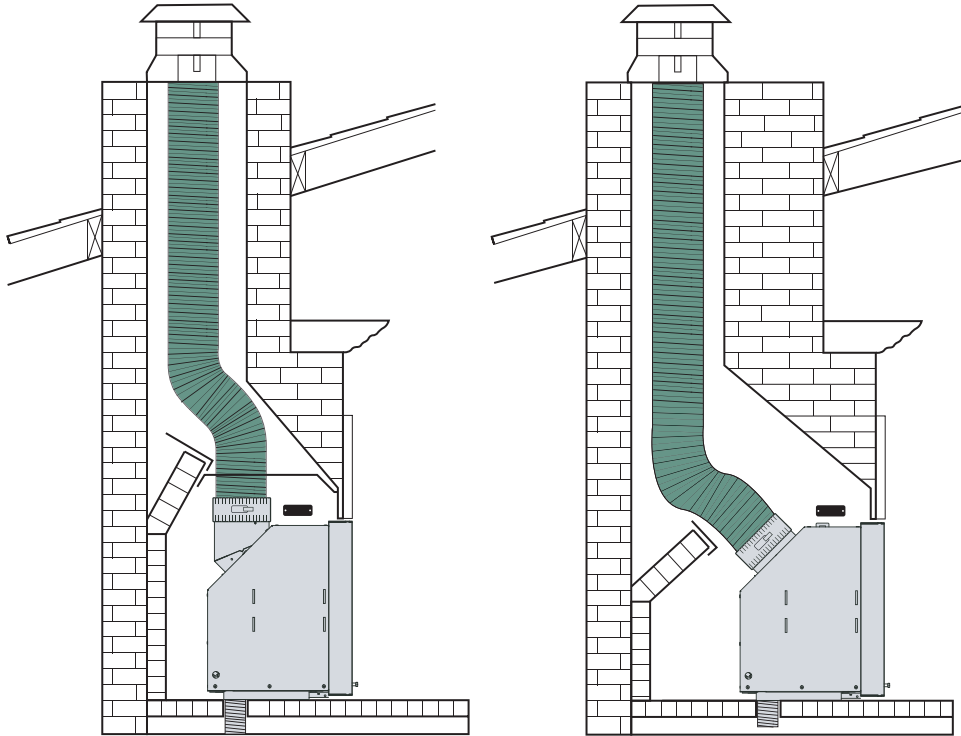

RIGID LINER

Fix the rigid liner directly to the smoke outlet connector.

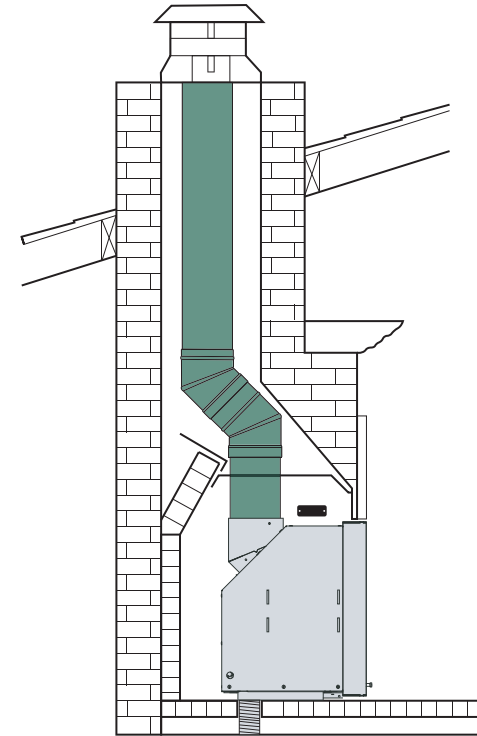

WATERTIGHTNESS

The different elements that make up the connection between the fireplace and the smoke outlet pipe, as well as those that make up the chimney pipe itself, must be placed in such a way that they are watertight (condensate) rather than airtight (smoke).

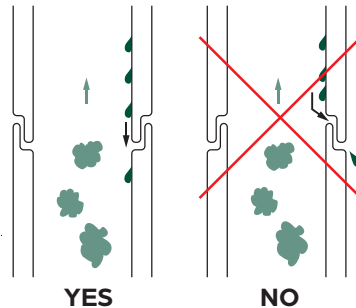

HEIGHT

MINIMUM 15' / MAXIMUM 45'

It is strongly recommended to install a chimney with an height between **15 feet minimum and 45 feet maximum** from the bottom of the appliance to below the rain cap.



6

USE

6.1	WOOD SELECTION	36
6.2	SAFETY	37
6.3	DOOR HANDLING	38
6.4	STARTING THE FIRE	38
6.5	RELOADING THE FIRE	40
6.6	ASH REMOVAL	40

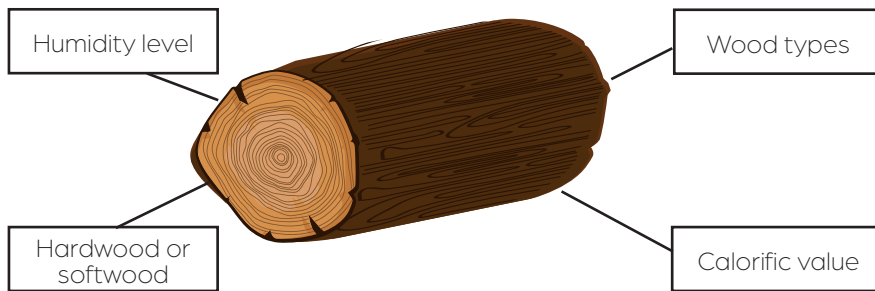

HUMIDITY LEVEL

It is essential to use **dry wood** that has a moisture content of **less than 18%**. This will ensure **more efficient** and **clean combustion**.

Using **wet or semi-dry wood** with a moisture content **higher than 18%** will result in mediocre and less efficient combustion. The fire will be smaller and difficult to start. It will release a great deal of **black smoke** and **pollution** into the air and also sully your glass and chimney pipe.

To choose dry wood, use a moisture meter or check if...

- The wood is lightweight and slightly split
- You hear a snap when banging one log against the other
- The bark comes off easily
- There are cracks from the centre to the edge

HARDWOOD OR SOFTWOOD

The harder a wood is, the more heat it will produce and the slower it will burn (at equivalent moisture content).

Softwood can be used as kindling over hardwood. It burns more quickly (at equivalent moisture content) despite its lower calorific value.

- **Hardwood:** oak, beech, elm, ash, acacia, hornbeam, maple
- **Fruit tree wood:** walnut, cherry, pear, apple, olive
- **Softwood:** poplar, birch, linden, locust, chestnut
- **Resinous wood:** maritime pine, spruce, Scots pine, fir, larch

WOOD TYPES

Ash and beech are recommended as firewood as they dry quickly and are easy to find. They must be stored under a shelter immediately after being cut and split, otherwise they rot very quickly and lose their calorific value. They are easy to light and produce very bright, lively flames.

Maple has a good calorific value. It produces fires and embers that last a long time.

Oak is an excellent fuel, but unlike other wood species, it has to remain uncovered for two years to allow the rain to remove the tannins it contains. Then it has to be stored under shelter for another year or two before it can be burned. Small oak branches have a high sapwood content, which burns too quickly. Oak burns slowly, produces a calm fire and beautiful embers. It is ideal for barbecuing and for moderate fires.

Hornbeam, cherry and fruit trees are excellent fuels, but are rare. These are hardwoods. They produce beautiful, harmonious and calm flames, and beautiful embers. Ideal for a barbecue or a calm fire.

Birch, linden, chestnut, poplar and black locust are broad-leaved trees with soft wood. They produce beautiful, harmonious, but bright flames and few embers. Because they burn quickly, they can be used to start (or restart) the fire. Caution: Poplar produces abundant and volatile ash while black locust produces significant sparks.

Resinous woods generate a lot of heat, but they burn quickly. They throw sparks and the resins they contain cause build-up in the chimney.

CALORIFIC VALUE

Each type of wood has a different calorific value and all burn in different ways.

We strongly encourage the use of hardwoods such as hornbeam, maple, oak, ash, elm and beech. They produce beautiful flames and plenty of embers that glow for a long time.

**! CAUTION – NOT TO BE USED****Burn only firewood. Do not burn:**

- Garbage
- Lawn clippings, yard waste or unseasoned wood
- Materials containing plastic, petroleum-based products, gasoline, liquid fuel or rubber, including tires
- Waste petroleum products, paints or paint thinners, or asphalt products
- Industrial solvents
- Flammable liquids such as naphtha and motor oil
- Painted wood, varnished wood or chemically treated wood
- Materials containing asbestos
- Construction or demolition debris
- Salt water driftwood or other previously salt-water saturated materials
- Railroad ties or pressure-treated wood
- Manure or animal remains
- Paper products, cardboard, plywood, or particleboard. The prohibition against burning these materials does not prohibit the use of fire starters made from paper, cardboard, saw dust, wax and similar substances for the purpose of starting a fire in this unit
- Any substance that emits dense fumes and strong odours

The heat produced by these materials is too great and can damage the appliance, in addition to causing soot to form on the glass and on the inside of the chimney pipe. These materials produce toxic and polluting fumes, such as carbon monoxide, which can be hazardous to health. Burning these materials may result in release of toxic fumes or render the heater ineffective and cause smoke.

Composite logs (ecological): Composite/ecological logs are to be avoided. They sometimes emit residues that sully the mechanisms and cause the appliance to age poorly.

Stûv appliances are designed for domestic use and must never be used to incinerate garbage of any kind.

This wood heater has not been tested with decorative sets (logs, pebbles) for unvented gas fireplaces. To reduce the risk of fire and/or injury, it is prohibited to install a decorative set in the combustion chamber of the appliance.

! CAUTION
Read the safety instructions on page 7 before using the insert.
 Upon first use, some smoke or odours may be produced. **Ventilate the room well.**

! In case of a chimney fire

1. Call the fire department.
2. Put out the fire with a type A or ABC extinguisher (powder, foam or water and additive). Avoid using a bucket of water or any other hazardous method to put it out.
3. Air out the room in which the unit is located.
4. After a chimney fire, have the chimney cleaned and inspected by a professional.
5. Make any repairs necessary before using the unit again.

If the outside temperature is higher than the inside temperature, load more paper and more kindling to properly heat the chimney pipe and thus counter the temperature imbalance. First ignite balled-up pieces of paper and about 1 to 1 1/2 lb. of kindling $\pm 3/4$ sq. in.-thick.

The maximum load to avoid overfiring is **2x the weight of the hourly consumption**. Refer to the table on page 5.

! IMPORTANT

Store the wood in a weatherproof location to keep it dry. Do not store it in the risk area, insert loading area, ash removal area or inside the mandatory clearances indicated in the **DIMENSIONS** section.



Step 1 To open the fireplace, pull on the handle under the door and swing open.

Step 2 To close the door, swing shut and then press on the end of the handle as hard as you can with your thumb.



CAUTION

The door may be hot!

Be careful with the door.

Do not strike or slam the door. It may broke the glass.

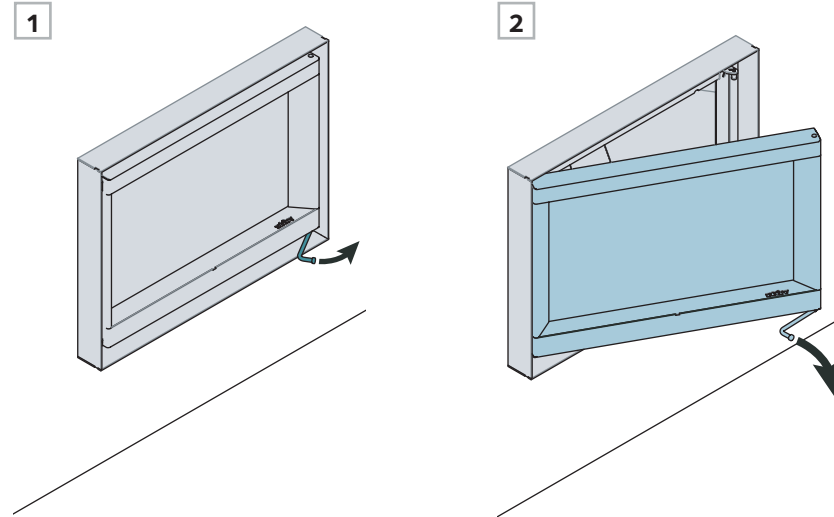

6.4 STARTING THE FIRE

This Stûv unit needs air for combustion. Ideally, the installer will connect the fireplace to the outside air using a duct.

If the air damper is installed, open it to start the fire.

Do not build the fire too close to the glass and do not start a fire if the glass is broken.

Always keep the duct free of obstructions.

The fireplace's proper operation can be affected by air-supplied systems installed in the same room (air exchanger, range hood, air conditioning, etc.) and this may result in smoke backflow.



UPSIDE-DOWN FIRE!

We recommend starting the fire using the upside-down fire method. It is more efficient and eco-friendly.

The advantages:

- Putting the logs in first will greatly reduce the smoke that is produced since the temperature will rise gradually.
- The fireplace's efficiency will also increase with complete combustion.

- Once the logs underneath have caught fire, the combustion gases pass through the flames. As they increase in temperature, they are nearly completely degraded and the fireplace therefore emits less CO and fewer particles.
- With this method, there is less risk of logs falling during combustion since the bigger pieces are at the bottom.

The instructions for building a upside-down fire can be found on the next page.



! MAKING AN UPSIDE-DOWN FIRE

Step 1 Place the big logs in the combustion chamber first.

Step 2 Add smaller pieces with no bark, placed perpendicularly.

Step 3 Gather the kindling and cover the wood already present (approximately 1 kg of kindling).

! NOTE
The total load must not exceed $\frac{2}{3}$ of the combustion chamber so as not to overheat the unit.

Step 4 Insert an eco-friendly firelighter in the kindling.

! CAUTION
It is recommended to use fire starters made from sawdust or wood fiber, without chemical and toxic additives. Paraffin or other waxy substances can block the air supply system.

Step 5 Light the fire directly on the firelighter.

Step 6 Leave the door ajar for 20 minutes.

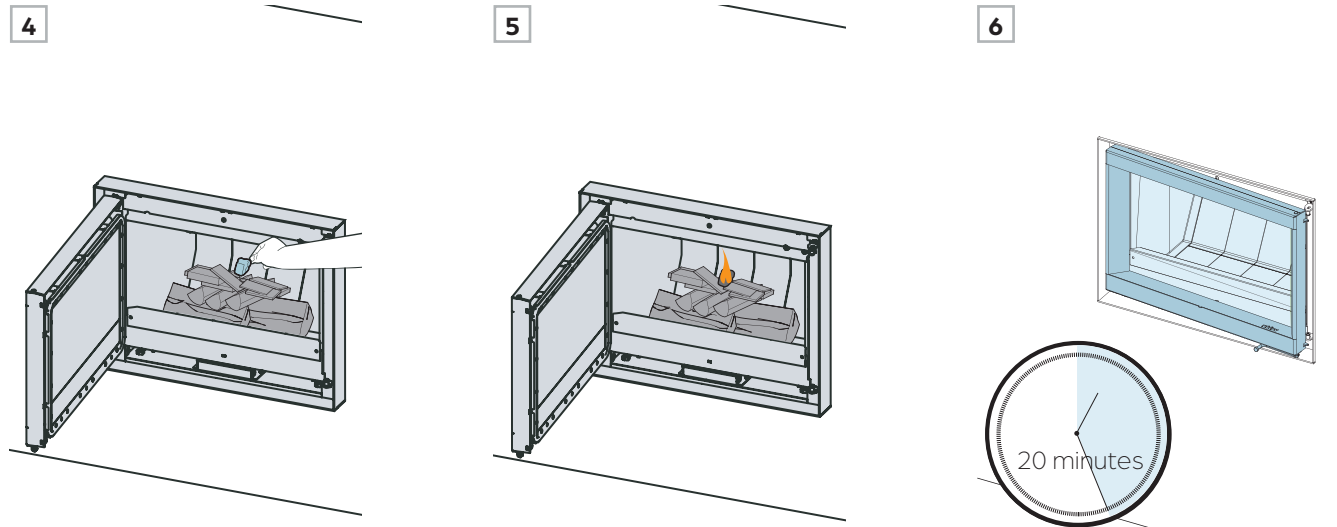
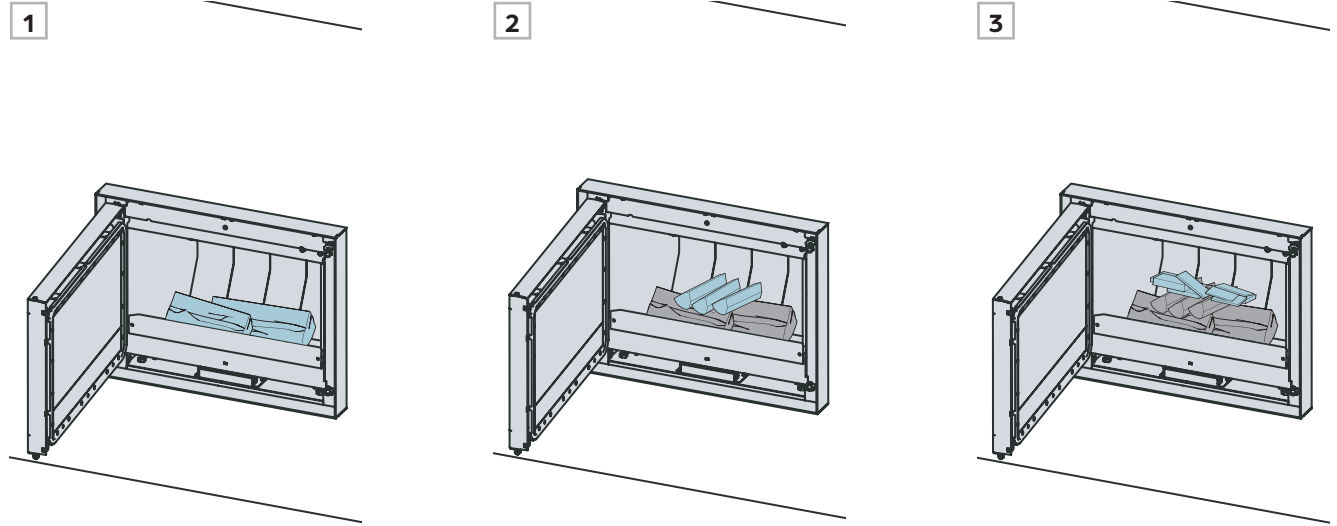

6.5 RELOADING THE FIRE



Step 1 Open the door.

Step 2 Add wood using the Stûv glove supplied with the unit. Do not stir or agitate the wood when it is burning.

Step 3 Close the door and enjoy the fire.

It is normal to feel resistance when opening the glass door when the fire is burning.



NOTE

The door can be kept ajar to help restart the fire.

1

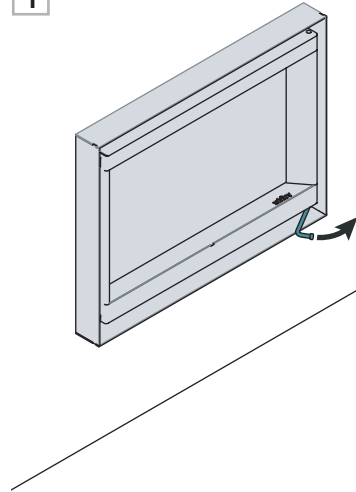

2



3

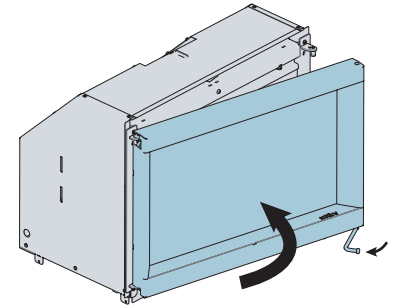

NOTE

Burning one log at a time increase the amount of embers and coal. While burning two or more logs, the combustion is optimized and this will reduce unburned residues.

6.6 ASH REMOVAL

Step 1 Wait until the ashes are cold before opening the door, to ensure safety. Remove ashes when they are above the angle bar.

Step 2 Use an ash shovel to remove the ashes and place them in a metal bucket **with a tight lid**. Wait until they are completely cold before disposing of them.

Step 3 Place the bucket filled with ashes on a non-combustible surface (not elevated). Be sure to keep it away from any combustible materials.

1

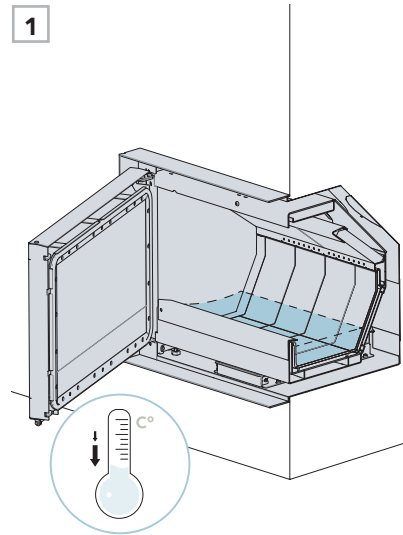

2

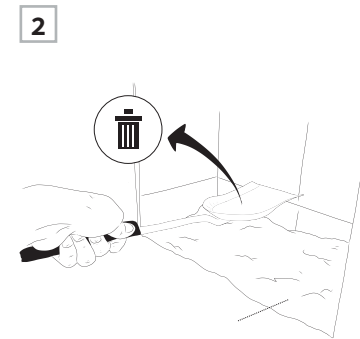

3

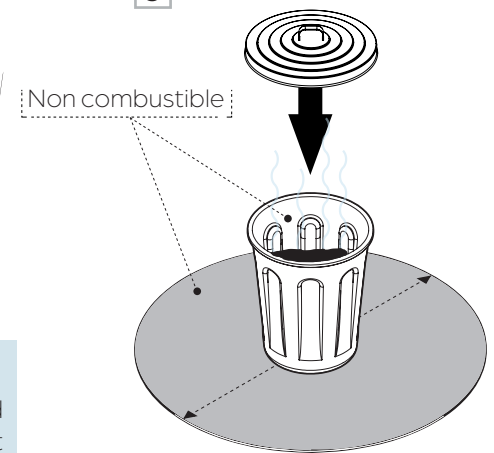

NOTE

Leaving 1" of ash bed after each use helps start the next fire.



7 MAINTENANCE

7.1	GLASS AND SEALS	42
7.2	CREOSOTE AND CHIMNEY-SWEEPING.....	42
7.3	COMPONENT REPLACEMENT	43

CLEANING THE GLASS

- Do not clean the door when the glass is hot.
- Using cleaning products will quickly degrade the seals. However, it is possible to use standard glass-cleaning products to clean the glass, on the inside and outside of the door.
- It is also possible to clean the glass using only water and ash.
- If the door is very dirty, it will be easier to remove it and place it on a soft surface in order to clean it.

Use a dry cloth to clean the components.

Note:

A spray paint can is supplied with the fireplace for touch-ups. When painting, do a test on another surface to avoid putting solvent on the existing paint. The surface to repaint must be smooth, clean and free of grease. Read the instructions on the spray paint can's label.

CHIMNEY-SWEEPING STEPS

Wait until the unit has cooled completely before conducting maintenance.

If sweeping is done **from the inside**:

- Open the door.
- Remove the top vermiculites.

If sweeping is done **from above**:

- Close the door.
- Carry out the sweeping according to local regulations.



Creosote is a thick, black residue that forms due to incomplete combustion of wood. It can be brittle or smooth (vitrified). During slow combustion, wood releases tar droplets that condense on the cold chimney lining. The shape of the residue varies with time and the internal temperature of the lining on which the creosote vapours condense.

This build-up of creosote can be very hazardous. When ignited, it produces an extremely hot fire in the chimney. Have your chimney professionally **inspected twice during the heating season** to assess whether or not a creosote build-up has occurred. If so, remove any built-up residue to **reduce the risk of a chimney fire**.

It is recommended that the unit's main user establish a chimney maintenance routine. Check for creosote build-up on a daily basis to get a good idea of how often the chimney needs to be swept for safety. The hotter a fire burns, the less creosote will build up. Weekly sweeping may be necessary in milder weather, while monthly sweeping can be sufficient during the colder months. **Contact your local or provincial fire department for information on how to put out a chimney fire.**



Inspect the combustion chamber three times per heating season to ensure its compliance.

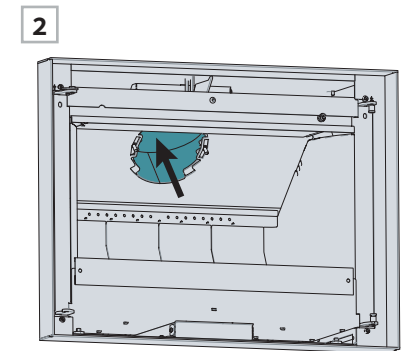
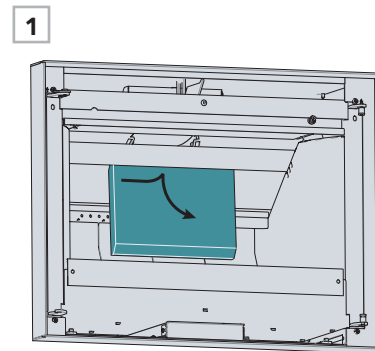



DOOR SEAL

Step 1 Visually inspect the seal to ensure it is in good condition. Even if it is, it might not be airtight enough to keep smoke from escaping.

Step 2 To check its airtightness, place a 3- or 4"-wide sheet of paper in the door and close. Try to pull the paper out all along the door frame. If the paper comes out, replace the seal. Contact the Stûv dealer.

! Stûv America recommends using **original replacement parts** to ensure the unit's integrity and safety.

Step 3 Remove the door and place it on a **clean, soft surface** to protect the paint.

Step 4 Tug on the door seal to remove.

Step 5 Push the new seal into place, positioning the junction at the bottom centre.

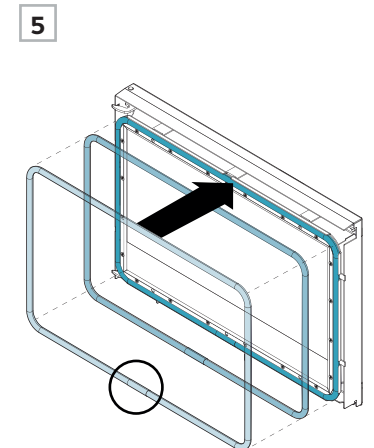
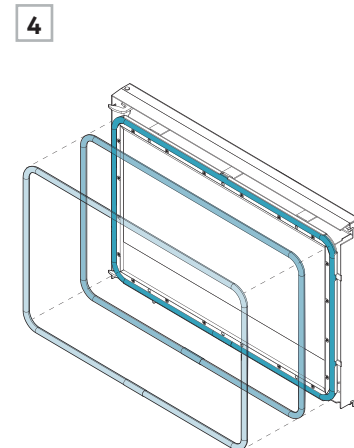
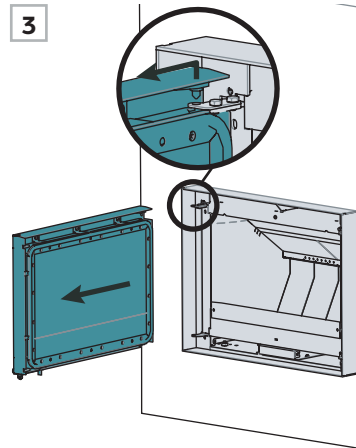
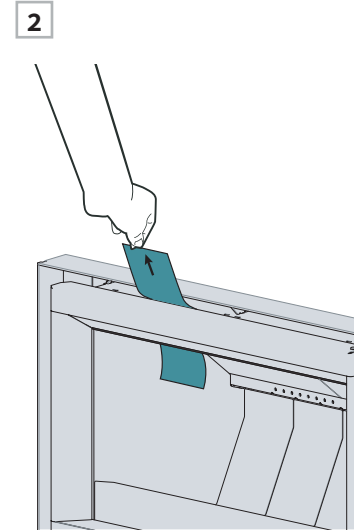
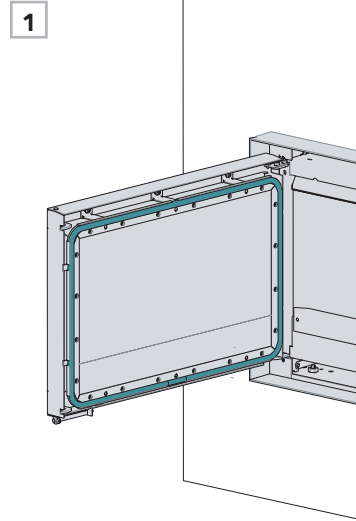



GLASS

Step 1 After removing the seal (see previous page), continue the steps by removing the screws on the glass retaining clips.

Step 2 Remove the glass retaining clips.

Step 3 The pane of glass is now accessible and can be changed. Repeat the steps in reverse to reassemble the door.

The glass must be a **4 mm**-thick ceramic glass and must be able to withstand high temperatures.

The glass has a specific shape for its purpose and **Stûv recommends the use of original replacement parts.**

1

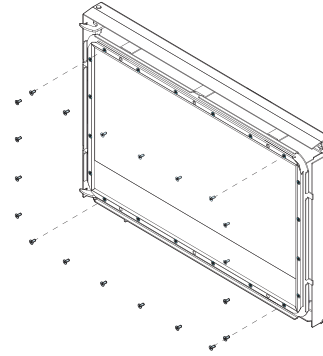

2

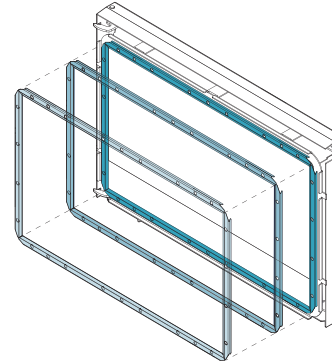

3

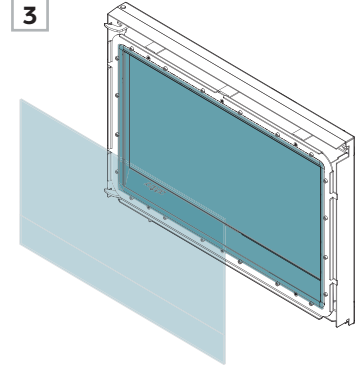

MODEL	DIMENSIONS
66x50	545 mm x 331 mm
76x55	645 mm x 381 mm
76x60	645 mm x 431 mm

GLASS SEAL

Step 4 Once the glass is removed, the seal will be accessible.

Step 5 The seal can be changed if it is damaged. If the pane is being changed, this seal must be changed as well.

Step 6 Repeat the steps in reverse up to reinstalling the door.

4

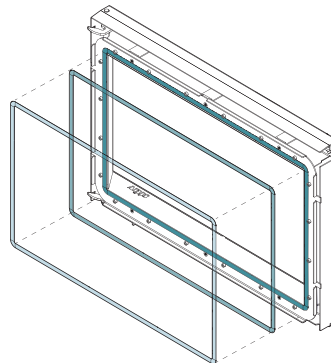

5

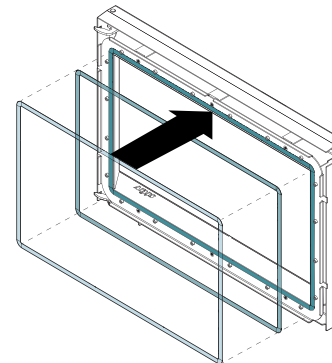

6

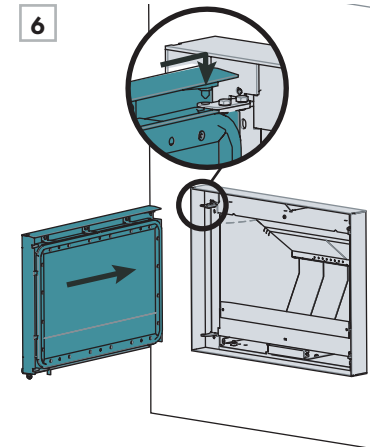

8

WARRANTY

8.1	WARRANTY DETAILS	46
8.2	WARRANTY FORM	47



8.1 WARRANTY DETAILS



WARRANTY COVERAGE

Stûv appliances are guaranteed against:

- manufacturing defects
- paint defects on the visible parts of the unit
- glass breakage, but only if it occurs during the first firing
- shipping-related damage if we are notified within 48 hours of delivery and the damage is noted on the carrier's bill of lading when the unit is received (website)

This warranty does not cover damage to the appliance or malfunctions due to:

- installation that does not comply with the applicable regulations or the installation instructions
- abnormal use that does not comply with the directions for use
- lack of maintenance
- an external cause, such as a flood, lightning strike, fire, etc.

The warranty is limited to replacing the parts deemed defective and does not include labour or damages.

WARRANTY TERMS

This document must be returned to us, duly completed, within one month of the date of the dealer's invoice to the buyer.

Duration of the warranty:

- 5 years on the body of the appliance
- 1 year on refractory materials, gaskets, door mechanism, hinges and latches.

The warranty period begins on the date of the dealer's invoice to the buyer. The replacement of parts under warranty does not extend the duration of the initial warranty.

When an item is defective, it is important to quickly notify an authorized Stûv dealer. They will contact Stûv America to fill out the warranty form. They will need:

- the unit's serial number
- the date the unit was purchased
- an explanation of the defective item
- photos of the defective item

With this information, Stûv America will be able to validate whether the part is covered by the warranty and judge the relevance of changing it. The dealer will also be in charge of installing the new part.

CERTIFICATE OF WARRANTY

This Stûv appliance has been designed to offer you maximum pleasure, comfort and safety. It has been manufactured with the utmost care using quality materials and components to provide years of trouble-free operation.

Should you notice a defect in spite of this care, we commit to rectifying the situation. However, as a user, you also have an important role to play in getting the satisfaction you expect from your Stûv.

We strongly recommend:

- having the unit installed by a qualified professional who can ensure that the installation of the appliance and the integrity of the chimney are in compliance with the certifications and the building code,
- carefully reading the operating and maintenance instructions,
- having the chimney swept regularly (once per heating season, for regular use) to ensure optimal operation and maximum safety.

8.2 WARRANTY FORM



THE APPLIANCE

Serial no.: _____

Model: _____

Invoice date: _____

Installation date: _____

*The serial number can be found on the marking label at the bottom of the combustion chamber. The location of the label is indicated on the first page of the *CERTIFICATION* section.

THE INSTALLER

I, the undersigned,
declare that the above-mentioned appliance has been installed in compliance with the existing regulations and in accordance with the technical recommendations in the installation instructions.

Date: _____

Signature: _____

Company: _____

Name: _____

Address: _____

Tel no.: _____

THE DEALER

Company: _____

Name: _____

Address: _____

Tel no.: _____

THE BUYER

Name: _____

Address: _____

Email: _____

Tel no.: _____

Installation address (if different): _____

PLEASE FILL OUT THIS FORM AND SEND IT TO US VIA:

Our website: **stuvamerica.com**
On the Warranty and Product Registration page

Stûv America Inc.
34, Boulevard de l'Aéroport
Bromont Québec J2L 1S6 Canada

Email: **info@stuvamerica.com**
Tel.: +1-866-487-7888
Fax: +1-514-528-9538



Stûv fireplaces are designed by:

Stûv sa – Belgique
stuv.com

Rue Jules Borbouse n°4 B-5170
Bois-de-Villers

And manufactured in North America by:

Stûv America inc. – Canada
stuvamerica.com

34, Boulevard de l'Aéroport
Bromont, QC Canada J2L 1S6

1-514-396-3463 | 1-866-487-7888