

Installation & Operating Manual

Installation and Appliance Setup - Care and Operation

INSTALLER: Leave this manual with party responsible for use and operation.

OWNER: Retain this manual for future reference.

Call your dealer for questions on Installation, Operation, or Service.

NOTICE: SAVE THESE INSTRUCTIONS

VERMONT  CASTINGS

Intrepid® Direct Vent Gas Heater

Model: INDVRBDSB, INDVRCBSB,
INDVR-IFT-CB, & INDVR-IFT-BD

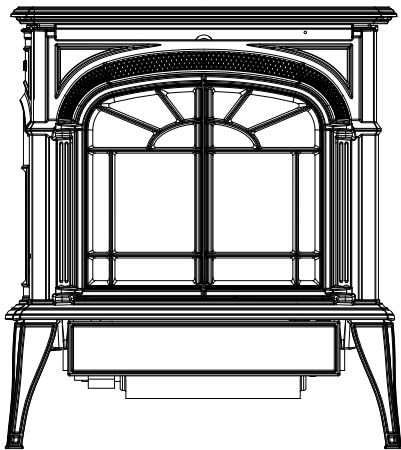

CERTIFIED
SAFETY BARRIER



Installation and service of this appliance should be performed by qualified personnel. Hearth & Home Technologies recommends HHT Factory Trained or NFI certified professionals.

hearthED
FACTORY TRAINING
Fuel Your Fire

NFI **NATIONAL**
FIREPLACE
INSTITUTE
A CERTIFICATION AGENCY

WARNING

FIRE OR EXPLOSION HAZARD

Failure to follow safety warnings exactly could result in serious injury, death or property damage.

- Do not store or use gasoline or other flammable vapors and liquids in the vicinity of this or any other appliance.
- **WHAT TO DO IF YOU SMELL GAS**
 - Do not try to light any appliance.
 - Do not touch any electrical switch; do not use any phone in your building.
 - Leave the building immediately.
 - Immediately call your gas supplier from a neighbor's phone. Follow the gas supplier's instructions.
 - If you cannot reach your gas supplier, call the fire department.
- Installation and service must be performed by a qualified installer, service agency or the gas supplier.



DANGER

**HOT GLASS WILL
CAUSE BURNS.**



**DO NOT TOUCH GLASS
UNTIL COOLED.**

**NEVER ALLOW CHILDREN
TO TOUCH GLASS.**

A barrier designed to reduce the risk of burns from the hot viewing glass is provided with this appliance and must be installed.

PLEASE READ THE INSTALLATION & OPERATING INSTRUCTIONS BEFORE USING APPLIANCE.

Thank you and congratulations on your purchase of a Vermont Castings stove. **IMPORTANT:** Read all instructions and warnings carefully before starting installation. Failure to follow these instructions may result in a possible fire hazard and will void the warranty.

Note: Cast iron is an artisan crafted material, which is made the same way today as nearly 2000 years ago. Due to the intrinsic primitive nature of the casting process, part to part variation is normal and adds to the character of a hand built cast iron appliance

Table of Contents

1 Important Safety Information	3	5 Cleaning and maintenance	51
A. Massachusetts Safety Information	4	A. Annual System Inspection.....	51
B. California Safety Information.....	4	B. Logset & Burner / Cleaning and Inspection.....	51
2 Framing and Clearances	5	C. Care of Cast Iron.....	51
A. Appliance Dimension Diagram.....	5	D. Glass Cleaning and Replacement.....	51
B. Installation Requirements.....	6	E. Gasket Replacement.....	52
C. Clearance Requirements	6	F. Inspect the Vent System Annually.....	52
→ D. Hearth Requirements.....	7	G. Check the Gas Flame Regularly	52
E. Clearances to Combustibles	7	6 Wiring Diagrams	53
F. Gas Specifications	8	7 Service Parts List	55
G. Vent Terminations & Clearances	8	8 Optional Accessories	62
H. Chimney Diagram	11	9 Warranty Policy	63
3 Assembly and Installation	13		
A. Venting Requirements & Options	13		
B. Assembling the Stove	14		
C. Venting System Assembly.....	14		
D. Log Set Installation.....	34		
E. Thermostat Connection.....	35		
F. INDVR-IFT Wiring Requirements.....	37		
G. Install the Safety Barrier.....	38		
H. Install the Mesh and Grill.....	38		
4 Operating Instructions	39		
A. Operation	39		
B. Lighting Instructions	39		
C. Pilot and Burner Inspection.....	39		
D. Flame Characteristics	39		
E. Flame & Temperature Adjustment.....	39		
F. Lighting and Operating Instructions (Millivolt ONLY).....	40		
G. Troubleshooting (Millivolt ONLY).....	41		
H. Read before lighting.....	42		
I. Lighting Instructions (IFT)	43		
J. Operation During a Power Outage - IntelliFire™ Touch	44		
K. Detailed Component Operating Instructions IntelliFire™ Touch.....	45		
L. Frequently Asked Question IntelliFire™ Touch Controls (IFT-RC400).....	47		
M. Troubleshooting.....	48		
N. Burner, Pilot & Control Compartment.....	50		

→ = Contains updated information

1 Important Safety Information

A. Massachusetts Safety Information

The Intrepid DV Direct Vent Room Heater, Model Nos. INDVRBDSB, INDVRCBSB, INDVR-IFT-CB, & INDVR-IFT-BD, is a vented gas appliance listed to the ANSI Standard Z21.88-2019 and CSA 2.33-2019 for Vented Room Heaters, and CSA 2.17-M91, Gas-Fired Appliances For Use at High Altitudes.

The installation of the Intrepid DV Direct Vent Room Heater must conform with local codes, or in the absence of local codes, with National Fuel Gas Code, ANSI Z223.1/NFPA 54 — latest edition and CSA B-149.1 Installation Code. (EXCEPTION: Do not derate this appliance for altitude. Maintain the manifold pressure at 3.5 inches w.c. for Natural Gas and 10 inches w.c. for LP gas at maximum input.)

This appliance is only for use with the type of gas indicated on the rating plate. This appliance is not convertible for use with other gases unless a certified kit is used.

Installation and replacement of gas piping, gas utilization equipment or accessories, and repair and servicing of equipment shall be performed only by a qualified agency, preferably NFI or WETT (Canada) certified. The term “qualified agency” means any individual, firm, corporation, or company that either in person or through a representative is engaged in and is responsible for (a) installation or replacement of gas piping, or (b), the connection, installation, repair, or servicing of equipment, who is experienced in such work, familiar with all precautions required, and has complied with all the requirements of the authority having jurisdiction.

The Intrepid DV Direct Vent Room Heater should be inspected before use and at least annually by a qualified service agency. It is imperative that control compartments, burners, and circulating air passageways of the appliance be kept clean.

The Intrepid DV Direct Vent Room Heater and its individual shut-off valve must be disconnected from the gas supply piping during any pressure testing of that system at test pressures in excess of 1/2 psig (3.5 kPa).

The Intrepid DV Direct Vent Room Heater must be isolated from the gas supply piping system by closing its individual manual shutoff valve during any pressure testing of the gas supply piping system at test pressures equal to or less than 1/2 psig.

An accessible tap is located above the pilot/On-Off knob for checking the inlet pressure.

‘Direct Vent’ describes a sealed combustion system in which incoming outside air for combustion and outgoing exhaust enter and exit through two separate concentric passages within the same sealed vent system. The system does not use room air to support combustion. The Direct Vent system permits the gas appliance to be vented directly to the outside atmosphere through the side of the house or vertically through the roof. Conventional venting systems (Natural Vent) take air from the room for combustion and vent the exhaust vertically through the roof to the atmosphere.

This appliance is approved for bedroom installations in the U.S. and Canada.

This appliance may be installed in an aftermarket* manufactured (mobile) home, where not prohibited by state or local codes.

WARNING: Operation of this heater when not connected to a properly installed and maintained venting system can result in carbon monoxide (CO) poisoning and possible death.

The Intrepid DV Direct Vent Room Heater, when installed, must be electrically grounded in accordance with local codes or, in the absence of local codes, with the National Electrical Code ANSI/NFPA 70, (latest edition), or of the current Canadian Electrical Code C22.1.

Due to high temperatures this appliance should be located out of traffic and away from furniture and draperies.

WARNING: This appliance is hot while in operation. Keep children, clothing, and furniture away. Contact may cause burns or ignition of combustible materials.

Children and adults should be alerted to the hazards of high surface temperatures and should stay away to avoid burns or clothing ignition.

Young children should be carefully supervised when they are in the same room as the appliance. Toddlers, young children and others may be susceptible to accidental contact burns. A physical barrier is recommended if there are at risk individuals in the house. To restrict access to a stove or stove, install an adjustable safety gate to keep toddlers, young children and other at risk individuals out of the room and away from hot surfaces.

A barrier is designed to reduce the risk of burns from the hot viewing glass is provided with this appliance and shall be installed for the protection of children and other at-risk individuals.

If the barrier becomes damaged, the barrier shall be replaced with the manufacturer’s barrier for this appliance.

Clothing or other flammable materials should not be placed on or near the appliance.

Any safety screen, glass or guard removed for servicing an appliance must be replaced prior to operating the appliance.

The appliance area must be kept clear and free from combustible materials, gasoline, and other flammable vapors and liquids.

The flow of combustion and ventilation air must not be obstructed. The installation must include adequate accessibility and clearance for servicing and proper operation.

WARNING: Do not operate the Room Heater with the glass panel removed, cracked or broken. Replacement of the panel should be done by a licensed or qualified service person.

Do not use this appliance if any part has been under water. Immediately call a qualified service technician to inspect the appliance and to replace any part of the control system and any gas control which has been under water.

Do not burn wood, trash or any other material for which this appliance was not designed. This appliance is designed to burn either natural gas or propane only.

This gas appliance must not be connected to a chimney flue serving a separate solid-fuel burning appliance.

CAUTION: Label all wires prior to disconnection when servicing controls. Wiring errors can cause improper and dangerous operation.

Verify proper operation after servicing.

** Aftermarket: Completion of sale, nor for purpose of resale, from the manufacturer.*

Requirements for the Commonwealth of Massachusetts

All gas fitting and installation of this heater shall only be done by a licensed gas fitter or licensed plumber.

For all side wall horizontally vented gas fueled equipment installed in every dwelling, building or structure used in whole or in part for residential purposes, including those owned or operated by the Commonwealth and where the side wall exhaust vent termination is less than seven (7) feet above finished grade in the area of the venting, including but not limited to decks and porches, the following requirements shall be satisfied:

Installation of Carbon Monoxide Detectors

At the time of installation of the side wall horizontal vented gas fueled equipment, the installing plumber or gas fitter shall observe that a hard wired carbon monoxide detector with an alarm is installed on each additional level of the dwelling, building or structure served by the side wall horizontal vented gas fueled equipment. It shall be the responsibility of the property owner to secure the services of qualified licensed professionals for the installation of hard wired carbon monoxide detectors.

In the event that the side wall horizontally vented gas fueled equipment is installed in a crawl space or an attic, the hard wired carbon monoxide detector with alarm and battery back-up may be installed on the next adjacent floor level.

In the event that the requirements of this subdivision can not be met at the time of completion of installation, the owner shall have a period of thirty (30) days to comply with the above requirements; provided, however, that during said thirty (30) day period, a battery operated carbon monoxide detector with an alarm shall be installed.

Approved Carbon Monoxide Detectors

Each carbon monoxide detector as required in accordance with the above provisions shall comply with NFPA 720 and ANSI/UL 2034 listed and IAS certified.

Signage

A metal or plastic identification plate shall be permanently mounted to the exterior of the building at a minimum height of eight (8) feet above grade directly in line with the exhaust vent terminal for the horizontally vented gas fueled heating appliance or equipment. The sign shall read, in print size no less than one-half (1/2) inch in size, "GAS VENT DIRECTLY BELOW, KEEP CLEAR OF ALL OBSTRUCTIONS".

**Intrepid DV Direct Vent
Certified to: ANSI Z21.88-2019 / CSA 2.33-2019 Vented
Gas Heaters**

Inspection

The state or local gas inspector of the side wall horizontally vented gas fueled equipment shall not approve the installation unless, upon inspection, the inspector observes carbon monoxide detectors and signage installed in accordance with the provisions of 248 CMR 5.08(2)(a)1 through 4.

Exemptions

The following equipment is exempt from 248 CMR 5.08(2)(a)1 through 4:

- The equipment listed in Chapter 10 entitled "Equipment Not Required To Be Vented" in the most current edition of NFPA 54 as adopted by the Board; and
- Product Approved side wall horizontally vented gas fueled equipment installed in a room or structure separate from the dwelling, building or structure used in whole or in part for residential purposes.

Manufacturer Requirements

Gas Equipment Venting System Provided

When the manufacturer of Product Approved side wall horizontally vented gas equipment provides a venting system design or venting system components with the equipment, the instructions provided by the manufacturer for installation of the equipment and the venting system shall include:

- Detailed instructions for the installation of the venting system design or the venting system components; and
- A complete parts list for the venting system design or venting system.

Gas Equipment Venting System NOT Provided

When the manufacturer of a Product Approved side wall horizontally vented gas fueled equipment does not provide the parts for venting the flue gases, but identifies "special venting systems", the following requirements shall be satisfied by the manufacturer:

- The referenced "special venting system" instructions shall be included with the appliance or equipment installation instructions; and
- The "special venting systems" shall be Product Approved by the Board, and the instructions for that system shall include a parts list and detailed installation instructions.

A copy of all installation instructions for all Product Approved side wall horizontally vented gas fueled equipment, all venting instructions, all parts lists for venting instructions, and/or all venting design instructions shall remain with the appliance or equipment at the completion of the installation.

B. California Safety Information



WARNING

This product and the fuels used to operate this product (liquid propane or natural gas), and the products of combustion of such fuels, can expose you to chemicals including benzene, which is known to the State of California to cause cancer and reproductive harm. For more information go to: www.P65Warnings.ca.gov.

2 Framing and Clearances

A. Appliance Dimension Diagram

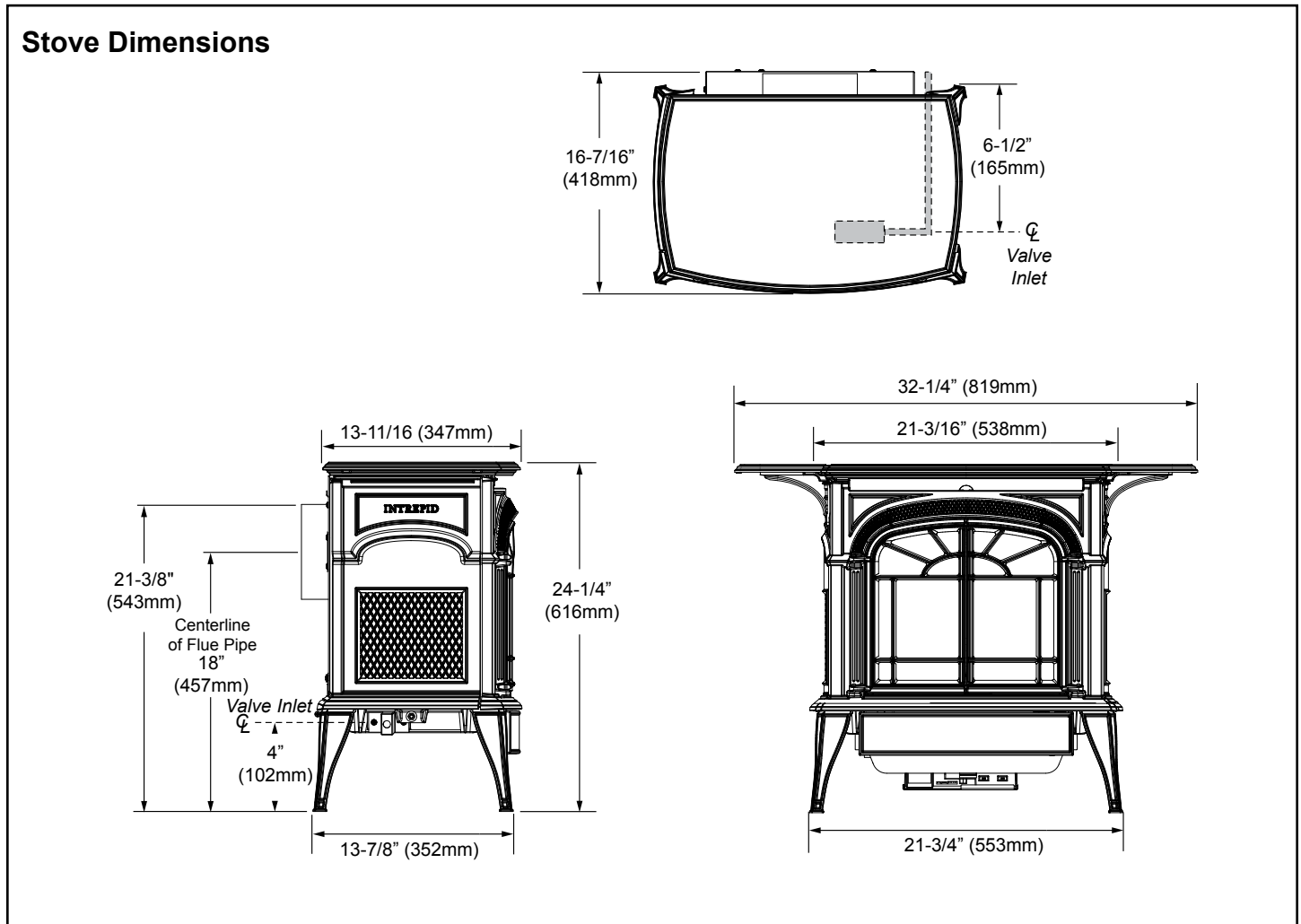

Figure 2.1 - Intrepid DV dimensions.

B. Installation Requirements

The installation must conform with local codes or, in the absence of local codes, with the National Fuel Gas Code, ANSI Z223.1/NFPA 54 - latest edition. (EXCEPTION: Do not derate this appliance for altitude. Maintain the manifold pressure at 3.5" w.c. for Natural Gas, and 10" w.c. for Propane).

In Canada, installation must be in accordance with the current CSA B-149.1 Installation Codes and/or local codes.

The installation should be done by a qualified service person who is familiar with the building codes and installation techniques appropriate for your area to accomplish a safe and effective installation.

Your dealer or your local gas supplier will be able to refer a qualified service person.



WARNING

Due to high temperatures, the heater should be located out of traffic and away from furniture and draperies.

The surface of the Heater is hot when it is in use. Young children should be watched carefully when they are in the same room when the Heater is in use, and they should be taught to avoid the hot surface. Keep any objects that can burn well away from the Heater, and observe the recommended clearances that follow.



WARNING

Improper installation, adjustment, alteration, service or maintenance can cause injury or property damage. Refer to this manual. For assistance or additional information consult a qualified installer, service agency or the gas supplier.

In choosing a location for the stove, consider:

- The location of outside walls;
- Where additional heat is needed;
- Where family members gather most often;
- The vent system requirements.

NOTE: We do not recommend the use of wallpaper next to this stove. Over time, radiant heat may cause the wallpaper to shrink, or may adversely affect the binders in the wallpaper adhesive.

This appliance may be installed in an aftermarket,* permanently located, manufactured home (USA only) or mobile home, where not prohibited by local codes. This appliance is for use only with the type of gas indicated on the rating plate. This appliance is not convertible for use with other gases, unless a certified kit is used.

* Aftermarket: Completion of sale, not for purpose of resale, from the manufacturer.

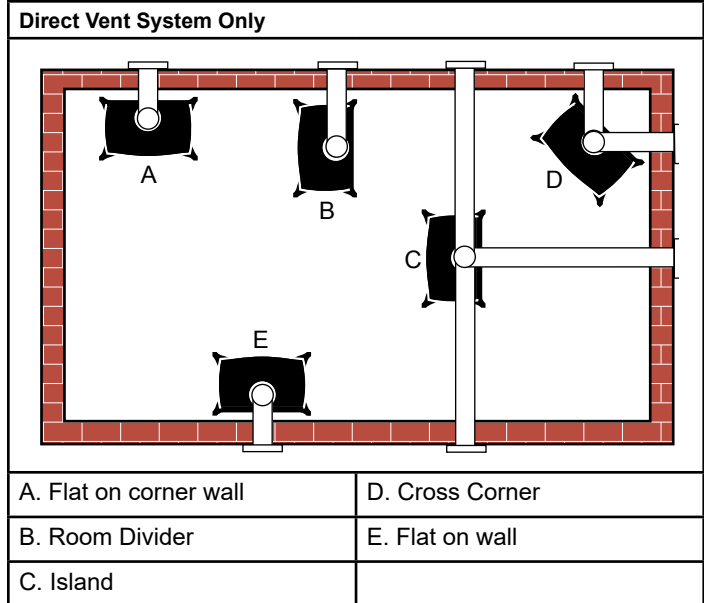

Figure 2.2 - Possible stove locations.

C. Clearance Requirements

Minimum Clearances to Combustible Materials

Measure side clearances as shown in Figures 2.3 thru 2.6 from the outer edge of the cast iron stove top. Measure rear clearances from the outermost surface of the steel rear skirt.

The Intrepid DV heater is approved for installation into an alcove constructed of combustible materials to the dimensions and clearances shown on the next page.

The same clearances apply in a standard parallel installation.



WARNING

Always maintain minimum clearances around vent systems. Rear/Top Vent Vertical Side wall: Horizontal sections of this vent system require a minimum of 3" (76 mm) clearances to combustibles at the top of the flue and 1" (25 mm) clearance at the sides and bottom until the flue penetrates the outside wall. A minimum 1" clearance all around the flue is acceptable at this point of penetration. If vertical rise is 7-1/2 feet (2.3 m) or higher when top venting, the clearance to combustibles is 1" on all sides of the horizontal run. FOR VERTICAL RUNS ONLY, maintain a 1" (25 mm) minimum clearance to all sides. Do not pack the open air spaces around the stove or flue with insulation or other materials. Any horizontal run must have a 1/4" rise for every one (1) foot of run towards the vent termination. Never run the vent level or down.

D. Hearth Requirements



CAUTION

Hearth and Home Technologies does not recommend adhesive based vinyl flooring due to thermal expansion. Floating-style flooring (LVP - luxury vinyl plank or LVT - luxury vinyl tile) can be used, but it will reach temperatures up to 110 °F in a room with ambient temperature of 70 °F. Consult flooring specifications to ensure compatibility.

When using LVP/LVT flooring, gas stoves require 6 inches of alternative flooring in front of the stove before using LVP/LVT. Whether the stove sits flush on the floor or is elevated on a raised hearth, 6 inches of alternative flooring is required in front of the stove or insert.

For all other flooring, continue to follow clearance to combustible requirements in the installation manual.

NOTICE: Clearances that do not meet the minimum guidelines could result in damage or buckling to the vinyl flooring and is done at the installer's risk.

The Intrepid DV Heater can be installed on any type of rigid flooring (e.g. hardwood, ceramic tile, brick, etc). When the heater is installed on a carpeted surface, a metal or wooden panel extending the full width and depth of the unit must be used as the hearth. The purpose of the hearth is to prevent the unit from sinking into the carpet surface and reducing the required clearance to the underside of the unit. There are no other hearth requirements.

E. Clearances to Combustibles

Parallel Installation: Minimum Clearance

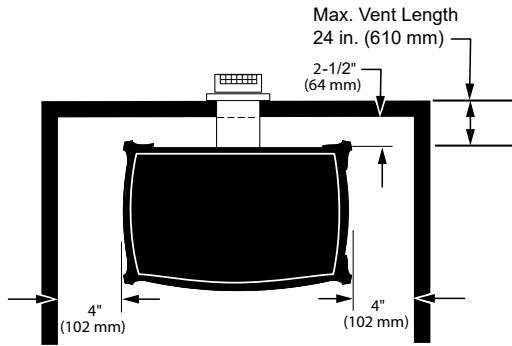

Figure 2.3 - Parallel installation, minimum back and side clearances.

Corner Installation: Minimum Clearance

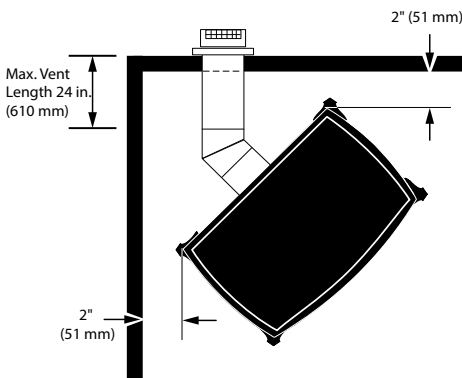

Figure 2.4 - Corner installation, minimum corner clearances.

Wall and Ceiling Clearances

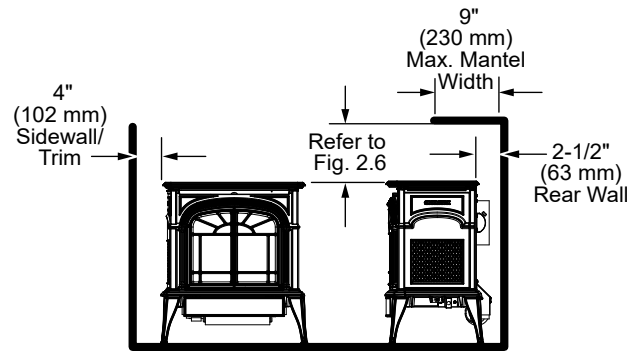
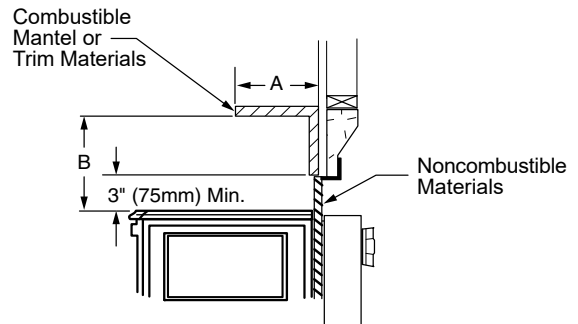

Figure 2.5 - Wall and Ceiling Clearances.

Mantel Clearances



A (Maximum)	B (Minimum)
9" (230 mm)	10-1/2" (270 mm)
7-1/2" (190 mm)	9" (230 mm)
6" (152 mm)	7-1/2" (190 mm)
4-1/2" (114 mm)	6" (152 mm)
3" (76 mm)	4-1/2" (114 mm)
1-1/2" (38 mm)	3" (76 mm)

A = Depth of Mantel and/or Top Trim
B = Height from Top of Heater

Figure 2.6 - Mantel Clearances

Alcove Clearances

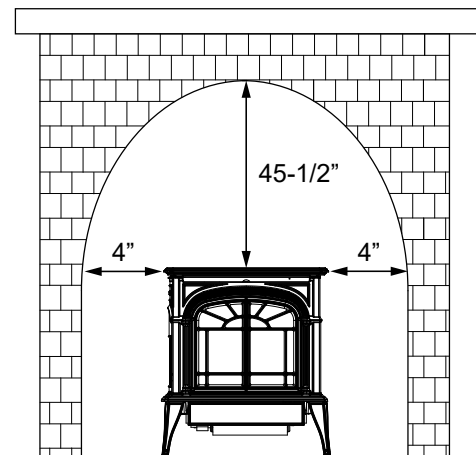

Min. Height = 69-3/4", Min. Width = 33-3/16", Max. Depth = 18-15/16"

Figure 2.7 - Alcove Clearances

F. Gas Specifications

Gas Specifications				
Model	Fuel	Gas Control	Max. Input BTU/h	Min. Input BTU/h
INDVR Series	Nat	Millivolt	17,000	12,500
INDVR Series	LP	Millivolt	16,000	12,000
INDVR-IFT	Nat	IFT	17,000	12,500
INDVR-IFT	LP	IFT	16,000	12,000

Air Shutter Setting Minimum injector air inlet opening		
Model	Natural Gas	LP (Propane)
INDVR Series	1/2 Open	1/2 Open

Gas Inlet and Manifold Pressures		
	Natural Gas	LP (Propane)
Inlet Minimum	5.0" W.C.	11.0" W.C.
Inlet Maximum	14.0" W.C.	14.0" W.C.
Manifold Pressure	3.5" W.C.	10" W.C.

The installation must conform with local codes or, in the absence of local codes, with the National Fuel Gas Code, ANSI Z223.1/NFPA 54 - latest edition. (EXCEPTION: Do not derate this appliance for altitude. Maintain the manifold pressure at 3.5" w.c. for Natural Gas and 10" w.c. for Propane.)

High Elevations

Input ratings are shown in BTU per hour and are certified without deration for elevations up to 4,500 feet (1,370m) above sea level.

For elevations above 4,500 feet (1,370m) in USA, installations must be in accordance with the current ANSI Z223.1/NFPA 54 and/or local codes having jurisdiction.

In Canada, please consult provincial and/or local authorities having jurisdiction for installations at elevations above 4,500 feet (1,370m).



WARNING

Improper installation, adjustment, alteration, service or maintenance can cause injury or property damage. Refer to this manual for correct installation and operational procedures. For assistance or additional information consult a qualified installer, service agency, or the gas supplier.

G. Vent Terminations & Clearances

Horizontal Termination

Except for straight-through the wall vent installations. The vent must rise vertically a minimum of 24" (610 mm) after the first elbow directly off the back of the unit, before the next elbow. The horizontal run may extend up to 20' (6 m) and include a vertical rise of up to 40' (12 m), Figure 2.8.

- Horizontal termination must also meet the criteria shown in Figures 2.10 and 2.11.
- Approved vent systems must terminate above and including the heavy line, Figure 2.8.
- Two 45° elbows may be substituted for each single 90° elbow.
- With a rise between 2' - 5', one 90° or two 45° elbows may be used (Excluding the first elbow directly off the back of the unit).
- 24" maximum horizontal termination directly off back.
- Corner installation using 45° elbow, maximum horizontal after elbow is 24 inches.

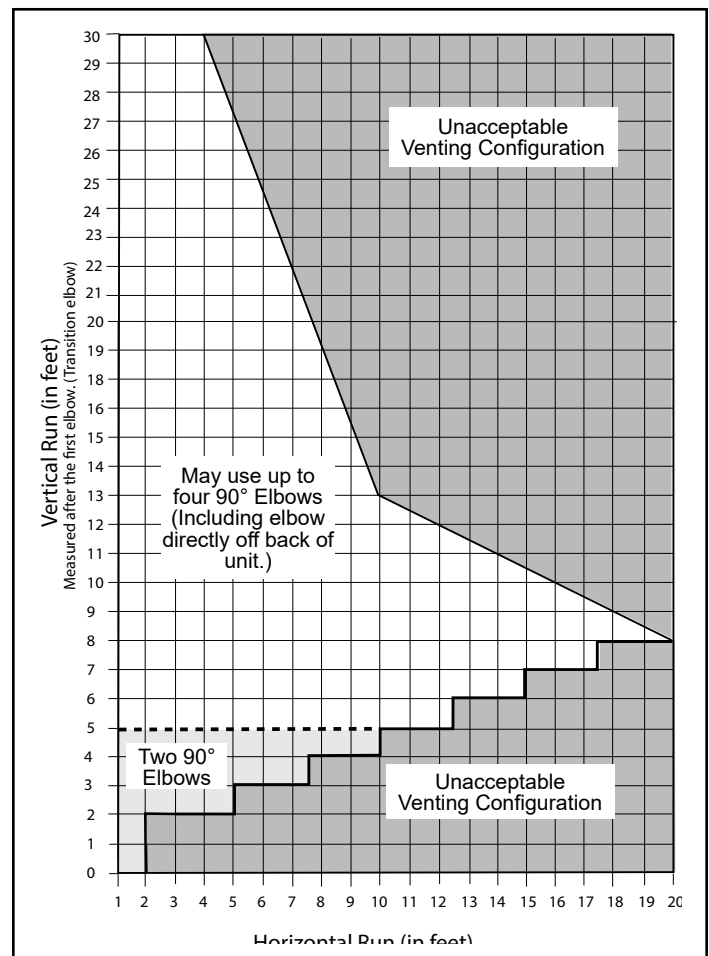

Figure 2.8 - Horizontal vent termination window.

Vertical Termination

A vertical vent system must terminate no less than 8' (2.44 m) and no more than 40' (12 m) above the appliance flue collar. There is a restrictor plate installed in the stove from the factory. An extra vent restrictor plate (included in the manual bag) can be added within the venting to reduce draft in a high draft situation. Fine tune adjustments can be made to compensate for draft characteristics that could interfere with proper flame height and operation. **Note:** There is no adjustability within the firebox for high draft situations.

A vertically terminated vent system must also conform to the following criteria:

- No more than four 90° elbows may be used.
- Two 45° elbows may be substituted for one 90° elbow. No more than six 45° elbows may be used.
- Vent must rise a minimum of 2 feet (305 mm) before offset is used.
- Termination height must conform to roof clearance as specified in Figure 2.9.

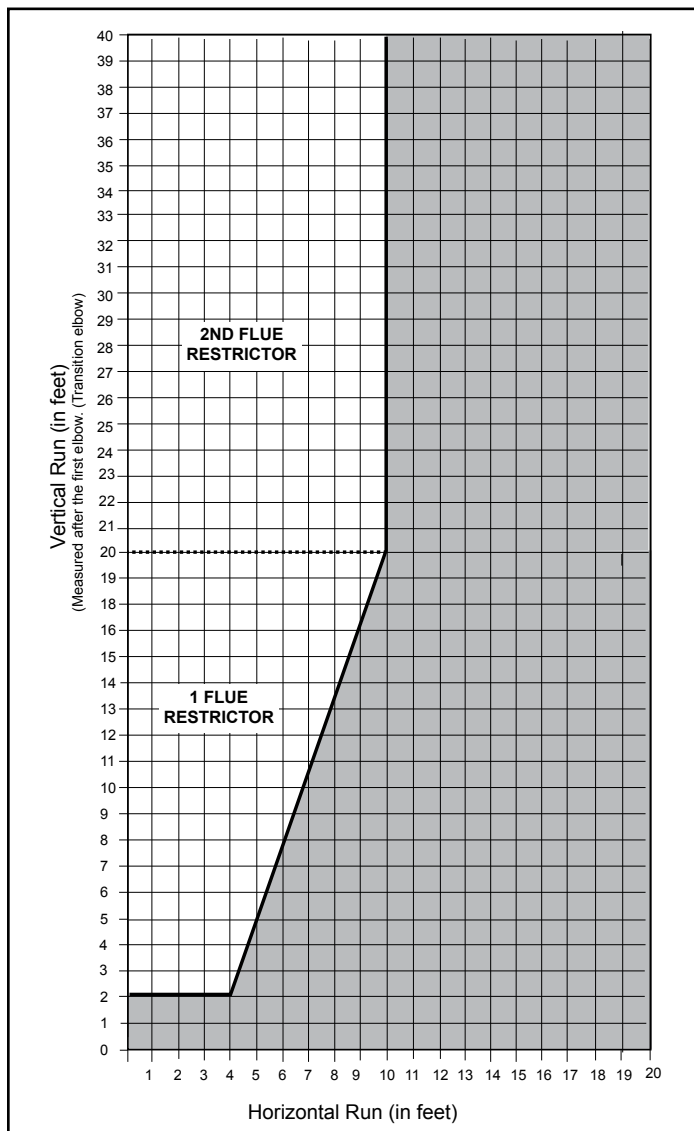

Figure 2.9 - Vertical vent termination window.

Vent Termination Clearances

When planning the installation, consider the location of the vent terminal and clearances. Some of the most common clearances to keep in mind are shown in Figure 2.10.

Important: All vent clearances must be maintained. Check your vent termination clearances against Figures 2.10 and 2.11.

The vent should be placed so that people cannot be burned by accidentally touching the vent surfaces when the stove is operating.

The vent termination should be located where it cannot be damaged by such things as automobile doors, lawn mowers or snowblowers and it should be located away from areas where it could become blocked by snow, etc.

Some considerations are:

- Obstructions or impediments to venting.
- Nearby combustible materials that could come into contact with combustion exhaust gases.
- Other nearby openings {within 12" (305 mm)} through which exhaust gas could reenter the building.
- All vegetation within 3' (76 mm) that may interfere with the draft.

Other factors that influence where the installation will be sited include the location of outside walls, where additional heat may be desired in the home, where the family members gather most regularly, and perhaps most importantly, the distance limitations of the venting system.

IMPORTANT

The horizontal termination must not be recessed into the exterior wall or siding.

Horizontal vent runs must be level toward the vent termination.

Clearances around the vent termination must be maintained.

For installations using DuraVent pipe, parallel installations with minimum wall clearance have restricted access for connecting the Horizontal Vent Cap straps to the vent pipe. See the maker's instructions for recommended installation procedures.

Your stove is approved to be vented either through the side wall, or vertical through the roof.

- HHT does not require any opening for inspection of vent pipe.
- Only HHT SLP venting components or DuraVent venting components specifically approved and labeled for this stove may be used.
- Maintain minimum clearances between vent pipes and combustible materials.
- Venting terminals shall not be recessed into a wall or siding.
- Any horizontal run must have a 1/4" rise for every one (1) foot of run towards the vent termination. Never run the vent level or down.

There must not be any obstruction such as bushes, garden sheds, fences, decks or utility buildings within 24" from the front of the termination hood.

Do not locate termination hood where excessive snow or ice build up may occur. Be sure to check vent termination area after snow falls, and clear to prevent accidental blockage of venting system. When using snow blowers, make sure snow is not directed towards vent termination area.

Location of Vent Termination

It is imperative the vent termination be located observing the minimum clearances as shown in this manual.

H. Chimney Diagram

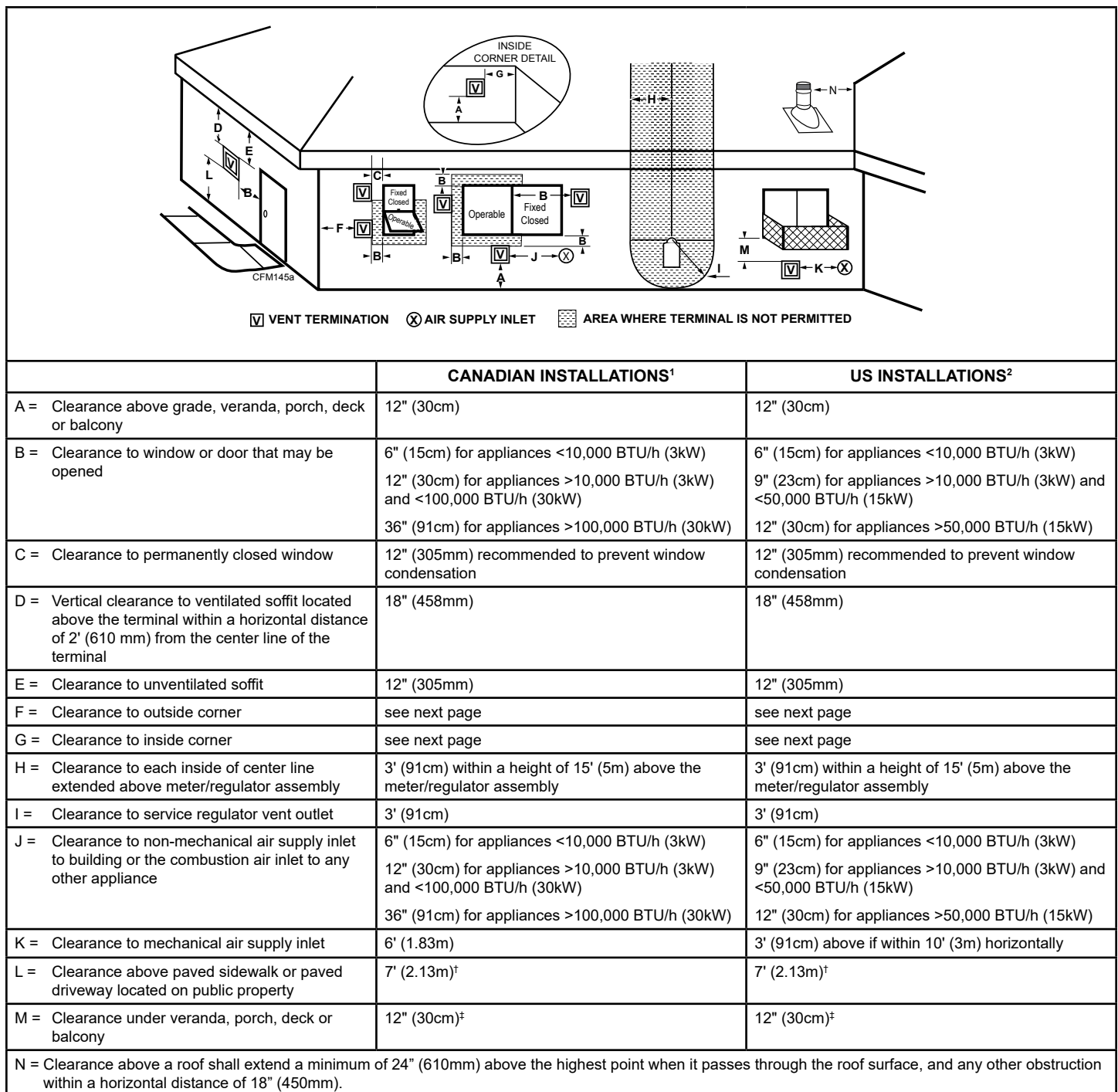

Figure 2.10 - Vent termination clearances.

1. In accordance with the current CSA-B149 Installation Codes
 2. In accordance with the current ANSI Z223.1/NFPA 54 National Fuel Gas Codes
- † A vent shall not terminate directly above a sidewalk or paved driveway which is located between two single family dwellings and serves both dwellings
- ‡ Only permitted if veranda, porch, deck or balcony is fully open on a minimum 2 sides beneath the floor.

NOTE:

1. Local codes or regulations may require different clearances.
2. The special venting system used on Direct Vent Fireplaces are certified as part of the appliance, with clearances tested and approved by the listing agency.
3. HHT assumes no responsibility for the improper performance of the appliance when the venting system does not meet these requirements.

Termination Clearances

Termination clearances for buildings with combustible and noncombustible exteriors.

Inside Corner

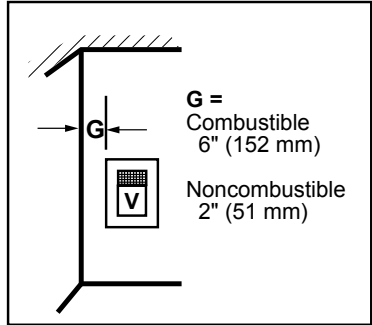

Outside Corner

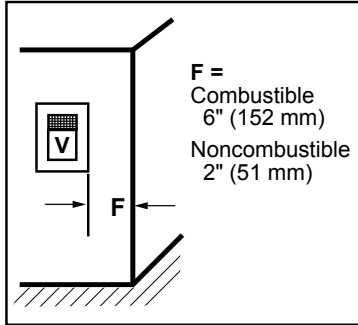

Alcove Applications*

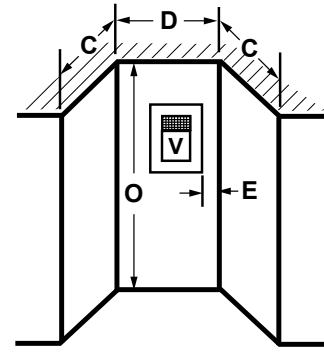

E = Min. 2" (51 mm) for non-vinyl sidewalls
 Min. 12" (305 mm) for vinyl sidewalls
O = 8' (2.4 m) Min.

Balcony - with no side wall

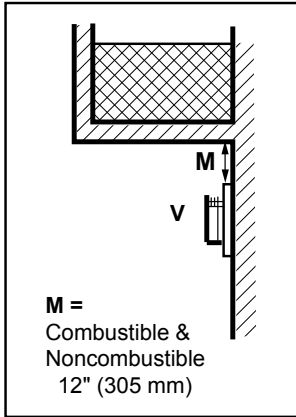

Balcony - with perpendicular side wall

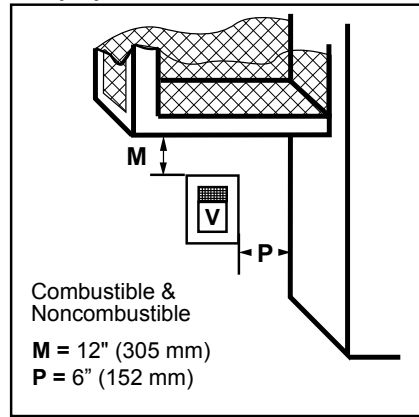

# of Caps	$D_{Min.}$	$C_{Max.}$
1	3' (914 mm)	$2 \times D_{Actual}$
2	6' (1.8 m)	$1 \times D_{Actual}$
3	9' (2.7 m)	$2/3 \times D_{Actual}$
4	12' (3.7 m)	$1/2 \times D_{Actual}$

$D_{Min.} = \# \text{ of Termination caps} \times 3$
 $C_{Max.} = (2 / \# \text{ termination caps}) \times D_{Actual}$

***NOTE:** Termination in an alcove space (spaces open only on one side and with an overhang) is permitted with the dimensions specified for vinyl or non-vinyl siding and soffits.

1. There must be a 3' (914 mm) minimum between termination caps.
2. All mechanical air intakes within 10' (1 m) of a termination cap must be a minimum of 3' (914 mm) below the termination cap.
3. All gravity air intakes within 3' (914 mm) of a termination cap must be a minimum of 1' (305 mm) below the termination cap.

Figure 2.11 - Termination clearances.

3 Assembly and Installation

A. Venting Requirements & Options

Approved Vent System Components

The Intrepid DV Heater must be vented to the outdoors through an adjacent exterior wall or through the roof. The venting system must be comprised of the appropriate listed venting components specified on this page. These parts are available from DuraVent Corporation or your Vermont Castings Dealer.

See Figure 2.4 for dimensions relevant to the standard minimum-vent kits.

HHT Components*

Stove Adapter Kit (Includes 30' of 4" Flex, adapters, wall thimble, masonry and ZC flashing, 991DA Cap and Fasteners)	LINK-STOVE
Trapezoid Termination Kit (3-1/8" - 4-3/4")	SLP-TRAP1
Trapezoid Termination Kit (5-1/4" - 9-1/4")	SLP-TRAP2
Rear Vent Termination Kit	SLP-RVTK
Vertical Termination cap – High Wind (includes storm collar)	SLP-TVHW
Decorative Wall Thimble Cover	SLP-WT-BK
Decorative ceiling firestop – black	SLP-DCF-BK
Cathedral ceiling support – black	SLP-CCS-BK
4" (100mm) pipe length – black	SLP4-BK
6" (150mm) pipe length – black	SLP6-BK
12" Pipe length-black	SLP12-BK
24" Pipe length-black	SLP24-BK
36" (915mm) pipe length – black	SLP36-BK
48" Pipe length-black	SLP48-BK
3" - 6" (75 – 150mm) telescoping pipe extension – black	SLP6A-BK
3" - 12" telescoping pipe extension-black	SLP12A-BK
45 degree elbow-black	SLP45-BK
90 degree elbow-black	SLP90-BK
SL Snorkel Cap (Includes 1 pair of firestops)	SLK-SNKD

DuraVent Components

90° Elbow, Blk.	46DVA-E90B
45° Elbow, Gal.	46DVA-E45
6" Straight, Blk.	46DVA-06B
9" Straight, Blk.	46DVA-09B
11" – 14 ^{5/8} " Adjustable Straight Section	46DVA-08AB
12" Straight	46DVA-12
24" Straight	46DVA-24B
36" Straight	46DVA-36B
48" Straight	46DVA-48
Horizontal Vent Cap	46DVA-HC
Wall Plate	46DVA-DC
Vinyl Siding Shield	46DVA-VSS
Snorkel Termination – 14"	46DVA-SNK14
Snorkel Termination – 36"	46DVA-SNK30
Wall Strap	46DVA-WS
Cathedral Ceiling Support Box	46DVA-CS
Storm Collar	46DVA-SC
Firestop Spacer	46DVA-FS
Flashing 0/12 - 6/12	46DVA-F6
Flashing 6/12 - 12/12	46DVA-F12
Wall Thimble	46DVA-WT
Wall Thimble Cover (Brass)	3PVP-TKV
Wall Firestop	46DVA-WFS
Attic Installation Shield	46DVA-IS
Co-Linear Vent Adapter	46DVA-GCL
Steel Chimney Conv. Kit A (6-5/8" - 8-5/8")	46DVA-KCA
Steel Chimney Conv. Kit B (6-5/8" - 10-1/2")	46DVA-KCB
Steel Chimney Conv. Kit C (6-5/8" – 13")	46DVA-KCC
Masonry Chimney Conversion Kit	46DVA-KMC
Vertical Termination Cap (High Wind)	46DVA-VCH
Vertical Termination Cap (Low Profile)	46DVA-VC
All DuraVent Straight vent pipe sections have a net length 1-1/2" (37mm) less than the nominal dimension; i.e., a 6" (152 mm) Straight pipe section has an effective length of 4-1/2" (115 mm).	

Note: An adapter is not required when using HHT SLP vent pipe on this unit. The twist lock tabs on SLP pipe will not engage the twist lock of the DuraVent collar. A gas tight seal will still be made between the inner and outer pipe sections. Use a minimum of two screws to secure the SLP pipe to the starter collar.

B. Assembling the Stove:

Tools Required

- Phillips screwdriver (stub)
- Utility knife
- Metal drill bit: size 28 (.140"/3.5mm)
- Flat-blade screwdriver
- Power drill
- Reciprocating saw
- 9/16" wrench
- 1/2" Wrench

Parts Bag Contents:

- Three (3) Vent Screws
- Two (2) Switch bracket screws
- Wood handle w/insert lifter (handle for operable door)
- Restrictor Plate
- 4" Starter pipe
- Wireless Remote
- Three (3) Phillips round-head bolts, 1/4"- 20 x 1/2"
- One (1) Tube of Vent Gasket Cement
- Four (4) CS, Hex Hd 3/8-16 x 1 Gr 2-Z
- Four (4) Washer, FI 3/8-Z
- Owner's Installation and Operating Manual

Unpack Stove

Using a 1/2" wrench remove the (4) lag bolts installed through the shipping brackets and into the skid. Using a 7/16" wrench loosen the (4) bolts where the shipping brackets meet the base of the unit. Once loosened, tilt the unit slightly and remove the (2) front bolts, washers and shipping brackets. Use the (4) 1/4-20 x 1" Bolts and 1/4" washers supplied in the manual bag to install the legs where the brackets were once installed. Repeat previous step to install the rear legs.



WARNING

Only the IFT appliance is equipped with a three-prong (grounded) plug for your protection against shock hazard and should be plugged directly into a properly grounded three-prong receptacle. Do not cut or remove the grounding prong from this plug.

C. Venting System Assembly



CAUTION

All HHT Direct Vent Stoves have been tested and approved to ANSI/CSA Standards and will operate safely when installed in accordance with this instruction manual. Read all instructions before starting installation, then follow these instructions carefully to maximize stove performance and safety. Report damaged parts to your dealer.



WARNING

Always maintain minimum clearances around vent systems. Rear/Top Vent Vertical Side wall: Horizontal sections of this vent system require a minimum of 3" (76 mm) clearances to combustibles at the top of the flue and 1" (25 mm) clearance at the sides and bottom until the flue penetrates the outside wall. A minimum 1" clearance all around the flue is acceptable at this point of penetration. If vertical rise is 7 1/2 feet (2.3 m) or higher when top venting, the clearance to combustibles is 1" on all sides of the horizontal run. FOR VERTICAL RUNS ONLY, maintain a 1" (25 mm) minimum clearance to all sides. Do not pack the open air spaces around the stove or flue with insulation or other materials. Any horizontal run must have a 1/4" rise for every one (1) foot of run towards the vent termination. Never run the vent level or down.



WARNING

Failure to follow these instructions may create a possible fire hazard and will void the warranty.



WARNING

Any common venting of this gas appliance with other gas appliances is not allowed.

Important Safety Information

The termination cap **MUST** be vented directly to the outside. The termination kit **MUST NEVER** be connected to a chimney flue(s) servicing a separate solid-fuel burning appliance or any other appliances.

- Termination cap **MUST NOT** be recessed into a wall, Figure 3.1.
- The installation must conform with local codes or in the absence of local codes, with the National Fuel Gas Code, ANSI Z223.1 (in the United States) or with the current installation code CSA B149 (in Canada).

- These models are approved to use HHT direct vent pipe components, HHT termination kits and DuraVent components. No other venting system components may be used.
- Horizontal runs must be supported every 3 feet (914 mm) using wall straps. Vertical runs must be supported every 8 feet (2.4 m) using wall straps. Slip wall straps loosely on to pipe. Attach straps to framing members using nails or screws. Tighten nut/bolt to secure pipe.
- The stove and venting system should be inspected before initial use and at least annually by a qualified field service person. Inspect the external vent cap on a regular basis to make sure that no debris is interfering with the airflow. Inspect entire venting system to ensure proper function.

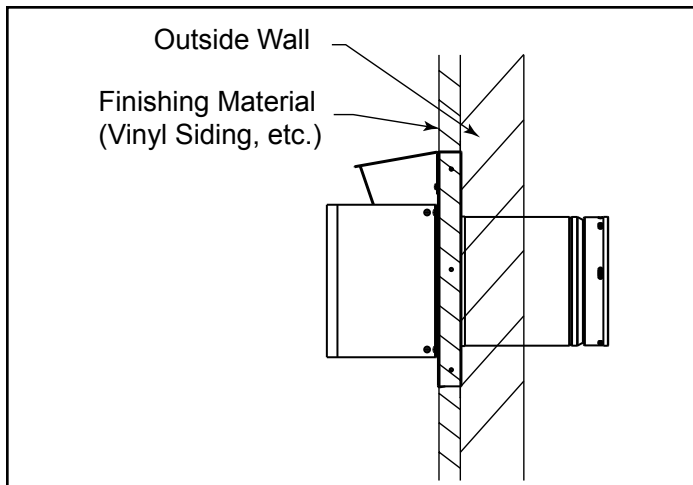

Figure 3.1 - Termination cap on wall

Before You Start

Plan your installation. Set the stove in place and survey how to best vent the unit. Select the appropriate termination kit and vent pipe for the installation. Read these instructions and the stove Owner’s Manual before beginning installation. After vent configuration has been decided, begin attaching pipe to unit.

Items required for installation:

Tools:

- | | |
|----------------------|-------------------------|
| Phillips screwdriver | Hammer |
| Saw and/or saber saw | Level |
| Measuring Tape | Electric drill and bits |
| Pliers | Square |

Building Supplies:

- Framing materials
- Wall finishing materials
- Caulking Material (noncombustible)

⚠ WARNING
Any horizontal run must have a 1/4" rise for every one (1) foot of run towards the vent termination. Never allow the vent pipe to run down. This could cause high temperatures and may present a fire hazard.

⚠ WARNING
Termination cap must be positioned so the embossed arrow is pointed up.

General Information

The Intrepid DV is approved for installation only with the vent components listed under Section A “Venting Requirements & Options”. Follow the vent component instructions exactly.

For U.S. installations: The venting system must conform with local codes and/or the current National Fuel Gas Code, ANSI Z223.1/NFPA 54.

For Canadian installations: The venting system must conform to the current CSA B149.1 installation code.

Assemble Slip Sections

The outer flue of the slip section should slide over the outer flue of the pipe section and into (inner flue) the last pipe section, Figure 3.2.

Slide together to the desired length, making sure that a 1-1/2" outer flue overlap is maintained between the pipe section and slip section.

The pipe and slip section need to be secured by driving two 1/2 in. screws through the overlapping portions of the outer flues using the pilot holes, Figure 3.4.

This will secure the slip section to the desired length and prevent it from separating. The slip section can then be attached to the next pipe section.

If the slip section is too long, the inner and outer flues of the slip section can be cut to the desired length.

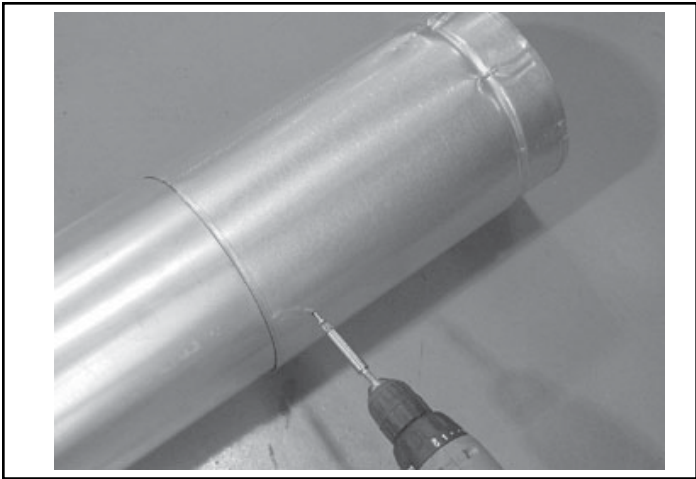



Figure 3.4 - Screws into Slip Section

 WARNING
Risk of Fire/Explosion! DO NOT break seals on slip sections. Use care when removing termination cap from slip pipe. If slip section seals are broken during removal of the termination cap, vent may leak.

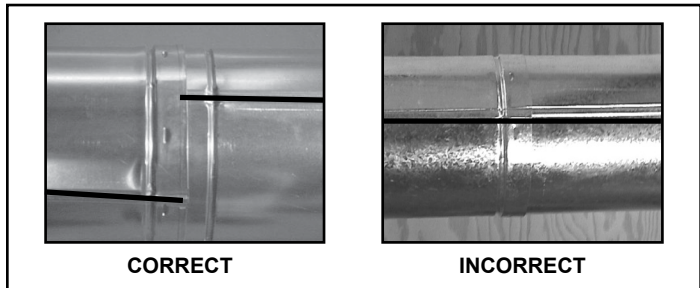

Figure 3.2 - Make sure the seams are not aligned to prevent unintentional disconnection.

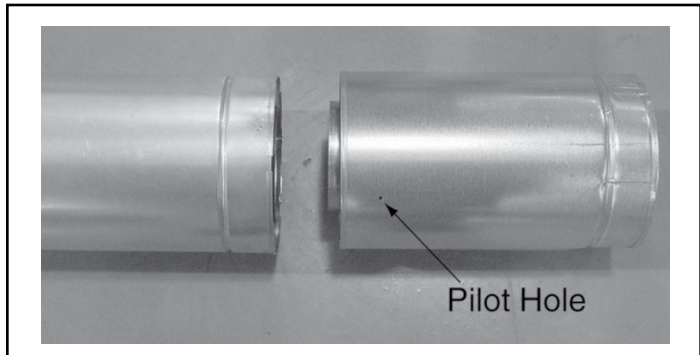

Figure 3.3 - Slip Section Pilot Holes

Secure the Vent Sections

Vertical sections of SLP pipe must be supported every 8 feet.

The SLP firestop includes tabs that may be used to secure vertical sections.

The vent support or plumber's strap (spaced 120° apart) may be used to secure the vertical sections of pipe, Figure 3.5.

Horizontal sections of vent must be supported every 5 feet with a vent support or plumber's strap, Figure 3.6.

 WARNING
Risk of Fire/Explosion/Asphyxiation! Improper support may allow vent to sag and separate. Use vent run supports and connect vent sections per installation instructions. DO NOT allow vent to sag below connection point to appliance.

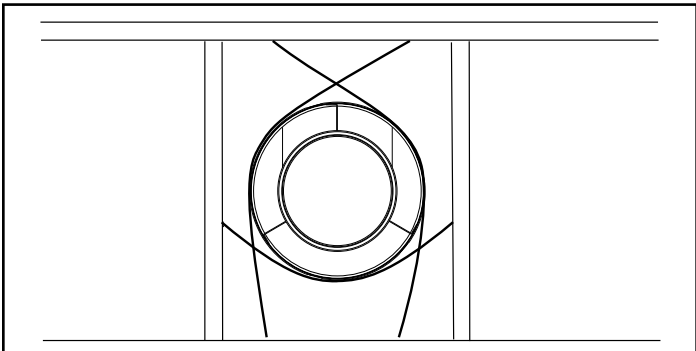

Figure 3.5 - Securing Vertical Pipe Sections

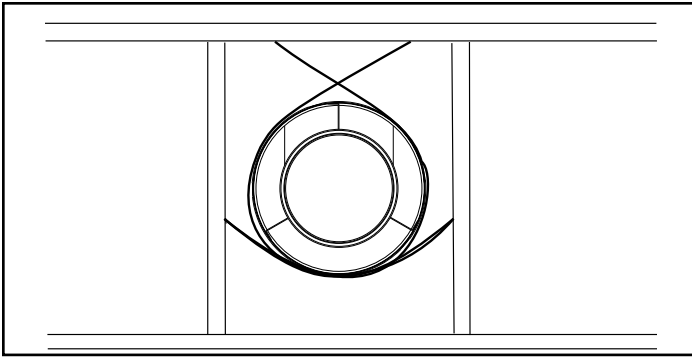

Figure 3.6 - Securing Horizontal Pipe Sections

Disassemble Vent Sections:

To disassemble any two pieces of pipe, rotate either section, Figure 3.7, so that the seams on both pipe sections are aligned, Figure 3.8. They can then be carefully pulled apart.

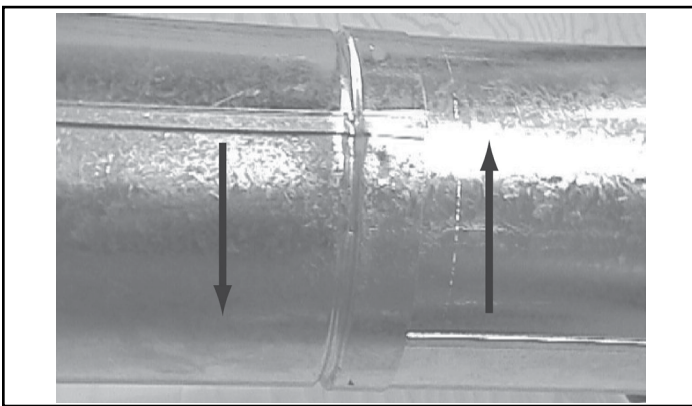

Figure 3.7 - Rotate Seams for Disassembly

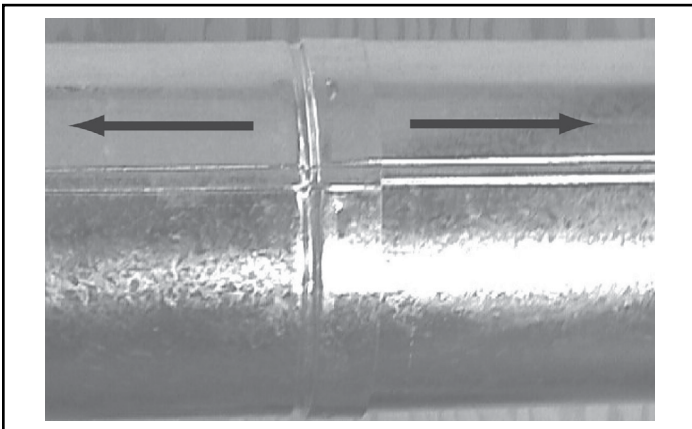



Figure 3.8 - Align and Disassemble Vent Sections

Horizontal Termination Cap:

 WARNING
<p>Risk of Fire! The telescoping flue section of the termination cap MUST be used when connecting vent.</p> <ul style="list-style-type: none"> • 1-1/2" (38 mm) minimum overlap of vent and telescoping flue section is required. <p>Failure to maintain overlap may cause overheating and fire.</p>

Note: For horizontal vent runs through a combustible wall and framing dimensions, refer to appliance installation manual.

Install the Horizontal Termination Cap

Attach slip section of cap to last vent section. Maintain 1-1/2" overlap between slip and vent sections.

Note: For installations using black pipe, slide the decorative wall thimble over the last vent pipe before connecting the termination to the pipe. When this connection has been made, slide the wall thimble up to the interior wall surface and attach with screws provided.

Secure termination cap to exterior wall using provided holes and fasteners.

Vent termination must not be recessed in the wall. Siding may be brought to the edge of the cap base.

 CAUTION
<p>Risk of Burns! Local codes may require installation of a termination guard to prevent anything or anyone from touching the hot cap.</p>

Flash and seal as appropriate for siding material at outside edges of cap.

When installing a horizontal termination cap, follow the cap location guidelines as prescribed by current ANSI Z223.1 and CAN/CGA-B149 installation codes.

Divert Roof Run-off

HHT recommends, where excessive water run-off is possible, use of one of the two options shown in Figure 3.9 to prevent water running off the roof and onto/into the horizontal termination cap.

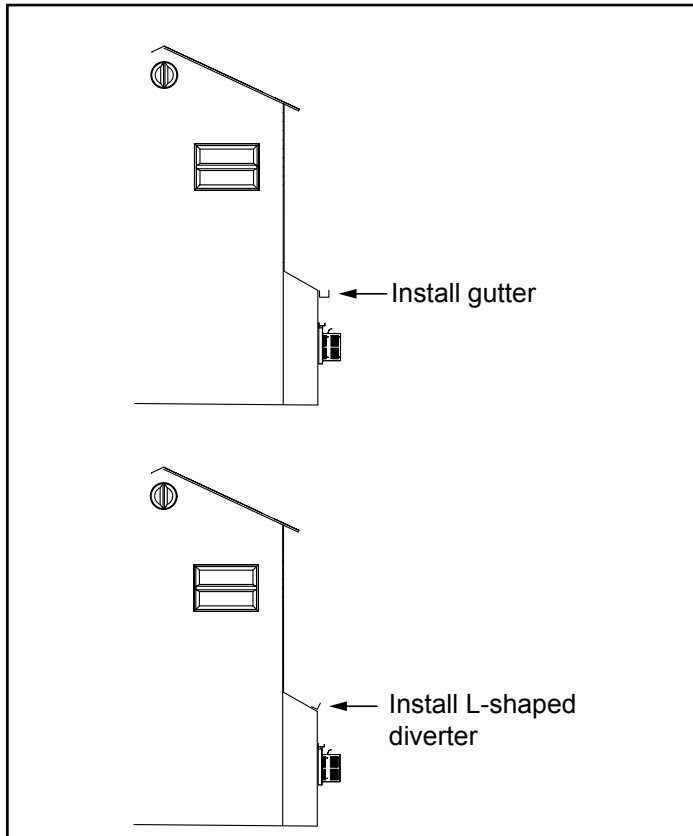

Figure 3.9 - Locate Vent Opening on Wall

Vertical Side Wall Installation:

NOTE: Refer to Figures 2.8 thru 2.10 for restrictor plate adjustments for vertical vent runs.

1. Locate vent opening on the wall. It may be necessary to first position the stove and measure to obtain hole location. Depending on whether the wall is combustible or noncombustible, cut opening to size, Figure 3.10 (For combustible walls first frame in opening.)
 Combustible Walls: Cut a 10" H x 10" W (254 x 254 mm) hole through the exterior wall and frame as shown, Figure 3.10.
 Noncombustible Walls: Hole opening must be 7-1/2" (191 mm) in diameter.

NOTE: When using flex vent, the opening will have to be measured according to the 1/2" (13 mm) rise in 12" (305 mm) vent run.

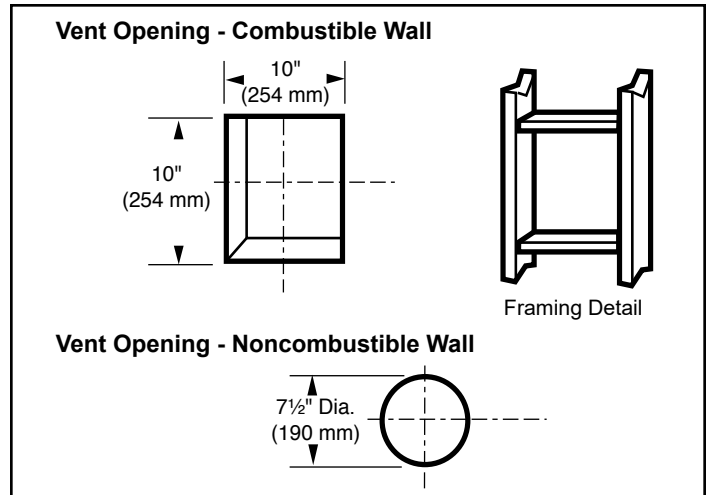

Figure 3.10 - Locate vent opening. **NOTE: Zero clearance sleeve is required for combustible wall installations.**

2. Secure firestop to the inside frame, center in the 10" x 10" vent opening.
3. Place stove into position. Measure the vertical height (X) required from the base of the flue collars to the center of the wall opening, Figure 3.11.

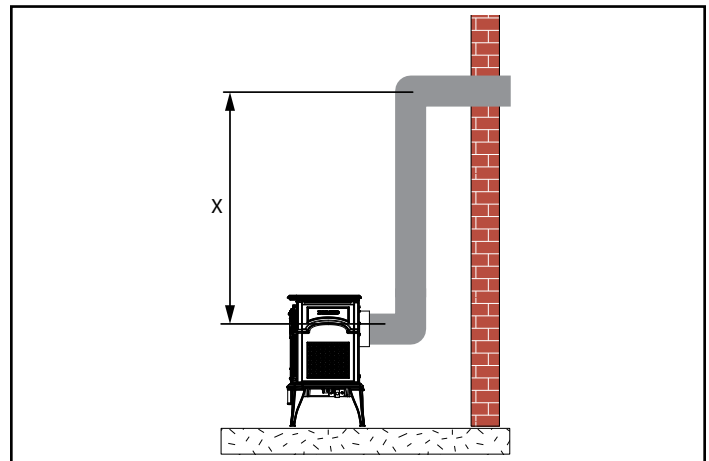

Figure 3.11 - Vertical Height Requirements

4. Using appropriate length of pipe section(s) attach to stove by twisting collar.
5. Measure the horizontal length requirement including a 2" (51 mm) overlap, i.e. from the elbow to the outside wall face plus 2" (51 mm) (or the distance required if installing a second 90° elbow), Figure 3.12.

NOTE: Always install vertical side wall horizontal venting with a 1/4" rise for every 12" of run.

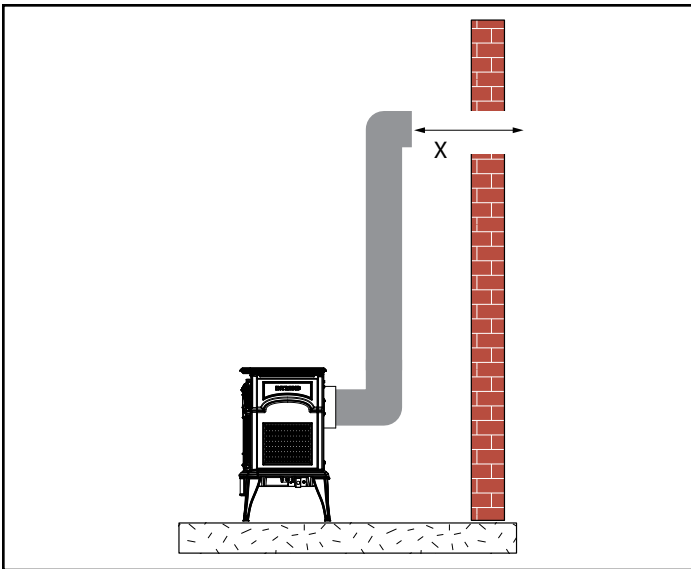

Figure 3.12 - Horizontal Length Requirement

6. Use appropriate length of pipe sections – telescopic or fixed – and install. The sections which go through the wall are packaged with the starter kit, and can be cut to suit if necessary.
7. Guide the vent terminations 4" and 6-5/8" collars into their respective vent pipes. Double check that the vent pipes overlap the collars by 2" (51 mm). Secure the termination to the wall with screws provided and caulk around the wall plate to weatherproof. As an alternative to screwing the termination directly to the wall, you may also use expanding plugs or an approved exterior construction adhesive.

NOTE: Support horizontal pipes every 5' (152 cm) with metal pipe straps.

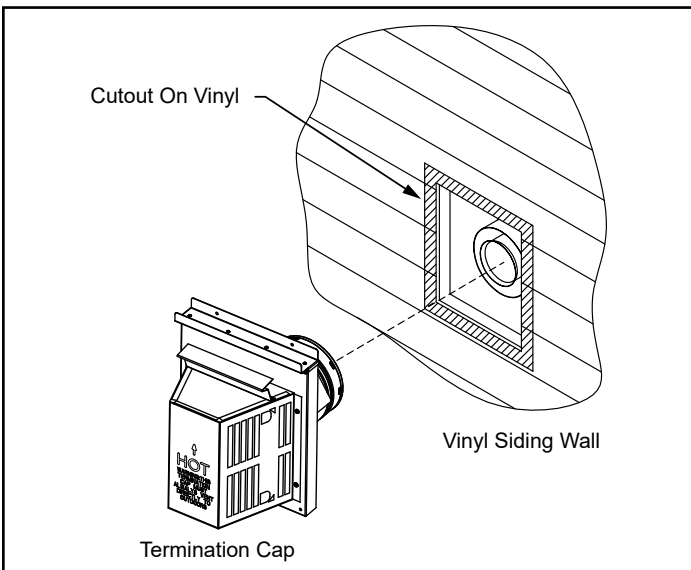

Figure 3.13 - Horizontal Termination Cap on a Vinyl Siding Wall

Vent Termination Below Grade:

Install Snorkel Kit #SLP-SNORK when it is not possible to meet the required vent termination clearances of 12" (305 mm) above grade level. The snorkel kit will allow installation depth of down to 7" (178 mm) below grade level. The seven inches is measured from the center of the horizontal vent pipe as it penetrates the wall. **If the venting system is installed below grade, a window well must be installed with adequate and proper drainage.**

NOTE: Be sure to maintain side wall clearances and vent run restrictions. Refer to Figures 2.3 thru 2.6.

1. Establish the vent hole through the wall.
2. Remove soil to a depth of approximately 16" (406 mm) below the base of the snorkel. Install a window well (not supplied). Refill the hole with 12" (305 mm) of coarse gravel and maintain a clearance of at least 4" (102 mm) below the snorkel, Figure 3.14.
3. Install the vent system as described in Figures 3.2 thru 3.14.
4. Be sure to make a watertight joint around the vent pipe joint at the inside and outside wall joints.
5. Apply high temperature sealant around the inner and outer snorkel collars. Join the pipes and fasten the snorkel termination to the wall with the screws provided.
6. Level the soil to maintain a 4" clearance below the snorkel.
7. If the foundation is recessed, use extension brackets (not supplied) to fasten the lower portion of the snorkel. Fasten the brackets to the wall first, and then fasten to the snorkel with self-tapping #8 x 1/2" sheet metal screws. Extend the vent pipes out as far as the protruding wall face, Figure 3.14.

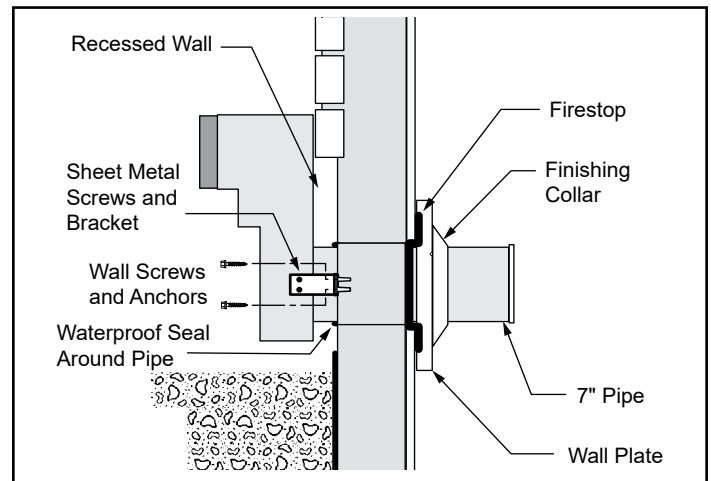

Figure 3.14 - Use extension brackets to mount snorkel against recessed wall.

Vertical Through-The-Roof Application/Installation:

Note: Refer to Figures 2.8 thru 2.10 for restrictor plate adjustments for vertical vent runs.

This gas stove has been approved for:

- Vertical installations up to 40 feet (12 m) in height. Up to a 10 feet (3 m) horizontal vent run can be installed within the vent system using a maximum of two 90° elbows, Figure 3.15.
- Up to two 45° elbows may be used within the horizontal run. For each 45° elbow used on the horizontal plane, the maximum horizontal length must be reduced by 18" (450 mm).

Example: Maximum horizontal length:

- No elbows = 10' (3 m)
- 1 x 45° elbow = 8.5' (2.6 m)
- 2 x 45° elbows = 7' (2.1 m)

- A minimum of an 8 feet (2.5 m) vertical rise is required, Figure 3.15.
- Two sets of 45° elbow offsets may be used within the vertical sections. From 0 to a maximum of 8 feet (2.5 m) of vent pipe can be used between elbows, Figure 3.16.
- SLP-HVS supports offsets. This application will require that you first determine the roof pitch and use the appropriate starter kit. (Refer to Venting Components list.)
- The maximum angular variation allowed in the system is 270°, Figure 3.16.
- For the minimum height of the vent above the highest point of penetration through the roof, Figure 3.16.

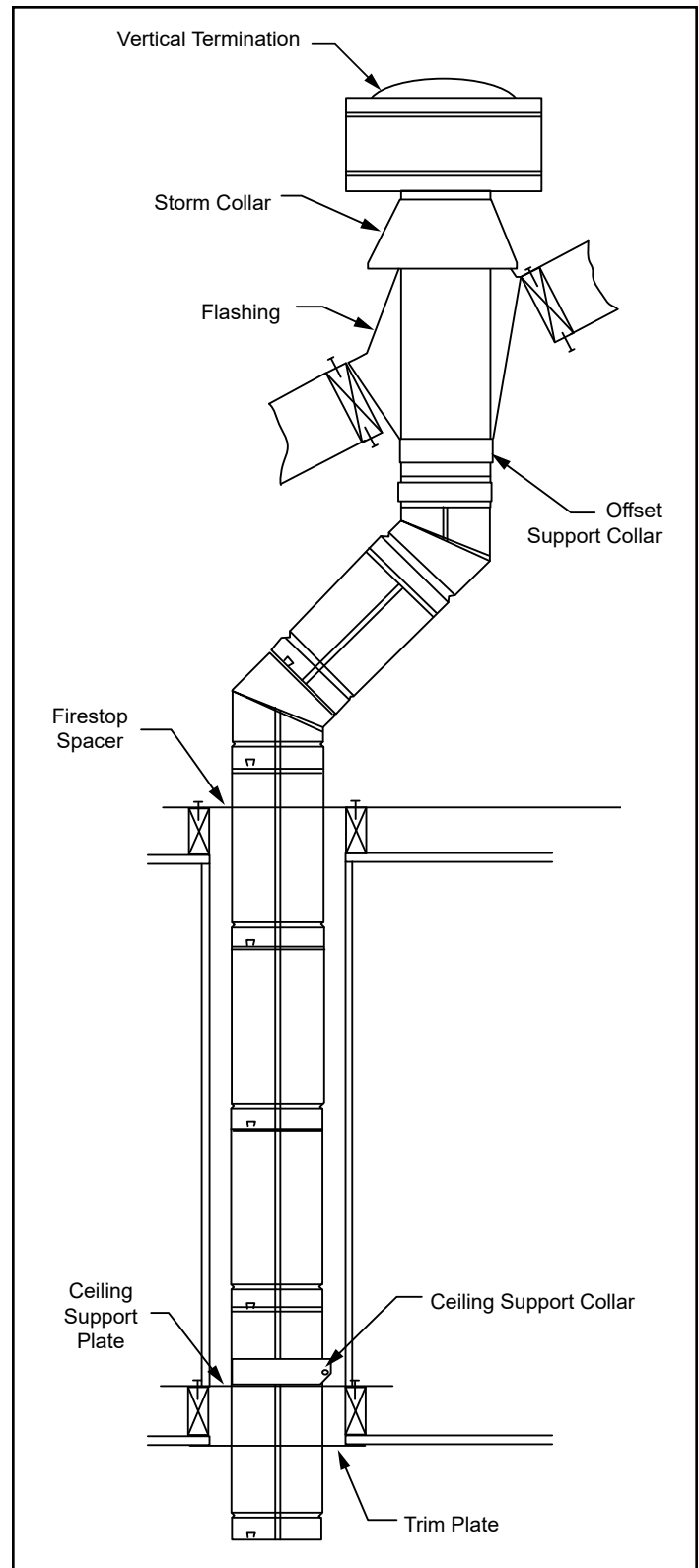
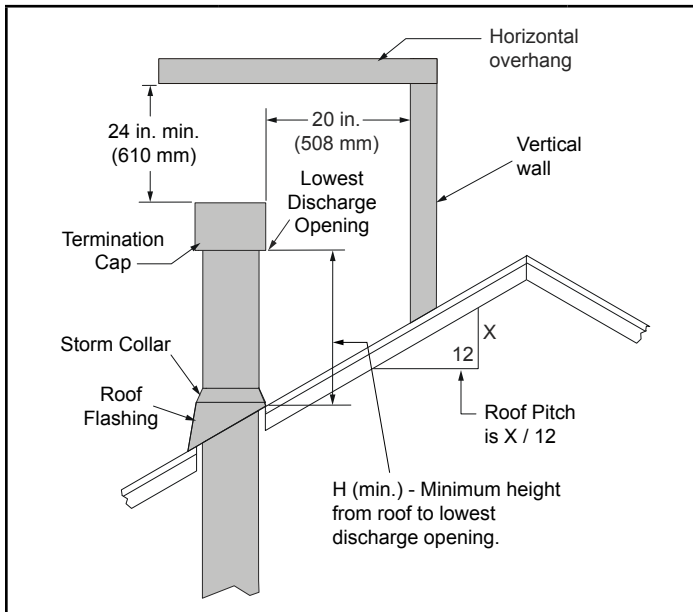

Figure 3.16 - Typical Vertical Venting Configuration



Roof Pitch	H (Min.) Ft.	Roof Pitch	H (Min.) Ft.
Flat to 6/12	1.0*	Over 11/12 to 12/12	4.0
Over 6/12 to 7/12	1.25*	Over 12/12 to 14/12	5.0
Over 7/12 to 8/12	1.5*	Over 14/12 to 16/12	6.0
Over 8/12 to 9/12	2.0*	Over 16/12 to 18/12	7.0
Over 9/12 to 10/12	2.5	Over 18/12 to 20/12	7.5
Over 10/12 to 11/12	3.25	Over 20/12 to 21/12	8.0

* 3 Feet. Minimum in Snow Regions

Figure 3.16 - Minimum Height from Roof to Lowest Discharge Opening

For U.S. installations: The venting system must conform with local codes and/or the current National Fuel Gas Code, ANSI Z223.1/NFPA 54

For Canadian installations: The venting system must conform to the current CSA B149.1 installation code.

Options

HHT offers a complete line of component parts for both horizontal and vertical installation. Many items are offered in decorative black as well as galvanized finish. The galvanized pipe and fittings may be used for concealed locations such as attics, or spaces where corrosion is a factor, such as above the roofline. Decorative black painted sections are recommended for use on visible interior runs. Snorkel Terminations are available for applications which may require vertical rise on the building exterior.

Planning Your Installation

There are two basic types of installations:

- Horizontal Termination, Figures 3.17 & 3.18.
- Vertical Terminations, Figure 3.19

When planning your installation, it will be necessary to select the proper length of vent pipe for your particular requirement. For horizontal installations, check these instructions to determine the minimum clearance from the rear of the appliance to the wall. It is also important to note the wall thickness. Select the amount of vertical rise desired or required, for “vertical-to-horizontal” installations (verify that it is within the minimum and maximum limits. To determine the length of vent pipe required for vertical installations, measure the distance from the appliance flue outlet to the ceiling, the ceiling thickness, the vertical rise in an attic or second story, and allow for sufficient vent height above the roofline. For multi-story applications, firestops are required at each floor/ceiling level. If an offset is needed in the attic, additional pipe and elbows will be required.

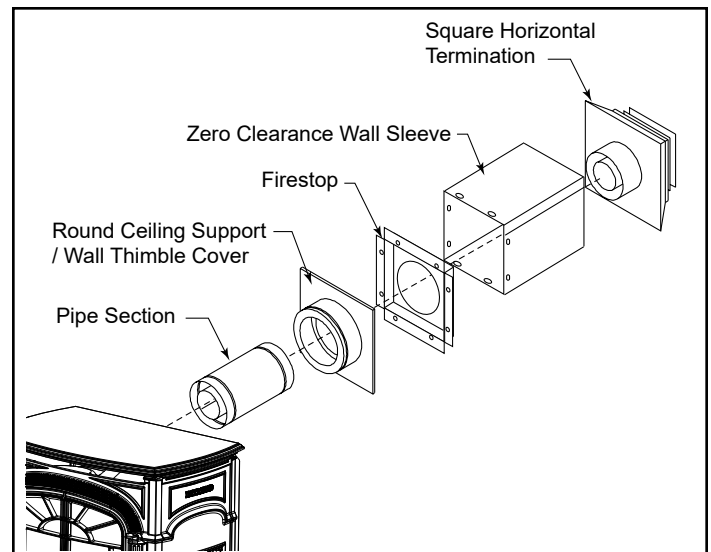

Figure 3.17

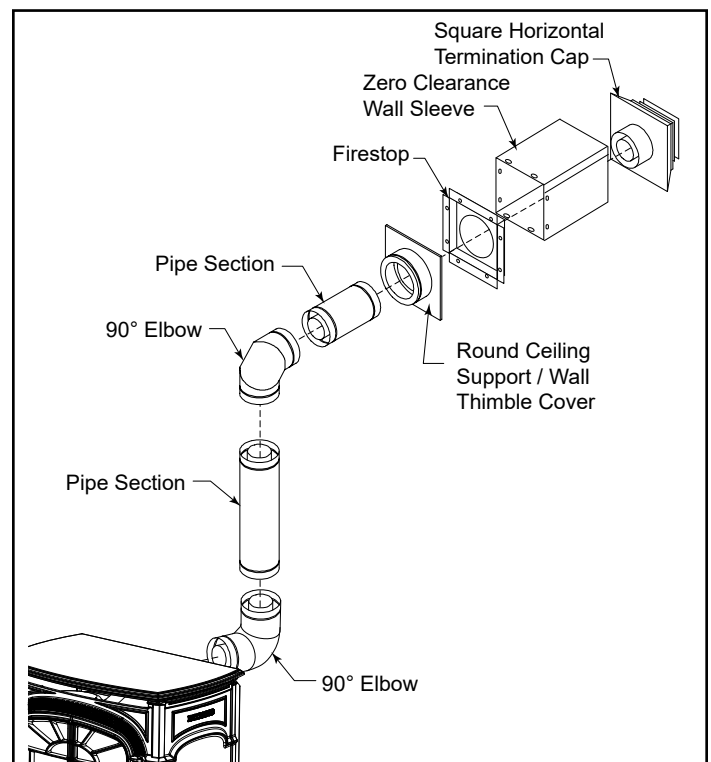

Figure 3.18

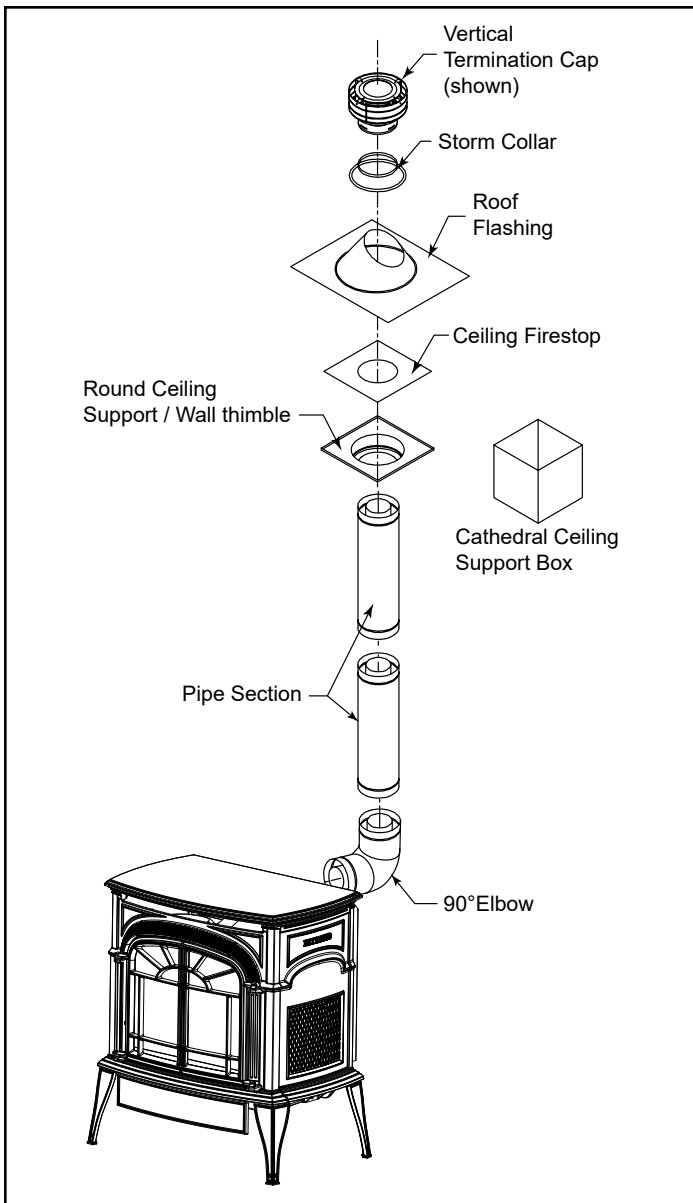

Figure 3.19

Rear Vent

Use components listed under "**Approved Vent System Components**" under 'Basic Straight through-the-Wall Installation' for an installation where the heater is parallel to the wall and the vent system extends straight back through that wall.

1. Locate the vent opening on the wall. Refer to Figures 3.20 & 3.21 to determine the top of the opening centerline. It may be necessary to first position the stove and measure to find the hole location. Depending on whether the wall is made of combustible materials, cut the opening to the size shown in Figure 3.20. Combustible wall openings must be framed as shown in Figure 3.20.
2. Measure the wall thickness and cut the zero clearance sleeve sections to proper length (MAXIMUM 12"). Assemble the sleeve with the #8 sheet metal screws supplied. Attach the firestop plate to the sleeve end with the holes, Figure 3.22. **NOTE:** The zero clearance sleeve is required in combustible walls only.

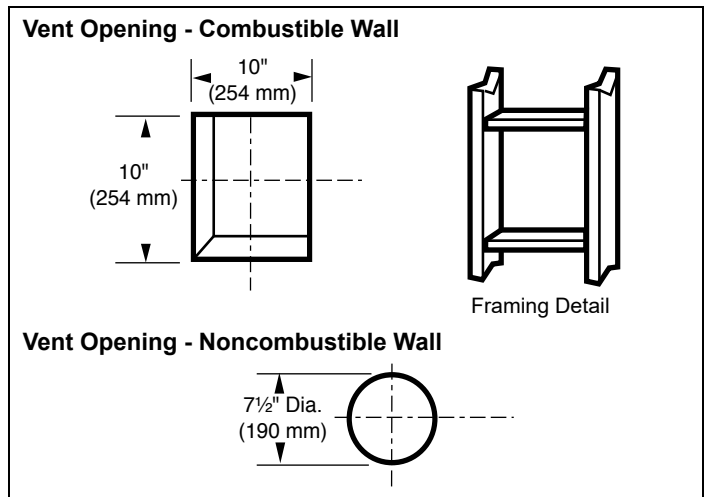

Figure 3.20 - Locate vent opening. **NOTE: Zero clearance sleeve is required for combustible wall installations.**

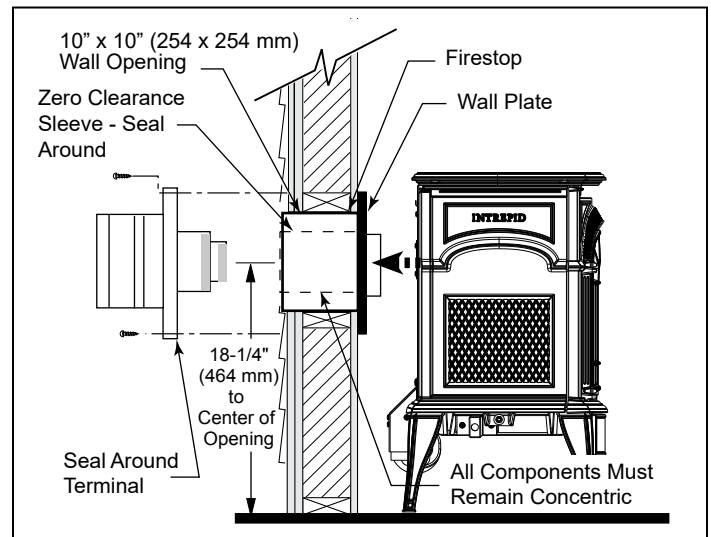

Figure 3.21 - Intrepid minimum horizontal rear vent installation.

3. Install the Wall Firestop/Sleeve assembly into the wall cutout and fasten the firestop to the wall cutout framing members, Figure 3.22.

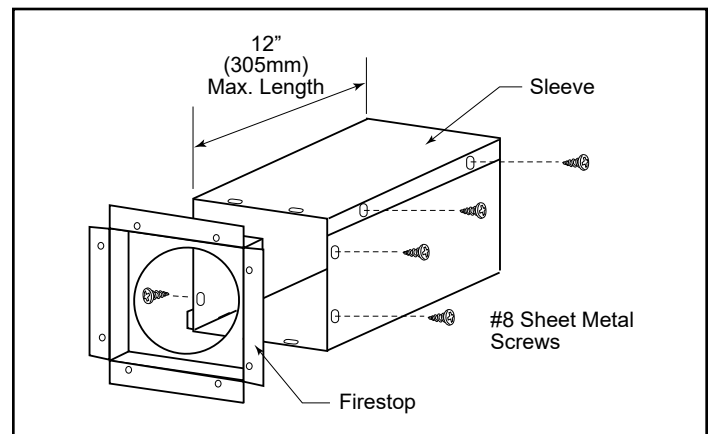

Figure 3.22 - Assemble the wall sleeve and firestop.

- Slip the wall cover over the interior end of the horizontal pipe and install into the zero clearance sleeve. Seal the joint inside the wall plate if needed to keep cold air from being drawn into the home.
- Install the vent terminal, Figure 3.21. Guide the inner and outer vent termination collars into the adjacent pipes. Double check that the vent pipes overlap the collars by 2". Fasten the termination to the outside wall with the screws provided, and caulk the joint with weatherproof sealant.
- Use wall straps to support vertical pipe runs at 8' (2.4 m) intervals.

Horizontal Installation

Step 1 - Set the gas appliance in its desired location. Check to determine if wall studs or roof rafters are in the way once the venting system is attached. If this is the case, you may want to adjust the location of the appliance.

Step 2 - DirectVent Pro pipe, SLP pipe and fittings are designed with special twist-lock connections. To connect the venting system to the appliance flue outlet, a twist-lock appliance adaptor is built into the appliance at the factory. Assemble the desired combinations of black pipe sections and elbows to the appliance adaptor with pipe seams oriented towards the wall or floor, as much out of view as possible, Figure 3.23.

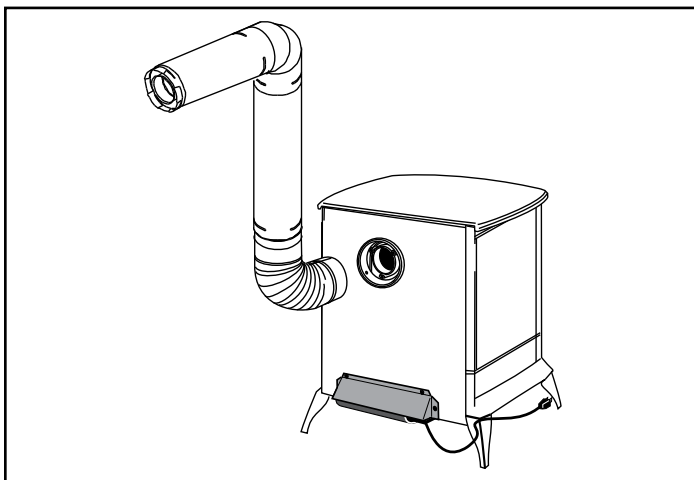

Figure 3.23

NOTES:

- Twist-lock procedure: Line up locking lugs on male and female ends of pipe sections. Insert the male end of pipe into the female end until the locking lugs are covered. Twist the female end clockwise an eighth of a turn to lock sections together, Figure 3.24. Screws are not required to secure the joint, but are acceptable provided they do not penetrate the inner wall of the vent pipe.

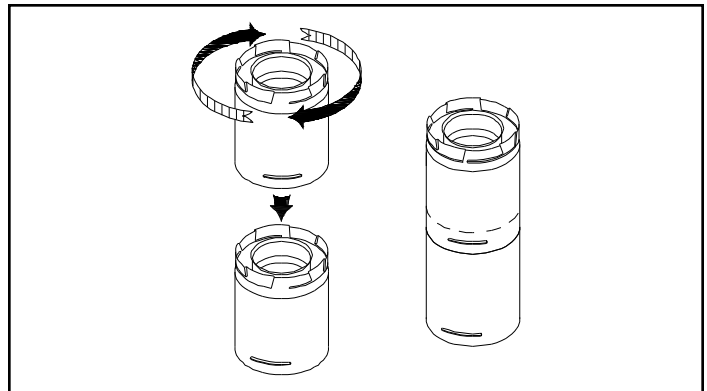

Figure 3.24

- Horizontal vent runs of vent pipe must be supported to prevent any downward sags. Horizontal pipe sections should be supported at least every 5' (1.5 m). Wall straps can be used for this purpose. Alternatively, plumbers tape or other suitable noncombustible material can be used to support the vent pipe.

- DirectVent Pro and SLP venting requires no sealant.

Step 3 - With the appliance adaptor and pipe section attached, slide the stove into its correct location. Mark the wall for a square hole that measures 10" x 10" (254 x 254 mm). The centerline of the pipe should line up with the center of the square hole, Figure 3.25. Cut and frame the square hole in the exterior wall where the vent will be terminated. If the wall being penetrated is constructed of noncombustible material only, i.e. masonry block, brick or concrete only, a hole with zero clearance is acceptable.

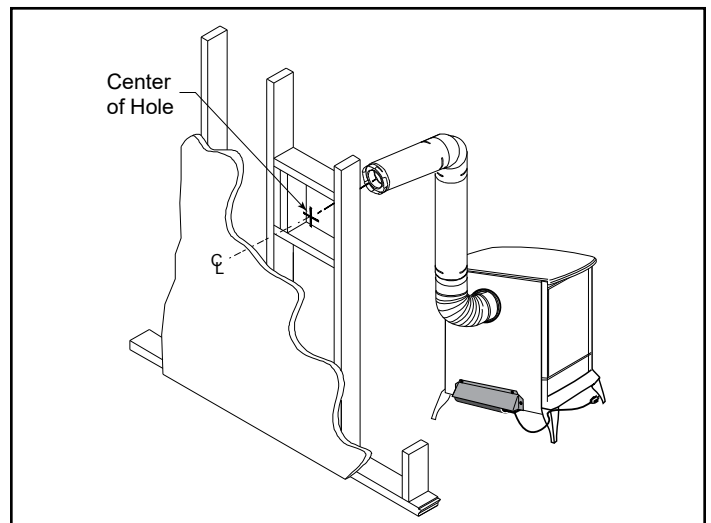

Figure 3.25

NOTES:

- The horizontal run of venting must be level, or have a 1/4" (6 mm) rise for every 1' (305 mm) of run toward the termination. Never allow the vent to run downward. A downward slope can trap heat and become a possible fire hazard.

- The location of the horizontal vent termination on an exterior wall must meet all local and national building codes, and must not be easily blocked or obstructed. Refer to "**Vent Termination Clearances**" for proper Termination Clearances.

For installations requiring a vertical rise on the exterior of the building, 14" (356 mm) and 36" (914 mm) tall snorkel terminations are available, Figure 3.26. Follow the same installation procedures as used for standard horizontal terminations. If the snorkel termination must be installed below grade level, (i.e. basement application), proper drainage must be provided to prevent water from entering the snorkel termination, Figure 3.27. Do not attempt to enclose the snorkel within the wall or any other type of enclosure.

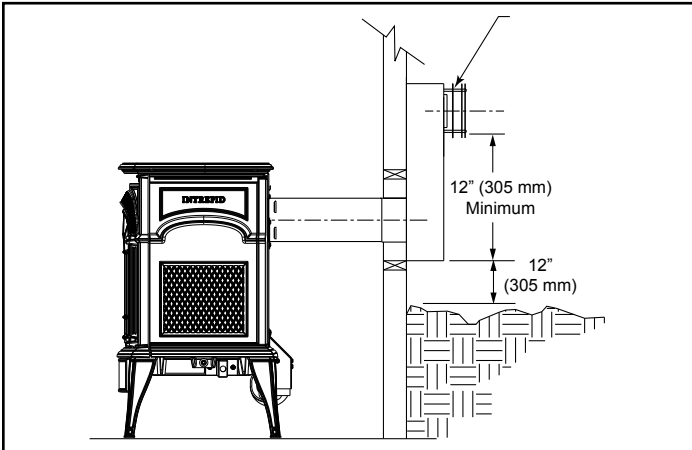

Figure 3.26

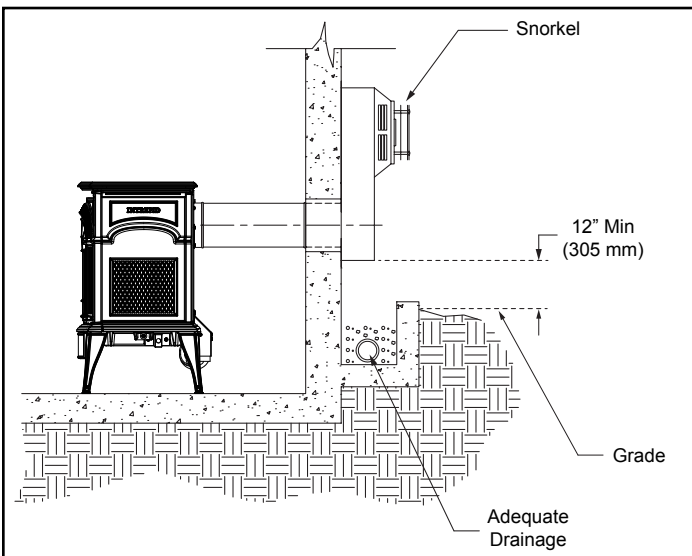

Figure 3.27

Step 4 - Position the horizontal termination cap in the center of the square framed hole, and attach to the exterior wall with the four (4) wood screws provided. Before attaching the vent termination cap to the exterior wall, run a bead of non-hardening silicone sealant around the outside edges to make a seal between the cap and the wall. The arrow on the vent cap should be pointing up. Ensure proper clearances to combustible materials are maintained, Figure 3.28.

NOTES:

- The four (4) wood screws provided should be replaced with appropriate fasteners for use on brick, block, concrete or other types of sidings.
- For buildings with vinyl siding or stucco, another component must be used between the horizontal termination cap and the wall surface. The vinyl siding standoff

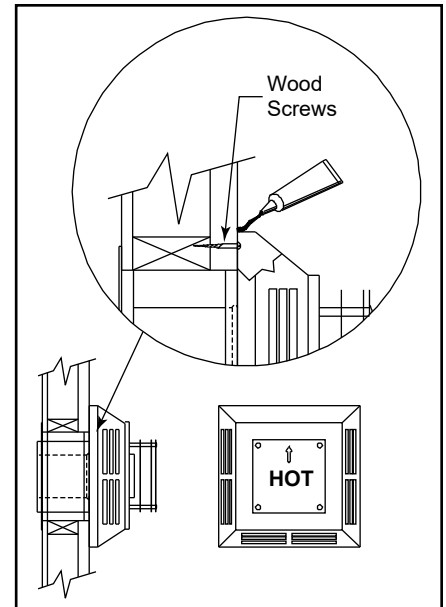

Figure 3.28

prevents excessive heat from possibly melting the vinyl siding material. Vinyl siding standoffs are not required with snorkels. For vinyl wall installations a 4-piece vinyl siding standoff should be assembled and installed between the horizontal termination cap and the exterior wall, Figure 3.29. The vinyl should be cut away to the outer edges of the assembled standoff.

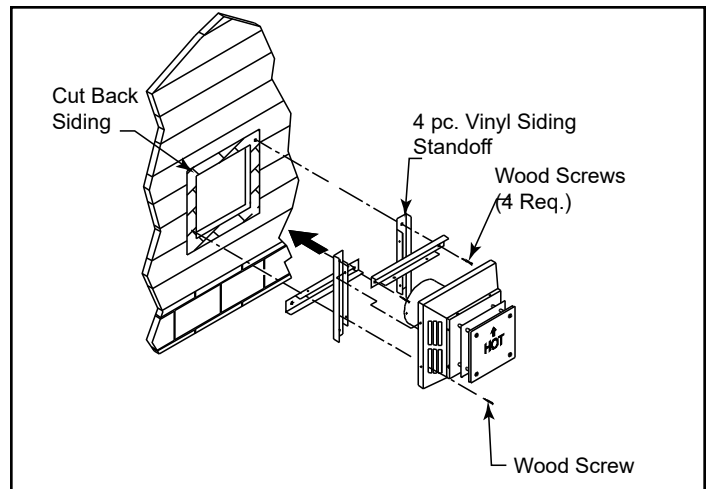

Figure 3.29

IMPORTANT: You must attach the four (4) pieces of the new vinyl siding standoff to the horizontal termination cap in specific order to ensure a weather tight fit. Loosely assemble the four parts, in order, around the base of the horizontal termination cap. Place the first of four pieces along the upper edge of the cap, then using two (2) screws per side, secure each piece to the pre-drilled holes along both sides of the cap, finally, attach the final piece to the bottom edge of the cap. Tighten all screws and mount cap, with all four (4) pieces attached, directly onto the wall with the four (4) 2-1/2" (64 mm) screws provided, Figure 3.29.

3. When penetrating through stucco wall, install the counter flashing. The counter flashing allows stucco, or other materials, to be finished directly to the sides of the termination cap. First attach the counter flashing to the base of the horizontal termination cap with the small screws provided, then mount entire assembly onto the wall with the four (4) 2-1/2" (64 mm) wood screws provided.

Step 4 - Before connecting your horizontal pipe sections to the horizontal termination cap, slide the wall thimble cover over the pipe section nearest the interior side of wall, Figure 3.14.

Step 5 - Slide the appliance and vent assembly towards the wall, carefully inserting the pipe section into the cap assembly. It is important the pipe section extends into the back of the termination cap with a minimum overlap of 1-1/4" (32 mm). Use the two (2) sheet metal screws provided to secure the pipe section to the back of the termination cap. The wall thimble cover will cover the screw heads, Figure 3.30.

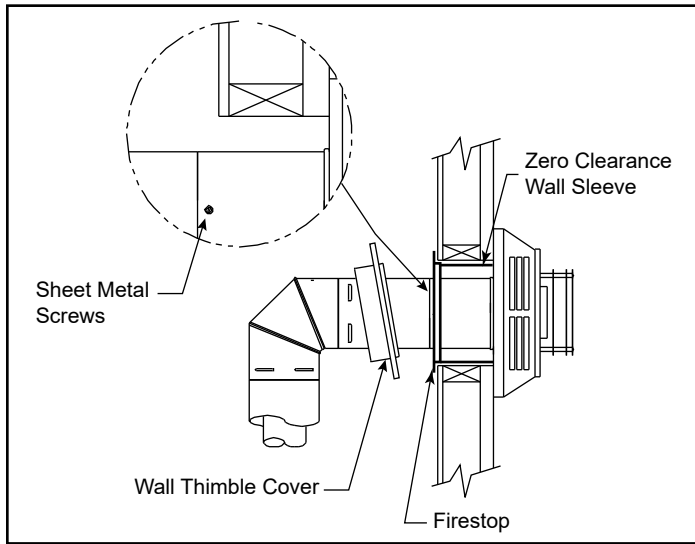

Figure 3.30

Step 6 - Slide the wall thimble cover up to the wall surface and attach to the wall with screws provided, Figure 3.31. Apply optional decorative brass trim to wall thimble cover if desired.

Vertical Installation

Step 1 - Check these installation instructions for required clearances (air spaces) to combustibles when passing through ceilings, walls, roofs, enclosures, attic rafters or other nearby combustible surfaces. Do not pack air spaces with insulation. Check these instructions for maximum vertical rise of the venting system and any maximum horizontal offset limitations.

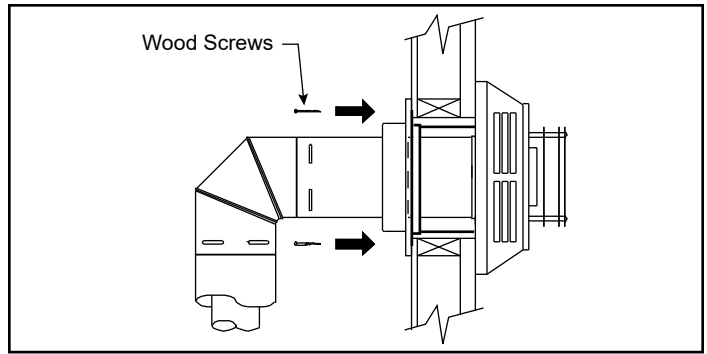

Figure 3.31

Step 2 - Set the gas appliance in the desired location. Drop a plumb bob from the ceiling to the position of the appliance flue exit, and mark the location where the vent will penetrate the ceiling. Drill a small hole at this point. Next, drop a plumb bob from the roof to the hole previously drilled in the ceiling, and mark the spot where the vent will penetrate the roof, Figure 3.32. Determine if ceiling joists, roof rafters, framing or other materials will obstruct the venting system. You may wish to relocate the appliance or to offset, to avoid cutting load-bearing members.

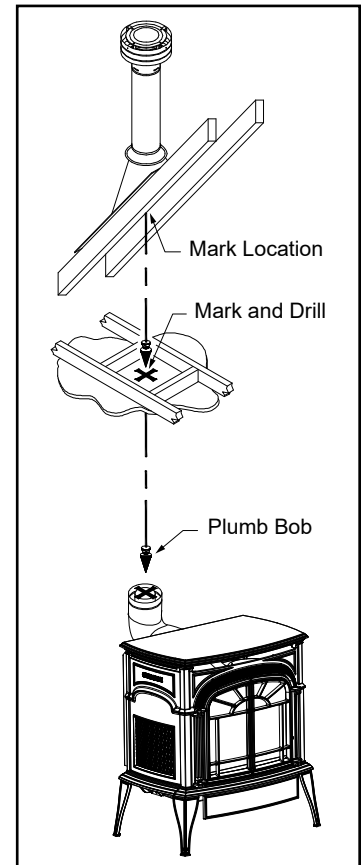

Figure 3.32

Step 3 - To install the round ceiling support/wall thimble cover in a flat ceiling, cut a 10" x 10" (254 x 254 mm) square hole in the ceiling (unless otherwise specified) centered on the hole drilled in Step 2. Frame the hole as shown in Figure 3.33.

Step 4 - Assemble the desired pipe sections and elbows necessary to reach from the appliance adapter up through the round ceiling cover or support box. Ensure that all pipe and elbow connections are in their fully twist-locked position.

Step 5 - Cut a hole in the roof centered on the small drill hole placed in the roof in Step 2. The opening should be of sufficient size to meet the minimum requirements for clearance to combustibles, as specified.

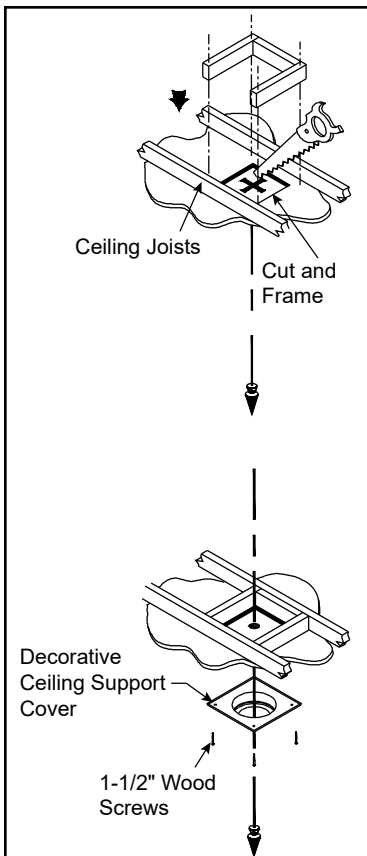

Figure 3.33

Continue to assemble pipe sections and elbows as necessary to reach up through the roofline. Galvanized pipe and elbows may be utilized in the attic, as well as above the roofline. The galvanized finish is desirable above the roofline, due to higher corrosion resistance.

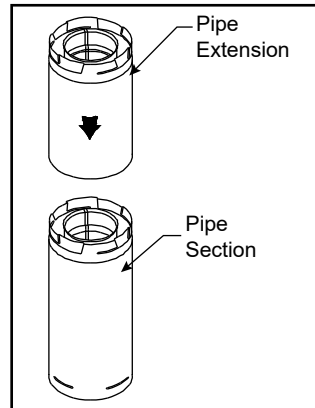

Figure 3.34

NOTES:

1. If exact lengths or distances must be met between elbow offsets or elsewhere, use the pipe extensions to adjust onto standard pipe sections, Figure 3.34.
2. If an offset is necessary in the attic to avoid obstructions, it is important to support the vent pipe in order to avoid excessive stress on the elbows. Wall straps or plumber tape may be used for this purpose, Figure 3.35
3. Wherever possible, use 45° elbows instead of 90° elbows. The 45° elbow offers less restriction to the flow of flue gases and intake air.

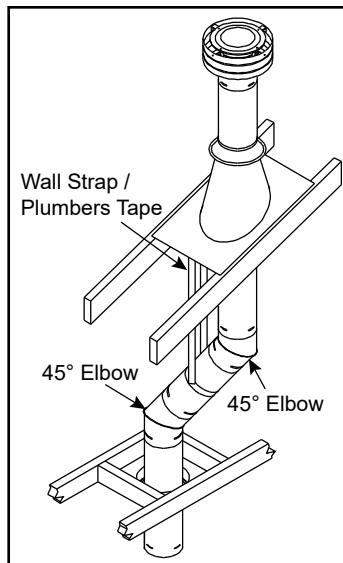

Figure 3.35

Step 6 - Slip the roof flashing over the pipe section(s) protruding through the roof. Use a non-hardening sealant between the roof flashing and the roofing to prevent water leakage. Secure the base of the roof flashing to the roof with roofing nails.

Ensure the roofing material overlaps the top edge of the roof flashing, Figure 3.37. Verify that you have at least the minimum clearances to combustibles at the roofline and in the attic.

Step 7 - Continue to add pipe sections until the height of the system (before adding the cap) meets the minimum building codes requirements as described in Table 2, Figure 3.36. Note that for steep roof pitches, the vent height must be increased. In high wind conditions, nearby trees, adjoining rooflines, steep pitched roofs and other similar factors can result in poor draft, or down drafting.

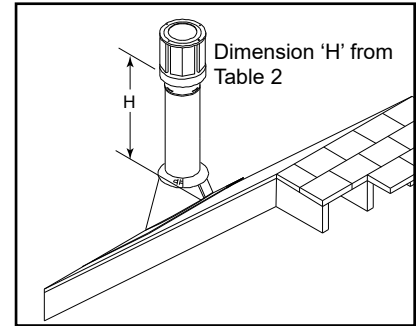

Figure 3.36

Roof Pitch	Minimum Height
Flat 7/12	1' (914 mm)
Over 7/12 to 8/12	1' 6" (457 mm)
Over 8/12 to 9/12	2' (610 mm)
Over 9/12 to 10/12	2' 6" (762 mm)
Over 10/12 to 11/12	3' 3" (990 mm)
Over 11/12 to 12/12	4' (1.2 m)
Over 12/12 to 14/12	5' (1.5 m)
Over 14/12 to 16/12	6' (1.8 m)
Over 16/12 to 18/12	7' (2.1 m)
Over 18/12 to 20/12	7' 3" (2.3 m)
Over 20/12 to 21/12	8' (2.4 m)

In these cases, increasing the vent height or switching to the high wind termination cap may help to solve the problem.

Step 8 - Slip the storm collar over the pipe section, and push it down to the top of the roof flashing, Figure 3.37. Use non-hardening sealant between the storm collar and the pipe section

Step 9 - Holding the bottom of the termination cap only, twist lock the cap onto the last pipe section protruding above the roofline.

NOTES:

1. For multi-story vertical installations, a ceiling firestop is required at the second floor, and any subsequent floors, Figure 3.22. Cut and frame a 9" x 9" (229 mm x 229 mm) square opening for installation of the ceiling firestop.
2. If vent passes through any occupied areas above the first floor, including closets and storage spaces, it must be enclosed. The enclosure may be framed and covered with sheet rock with standard construction materials, but required clearances to combustibles must be maintained.

Consult these installation instructions for the minimum allowable clearances between the outside of the vent pipe and the combustible surfaces of the enclosure. Do not fill required air spaces with insulation.

3. If venting system passes through an attic space an attic insulation shield must be installed to prevent contact between pipe sections and the insulation. Nail the base to floor of attic and adjust shield for appropriate insulation level, then attach the collar at the top of assembly, Figure 3.38. For vaulted

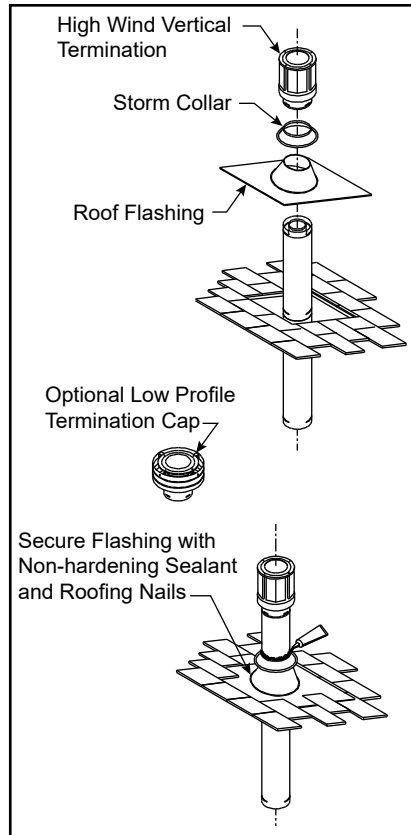

Figure 3.37

ceilings, the attic insulation shield cannot be installed. To prevent building insulation and other debris from entering the support box or contacting the pipe, a chase enclosure can be constructed around the support box. Ensure proper clearance to combustibles are maintained.

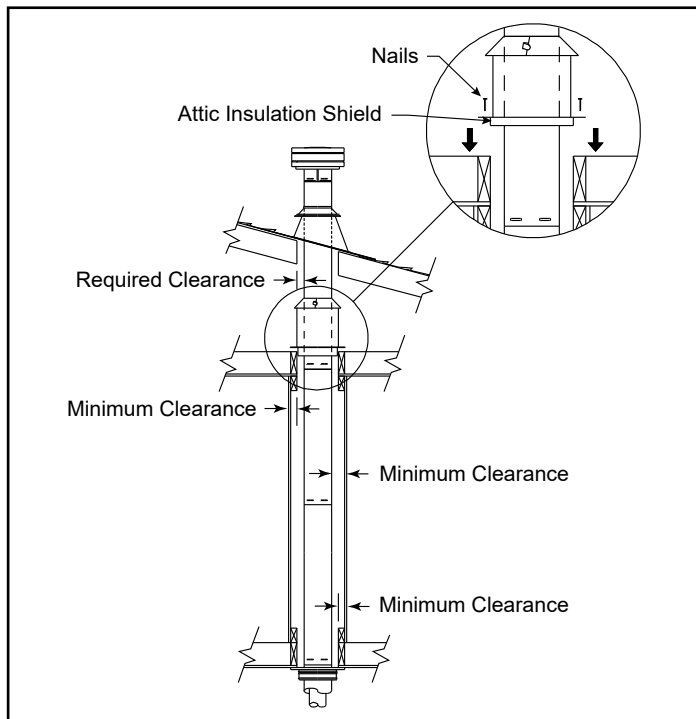

Figure 3.38

Cathedral Ceiling Installation

Step 1 - Follow installation Step 1 and 2 under Vertical Termination.

Step 2 - Using the plumb bob, mark the centerline of the venting system on the ceiling and drill a small hole through the ceiling and roof at this point. From the roof, locate the drill hole and mark the outline of the Cathedral Ceiling Support Box.

Step 3 - Remove shingles or other roof covering as necessary to cut the rectangular hole for the support box. Cut the hole 1/8" (3 mm) larger than the support box outline.

Step 4 - Lower the support box through the hole in the roof until each side of the bottom of the support box protrudes at least 2" (51 mm) below the ceiling, Figure 3.39. Align the support box both vertically and horizontally with a level. Temporarily tack the support box in place through the inside walls and into the roof sheathing.

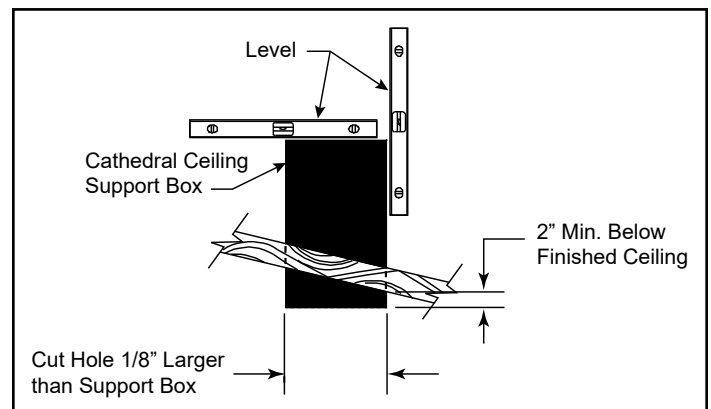

Figure 3.39

Step 5 - Using tin snips, cut the support box from the top corners down to the roofline, and fold the resulting flaps over the roof sheathing. The flaps may be trimmed as needed, Figure 3.40. Before nailing it to the roof, run a bead of non-hardening sealant around the support box to make a seal between the support box and the roof. Clean out any combustible material from inside the support box.

Step 6 - Follow Steps 4 and 5 of the Vertical Installation instructions.

Step 7 - Place the support clamp (provided with the support box) inside the support box (at the bottom), and secure to the pipe section. The clamp allows the support box to support the weight of the pipe sections. Continue to add pipe sections until you are above the roofline.

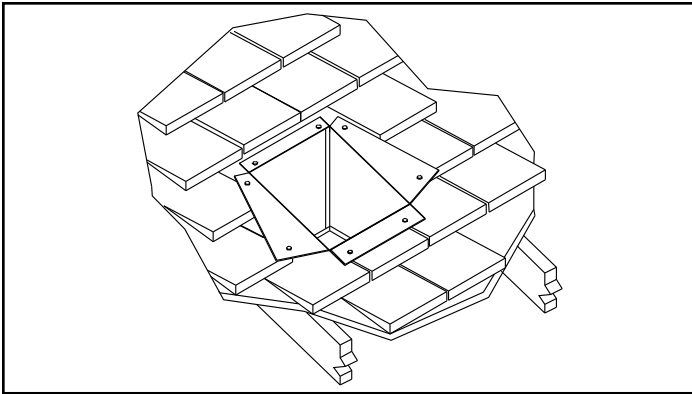

Figure 3.40

Step 8 - Follow Steps 7 through 10 of the Vertical Installation instructions

Step 9 - Install the black trim collar around the outside of the Cathedral ceiling support box. The two pieces of the trim collar slide over one another to allow for easy adjustment around the support box. Using the six (6) screws provided, secure the four corners and the overlapping sections of the trim collar to the underside of ceiling. You may want to predrill the holes for the overlapped sections for ease of installation, Figure 3.41.

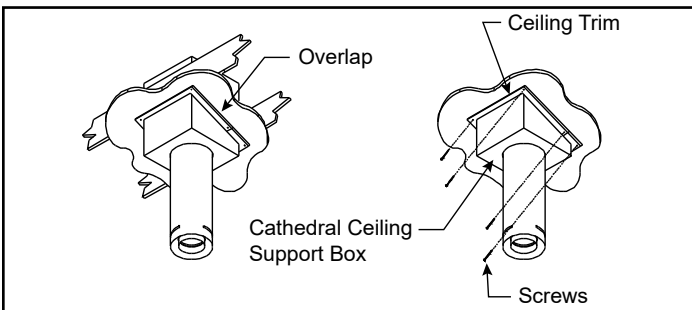

Figure 3.41

General Maintenance

Conduct an inspection of the venting system annually. Recommended areas to inspect are as follows:

1. Check areas of the venting system which are exposed to the elements for corrosion. These will appear as rust spots or streaks, and in extreme cases, holes. These components should be immediately replaced.
2. Remove the vertical terminations cap and shine a flashlight down the vent. Remove any bird nests, or other foreign material.
3. Check for evidence of excessive condensation, such as water droplets forming in the inner liner, and subsequently dripping out at joints. Continuous condensate can cause corrosion of caps, pipe and fittings. It may be caused by having excessive lateral runs, too many elbow and exterior portions of the system being exposed to cold weather.

4. Inspect joints to verify that no pipe sections or fittings have been disturbed or loosened. Also check mechanical supports such as wall straps or plumbers tape for rigidity.

Supplemental Canadian Instructions

When installing DirectVent Pro on appliances in Canada, a 2-piece decorative wall thimble is required in order to comply with IR #39, Figure 3.2 and 3.3. Install galvanized exterior wall thimble plate on exterior of building and black decorative wall thimble plate on the interior side of wall. Install wall thimble centered through a square framed opening in wall. Be sure to maintain all minimum clearances. When installing DirectVent Pro vertically through floors, a ceiling firestop is required at every floor/ceiling level.

Vertical Through Existing Chimney

The heater must be vented to the outdoors through an existing masonry or prefabricated fireplace chimney system through the roof.

The heater is approved to be vented to the outdoors through any solid-fuel fireplace chimney that has been constructed or installed in accordance with the national, Provincial/State and local building codes and is constructed of noncombustible materials.

Converting a Class-A Metal Chimney or Masonry Chimney to a Direct Vent System

Application

These instructions apply to the DuraVent Direct Vent Conversion kits for factory-built Class-A metal chimneys and masonry chimneys. These venting systems, in combination with the gas appliance, have been tested and listed by a major testing agency such as UL, AGA, Omni or Warnock Hersey. Check the manufacturer's rating plate and instruction manual to confirm that a DuraVent Direct Vent Chimney Conversion system is approved for use on the brand name appliance you have selected.

IMPORTANT

Read all instructions carefully before starting the installation. Failure to follow these instructions may create a fire or other safety hazard, and will void the warranty. Be sure to check the appliance manufacturer's installation instructions for specific venting and clearance to combustible requirements, which may vary from one appliance to another.

Installation Precautions

The DuraVent Direct Vent System is an engineered product that has been designed and tested for use with an approved list of direct vent gas appliances. The DuraVent warranty will be voided, and serious fire, health or other safety hazards may result from any of the following actions:

- Installation of any damaged Direct Vent component.
- Unauthorized modification of the Direct Vent System.
- Installation of any component part not manufactured or approved by DuraVent.
- Installation other than as instructed by DuraVent and the appliance manufacturer.

Consult your local building codes before beginning the installation. Have the existing installation inspected by a qualified chimney sweep or professional installer, prior to converting to direct vent. The existing chimney system must be in serviceable condition, and functionally sound.

The direct vent conversion described herein applies only to factory-built metal ceiling-supported type systems and masonry through-the-wall type systems. NOTE: You cannot install a Conversion Kit in a through-the-wall type factory-built metal chimney.

General Installation

Two different types of direct vent conversion systems are described here. One is through an existing factory-built metal chimney going through the ceiling. The other is through the wall of an existing masonry chimney. Follow the appropriate directions for your situation.

The concept of the direct vent conversion is to connect an adapter to an Underwriters Laboratories listed 4" diameter aluminum flex pipe (DuraVent's DuraFlex is an example of a UL listed flex pipe). The flex is then passed down through the center of the existing metal chimney system. Three sizes of termination caps are available which should fit most sizes and makes of metal chimney systems. The Retro Connector is then attached to the bottom of the flex pipe. Both the cap adapter and retro connector are attached to the existing chimney with sheet metal screws. The appliance is then connected to the chimney with appropriate black direct vent pipe and an adjustable length section.

There are several options to utilize an existing masonry chimney using Co-Linear Vent Adapter or a flex liner. Refer to Figure 3.54 for approved installations and venting components required.

Installation Instructions for Converting a Factory-Built Metal Chimney

1. Remove the existing chimney cap.
2. Measure the distance from the top end of the chimney to the bottom of the ceiling support box, add 3" to this measurement and cut a section of 4" flex pipe to that length (the flex should already be extended to its nominal length).
3. Connect the end of the flex pipe section to the underside of the cap adapter you have selected using three (3) sheet metal screws, Figure 3.45.

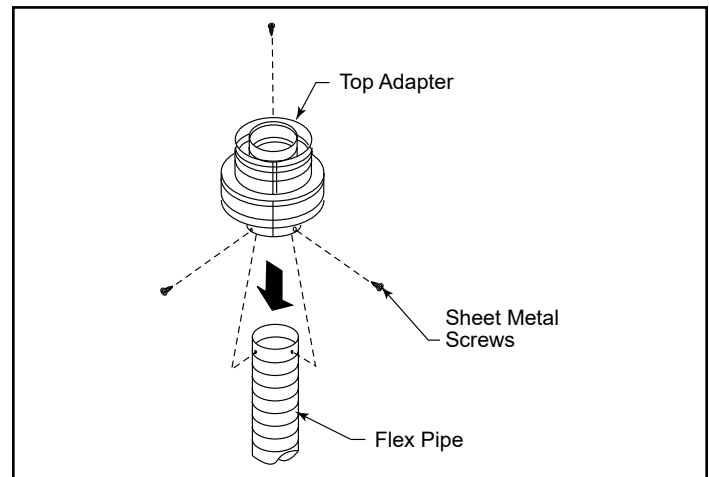

Figure 3.45

4. Pass the flex pipe down through the center of the chimney system, and center the adapter on the top of the chimney pipe. Drill four (4) 1/8" diameter holes through the adapter and into the chimney top. Insure that you are in fact, drilling into the metal on the chimney. Twist-lock the termination cap (980, 991 or 930) onto the adapter, Figures 3.46 and 3.47.

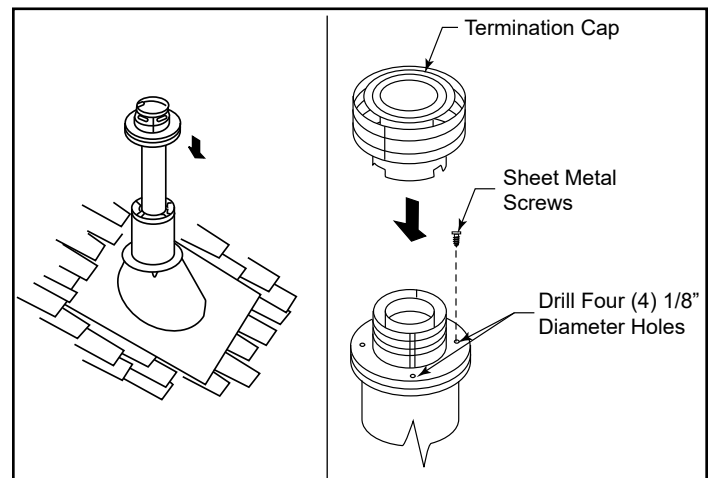

Figure 3.46

Figure 3.47

5. Pull the flex pipe down through the ceiling support box, until it protrudes approximately 3" (76 mm). Connect the flex pipe to the retro connector by slipping it into the 4-3/4" (121 mm) diameter sleeve on the top side of the connector. Use three (3) sheet metal screws to assemble these two parts.

6. Push the flex pipe back up into the ceiling support box, center the retro connector and attach it to the support box or decorative sleeve for double wall solid packed pipe, with the sheet metal screws furnished. The holes in the retro connector are pre-punched, Figure 3.48.
7. The connection between the appliance and the retro connector may be completed with sections of black direct vent pipe, together with an adjustable length.

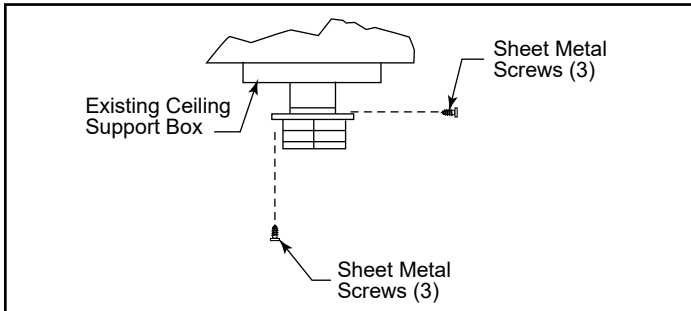

Figure 3.48

Installation Instructions for Converting a Masonry Chimney

IMPORTANT: The existing masonry flue opening need to have an area of at least 35 square inches (226 square mm) to insure proper intake/exhaust flow.

1. Before cutting any holes, assemble the desired sections of black direct vent pipe to determine the center of the masonry penetration.
2. Once the center point of the penetration has been determined, cut a 6" (152 mm) diameter hole in the masonry. Be careful, if the hole is too large, the retro connector might not mount properly. If the hole is too small, then the appliance might starve for intake air. If there is a frame wall in front of the masonry wall, cut and frame a 10" (254 mm) clear square opening in the wall (centered around the 6" (152 mm) masonry opening). If there is sheet rock only (no studs) in front of the masonry, the 10" (254 mm) clear opening is still needed, but does not need to be framed. This allows the retro connector to mount directly on the masonry and provide clearance to the combustibles, Figure 3.35.
3. Secure the flashing (705C) to the top of the masonry chimney using a bead of non-hardening sealant-adhesive. If the flashing is larger than the top of the chimney, then cut and fold flashing as needed to fit chimney, Figure 3.49.

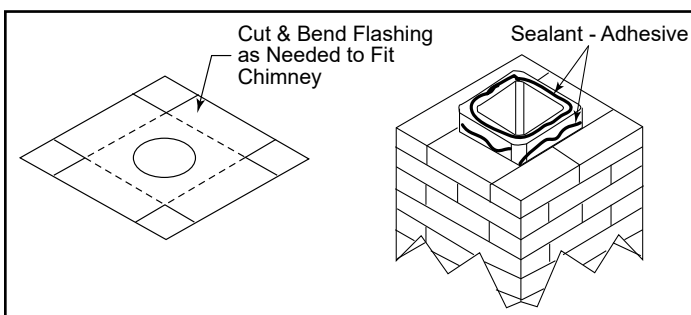

Figure 3.49

4. To determine the length of flex required, measure from 3" (76 mm) above the top of the flashing down to the level of the opening. Add to this measurement the distance from the center of the chimney to out through the wall. Cut a piece of 4" (102 mm) flex to this length (the flex should already be extended to its nominal length).
5. Connect the 4" flex liner to the cap adapter (985K) using three sheet metal screws, Figure 3.47.
6. Feed the 4" flex liner through the flashing into the chimney. Continue to feed the liner out through the opening in the masonry wall.
7. Secure the cap adapter to the flashing. Use three (3) sheet metal screws through the side of the adapter into the flange on the flashing as shown in Figure 3.50. Twist-lock the termination cap (980,991, 930) on to the cap adapter.

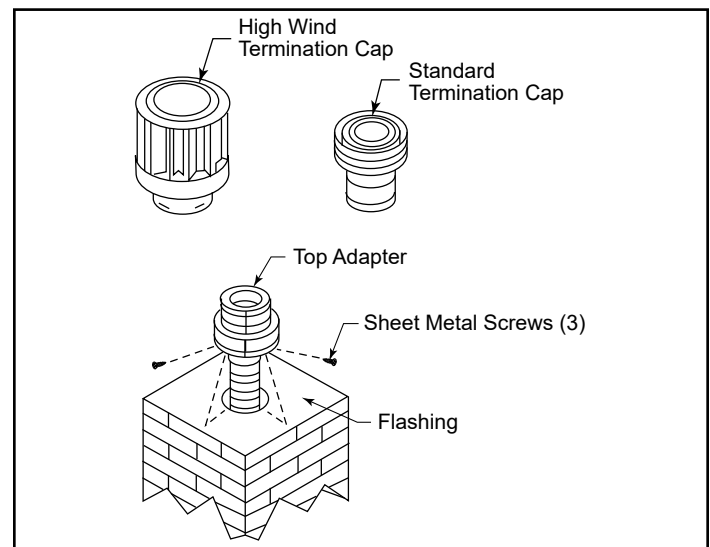

Figure 3.50

8. Attach the flex to the retro connector. Use three sheet metal screws to attach the flex liner to the connector, Figure 3.51. Mount the retro connector to the masonry wall using masonry bolts. Re-drill larger holes on connector as needed. Be careful to insure that the connector is centered in the opening and the mounting holes line up with the masonry wall.

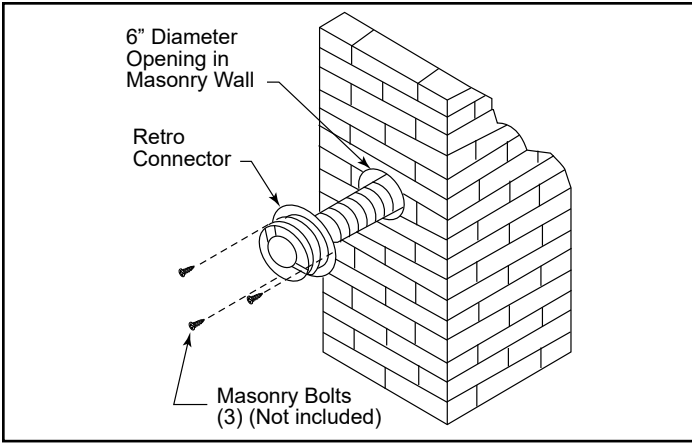

Figure 3.51

9. Slide the wall thimble cover (940) over the retro connector and secure the with masonry bolts as shown in Figure 3.52. If you have a framed wall in front of the masonry, use wood screws to mount the wall thimble cover to the framed wall, over the retro connector and the 10" (254 mm) square framed opening as shown in Figure 3.53. If needed, add a section of direct vent pipe to the retro connector in order to extend through the opening in the wall thimble cover.

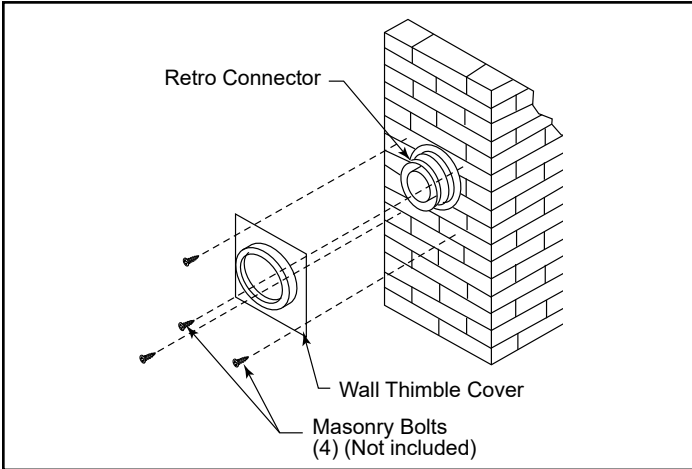

Figure 3.52

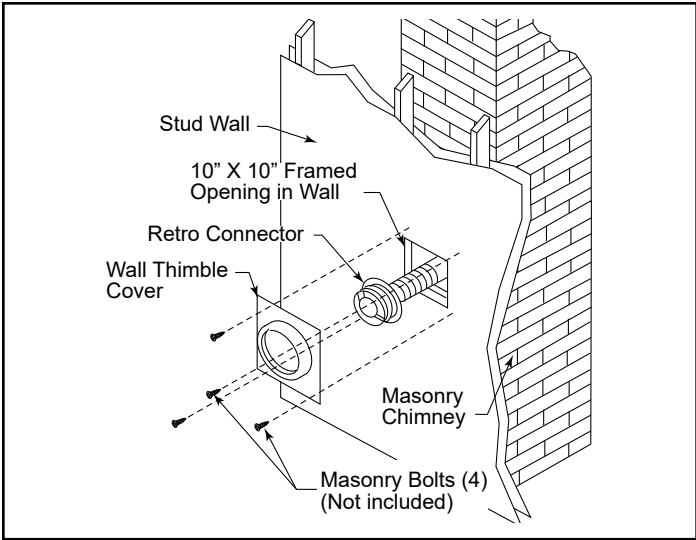

Figure 3.53

10. The connection between the appliance and the retro connector may be completed with the section of black direct vent pipe, together with an adjustable length pipe section.

Existing Masonry Chimney

Prior to installing the gas stove, ensure that the existing chimney is functionally sound and clean.

- Have the chimney and adjacent structure inspected and cleaned by qualified professionals. Hearth & Home Technologies recommends that NFI or CSIA certified professionals, or technicians under the direction of certified professionals, conduct a minimum of a NFPA 211 Level 2 inspection of the chimney.
- Replace component parts of the chimney and fireplace as specified by the professionals.
- See Section 11 for venting components.

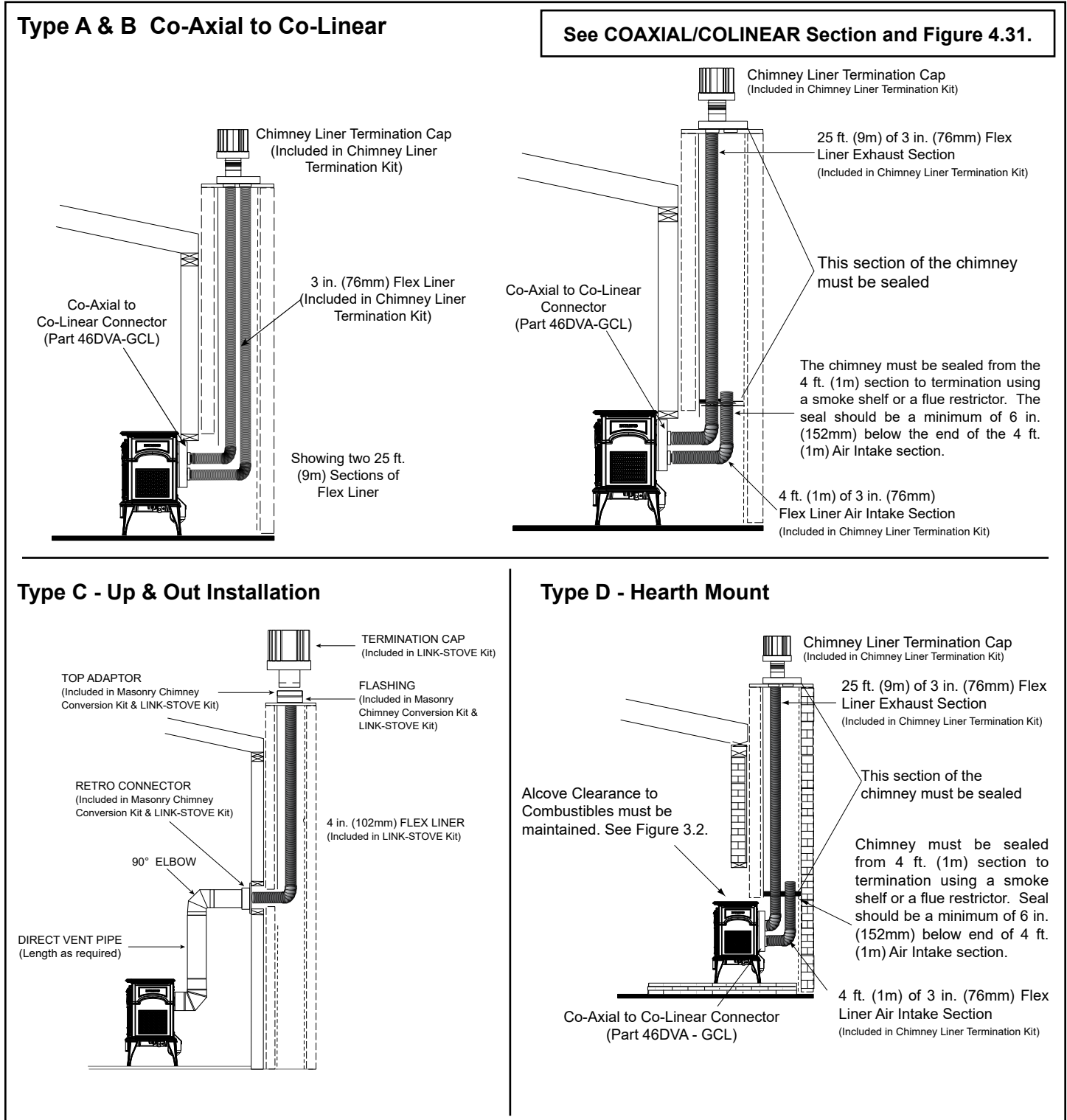

Connect the Gas Supply Line

Check the rating plate attached by a steel cable to the firebox, to confirm that you have the appropriate firebox for the type of fuel to be used.



CAUTION

This appliance should only be connected by a qualified gas technician. Test to confirm manifold pressures as specified below.

The Intrepid Heater and the individual shutoff valves must be disconnected from the gas supply piping during any pressure testing of that system at test pressures in excess of 1/2 psig (3.5 kPa).

The Intrepid Heater must be isolated from the gas supply piping system by closing the individual manual shutoff valve during any pressure testing of the gas supply piping system at test pressure equal to or less than 1/2 psig.

There must be a gas shutoff between the stove and the supply.

In order to connect Natural Gas, use a fitting with 3/8" NPT nipple on the valve side and 1/2" natural gas supply line with a minimum input of 21,000 BTUs at a minimum inlet pressure of 5.5" w.c.

In order to connect Propane, use a fitting with 3/8" NPT nipple on the valve side and 1/2" propane gas supply line with a minimum input of 21,000 BTUs at a minimum inlet pressure of 11.0" w.c.

In the U.S.: Gas connection should be made in accordance with current National Fuel Gas Code, ANSI Z223.1/NFPA 54. Since some municipalities have additional local codes, be sure to consult your local authority.

In Canada: consult the local authority and CSA-B149.1 installation code.

Connect the gas supply and test for leaks. Use a mild soap and water solution applied with a brush no larger than 1" (25 mm). Never apply soap and water solution with a spray bottle. Do not use an open flame for leak testing.

Burner Information

The appliance must only use the gas specified on the rating plate, unless converted using a Vermont Castings Fuel Conversion Kit. Conversion instructions are provided with each kit.

THIS APPLIANCE SHOULD BE CONNECTED TO THE GAS SUPPLY ONLY BY A QUALIFIED GAS SERVICE TECHNICIAN. FOLLOW ALL LOCAL CODES. THERE MUST BE A GAS SHUT-OFF BETWEEN THE STOVE AND THE SUPPLY.

Complete the Assembly

- Open the swiveling latches (cams) on the top left and right corners of the glass frame.
- Position the glass and frame against the firebox by placing the bottom edge on the brackets on the bottom face of the firebox.
- Swing the assembly against the firebox, and close the latches firmly against the pins protruding from the firebox top.

Install the Front Plate

Grasp the Front Plate and lift it into position, engaging the two steel tabs at the upper corners behind the adjacent bosses in the Side Plates, Figure 3.57. Seat the Front against the Sides so that the tabs at the bottom lip engage with the notches in the edge of the stove base.

When properly installed, the bottom of the Front Plate cannot be pulled away from the sides without also lifting it up.

If you are installing optional Warming Shelves, do so now, according to the instructions supplied with that kit.

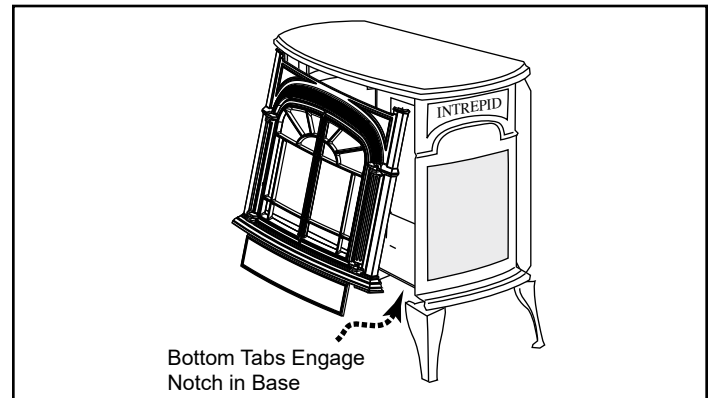

Figure 3.57 - Install stove front.

Thermostat Connection (Optional)

Use only a thermostat rated for 500 - 750 millivolts.

Check the table below for the appropriate gauge thermostat wire to use for the length of lead required in your installation.

Thermostat Wire / Gauge	Maximum Run
18	40 Feet
20	25 Feet
22	16 Feet

1. Install the wall thermostat in the desired location and run the wires to the stove location. Terminate these leads with 1/4" female connectors.
2. Connect the thermostat wires to the valve, Figure 3.56.

This completes assembly of the Intrepid stove.

D. Log Set Installation

Before beginning log installation, remove stove front and glass frame, Figure 3.58.

Note: Remove the safety barrier before you remove the glass frame. To remove the barrier, simply lift up and pull out until the tabs are clear of their corresponding slots on the firebox. Then proceed to remove the glass frame by following the steps below.

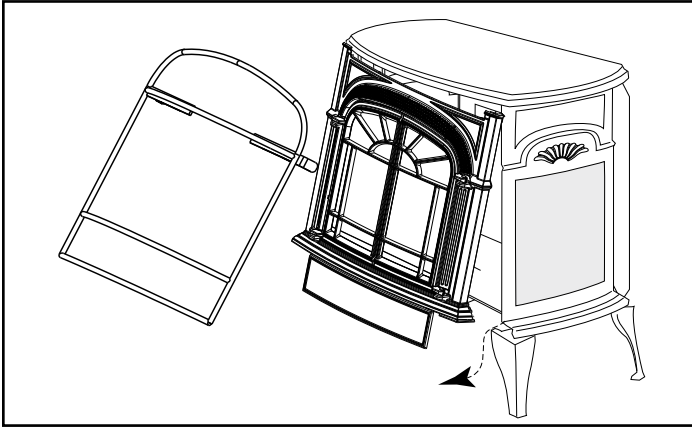

Figure 3.58 - Remove stove front.



DANGER



HOT GLASS WILL CAUSE BURNS.

DO NOT TOUCH GLASS UNTIL COOLED.

NEVER ALLOW CHILDREN TO TOUCH GLASS.

A barrier designed to reduce the risk of burns from the hot viewing glass is provided with this appliance and must be installed.

Before installation, inspect ember bed burner for damage. Do not use ember bed if damaged or cracked. Small, shallow surface cracks are acceptable.

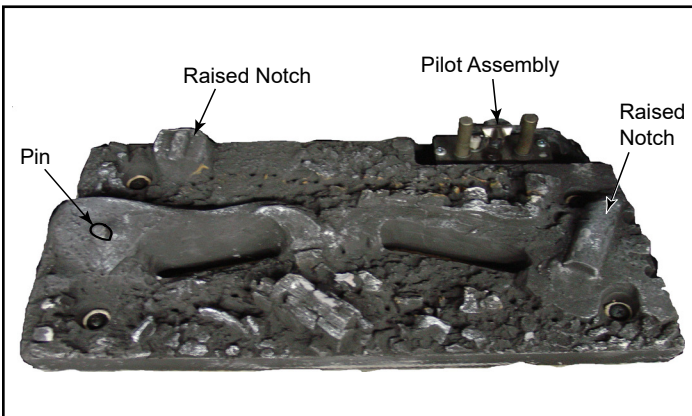

Figure 3.59 - Ribs for Logs

1. Remove the logs from their packaging and inspect each piece for damage. **DO NOT INSTALL DAMAGED LOGS.**
2. Install the rear log by matching the notch on the bottom left of the log on the raised notch on back left side of the ember bed. Cutout on bottom right side is clearance for pilot assembly, Figure 3.60. Gently push right side of log back until it contacts the firebox back, slightly pull forward until seated.

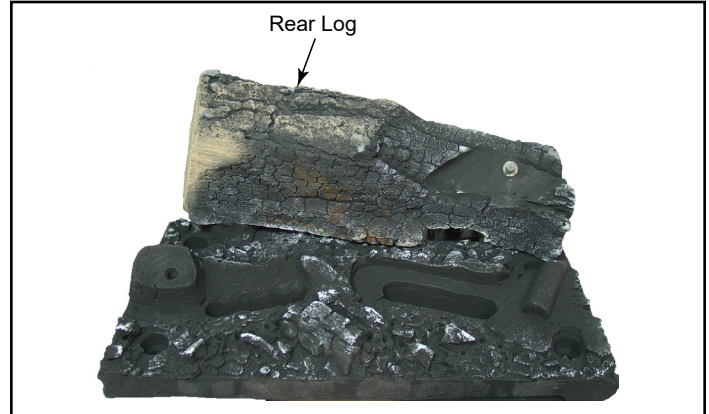

Figure 3.60 - Rear Log

3. Place the left front log on the pin locator on ember bed. Position the log over the air inlet hole and on notched out portion of ember bed, Figure 3.61.
4. Place front right log on ember bed by mating notch on bottom of log with raised notch on ember bed. Position over the air inlet hole and on notched out portion of ember bed, Figure 3.61.

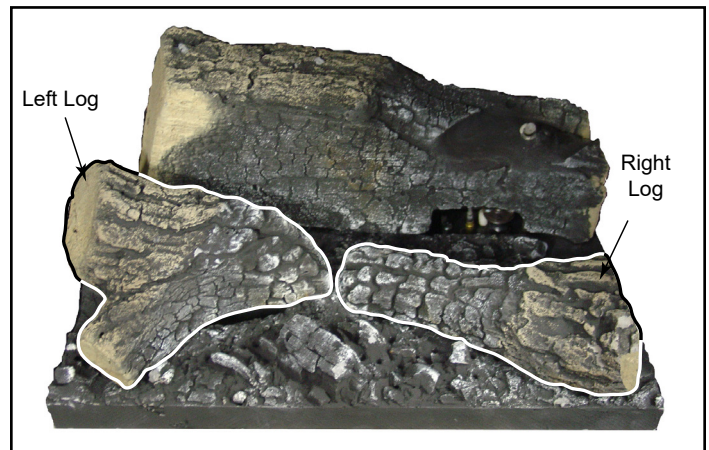

Figure 3.61 - Front Logs

5. Install top log by mating hole on bottom of log with locating pin on top right side of rear log, Figure 3.62. Position log so it is angled down toward the area where the front two logs meet.

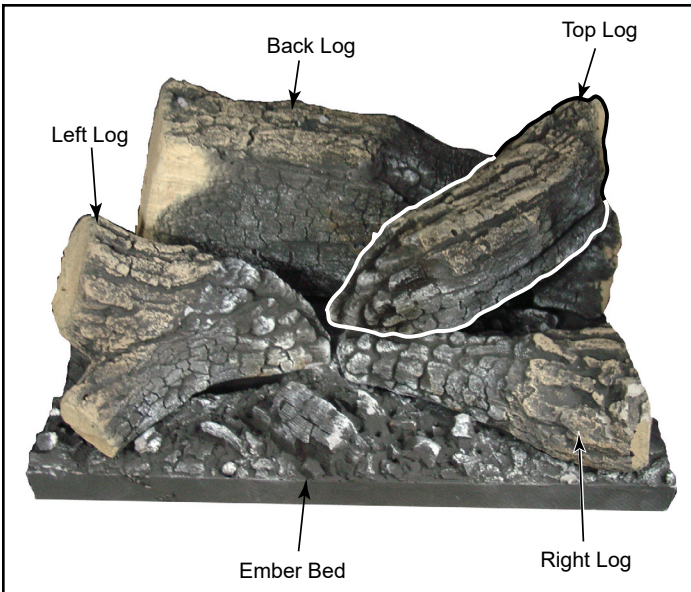

Figure 3.62 - Top Log

E. Thermostat Connection (optional):

Use only a thermostat rated for 500 - 750 millivolts.

Check the table below for the appropriate gauge thermostat wire to use for the length of lead required in your installation.

Thermostat Wire / Gauge	Maximum Run
18	20 Feet
16	20 - 40 Feet
14	up to 60 Feet

1. Install the wall thermostat in the desired location and run the wires to the stove location. Terminate these leads with 1/4" female connectors.
2. Connect the thermostat or wall switch wires to the valve, Figure 3.63.

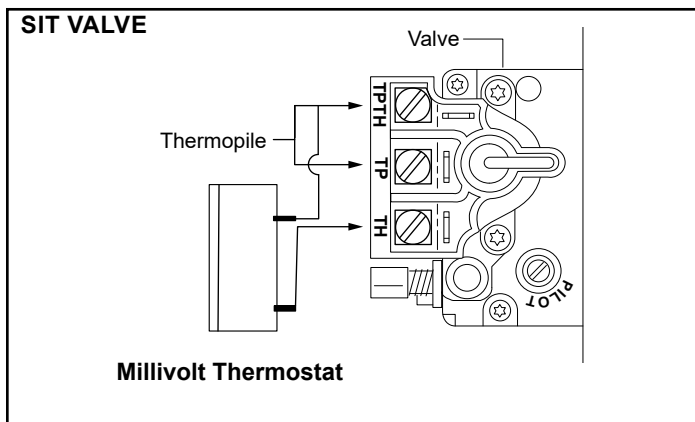

Figure 3.63- Install wiring to Thermostat before connecting to valve.

⚠ WARNING

Electrical connections should only be performed by a qualified, licensed electrician. Main power must be off when connecting to main electrical power supply or performing service. All wiring shall be in compliance with all local, city and state codes. The appliance, when installed, must be electrically grounded in accordance with local codes or in the absence of local codes, with the National Electrical Code ANSI/NFPA 70 (latest edition) and Canadian Electrical Code, CSA C22.1.

⚠ CAUTION

Label all wires before disconnecting when servicing controls. Wiring errors can cause improper and dangerous operation.

⚠ WARNING

Do not connect wall switch to 110 V circuit.

⚠ CAUTION

Electrical connections should only be performed by a qualified, licensed electrician. Main power supply must be turned off before connecting fans to the main electrical power supply or performing service.

⚠ WARNING

Electrical Grounding Instructions: This appliance is equipped with a three-prong (grounding) plug for your protection against shock hazard and should be plugged directly into a properly grounded three-prong receptacle.

Connect the Gas Supply Line

Check the Rating Plate attached by a steel cable to the firebox, to confirm that you have the appropriate firebox for the type of fuel to be used. The Intrepid DV may be converted from one gas to another using the appropriate Fuel Conversion Kit listed in this manual under Replacement Parts.

In the U.S.; Gas connection should be made in accordance with current National Fuel Gas Code, ANSI Z223.1/NFPA 54. Since some municipalities have additional local codes, be sure to consult your local authority.

In Canada; consult the local authority and CSA-B149.1 installation code.

NOTE: Always check for gas leaks with a mild soap and water solution. Do not use an open flame for leak testing.

Light the pilot according to the directions in the Operation section of this manual.



CAUTION

This appliance should only be connected by a qualified gas technician. Test to confirm manifold pressures as specified below.

The Intrepid DV Heater and its individual shutoff valve must be disconnected from the gas supply piping during any pressure testing of that system at test pressures in excess of 1/2 psig (3.5 kPa).

The Intrepid DV Heater must be isolated from the gas supply piping system by closing its individual manual shutoff valve during any pressure testing of the gas supply piping system at test pressure equal to or less than 1/2 psig.

There must be a gas shutoff between the stove and the supply.

In order to connect Natural Gas, use a fitting with 1/2" NPT on the valve side and 1/2" natural gas supply line with an input of 38,000 BTUs at a manifold pressure of 3.5" between minimum inlet supply of 5.5" w.c. and maximum of 10.0" w.c.

In order to connect Propane, use a fitting with 1/2" NPT on the valve side and 1/2" propane gas supply line with an input of 36,000 BTUs at a manifold pressure of 10.0" between a minimum inlet supply of 11.0" w.c. and maximum of 13.0" w.c.

THIS APPLIANCE SHOULD BE CONNECTED TO THE GAS SUPPLY ONLY BY A QUALIFIED GAS SERVICE TECHNICIAN. FOLLOW ALL LOCAL CODES.

THERE MUST BE A GAS SHUT-OFF BETWEEN THE STOVE AND THE SUPPLY.

F. INDVR-IFT Wiring Requirements

Intellifire™ Touch Ignition System Wiring

- Wire the appliance junction box to 110-120 VAC for proper operation of the appliance.

WARNING! Risk of Shock or Explosion! DO NOT wire IFT controlled appliance junction box to a switched circuit. Incorrect wiring will override IFT safety lockout.

- Refer to Figure 3.60, IFT Wiring Diagram.
- This appliance is equipped with an Intellifire™ Touch control valve which operates on a 6 volt/1.5 AMP system.
- Plug the 6 volt transformer plug into the appliance junction box to supply power to the unit OR install 4 AA cell batteries (not included) into the battery pack before use.

NOTICE: Batteries should only be used as a power source in the event of an emergency power outage. Batteries should not be used as a primary long-term power source. Battery polarity must be correct when installing batteries. When using batteries as a power source, the 6-volt transformer must be unplugged from the receptacle.

Do not store batteries in the battery pack when the appliance is powered by the 6 volt transformer connected to permanent electrical service.

Accessories Requirements

- This appliance ships standard with a remote control. Wiring for optional Hearth & Home Technologies approved accessories should be done now to avoid reconstruction. Follow instructions that come with those accessories.

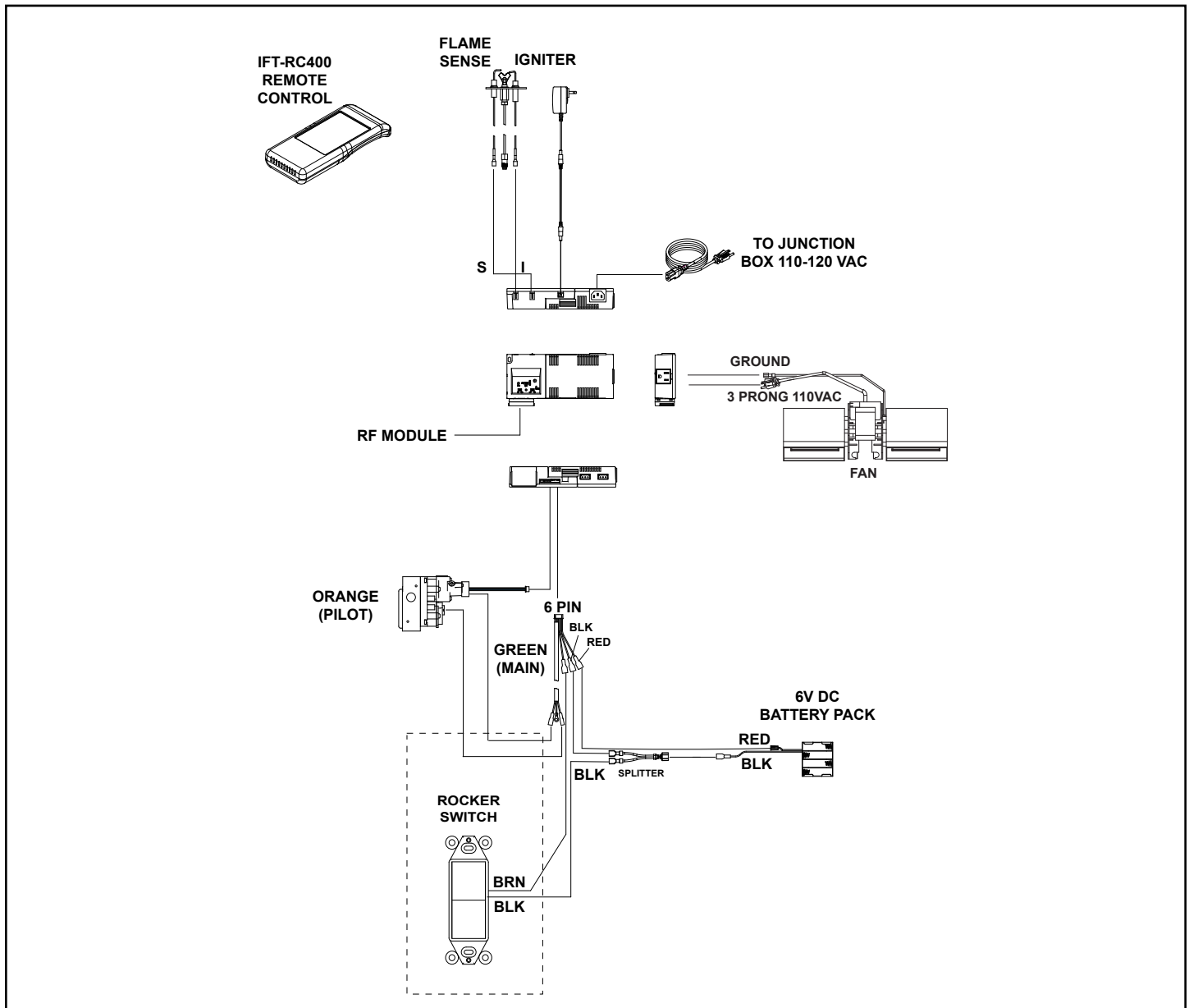

Figure 3.60 - INDVR-IFT Wiring Diagram

G. Install the Safety Barrier



NOTE: A barrier designed to reduce the risk of burns from the hot viewing glass is provided with this appliance and shall be installed for the protection of children and other at risk individuals. If the barrier becomes damaged, the barrier shall be replaced with the manufacturer's barrier for this appliance.* Any safety screen, guard, or barrier removed for servicing the appliance must be replaced prior to operating the appliance.

* See parts list for model number.

The safety barrier has been designed to work with the doors open or closed.

1. Remove screen from packaging.
2. Place the two bottom hooks over the bottom edge of the stove opening, Figure 3.61.
3. Press the screen against the stove snapping the two spring fingers until the screen fits securely in place.

NOTE: It is the responsibility of the installer to ensure the barrier is affixed to the stove at the time of installation.

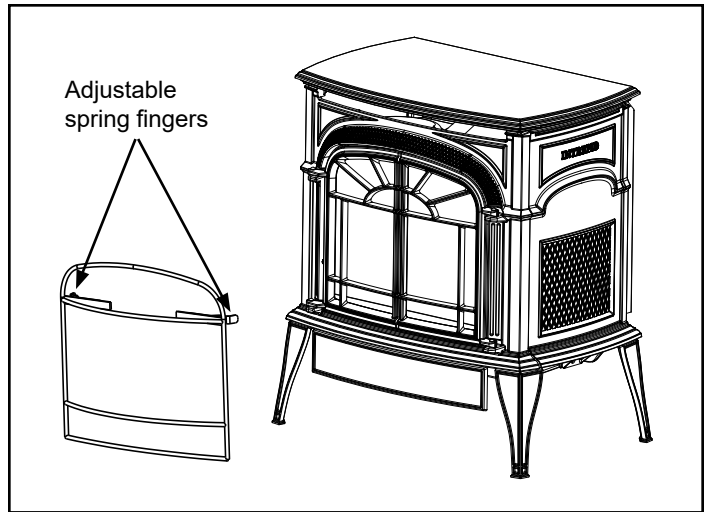

Figure 3.61 - Install safety barrier screen.

WARNING

The safety screen barrier must be installed after the glass front is in place. It is not a replacement for the glass and the unit must not be operated without the glass in place.

H. Install the Mesh and Grille

Place the mesh and grille on the top of the Intrepid DV stove to complete assembly.



DANGER



HOT GLASS WILL CAUSE BURNS.

DO NOT TOUCH GLASS UNTIL COOLED.

NEVER ALLOW CHILDREN TO TOUCH GLASS.

A barrier designed to reduce the risk of burns from the hot viewing glass is provided with this appliance and must be installed.

4 Operating Instructions

A. Operation

The Intrepid DV is operated with the front plate in place with the doors open or closed. To open the front doors, pull forward to separate the magnetic catch. Ensure the safety barrier screen is in place during operation.

B. Lighting Instructions

Read these instructions carefully and familiarize yourself with the lighting instructions. Section F, "Lighting and Operating Instructions". Locate the pilot assembly, Figure 4.1. Follow the lighting instructions in this manual exactly.

During the first fire, it is not unusual to smell some odor associated with new logs, paint and metal being heated. Odors should dissipate within the first eight to ten hours, however, you can open a window to provide fresh air to alleviate the condition.

C. Pilot and Burner Inspection

Each time you light your heater check that the pilot flame and burner flame patterns are as shown in Figure 4.2. If flame patterns are incorrect, turn the heater off. Contact your dealer or a qualified gas technician for assistance. Do not operate the heater until the pilot flame is correct.

Follow regular maintenance procedures as described in the Cleaning and Maintenance section of this manual.

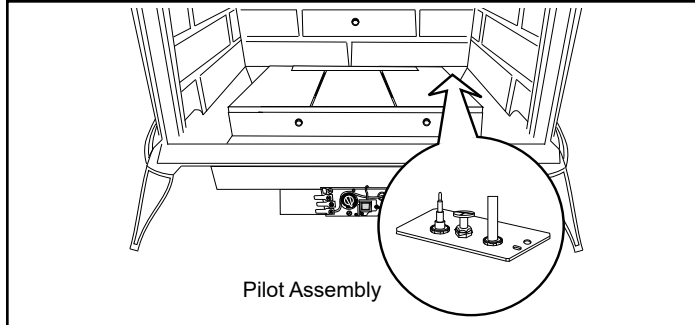

Figure 4.1 - Pilot Assembly location.

D. Flame Characteristics

It is important to periodically perform a visual check of the pilot and the burner flames. Compare them to Figure 4.2. If any of the flames appear abnormal, call a service person.



INDVR MODELS

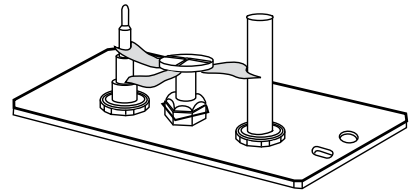

INDVR-IFT

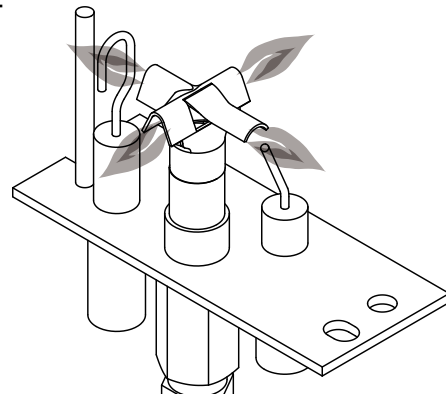

Figure 4.2 - Correct pilot and burner flame appearance.

E. Flame & Temperature Adjustment

For INDVR models which are equipped with HI/LO valves, flame adjustment is accomplished by rotating the HI/LO adjustment knob located near the center of the gas control valve, Figure 4.3.

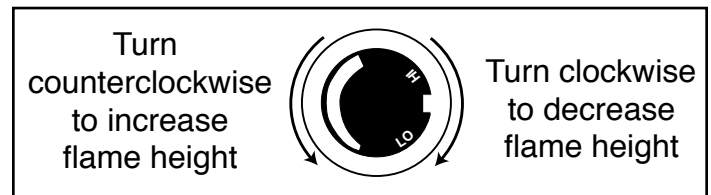

Figure 4.3 - Flame adjustment knob for SIT valve.

F. Lighting and Operating Instructions - Millivolt



LIGHTING AND OPERATING INSTRUCTIONS FOR INDVR MODELS (MILLIVOLT ONLY)

FOR YOUR SAFETY READ BEFORE LIGHTING

WARNING: If you do not follow these instructions exactly, a fire or explosion may result causing property damage, personal injury or loss of life.

- A. This heater has a pilot which must be lit manually. When lighting the pilot follow these instructions exactly.
- B. BEFORE LIGHTING smell all around the heater area for gas. Be sure to smell next to the floor because some gas is heavier than air and will settle on the floor.
- WHAT TO DO IF YOU SMELL GAS**
- Do not try to light any stove
 - Do not touch any electric switch
 - Do not use any phone in your building
 - Immediately call your gas supplier from a neighbor's phone. Follow the gas supplier's instructions.
 - If you cannot reach your gas supplier, call the Fire Department
- C. Use only your hand to push in or turn the gas control knob. Never use tools. If the knob will not push in or turn by hand, do not try to repair it, call a qualified service technician. Applying force or any attempted repair may result in a fire or explosion.
- D. Do not use this stove if any part has been under water. Immediately call a qualified service technician to inspect the heater and to replace any part of the control system and any gas control which has been under water.

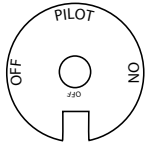
Lighting Instructions

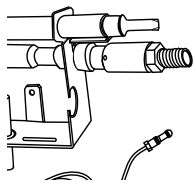
1. **STOP!** Read the safety information above.
 2. Turn off all electrical power to the stove.
 3. Turn the On/Off switch to "OFF" position, set the remote to OFF or set thermostat to lowest level.
 4. Open control access panel.
 5. Push in gas control knob slightly and turn clockwise  to "OFF".
- 
- SIT NOVA**
6. Wait five (5) minutes to clear out any gas. Then smell for gas, including near the floor. If you smell gas, STOP! Follow "B" in the safety information above. If you do not smell gas, go to the next step.
 7. Remove glass door before lighting pilot. (See Glass Frame Removal section).
 8. Visibly locate pilot by the main burner.
 9. Turn knob on gas control counter-clockwise  to "PILOT".
 10. Push the control knob all the way in and hold. Immediately light the pilot by repeatedly depressing the piezo spark ignitor until a flame appears. Continue to hold the control knob in for about one (1) minute after the pilot is lit. Release knob and it will pop back up. Pilot should remain lit. If it goes out, repeat steps 5 through 8.
- 
- If knob does not pop up when released, stop and immediately call your service technician or gas supplier.
 - If after several tries, the pilot will not stay lit, turn the gas control knob to "OFF" and call your service technician or gas supplier.
11. Replace glass door.
 12. Turn gas control knob to "ON" position.
 13. Turn the On/Off switch to "ON" position or set thermostat to desired setting.
 14. Turn on all electrical power to the stove.

To Turn Off Gas To Heater

1. Turn the On/Off switch to Off position or set the thermostat to lowest setting.
2. Turn off all electric power to the stove if service is to be performed.
3. Open control access panel.
4. Push in gas control knob slightly and turn clockwise  to "OFF". Do not force.
5. Close control access panel.

G. Troubleshooting

Gas Control System (INDVR models)

SIT NOVA 820 Millivolt Valve

NOTE: Before trouble shooting the gas control system, be sure external gas shut off is in the “On” position.

Symptom	Possible Causes	Corrective Action
Spark Ignitor will not light	1. Defective or misaligned electrode at pilot	1. Using a match, light pilot. If pilot lights, turn off pilot and push the red button again. If pilot will not light - check gap at electrode and pilot-should be 1/8” to have a strong spark.
	2. Defective ignitor (push button)	2. With the control knob in the pilot position, push the control knob all the way and hold. Check for spark at electrode and pilot. If no spark to pilot, and electrode wire is properly connected, replace the battery in the ignitor module and try again. Refer to Maintenance Section. If the problem still exists, replace the ignitor module box.
Pilot will not stay lit after carefully following lighting instructions	1. Defective pilot generator (thermocouple), remote wall switch	1. Check pilot flame. Must impinge on thermocouple/thermopile. NOTE: This pilot burner assembly utilizes both a thermocouple and a thermopile. The thermocouple operates the main valve operation (On and Off). Clean and or adjust pilot for maximum flame impingement on thermopile and thermocouple.
	2. Defective automatic valve	2. Turn valve knob to “Pilot”. Maintain flow to pilot; millivolt meter should read greater than 10mV. If the reading is okay and the pilot does not stay on, replace the gas valve. NOTE: An interrupter block (not supplied) must be used to conduct this test.
Pilot burning, no gas to main burner	1. Wall switch or wires defective	1. Check wall switch and wires for proper connections. Jumper wire across terminals at wall switch, if burner comes on, replace defective wall switch.. If okay, jumper wires across wall switch wires at valve, if burner comes on, wires are faulty or connections are bad.
	2. Thermopile may not be generating sufficient millivoltage	<ul style="list-style-type: none"> • Be sure wire connections form thermopile at gas valve terminals are tight and thermopile is fully inserted into pilot bracket. • One of the wall switch wires may be grounded. Remove wall switch wires form valve terminals if pilot now stays lit, trace wall switch wiring for ground. May be grounded to stove or gas supply. • Check thermopile with millivolt meter. Take reading at thermopile terminals of gas valve. Should read 250-300 millivolts (minimum 150) while holding valve knob depressed in pilot position and wall switch “Off”. Replace faulty thermopile if reading is below specified minimum.
	3. Plugged burner orifice	3. Check burner orifices for debris and remove.
	4. Defective automatic valve operator	4. Turn valve knob to “On”, place wall switch to “On” millivolt meter should read greater than 150mV. If the reading is okay and the burner does not come on, replace the gas valve.
Frequent pilot outage problem	1. Pilot flame may be too low or blowing (high) causing the pilot safety to drop out	1. Clean and/or adjust pilot flame for maximum flame impingement on thermopile and thermocouple.
	2. Possible blockage of the vent terminal	2. Check the vent terminal for blockage (recycling the flue gases)

H. Read Before Lighting

FOR YOUR SAFETY READ BEFORE LIGHTING



WARNING

If you do not follow these instruction exactly, a fire or explosion may result causing property damage, personal injury or loss of life.

- A. This appliance is equipped with an ignition device which automatically lights the pilot. Refer to the instructions.
- B. BEFORE OPERATING smell all around the appliance area for gas. Be sure to smell next to the floor because some gas is heavier than air and will settle on the floor.

WHAT TO DO IF YOU SMELL GAS:

- Do not attempt to light any appliance.
 - Do not touch any electric switch; do not use any phone in your building.
 - Immediately call your gas supplier from a neighbor's phone. Follow the gas supplier's instructions.
 - If you cannot reach your gas supplier, call the fire department.
- C. Use only your finger to push in the master switch. Never use tools. If the switch will not function by hand, do not try to repair it. Call a qualified service technician. Force or attempted repair may result in a fire or explosion.
 - D. Do not use this appliance if any part of it has been under water. Immediately call a qualified service technician to inspect the appliance and to replace any part of the control system and any gas control that has been under water.

I. Lighting Instructions (IFT)

FOR YOUR SAFETY READ BEFORE LIGHTING



WARNING: If you do not follow these instructions exactly, a fire or explosion may result causing property damage, personal injury or loss of life.

- A. This appliance is equipped with an intermittent pilot ignition (IPI) device which automatically lights the burner. **DO NOT** try to light the burner by hand.
- B. **BEFORE LIGHTING**, smell all around the appliance area for gas. Be sure to smell next to the floor because some gas is heavier than air and will settle on the floor.
- WHAT TO DO IF YOU SMELL GAS**
- **DO NOT** try to light any appliance.
 - **DO NOT** touch any electric switch; do not use any phone in your building.
 - Immediately call your gas supplier from a neighbor's phone. Follow the gas supplier's instructions.
 - If you cannot reach your gas supplier, call the fire department.
- C. Use only your hand to push in or turn the gas control knob. Never use tools. If the knob will not push in or turn by hand, **DO NOT** try to repair it, call a qualified service technician. Force or attempted repair may result in a fire or explosion.
- D. **DO NOT** use this appliance if any part has been under water. Immediately call a qualified service technician to inspect the appliance and to replace any part of the control system and any gas control which has been under water.

LIGHTING INSTRUCTIONS (IPI)

1. This appliance is equipped with an ignition device which automatically lights the burner. **DO NOT** try to light the burner by hand.
2. Wait five (5) minutes to clear out any gas. Then smell for gas, including near the floor. If you smell gas, **STOP!** Follow "B" in the Safety Information located on the top of this label. If you do not smell gas, go to next step.
3. To light the burner:
Equipped with wall switch: Turn ON/OFF switch to ON.
Equipped with remote or wall control: Press ON or FLAME button.
Equipped with thermostat: Set temperature to desired setting.
4. If the appliance does not light after three tries, call your service technician or gas supplier.

**GAS
VALVE**

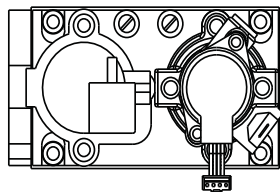

TO TURN OFF GAS TO APPLIANCE

1. Equipped with wall switch: Turn ON/OFF switch to OFF.
Equipped with remote or wall control: Press OFF button.
Equipped with thermostat: Set temperature to lowest setting.
2. Service technician should turn off electric power to the control when performing service.



DANGER



**HOT GLASS WILL CAUSE BURNS.
DO NOT TOUCH GLASS UNTIL COOLED.
NEVER ALLOW CHILDREN TO TOUCH GLASS.**

A barrier designed to reduce the risk of burns from the hot viewing glass is provided with this appliance and must be installed for the protection of children and other at-risk individuals.

WARNING:

DO NOT CONNECT LINE VOLTAGE (110/120 VAC OR 220/240 VAC) TO THE CONTROL VALVE.

Improper installation, adjustment, alteration, service or maintenance can cause injury or property damage. Refer to the owner's information manual provided with this appliance. For assistance or additional information, consult a qualified installer, service agency or the gas supplier.

This appliance needs fresh air for safe operation and must be installed so there are provisions for adequate combustion and ventilation air.



WARNING: This product and the fuels used to operate this product (liquid propane or natural gas), and the products of combustion of such fuels, can expose you to chemicals including benzene, which is known to the State of California to cause cancer and reproductive harm. For more information go to: www.P65Warnings.ca.gov.

Keep burner and control compartment clean. See installation and operating instructions accompanying appliance.

CAUTION:

Hot while in operation. **DO NOT** touch. Keep children, clothing, furniture, gasoline and other liquids having flammable vapors away.

DO NOT operate the appliance with fixed glass assembly removed, cracked or broken. Replacement of the fixed glass assembly should be done by a licensed or qualified service person.

NOT FOR USE WITH SOLID FUEL

For use with natural gas and propane. A conversion kit, as supplied by the manufacturer, shall be used to convert this appliance to the alternate fuel.

Also Certified for Installation in a Bedroom or a Bedsitting Room.

This appliance must be installed in accordance with local codes, if any; if none, follow the *National Fuel Gas Code, ANSI Z223.1/NFPA 54*, or the *National Gas and Propane Installation code, CSA B149.1*.

**For additional information on operating your
Hearth & Home Technologies fireplace, please
refer to www.hearthhome.com.**

593-913K

J. Operation During A Power Outage - IntelliFire™ Touch

The IntelliFire™ Touch intermittent pilot ignition system comes with a battery backup system that enables the system to operate in a power outage. The system offers seamless transition from household AC power to battery backup. A factory-installed battery pack is located in the control cavity of the appliance. Battery longevity and performance will be affected by long term exposure to the service temperatures of this appliance.

NOTICE: Batteries should only be used as a power source in the event of an emergency power outage. Batteries should not be used as a primary long-term power source.

To Operate Fireplace Using Battery Power (DC):

1. Access the control cavity of the appliance. The magnetic vanity plate may need to be removed.
2. Locate the battery tray (located on the back of the ECM bracket) and insert four AA cell batteries. Battery polarity must be correct or module damage will occur. A complete wiring diagram is included in the Electrical section of the appliance Installation Manual.
3. Turn the appliance on according to the instructions below for the appropriate type of control:

Standard Wall Switch:

- Toggle the switch as you would under normal circumstances.

Wireless Remote:

- Remote receiver is integrated into the ignition module
- Use the remote to turn the appliance on.
- To preserve battery life, do not use the HI/LO flame or THERMOSTAT options.

Ignition Module:

- Locate the ignition module in the control cavity.
- Slide the ON/REMOTE/OFF switch to the ON position

NOTICE: Some functionality will be lost when using battery backup including remote control, fan, lights, or any other auxiliary functions that require household 110-120 VAC power

To Return to Operation Using Electrical (AC) Power Standard Wall Switch or Factory-Installed ON/OFF

Switch:

- Toggle the switch to OFF and remove the batteries from the battery tray. Replace magnetic vanity plate on appliance.

Wireless Remote:

- Slide the ON / REMOTE / OFF switch to the REMOTE position. Remove the batteries from the battery tray. Replace decorative front on appliance.

Ignition Module:

- Slide the ON / REMOTE / OFF switch to the REMOTE position.
- Remove the batteries from the battery tray. Replace decorative front on appliance, Figure 4.5.

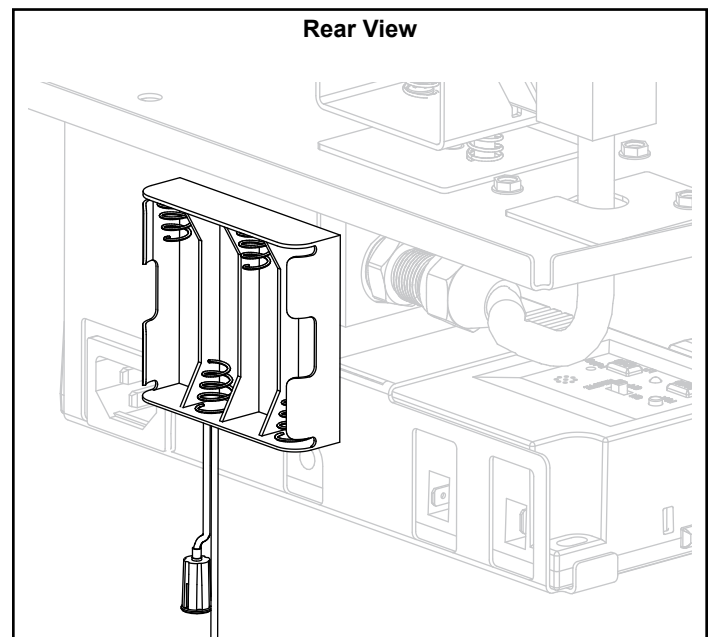

Figure 4.5 - Battery Holder

K. Detailed Component Operating Instructions - IntelliFire™ Touch

IFT-ECM Detailed Operating Instruction

This model is shipped from the factory equipped with the IFT-RC400 remote.

1. The Electronic Control Module (IFT-ECM) has a three-position ON/OFF/REMOTE selector switch that must be set for proper operation, Figure 4.6. When changing switch positions, it is important to pause in each position for 1-2 seconds.

OFF Position:

The appliance will not respond to any commands from a wired wall switch or IFT-RC400 remote controls. The unit should be in the OFF position during service, fuel conversion, and to reset the IFT-ECM in the event the system goes into a LOCK-OUT mode as the result of a system error. When switched to the OFF position while the appliance is operating, the system will shut down.

ON Position:

The appliance will ignite and run continuously at the HI flame setting. No adjustment in flame height is possible.

Remote Position:

The remote position allows operation of the appliance from a wired wall switch or IFT-RC400 remote controls. The IFT-ECM switch must be in this position to pair the IFT-ECM with the IFT-ACM (if installed), and/or IFT-RC400 remote controls. See the IFT-RC400 installation manual for detailed instructions on pairing the IFT-ECM with the remote controls.

After successfully pairing a IFT-RC400, all installed accessories can be controlled by the IFT-RC400 (see IFT-RC400 user manual). The IFT-ECM has a safety feature that will automatically shut down the fireplace after 9 hours of continuous operation without receiving a command from the IFT-RC400.

The IFT-ECM has a safety feature that will automatically shut down the fireplace after 9 hours of continuous operation in the ON position, except when operated in active thermostat mode.

2. If multiple control options are installed, the IFT-ECM will respond to the last command from the wired wall switch or IFT-RC400. The wired wall switch is NOT available if a Power Vent is used.

3. The Pilot button on the IFT-ECM activates the Cold Climate function of the fireplace. This function lights the pilot flame ONLY to provide enough heat in the firebox to reduce condensation in cool, high humidity ambient conditions. To activate the Cold Climate press and hold the Pilot button for one second and release. The IFT-ECM will flash two green LED blinks, beep twice and light and rectify the pilot flame when pressed to activate. To turn off Cold Climate, press and hold the Pilot button for one second and release. The IFT-ECM will flash one green LED blink, beep once and shut down the pilot flame. If remote controls are paired with the IFT-ECM, this feature can also be activated with the IFT-RC400.

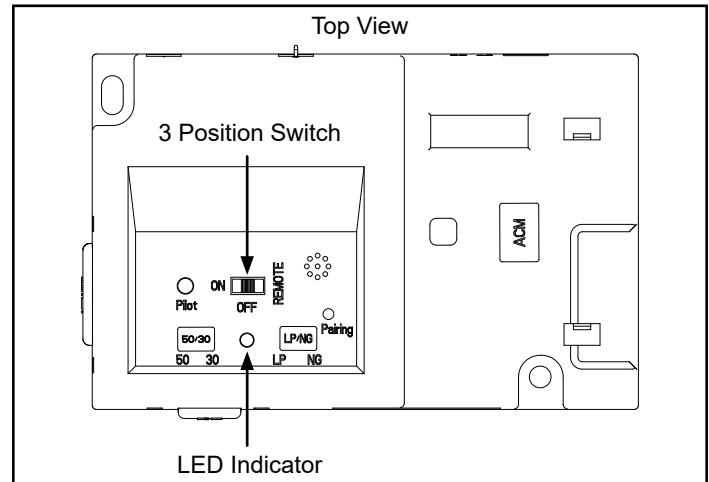



Figure 4.6 - IFT-ECM

! DANGER



Risk of Explosion

DO NOT cycle the ON/OFF/REM selector switch more than one time within a five minute period. Gas may accumulate in firebox. Call a qualified service technician.

4. An IFT-ECM reset is required if the module is in a lock-out condition. When this occurs, the appliance is shut down and the IFT-ECM status indicator LED will be blinking a RED/GREEN error code along with a one-time audible double- beep. If the IFT-ECM is in a lock-out condition, refer to the troubleshooting chart to interpret the error code and take corrective action as required. To reset the IFT-ECM after a lock-out error:

CAUTION! Risk of burns! Appliance surfaces are hot when operating and during cool down. Use care and wear gloves when opening the front and accessing components inside the appliance.

- Be aware the appliance may be HOT, use care in accessing the IFT-ECM.
- Set the IFT-ECM 3-position selector switch to OFF position.
- Wait five (5) minutes to allow possible accumulated gas to clear.
- Set the IFT-ECM 3-position selector switch to ON or REMOTE position. Module will beep once and flash a three GREEN LED code on successful startup.
- If placed in ON position, the appliance will ignite normally if the error condition was corrected.
- If placed in REMOTE position, use the paired IFT-RC400 or wired wall switch to start the appliance; appliance will ignite normally if the error condition was corrected.
- If the IFT-ECM re-enters the lock-out condition after these steps, call your dealer for service.

IntelliFire™ Touch Ignition System

NOTICE: Batteries should not be placed in the battery pack while using the transformer. Remove batteries before using the transformer, and unplug the transformer before installing the batteries. Battery polarity must be correct or module damage will occur.

Appliance ON/OFF:

This model is supplied with a fully functional remote control. This remote controls:

- ON/OFF Functions
- Flame height adjustments
- Thermostat
- Cold Climate Feature
- Fan Speed

Please refer to the instructions included with the remote control for more detailed operating instructions.

L. Frequently Asked Questions - IntelliFire™ Touch Controls (IFT-RC400)

Symptom	Possible Cause	Corrective Action
The appliance does not respond to commands from the remote control display does not light up when screen is touched.	Batteries are depleted.	Verify batteries are new.
	Batteries are incorrectly oriented.	Verify batteries are installed in correct orientation as shown on batteries receptacle.
The display on remote lights up when screen is touched but it does not respond to commands.	Touchscreen has lost calibration.	Touchscreen needs to be re-calibrated. Call dealer to have screen re-calibrated.
	Child Lock is ON.	Check child lock icon located at the top of the remote display. If ON, it will show as a 'locked' symbol. To unlock, remove battery compartment door, locate child lock switch and move to 'unlock' position. Verify child lock icon on screen is now displayed in 'unlock' position.
The remote displays the following message on-screen: No dealer info available	Dealer information not programmed into remote.	Remote will still provide all available functions, and appliance is fully available for use. Call dealer to have them program.
The remote displays the following message on-screen: Call "Dealer Name & Number" to schedule maintenance.	300 hours of use. Appliance is still fully functional.	The appliance has been burning for 300 hours and is due for a regular maintenance. Call dealer to have them perform maintenance.
The room temperature displayed on the remote is either slow or quick to respond while operating in thermostat mode.	Remote is placed at a very short distance or too far away from the appliance.	Try to keep the remote close to the appliance but not directly in front of it. The remote acts as the thermostat.
	Remote is placed in the path of an air draft or vent.	Move the remote away from the direct path of air flow. The remote acts as the thermostat.
	Flame Modulation	The control system is designed to automatically adjust the flame intensity based on the difference between the desired room temperature, and actual temperature. In thermostat mode, the hearth appliance will start in HI flame, but as the actual temperature approaches the desired set temperature on the remote, the flame intensity will automatically decrease. Automatic flame modulation will result in more control of the temperature, and will cause the appliance to cycle OFF/ON less.
The appliance turns OFF the flame after extended periods of operation	9 hour safety shutdown timer	This is normal behavior. The appliance has a safety timer that will automatically turn OFF the flame after nine hours of uninterrupted operation.
The remote displays the following message on-screen: Fan will turn on within 3 minutes	Functioning as intended.	The appliance has a three minute delay timer before the fan is turned ON. This allows the air surrounding the appliance to be heated before being pushed into the room.
The remote displays the following message on-screen: "Replace remote batteries."	Low batteries in remote.	Install new batteries in the remote.
The remote is displaying an incorrect brand.	Remote was programmed incorrectly.	Call dealer to have them program the remote with correct branding. Remote is still fully functional and the appliance is unaffected.
After turning flame ON using remote, the flame does not turn ON immediately and instead a two minute timer is displayed.	Power vent is installed on the appliance.	This is expected behavior and the two minute timer is called a pre-purge timer. The flame will turn ON at the expiration of the timer.
The remote displays the following message on-screen: "Remote Control Communication Error."	No power to appliance.	Verify home circuit breaker is on and master reset is on (if equipped).
	Power outage.	Install new batteries in battery backup.
The remote displays the following message on -screen: Sorry your appliance did not start. Try again by pressing Flame On.	No power to appliance. No gas to appliance. Accumulation of air in gas line from extended period of appliance inactivity. Gas control system failure.	Verify that appliance has power and gas. Verify that the appliance accepts flame ON commands with an audible beep, and successfully turns flame on within 90 seconds. If this failure persists, contact dealer for service.

M. Troubleshooting

With proper installation, operation, and maintenance your gas appliance will provide years of trouble-free service. If you do experience a problem, this troubleshooting guide will assist a qualified service technician in the diagnosis of a problem and the corrective action to be taken. This troubleshooting guide can only be used by a qualified service technician. Contact your dealer to arrange a service call by a qualified service technician.

IntelliFire™ Touch

Error Codes

ECM LED Error Codes	Description
3 Red: 1 Green	IFT-RC400 error message: 'Appliance Safely Disabled', pilot sparks for 90 sec, no flame rectification.
2 Red: 1 Green	IFT-RC400 display: 'Error Pilot Flame', pilot valve solenoid not detected.
2 Red: 2 Green	Sparkling feedback signal error, spark coil failure.
5 Red: 1 Green	IFT-RC400 display: 'Error Power Vent' (if installed).

See Troubleshooting matrix for more detail on Lock-out Error Codes, Possible Causes and Corrective Actions.

Troubleshooting:

Symptom	Possible Cause	Corrective Action
Pilot won't light, module clicks but no spark 90 sec, 3 Red/1 Green Lock out.	Incorrect wiring.	Verify 'S' (White) sense wire and 'I' (orange) ignitor wire are connected to correct terminals on IFT-ECM.
	Loose connections or electrical shorts in wiring.	Verify no loose connections or electrical shorts in wiring from module to pilot assembly. Verify wire insulation is not damaged. Verify wires are not grounding out to chassis, pilot burner, or any other metal object. Replace any damaged wires.
	Ignitor gap is too large.	Verify spark gap is approximately 0.095" (2.41 mm) to 0.135" (3.43 mm).
Pilot won't light, there is no noise or spark.	No AC power, AC/DC adaptor faulty, backup batteries (if being used) depleted, IFT-ECM slider switch in OFF position.	Verify IFT-ECM slider switch is in ON or REM position. Verify AC power available to junction box. Verify AC/DC adaptor is plugged into junction box and ECM. Verify AC/DC adaptor output voltage is between 5.7-6.3 Vdc. If battery pack is used, check battery pack voltage is >4.2 V (if not, replace batteries).
	Shorted or loose connection in system wiring or wiring harness.	Verify system wiring configuration. Remove and reinstall wiring harness that plugs into module. Check continuity of wires in valve wiring harness. Replace any damaged components.
	Poor or no system ground.	Verify black ground wire in valve harness is connected to metal chassis of fireplace.
Pilot won't light, there is no noise or spark, 2 Red/1 Green Lockout.	Pilot solenoid not detected.	Check if valve harness orange wire is connected to pilot solenoid valve. Check pilot solenoid resistance, nominal is 40 ohms. If open or shorted, replace valve. Check valve harness wire continuity, if open replace 6-pin harness.
Pilot won't light, there is no noise or spark, 2 Red/2 Green Lockout.	Spark coil failure.	Replace ECM.

M. Troubleshooting - (Continued)

Symptom	Possible Cause	Corrective Action
Pilot sparks but does not light, after 90 sec, 3 Red/1 Green Lockout	No gas supply.	Verify incoming gas line ball valve is 'Open'. Verify inlet pressure is within requirement for gas type used. Contact gas supplier.
	ECM has poor ground.	Verify wiring, check valve harness black wire is securely grounded to metal chassis.
	Gas valve defective.	Check pilot valve solenoid kick and hold voltages during ignition cycle. Kick V should be >1 V, hold V minimum 0.26 V. If voltages are OK, replace gas valve.
Pilot lights but main burner does not light. Pilot continues to spark for 90 sec then goes into 3 Red/1 Green Lockout.	No flame detected. Flame rectification issue.	Check if white sense lead is securely connected to 'S' terminal of IFT-ECM. Check resistance of sense lead between sense rod tip and connector to IFT-ECM, should be less than 1 ohm - if not, replace pilot assembly. Check system ground, ensure black valve harness wire is securely attached to metal chassis. Check wiring for damage. With system OFF, check resistance between tip of sense rod and pilot hood, should be resistance (>1 M-ohm).
	No flame detected or sense rod contamination.	With glass assembly installed, verify pilot flame is engulfing flame sense rod on pilot assembly. Verify inlet gas pressure is correct for gas type. Polish flame sense rod with fine steel wool to remove any contaminants that may have accumulated.
Pilot lights and rectifies, but main burner does not light.	Main valve solenoid.	Check if green wire in valve harness is connected to green main valve solenoid. Check main valve solenoid resistance, nominal is 60 ohms. If open or shorted, replace valve. Verify valve inlet pressure is correct for gas type.
Pilot and main do not light, ECM goes into 5 Red/1 Green Lockout.	Power Vent (PV) Failure.	Power Vent blower defective - check wiring to IFT-ACM, check if blower is working. Check if PV pressure switch is connected to brown and black wire in 6-pin valve wire harness. Check if pressure switch is closed (shorted) when PV blower is running. Refer to PV troubleshooting instructions.
Appliance lights and runs for a few minutes then shuts down and/or appliance cycle ON and OFF with less than 90 sec of ON time.	Shorted or loose connection in flame detection circuit.	Check if white sense lead is securely connected to 'S' terminal of IFT-ECM. Check resistance of sense lead between sense rod tip and connector to IFT-ECM, should be less than 1 ohm - if not, replace pilot assembly. Check system ground, ensure black valve harness wire is securely attached to metal chassis. Check wiring for damage. With system OFF, check resistance between tip of sense rod and pilot hood, should be resistance (>1 M-ohm).
	Poor flame rectification or contaminated sense rod.	With glass assembly installed, verify pilot flame is engulfing flame sense rod on pilot assembly. Verify inlet gas pressure is correct for gas type. Polish flame sense rod with fine steel wool to remove any contaminants that may have accumulated. Verify no soot deposits are in sense rod to pilot hood gap.
	Logs are set up wrong.	Remove and re-install logs per the log placement instructions.
	Damaged pilot assembly.	Verify the pilot assembly ceramic insulator around the flame sensing rod is not cracked, damaged or loose. Check resistance between tip of sense rod and IFT-ECM connector, should be less than 1 ohm. Replace pilot assembly if damage is detected.

N. Burner, Pilot & Control Compartment

WARNING

Turn off gas before servicing stove. It is recommended that a qualified service technician perform these check-ups at the beginning of each heating season

Keep the control compartment, stones and burner areas surrounding the stones clean by vacuuming or brushing at least twice a year. Make sure the burner porting, pilot air opening and burner air opening are free of obstructions at all times.

Pilot Flame

The flames from the pilot should be visually checked as soon as the heater is installed and periodically during normal operation. The pilot flame must always be present when the stove is in operation, Figure 4.7. The pilot flame has three distinct flames, one engulfing the sensor, one engulfing the thermopile, and the other reaching to the main burner.

Burner

Inspect area around the injector. Remove any lint or foreign material with a brush or vacuum.

Burner Flame

The flames from the burner should be visually checked as soon as the heater is installed and periodically during normal operation. In normal operation, at full rate, and after operating for about 15 to 30 minutes, the flame should be yellow.

NOTE: The type of installation, vent system configuration, and wind effects may cause the flame patterns to vary.

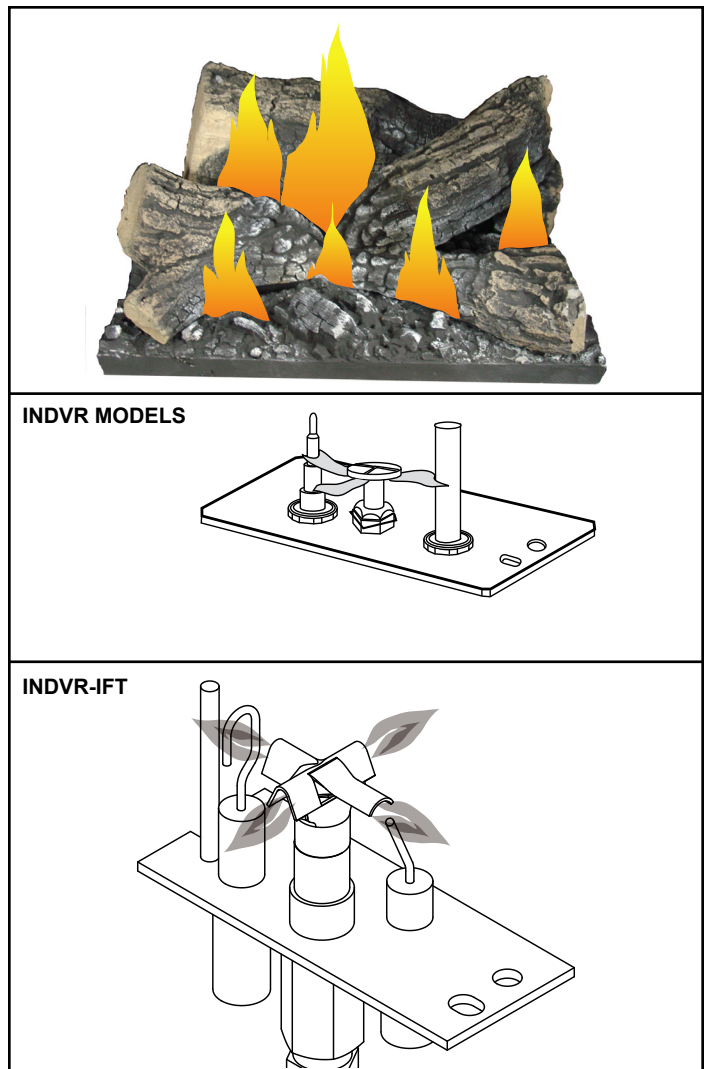

Figure 4.7 - Correct pilot and burner flame appearance.

5 Cleaning and Maintenance

Your Intrepid DV Gas Heater will provide years of service with minimal upkeep. The following procedures will help ensure that your stove continues to function properly.

A. Annual System Inspection

Have the entire heater and venting system inspected annually by a qualified gas technician. Replace any worn or broken parts.

B. Logset & Burner / Cleaning and Inspection

Cleanliness is critical to the proper function of the heater. The logset and burner must all be kept free of dust and unobstructed by debris. Inspect these areas before each use and clean as necessary.

1. Turn the burner OFF and let the heater cool completely before cleaning.
2. Remove the safety barrier and lift the stove front up and then swing the bottom out to disengage it from the heater shell.
3. Carefully remove the glass and frame assembly and place it out of the way on a flat, padded surface such as a counter protected by a towel.
4. Carefully inspect the Logs for damage. Contact your local dealer if any damage is evident.
5. Use a soft bristled brush to sweep dust or debris from the Logs, Pilot and Burner. Use care as the logs are fragile and susceptible to damage.
6. Replace the glass panel and frame assembly.
7. Replace the stove front and safety barrier.

C. Care of Cast Iron

An occasional dusting with a dry rag will help keep the painted surfaces looking new. Use high-temperature stove paints, available through your local dealer, to touch-up areas as needed. Clean areas to be painted with a wire brush and be sure to cover the logs, burner and valve assembly, glass and frame assembly. Apply the paint sparingly; two light coats of paint will give better results than a single heavy coat.

Clean porcelain enamel surfaces with a soft, damp cloth. Do not use abrasive cleaning agents. If necessary, use only a cleaning agent formulated especially for use on porcelain enamel surfaces.



CAUTION

Turn the pilot off before painting. Allow the heater to cool completely before painting.

D. Glass Cleaning and Replacement

It will be necessary to clean the glass periodically. During start-up, condensation, which is normal, forms on the inside of the glass and causes lint, dust and other airborne particles to cling to the glass surface. Also initial paint curing may deposit a slight film on the glass. It is therefore recommended that the glass be cleaned two or three times with a non-ammonia household cleaner and warm water (we recommend gas stove glass cleaner). Allow the glass to cool completely before attempting to clean. To access the glass, remove the front and glass frame, Figures 5.1 and 5.2. After that the glass should be cleaned two or three times during each heating season depending on the circumstances present.

NOTE: Clean glass after first two weeks of operation.

Glass Replacement

Replace glass only with HHT approved parts. Refer to Section 7 "Service Parts List" for correct glass. Remove the front, glass frame and glass panel, Figures 5.1 & 5.2. Use a razor blade to separate the glass and gasket from the frame.

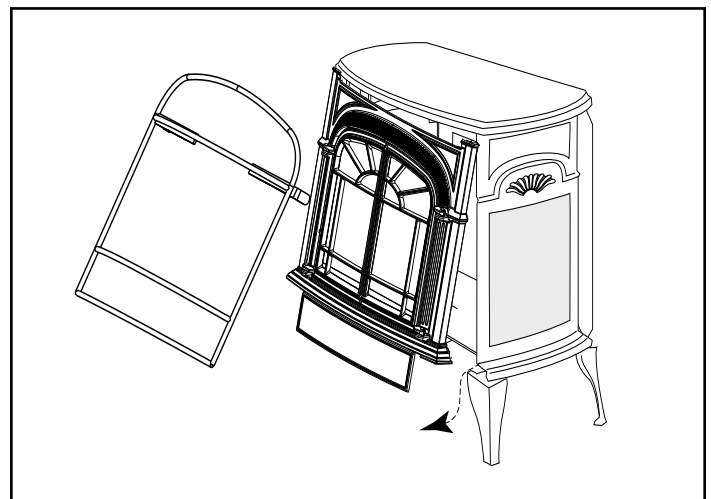

Figure 5.1 - Remove the stove front.

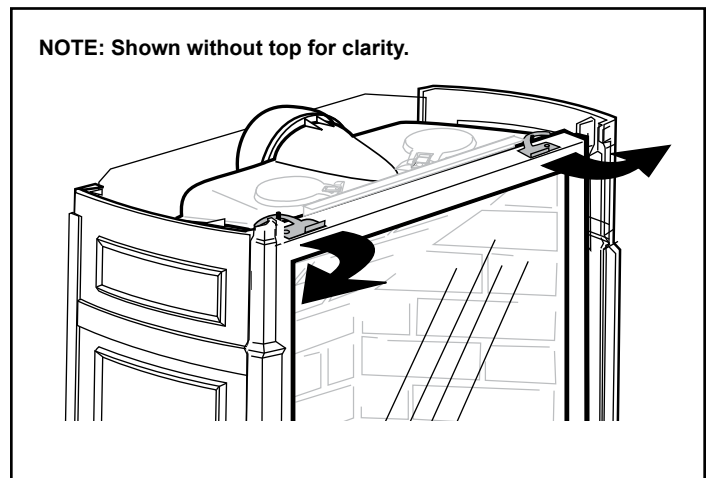

Figure 5.2 - Release the latches to remove the glass frame.

DANGER



**HOT GLASS WILL
CAUSE BURNS.**

**DO NOT TOUCH GLASS
UNTIL COOLED.**

**NEVER ALLOW CHILDREN
TO TOUCH GLASS.**

A barrier designed to reduce the risk of burns from the hot viewing glass is provided with this appliance and must be installed.

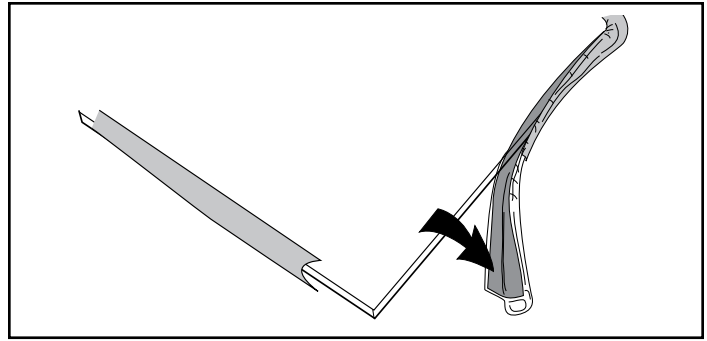

Figure 5.3 - Wrap the gasket material around the outside edge of the glass.

E. Gasket Replacement

The Intrepid DV Gas Heater uses a ‘tadpole’ type gasket to seal between the glass panel and the frame. In time, this gasket can become brittle and compressed and should be replaced. New gasket is available from your dealer.

Shut off the gas supply and allow the stove to cool. Wear safety goggles and a dust mask.

1. Remove the front, glass frame and glass panel, Figures 5.1 & 5.2. To remove the old gasket, use a razor blade to separate the glass and gasket from the frame, and to clean the glass of any remaining cement or bits of gasket. Use a cold chisel if necessary.
2. Determine the correct length of gasket by laying it out around the edge of the glass. Allow an extra 1 - 2" (25-50mm). Mark the spot to be cut. Use a utility knife.
3. Starting on a long edge, remove about 6" of the protective paper strip and apply the flat adhesive face of the gasket around the outside-facing edge of the panel. Continue around the panel, applying about 6" at a time and being careful to not stretch the material. Do not overlap the gasket ends, Figure 5.3.
4. Apply a thin bead of high temperature silicone rubber sealant along the inside corner of the glass frame, all around the perimeter. Place the flat gasketed side of the glass panel back into the steel frame. Pinch the rounded inside-facing gasket material to bulk it up.
5. Replace the glass frame and front panel as previously described.

F. Inspect the Vent System Annually

Have the vent system inspected annually by a qualified technician. Shut off the main gas supply before inspecting the system. Both the inner exhaust pipe and the outer combustion supply pipe must be checked to confirm that they are unblocked and in good condition.

G. Check the Gas Flame Regularly

To ensure that the stove is operating properly, check the flames periodically to confirm they match Figure 5.4. The flames will be blue during the first 15-20 minutes of operation, and will gradually turn to yellow after that.

Do not use your stove if the flame pattern differs from that shown here. Contact your Vermont Castings dealer or a qualified technician for help.

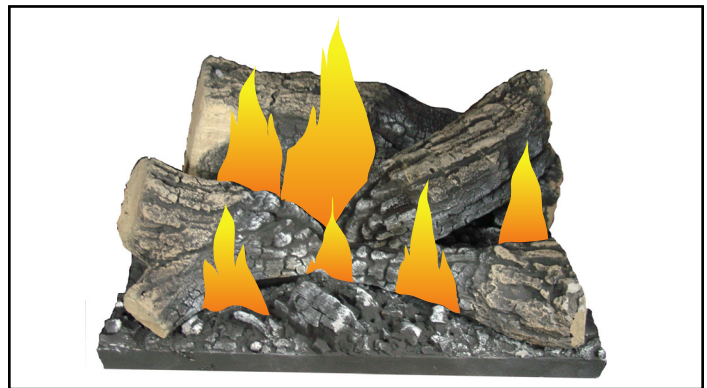

Figure 5.4 - Proper flame appearance

6 Wiring Diagrams

INDVR Models (Millivolt Only)

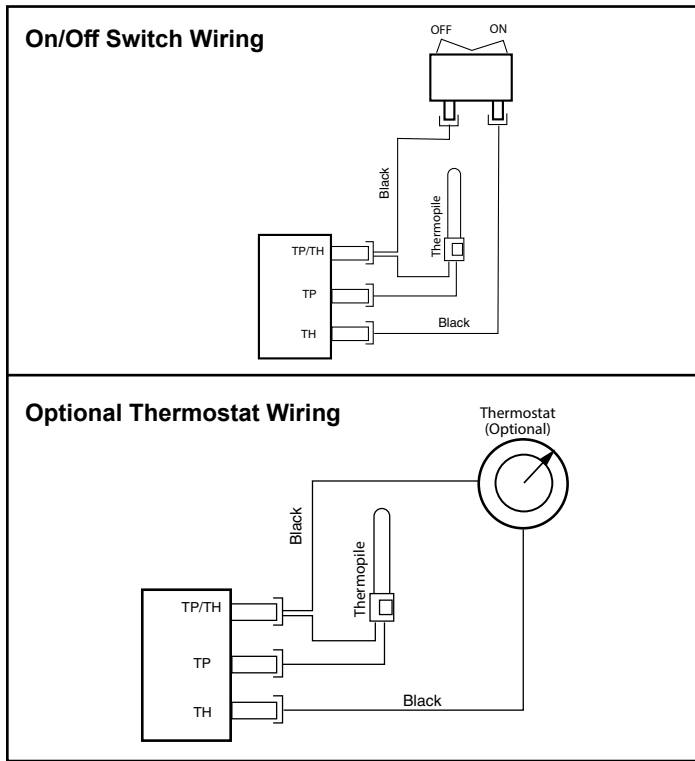

Figure 6.1 - On/off switch and optional thermostat circuit.

NOTE: If any of the original wire, as supplied with the appliance, must be replaced, it must be replaced with type SF-2, 200°C wire or its equivalent.

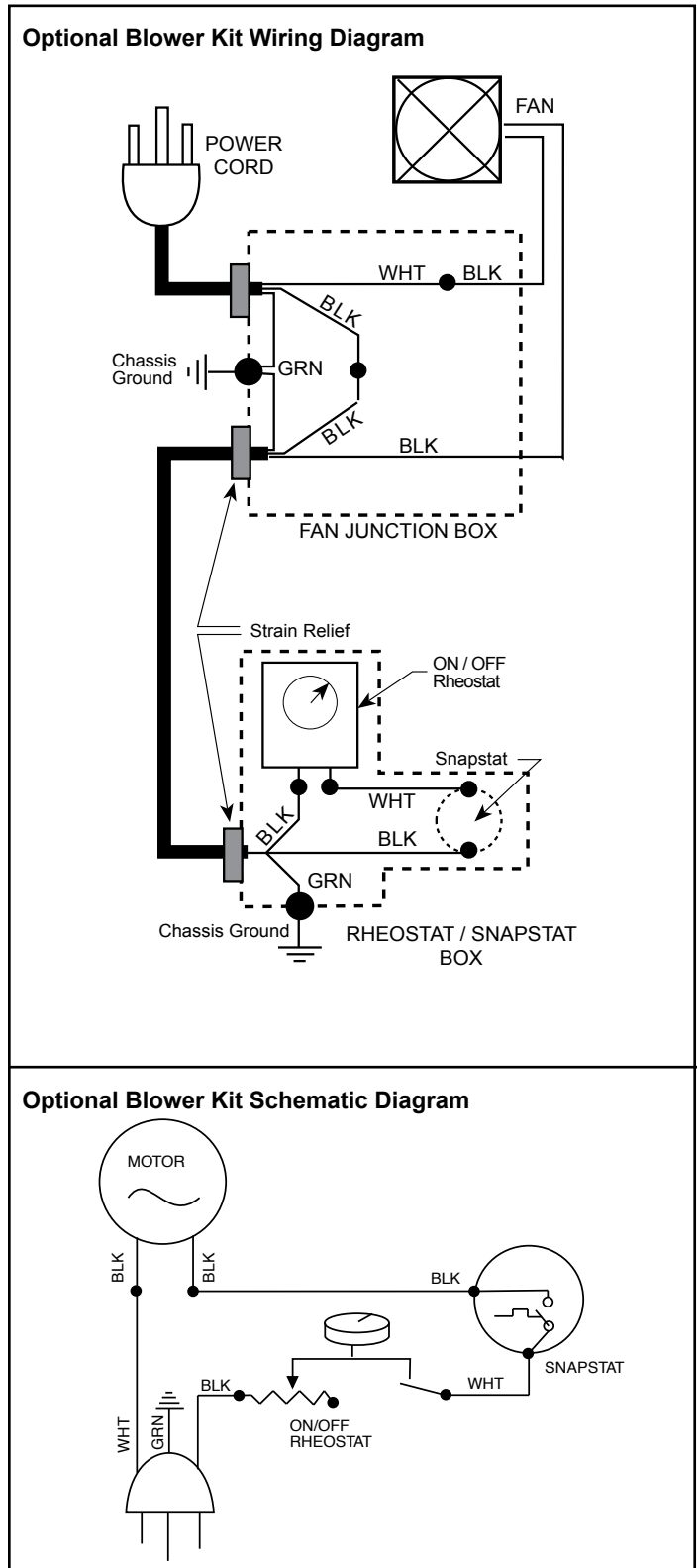

Figure 6.2 - Fan circuit.

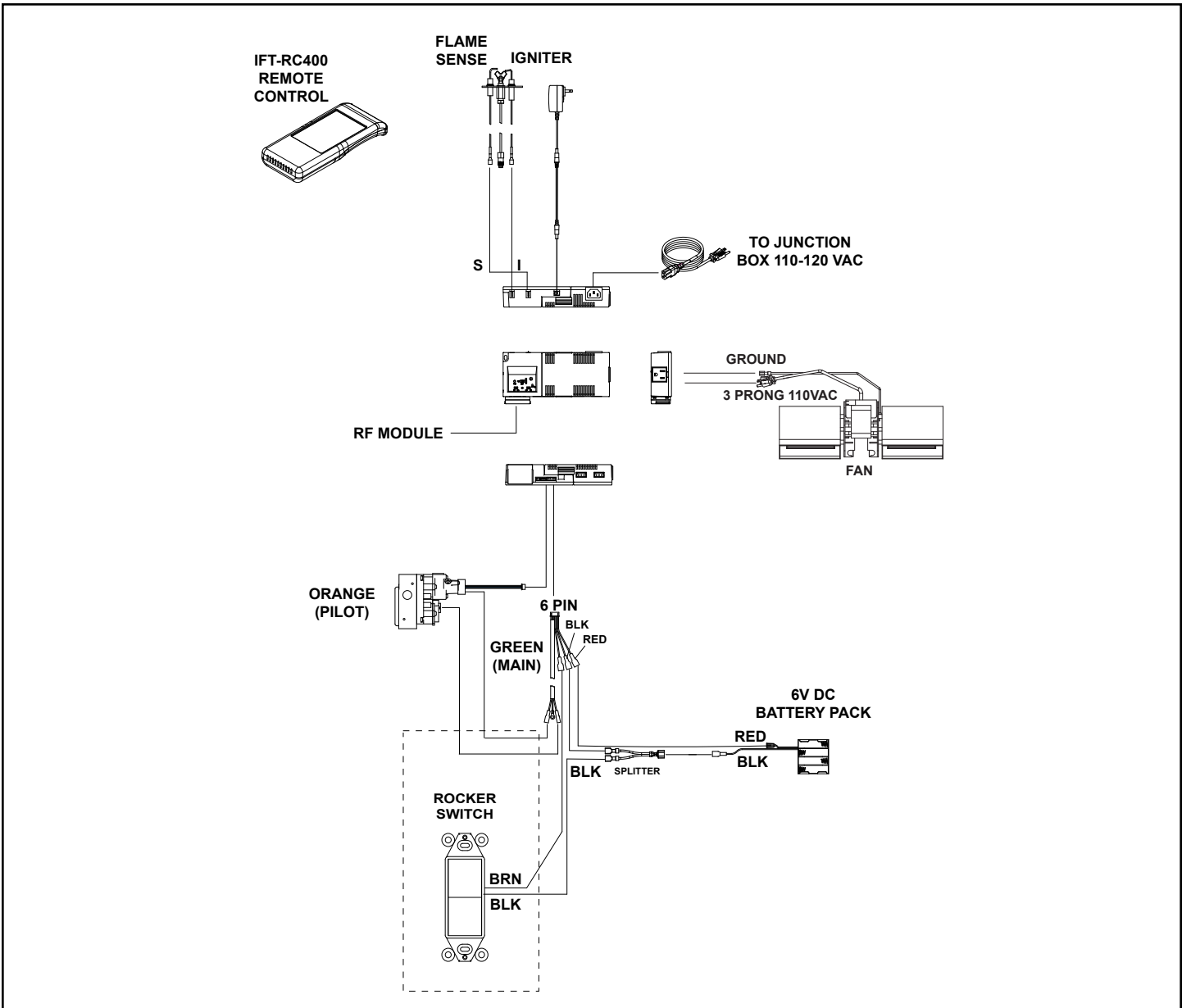

Figure 6.3 - INDV-IFT Wiring Diagram

7 Service Parts List



Service Parts

INTREPID DVR

Beginning Manufacturing Date: NA

Ending Manufacturing Date: Active

Gas Stove

Intrepid Direct Vent/Rear Vent Gas Heater With Standing Pilot Ignition

INDVRCBSB (Classic Black)
INDVRBDSB (Bordeaux)

INDVRBMSB (Majolica Brown) (End Manufacturing Date: Mar 2019)
INDVRBSSB (Biscuit) (End Manufacturing Date: Mar 2019)



IMPORTANT: THIS IS DATED INFORMATION. Parts must be ordered from a dealer or distributor. **Hearth and Home Technologies does not sell directly to consumers.** Provide model number and serial number when requesting service parts from your dealer or distributor.



Stocked at Depot

ITEM	DESCRIPTION	COMMENTS	PART NUMBER	
1	Log Set, Complete		20012552	
1.1	Log, Rear	No longer available, Must order complete assembly	20013111	
1.2	Log, Right		20012549	
1.3	Log, Left		20013112	
1.4	Log, Top		20013113	
2	Burner Assembly		20012906	Y
3	Top	Classic Black	30003930A	
		Biscuit	SRV30004239	
		Bordeaux	30006762A	
		Brown Majolica	SRV30004921	
4	Front, Operable Door	Classic Black	30003931A	
		Biscuit	SRV30004240	
		Bordeaux	30006763A	
		Brown Majolica	SRV30004922	
5	Door, Right	Classic Black	30003933A	
		Biscuit	SRV30004242	
		Bordeaux	30006765A	
		Brown Majolica	SRV30004925	
6	Door, Left	Classic Black	30003932A	
		Biscuit	SRV30004241	
		Bordeaux	30006764A	
		Brown Majolica	SRV30004924	
7	End, Left	Classic Black	30003934A	
		Biscuit	SRV30004237	
		Bordeaux	30006760A	
		Brown Majolica	SRV30004919	
8	End, Right	Classic Black	30003935A	
		Biscuit	SRV30004238	
		Bordeaux	30006761A	
		Brown Majolica	SRV30004920	
9	Leg	Classic Black	1306333A	
		Biscuit	SRV30003182	
		Bordeaux	30006716A	
		Brown Majolica	SRV30004830	
10	Door, Control		30003945A	
11	Hinge, Control Door		1601670	
12	Rear Shroud Assembly		30004132	

Additional service parts on following page

IMPORTANT: THIS IS DATED INFORMATION. Parts must be ordered from a dealer or distributor. **Hearth and Home Technologies does not sell directly to consumers.** Provide model number and serial number when requesting service parts from your dealer or distributor.



Stocked at Depot

ITEM	DESCRIPTION	COMMENTS	PART NUMBER	
13	Clip, Rear Shroud		30004002	
14	Glass Frame		30004068	
15	Glass		30004067	Y
16	Gasket, Glass	Medium Knit, 10 FT	1203702K	
17	Restrictor Plate		SRV4604-114	
18	Heat Shield Top		30004128	
19	Collar, Duravent		30004131	
20	Starter, 4 Inch		30004130	Y
21	Fan Cover Shroud		30004014	
22	Valve, Nova SIT 820.852		20012218	Y
23.1	Pilot Assembly, 3 Way	N/DV RN 0.199.706	SRV10002264	Y
		N/DV RP 0.199.703	SRV10002265	Y
23.2	Pilot, PSE	NA175	20001115A	Y
		LP175	20001116A	Y
24	Thermocouple		SRV24D0808	Y
25	Electrode Ignitor w/Cable SIT24		10001297	Y
26	Thermopile, 18" RS		SRV26D0566	Y
27	Tubing, Pilot w/Fitting 1/8 x 24"		26D0665	Y
28	Pilot Orifice #62, Top Convertible	NG	529-512	
	Pilot Orifice #35, Top Convertible	LP	SRV200-2630	Y
29	Orifice Hood, #49/.073	NG	SRV4604-317	
	Orifice Hood, #56/.0465	LP	30000336	
30	Ignitor Piezo w/Nut, SIT		057958A	Y
31	Manifold Assembly		20012553	Y
32	Air Shutter Assembly		20012517	
33	Wiring Harness		10002582	Y
34	Trim On/Off Switch		30000874	Y
35	Gasket, Control Plate		30004200	
36	Gasket, HE Door		1203687A	Y
37	Gasket, Flue Collar		30004021	Y
38	Gasket Cement		1206122	Y
	Magnet, Door	Use common super glue or silicone to attach	1408818	
39	Knob Extension, Hi/Lo		43D0095A	
40	Knob Extension, On/Off		43D0094A	
41	Tie Bracket Assembly		20012514	
42	Right Burner Support Assembly		20012909K	

Additional service parts on following page

IMPORTANT: THIS IS DATED INFORMATION. Parts must be ordered from a dealer or distributor. **Hearth and Home Technologies does not sell directly to consumers.** Provide model number and serial number when requesting service parts from your dealer or distributor.



**Stocked
at Depot**

ITEM	DESCRIPTION	COMMENTS	PART NUMBER	
43	Safety Barrier		30007255	
44	Zero Clearance Sleeve	Qty 2 req	54623	
	Touch-Up Paint	Classic Black	3-42-19905	
		Bordeaux	0001341	
		Biscuit	0001277	
		Majolica	0001270	
	Fan Kit		FK20-VC	Y
	Fan (Only)		SRV3-21-55416	
	Cord, Fan Power		SRV8320-000	Y
	Flexline	Black	20H1011	
	Finish Bag		30007265K	
	Warming Shelf Kit	Classic Black	0000098	
		Bordeaux	0001380	
		Biscuit	0001376	
		Majolica	0001373	
	Shelf	Classic Black	1302254A	
		Bordeaux	SRV30006720	
		Biscuit	SRV30003214	
		Majolica	SRV30004831	
	Shelf Bracket	Classic Black	1302272A	
		Bordeaux	SRV30006721	
		Biscuit	SRV30003215	
		Majolica	SRV30004832	
Conversion Kits				
	Conversion Kit, NG to LP		LPK-INDVR-SP	Y
	Conversion Kit, LP to NG		20012910	Y

Gas Stove

Beginning Manufacturing Date: Feb 2019
Ending Manufacturing Date: Active

Intrepid Direct Vent/Rear Vent Gas Heater w/IFT Controls

INDVR-IFT-CB (Classic Black)

INDVR-IFT-BD (Bordeaux)

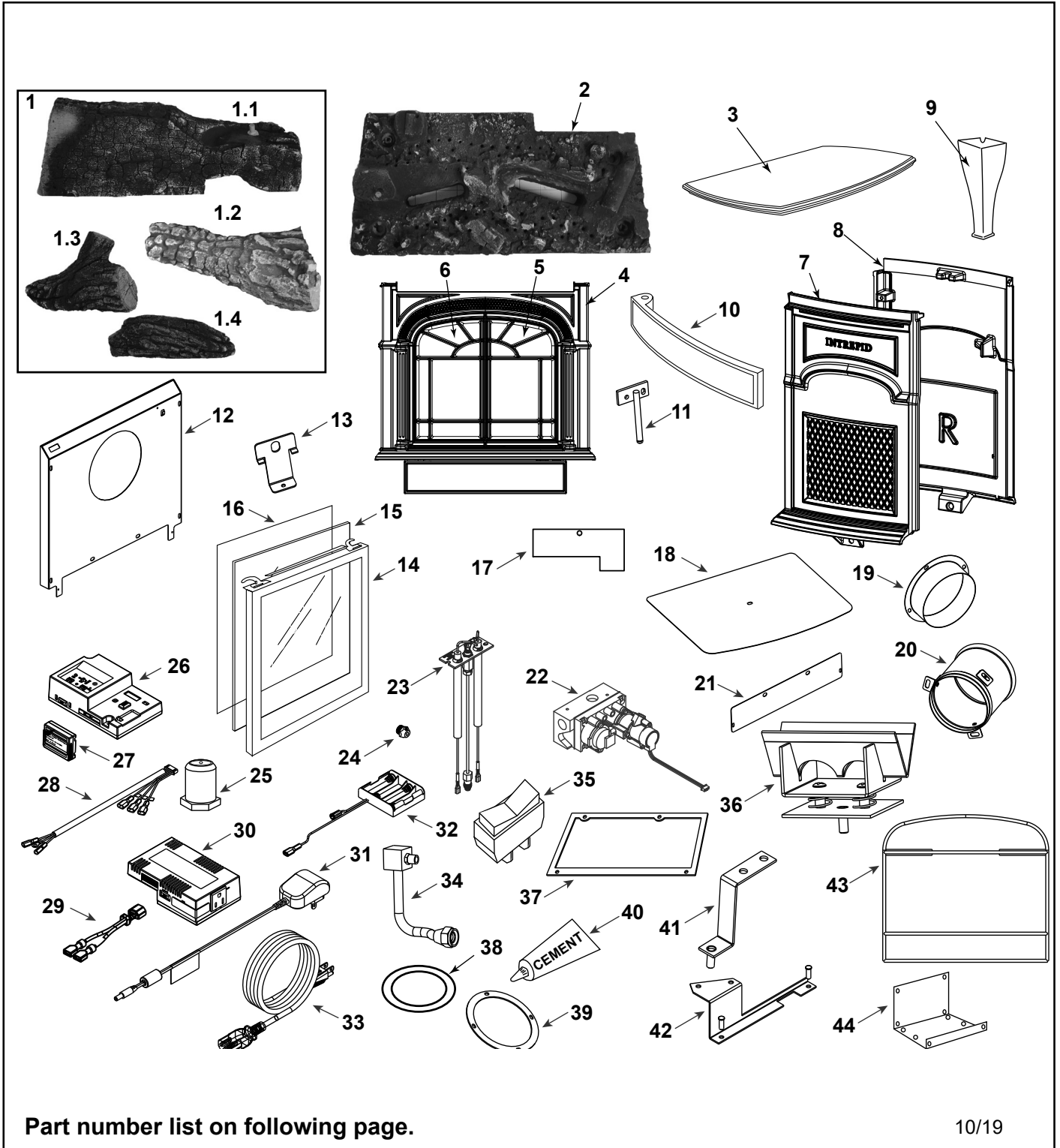

Part number list on following page.

10/19

IMPORTANT: THIS IS DATED INFORMATION. Parts must be ordered from a dealer or distributor. **Hearth and Home Technologies does not sell directly to consumers.** Provide model number and serial number when requesting service parts from your dealer or distributor.



Stocked at Depot

ITEM	DESCRIPTION	COMMENTS	PART NUMBER	
1	Log Set, Complete		20012552	
1.1	Log, Rear	No longer available, Must order complete assembly	20013111	
1.2	Log, Right		20012549	
1.3	Log, Left		20013112	
1.4	Log, Top		20013113	
2	Ember Bed Assembly		20012906	Y
3	Top	Classic Black	30003930A	
		Bordeaux	30006762A	
4	Front, Operable Door	Classic Black	30003931A	
		Bordeaux	30006763A	
5	Door, Right	Classic Black	30003933A	
		Bordeaux	30006765A	
6	Door, Left	Classic Black	30003932A	
		Bordeaux	30006764A	
7	End, Left	Classic Black	30003934A	
		Bordeaux	30006760A	
8	End, Right	Classic Black	30003935A	
		Bordeaux	30006761A	
9	Leg	Classic Black	1306333A	
		Bordeaux	30006716A	
10	Door, Control		30003945A	
11	Hinge, Control Door		1601670	
12	Rear Shroud Assembly		SRV30007473	
13	Clip, Rear Shroud		30004002A	
14	Glass Frame		30004068	
15	Glass		30004067	Y
16	Gasket, Glass	Medium Knit, 10 FT	1203702K	
17	Restrictor Plate		SRV4604-114	
18	Heat Shield Top		30004128	
19	Collar, Duravent		30004131	
20	Starter, 4 Inch		30004130	Y
21	Fan Cover Shroud		30004014	
22	Valve	NG	2166-302	Y
		Propane	2166-303	Y
23	Pilot Assembly	NG	SRV4602-300	Y
	Pilot Orifice	NG	SRV593-528	Y
		Propane	SRV4602-301	Y
24	Orifice Hood, #49/.073	NG	SRV4604-317	
25	Orifice Hood, #56/.0465	LP	30000336	

Additional service parts on following page

IMPORTANT: THIS IS DATED INFORMATION. Parts must be ordered from a dealer or distributor. **Hearth and Home Technologies does not sell directly to consumers.** Provide model number and serial number when requesting service parts from your dealer or distributor.



Stocked at Depot

ITEM	DESCRIPTION	COMMENTS	PART NUMBER	
26	Control Module		2326-130	Y
27	Module, RF		2326-120	Y
28	Wiring Harness, 6 Pin		SRV2326-132	Y
29	Jumper Wire		SRV2187-198	Y
30	Module, AC		2326-150	Y
31	Transformer, 6 Volt		SRV2326-131	Y
32	Battery Pack**		SRV2326-134	Y
33	Cable, Module AC		SRV2326-152	Y
34	Manifold Assembly		20012553	Y
35	Trim On/Off Switch		30000874	Y
36	Air Shutter Assembly		20012517	
37	Gasket, Control Plate		30004200	
38	Gasket, HE Door		1203687A	Y
39	Gasket, Flue Collar		30004021	Y
40	Gasket Cement		1206122	Y
	Magnet, Door (Use common super glue or silicone to attach)		1408818	
41	Tie Bracket Assembly		20012514	
42	Right Burner Support Assembly		20012909K	
43	Safety Barrier		30007255	
44	Zero Clearance Sleeve	Qty 2 req	54623	Y
	Touch-Up Paint	Classic Black	3-42-19905	
		Bordeaux	0001341	
	Fan Kit		FK20-VC	Y
	Fan (Only)		3-2155416	
	Cord, Fan Power		SRV8320-000	Y
	Flexline	Black	20H1011	
	Finish Bag		SRV30007475	
	RC400 Remote		SRV2326-110	Y
	Warming Shelf Kit	Classic Black	0000098	
		Bordeaux	0001380	
	Shelf	Classic Black	1302254A	
		Bordeaux	SRV30006720	
	Shelf Bracket	Classic Black	1302272A	
		Bordeaux	SRV30006721	
Conversion Kits				
	Conversion Kit	NG to Propane	SRV30007476	Y
		Propane to NG	SRV30007477	Y
	Regulator	NG	NGK-DXV-50	Y
		Propane	SRVLPK-DXV-50	Y

**Fuse for battery pack can be sourced locally, not a warranty item. Specs are 250v, 3A fuse, 3/4" long

8 Optional Accessories

GFK-160A Fan Kit - INDVR Series

The GFK-160A fan helps distribute heated air from within the firebox out into the room. The fan is controlled by a snapstat that turns power on and off as the firebox temperature rises above and falls below a preset temperature. A rheostat provides for variable fan speeds. Used with standard millivolt models.

Remote Controls - INDVR

The remote control allows you to turn the heater on or off from anywhere in the room. Refer to Page 54 for wiring diagrams. These remote controls are for use with standard millivolt models.

ON/OFF Remotes

RCB,RCMT

ON/OFF Thermostat Remote

TSST, RCST

Warming Shelf

Warming shelves add versatility to your stove; they can be used to keep foods warm at mealtime.

Model Color

1560	Classic Black
1553	Brown Majolica
1555	Biscuit
1571	Bordeaux

Shelf Installation

1. Attach the shelf loosely to the stove, leaving the screws loose enough to allow final adjustments.
2. Position the shelf and adjust the brackets so the shelf fits correctly.
3. Tighten the screws.

Refer to the instructions included with each warming shelf for complete installation procedures.

9 Warranty Policy

Hearth & Home Technologies LLC LIMITED LIFETIME WARRANTY

Hearth & Home Technologies LLC (“HHT”) extends the following warranty for HHT gas, wood, pellet and electric hearth appliances (each a “Product” and collectively, the “Product(s)”) and certain component parts set forth in the table below (“Component Part(s)”) that are purchased from a HHT authorized dealer or distributor.

WARRANTY COVERAGE:

HHT warrants that the Products and their Component Parts will be free from defects in materials and workmanship for the applicable period of Warranty coverage set forth in the table below (“Warranty Period”). If a Product or Component Parts are found to be defective in materials or workmanship during the applicable Warranty Period, HHT will, at its option, repair the applicable Component Part(s), replace the applicable Component Part(s), or refund the purchase price of the applicable Product(s). The maximum amount recoverable under this Warranty is limited to the purchase price of the Product. This Warranty is transferable from the original purchaser to subsequent owners, but the Warranty Period will not be extended in duration or expanded in coverage for any such transfer. This Warranty is subject to conditions, exclusions, and limitations as described below.

WARRANTY PERIOD:

Warranty coverage begins at the date of installation. In the case of new home constructions, Warranty coverage begins on the date of first occupancy of the dwelling or six months after the sale of the Product(s) by an independent, authorized HHT dealer or distributor, whichever occurs earlier. However, the Warranty coverage shall commence no later than 24 months following the date of Product shipment from HHT, regardless of the installation or occupancy date.

The term “Lifetime” in the table below is defined as: 20 years from the beginning date of warranty coverage for gas appliances, and 10 years from the beginning date of warranty coverage for wood and pellet appliances. These time periods reflect the minimum expected useful lives of the designated Component Parts under normal operating conditions.

Warranty Period		HHT Manufactured Appliances and Venting						Component Parts Covered by this Warranty
Component Parts	Labor	Gas	Pellet	Wood	Electric	Venting		
1 Year		X	X	X		X	All parts including handles, external enameled components and other material except as covered by Warranty Conditions, Warranty Exclusions, and Warranty Limitations listed	
2 Years					X		All parts except as covered by Warranty Conditions, Warranty Exclusions, and Warranty Limitations listed	
2 years			X	X			Igniters, Auger Motors, Electronic Components, and Glass	
		X					Electrical components limited to modules, remotes/wall switches, valves, pilots, blowers, junction boxes, wire harnesses, transformers and lights (excluding light bulbs)	
		X		X			Molded Refractory Panels, Glass Liners	
3 years			X				Firepots, burnpots, mechanical feeders/auger assemblies	
5 years	1 year	X					Vent Free Burners, Vent Free Logs	
			X	X			Castings, Medallions and Baffles	
6 years	3 years			X			Catalysts	
7 years	3 years		X	X			Manifold tubes, HHT Chimney and Terminations	
10 years	1 year	X					Burners, logs and refractory	
Limited Lifetime	3 years	X	X	X			Firebox and heat exchanger, FlexBurn® System (engine, inner cover, access cover and fireback)	
1 Year	None	X	X	X	X	X	All purchased replacement parts	

WARRANTY CONDITIONS:

- Because HHT cannot control the quality of any Products sold by unauthorized sellers, this Warranty only covers Products that are purchased through an HHT authorized dealer or distributor unless otherwise prohibited by law; a list of HHT authorized dealers is available on the HHT branded websites.
- This Warranty is only valid while the applicable Product remains at the site of original installation.
- This Warranty is only valid in the country in which the HHT authorized dealer or distributor that sold the applicable Product is authorized to sell applicable Product.
- Contact your installing distributor or dealer for Warranty service. If the installing dealer or distributor is unable to provide necessary parts, contact the nearest HHT authorized dealer or supplier. Additional service fees may apply if you are seeking Warranty service from a dealer other than the dealer from whom you originally purchased the applicable Product.
- No HHT consumer should bear cost of warranty service or costs incurred while servicing warranty claims (i.e., travel, gas, or mileage) when the service is performed within the terms of this Warranty. Check with your dealer or distributor in advance for any costs to you when arranging a warranty call. Travel and shipping charges for parts are not covered by this Warranty.

WARRANTY EXCLUSIONS:

This Warranty does not cover the following:

- Changes in surface finishes as a result of normal use. As a heating appliance, some changes in color of interior and exterior surface finishes may occur. This is not a flaw and is not covered under the Warranty.
- Damage to printed, plated, or enameled surfaces caused by fingerprints, accidents, misuse, scratches, melted items or other external sources and residues left on the plated surfaces from the use of abrasive cleaners or polishes.
- Repair or replacement of parts that are subject to normal wear and tear during the Warranty Period are not covered. These parts include: paint, wood and pellet gaskets, firebricks, grates, flame guides, batteries and the discoloration of glass.
- Minor expansion, contraction, or movement of certain parts causing noise. These conditions are normal and complaints related to this noise are not covered by this Warranty.
- Damages resulting from: (1) failure to install, operate, or maintain the applicable Product in accordance with the installation instructions, operating instructions, and listing agent identification label furnished with the applicable Product; (2) failure to install the applicable Product in accordance with local building codes; (3) shipping or improper handling; (4) improper operation, abuse, misuse, continued operation with damaged, corroded or failed components, accident, or improperly/incorrectly performed repairs; (5) environmental conditions, inadequate ventilation, negative pressure, or drafting caused by tightly sealed constructions, insufficient make-up air supply, or handling devices such as exhaust fans or forced air furnaces or other such causes; (6) use of fuels other than those specified in the operation instructions; (7) installation or use of components not supplied with the applicable Product or any other components not expressly authorized and approved by HHT; (8) modification of the appliance not expressly authorized and approved by HHT in writing; and/or (9) interruptions or fluctuations of electrical power supply to the applicable Product.
- Non-HHT venting components, hearth connections or other accessories used in conjunction with the applicable Product.
- Any part of a pre-existing fireplace system in which an insert or a decorative gas applicable Product is installed.
- HHT's obligation under this Warranty does not extend to the Product's capability to heat the desired space. Information is provided to assist the consumer and the dealer in selecting the proper Product for the application. Consideration must be given to the Product location and configuration, environmental conditions, insulation and air tightness of the structure.

This warranty is void if:

- The applicable Product has been over-fired, operated in atmospheres contaminated by chlorine, fluorine, or other damaging chemicals. Over-firing can be identified by, but not limited to, warped plates or tubes, deformation/warping of interior cast iron structure or components, rust colored cast iron, bubbling, cracking and discoloration of steel or enamel finishes.
- The applicable Product is subjected to prolonged periods of dampness or condensation.
- There is any damage to the applicable Product due to water or weather damage which is the result of, but not limited to, improper chimney or venting installation.

LIMITATIONS OF REMEDIES AND LIABILITY:

- **EXCEPT TO THE EXTENT PROVIDED BY LAW, HHT MAKES NO EXPRESS WARRANTIES OTHER THAN THE WARRANTY SPECIFIED HEREIN. The owner's exclusive remedy and HHT's sole obligation under this Warranty or in contract, tort or otherwise, shall be limited to replacement of the Component Part(s), repair of the Component Part(s), or refund of the original purchase price of the applicable Product(s), as specified above; provided, however, that (i) if HHT is unable to provide replacement of the Component Part(s) and repair of the Component Part(s) is not commercially practicable or cannot be timely made, or (ii) the customer is willing to accept a refund of the purchase price of the applicable Product(s), HHT may discharge all such obligations by refunding the purchase price of the applicable Product. In no event will HHT be liable for any incidental or consequential damages caused by defects in the applicable Product. Some States do not allow the exclusion or limitation of incidental or consequential damages, so the above limitation or exclusion may not apply to you. This Warranty gives you specific legal rights and you may also have other rights which vary from State to State. THE DURATION OF ANY IMPLIED WARRANTY IS LIMITED TO DURATION OF THE EXPRESSED WARRANTY SPECIFIED ABOVE FOR THE APPLICABLE PRODUCT. Some States do not allow limitations on how long an implied warranty lasts, so the above limitation may not apply to you.**

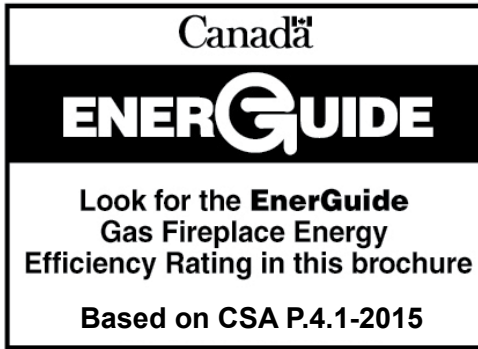

EFFICIENCY RATINGS

MODEL	ENERGUIDE RATINGS STOVE EFFICIENCY PERCENTAGE	D.O.E. (AFUE PERCENTAGE)
INDVR Series	64.0	76.5
INDVR-IFT Series	64.0	76.5



We recommend that our gas hearth products be installed and serviced by professionals who are certified in the U.S. by the National Fireplace Institute® (NFI) as NFI Gas Specialists.



352 Mountain House Road • Halifax, PA 17032
www.vermontcastings.com