

ACTIVE™

1800 PSI Electric Pressure Washer

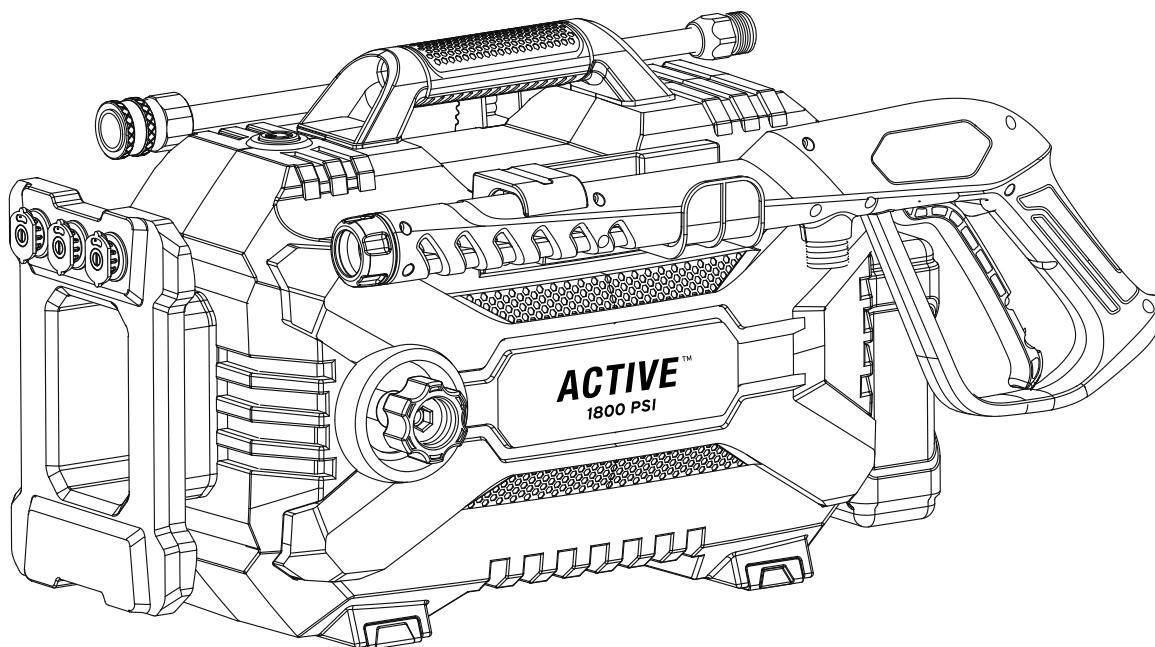

Instruction Manual

Congratulations on the purchase of your new ACTIVE™ pressure washer. In order to ensure you have the best possible experience, please read through the following instructions. If you require any help, please contact the customer service department at:

1-844-777-4555

Contact us for assistance; we're here to help.



Model no.VE52

Version no. 00

Table of Contents

1. IMPORTANT PRECAUTIONS.....	3
1.1 DEFINITIONS	3
1.2 SAFETY WARNINGS.....	3
1.3 INTENDED APPLICATION	5
2. SAFETY FEATURES AND ELECTRICAL INFORMATION	5
2.1 EXTENSION CORDS	5
3. EXPLODED VIEW.....	6
4. PARTS LIST	6
5. ASSEMBLY INSTRUCTIONS	7
5.1 SURFACE PREPARATION.....	7
5.2 WATER SUPPLY (COLD WATER ONLY)	7
5.3 SAFETY ADVICE	7
5.4 ASSEMBLY STEPS	7
6. OPERATING INSTRUCTIONS	11
6.1 WORKING WITH FOAM BLASTER	11
6.2 SHUTTING DOWN AND CLEANING UP	12
6.3 TAKING BREAKS.....	12
6.4 WARNINGS	12
7. WINTERIZING AND LONG-TERM STORAGE.....	13
7.1 OPTIMUM WINTERIZING PROCEDURE.....	13
7.2 QUICK WINTERIZING PROCEDURE	13
8. CLEANING AND MAINTENANCE	14
8.1 CONNECTIONS	14
8.2 CLEANING THE NOZZLE	14
8.3 WATER FILTER SCREEN	14
9. TECHNICAL SPECIFICATIONS.....	14
10. TROUBLESHOOTING	15
11. WARRANTY	17

1. IMPORTANT PRECAUTIONS

IMPORTANT, RETAIN FOR FUTURE REFERENCE AND READ CAREFULLY!

Do not attempt to install or operate this device until you have read the safety instructions in this manual. Safety items throughout this manual are labelled with **Danger**, **Warning**, or **Caution** depending on the risk type.

Failure to follow or comply with the instruction manual in product set-up, usage or storage will void the warranty.

1.1 Definitions

 This is the safety alert symbol. It is used to alert you to potential personal injury hazards. Obey all safety messages that follow this symbol to avoid possible injury or death.

DANGER

Indicates an imminently hazardous situation which, if not avoided, will result in death or serious injury.

WARNING

Indicates a potentially hazardous situation which, if not avoided, could result in death or serious injury.

CAUTION

Indicates a potentially hazardous situation which, if not avoided, could result in minor or moderate injury.



IMPORTANT

Installation, operation, or maintenance information which is important but not hazard-related.

1.2 Safety Warnings

DANGER

To reduce the risk of fire, electric shock, explosion or injury to people, read the following:

- This product is intended for domestic outdoor use only.
- The water spray must never be directed towards any electric wiring, devices, or directly towards the pressure washer itself, or fatal electric shock may occur. 
- The pressure washer should not be used in areas where gas vapours may be present. An electric spark could cause an explosion or fire.
- **Risk of explosion.** When a combustible liquid is sprayed, there can be danger of fire or explosion, especially in a closed area. Therefore, do not spray flammable liquids. Do not use acids and solvents with this product either. These products can cause physical injuries to the operator and irreversible damage to the device.
- **Risk of electric shock.** Inspect the cord before using the device — do not use it if the cord is damaged.
- **Risk of injury.** Do not direct the water flow at people. The high-pressure jet can be dangerous if misused, and therefore must not be directed at people, animals, electrical devices or the unit itself. 
- This device is capable of producing high pressure as rated in the **Technical Specifications**. To avoid rupture and injury, do not operate this machine with components rated less than the unit itself (including but not limited to spray guns, hose, and hose connections).

4 Important Precautions

1. IMPORTANT PRECAUTIONS (CONT.)

1.2 Safety Warnings (cont.)

WARNING — INJECTION HAZARD

- Equipment can cause serious injury if the spray penetrates the skin. Do not point the gun at anyone or any part of the body. In case of penetration, seek medical aid immediately.

CAUTION — DETERGENTS

- This device has been designed for use with detergents that are specifically approved for pressure washer use. The use of other cleaning detergents may affect the operation of the device and void the warranty.

CAUTION — SPRAY GUN

- The spray gun kicks back, so hold it with both hands. The trigger gun safety lock prevents the trigger from being engaged accidentally. However, the safety feature DOES NOT lock the trigger in the **ON** position.

CAUTION — WATER CONNECTIONS

- For use with fresh and clean water only. Do not use this product with other liquids.
- The water supply system must be protected against backflow.
- Never use this product with water contaminated with solvents (e.g. paint thinners, gasoline, oil, etc.).
- Always prevent debris from being drawn into the product by using a clean water source and an additional water filter, if required.
- If this device is connected to a potable water system, the system must be protected against backflow.
- Suitable water temperature: from 5 to 40 °C (41 to 104 °F).

CAUTION — USE

- Learn how to stop the device and release the pressure quickly. Familiarize yourself with the controls.
- Keep all connections dry and off the ground.
- Avoid accidental starts. Shut power **OFF** before connecting or disconnecting the power cord.
- Never carry the pressure washer by the cord.
- Do not pull on the cord to disconnect from the outlet.
- To allow for free air circulation, the pressure washer should not be covered during operation.
- Do not operate the product when tired or under the influence of alcohol or drugs.
- Do not stand on unstable surfaces. Stand with both feet balanced at all times.
- Keep the operating area clear of people and pets.

IMPORTANT — MAINTENANCE

- Any assembly, use or maintenance of the product must be carried out by adults only.
- Follow the maintenance instructions specified in the manual.
- If replacement of the power plug or cord is needed, use only identical replacement parts.
- Repairing and replacing parts should be done by a certified technician.
- Before servicing, cleaning or removal of any parts, shut the power **OFF** and release the pressure.

IMPORTANT — GROUNDING









- In a double-insulated product, two systems of insulation are provided instead of grounding. No grounding is provided on a double-insulated product, nor should a means for grounding be added to the product. Servicing a double-insulated product requires extreme care and knowledge of the system, and should be done only by qualified service personnel. Replacement parts of a double-insulated product must be identical to the parts they replace. A double-insulated product is marked with the words “DOUBLE INSULATION” or “DOUBLE INSULATED”. The symbol  may also be marked on the product.

1. IMPORTANT PRECAUTIONS (CONT.)

1.3 Intended Application

This product is designed for specific residential applications. Do not modify or use this product for any application other than the one it was designed for. This equipment was not designed for industrial use. Please refer to the icons below for suggested applications. For questions regarding other uses, please refer to our website at www.active-jobsite.com or call us at 1-844-777-4555.

▶ IMPORTANT — APPLICATIONS

 STAIRS	 LAWN EQUIPMENT	 VEHICLE
 FENCING	 DECK OR PATIO	 GARAGE FLOOR
 DRIVEWAY	 SIDING	

2.1 Extension Cords

If possible, do not use extension cords with this product. However, if you must use one, observe all warnings and instructions listed below:

CAUTION — USE A SUFFICIENT GAUGE

- Maximum cable length: 50' (15 m). Only use 14 AWG rated extension cords.
- Only use extension cords that are intended for outdoor use. These extension cords are identified by a marking that reads "Acceptable for use with outdoor appliances; store indoors while not in use."
- Only use extension cords that have an electrical rating not less than the rating of the product (15 A).
- Do not use damaged extension cords. Examine the extension cord before using and replace it if damaged. Do not abuse extension cords and do not pull on any cord to disconnect the device.
- Keep cord away from heat and sharp edges.
- Always disconnect the extension cord from the power outlet before disconnecting the extension cord from the product.
- To reduce the risk of electric shock, keep all connections dry and off the ground. Do not touch the plug with wet hands.

2. SAFETY FEATURES AND ELECTRICAL INFORMATION

The pressure washer is equipped with a stop device that senses when the trigger on the spray gun is released. It will open the power circuit to the motor and cause the pressure washer motor to stop. The motor will start again when the trigger is pulled.

WARNING

- The pressure washer is also equipped with a main power **ON/OFF** switch. It should always be moved to the **OFF** position when the pressure washer is not being used to prevent possible injury or damage.

6 Exploded View / Parts List

3. EXPLODED VIEW

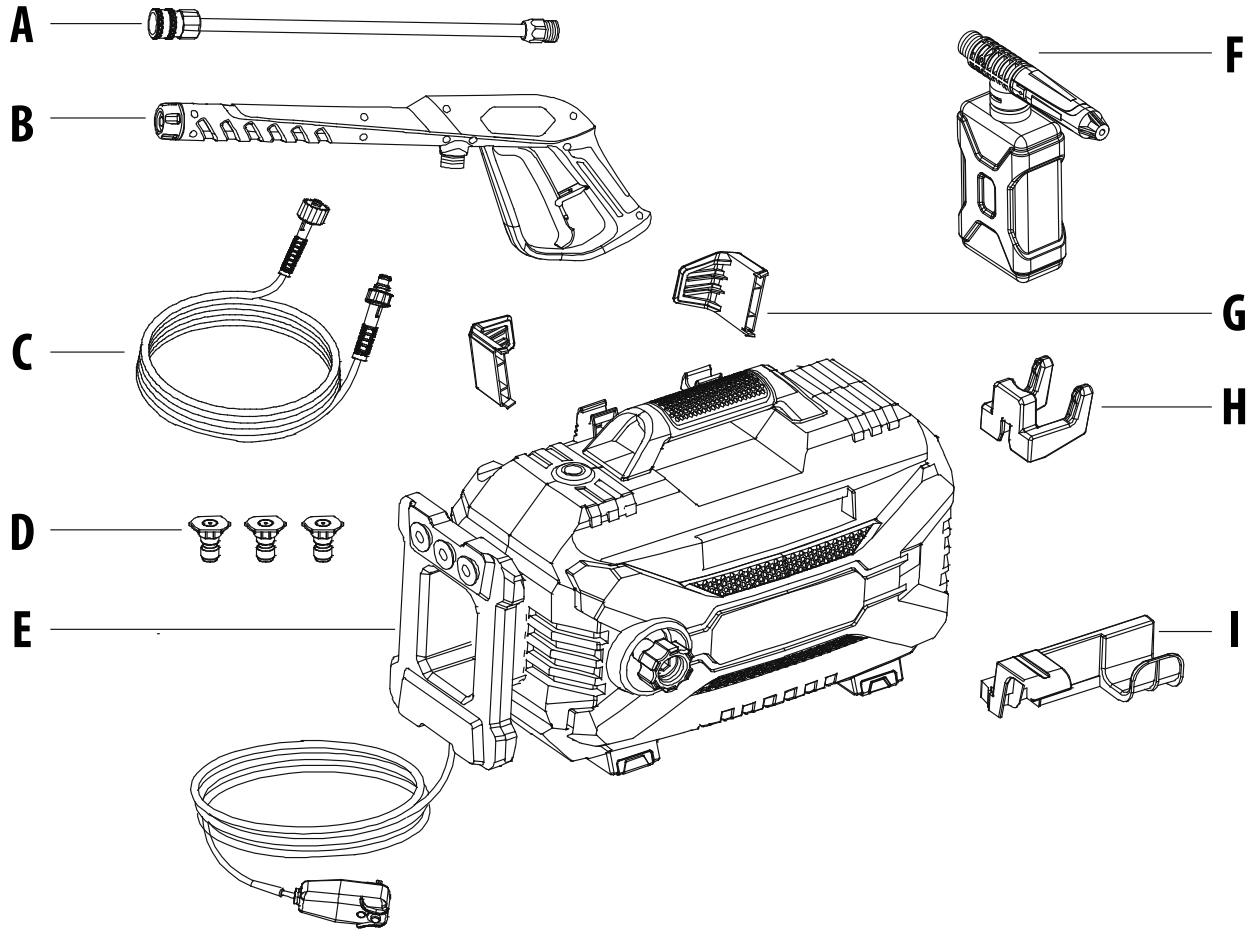

4. PARTS LIST

Item #	Part Name	Qty.	Part #
A	Quick-connect wand	1	XE16-020-0002
B	Gun assembly	1	XE16-020-0003
C	High-pressure hose	1	XE30-010-0005
D	Tips kit (3 pcs)	1	VE20-020-0004
E	Cord bracket	1	VE20-000-0003
F	Foam blaster	1	VE20-060-1000

Item #	Part Name	Qty.	Part #
G	Hose holder kit (2 pcs)	1 set	VE20-000-0004
H	Bottle holder	1	VE10-000-0002
I	Gun holder	1	VE20-000-0005
N/A	Cleaning needle	1	Pre-attached on the manual
N/A	Water filter	1	Pre-attached on the machine

*Water filter come pre-attached on the machine.

5. ASSEMBLY INSTRUCTIONS

5.1 Surface Preparation

Before beginning any cleaning task, it is important to inspect the area for objects that could create a hazard. Remove any objects from the work area that could be tripped over, such as toys or outdoor furniture. Ensure that all doors and windows are closed tightly.

5.2 Water Supply (Cold Water Only)

Only draw water through the unit. The device must be used with cold water supply only. The water hose must be at least 1/2" (13 mm) in diameter. The water flow rate must not fall below 2 GPM (9.1 LPM). The flow rate can be determined by running water for one minute into an empty container. The water supply temperature must not exceed 40 °C (104 °F).

5.3 Safety Advice

CAUTION

- Never use the pressure washer to draw in water contaminated with solvents (e.g. paint thinners, gasoline, oil, etc.).
- Dirt in the water inlet will damage the unit. To avoid this risk, we recommend checking the water filter (located inside the water inlet. To clean it out, refer to the Cleaning and Maintenance section).
- Always prevent debris from being drawn into the unit by using a clean water source and an additional accessory water filter, if required.
- To prolong the life of the unit, let it rest for 5 minutes after every 30 minutes of use.
- Check to make sure you have all the parts.

5.4 Assembly Steps

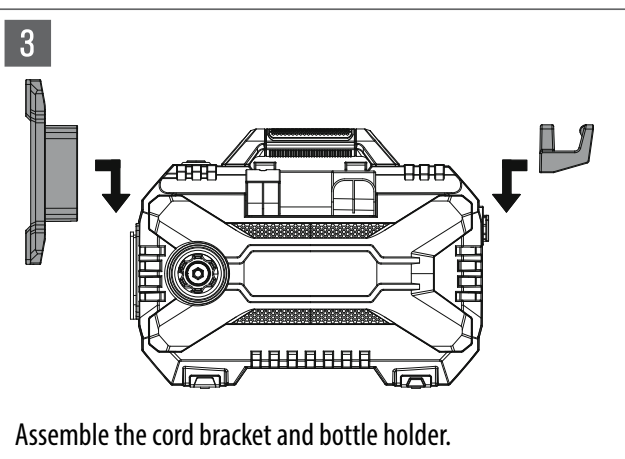
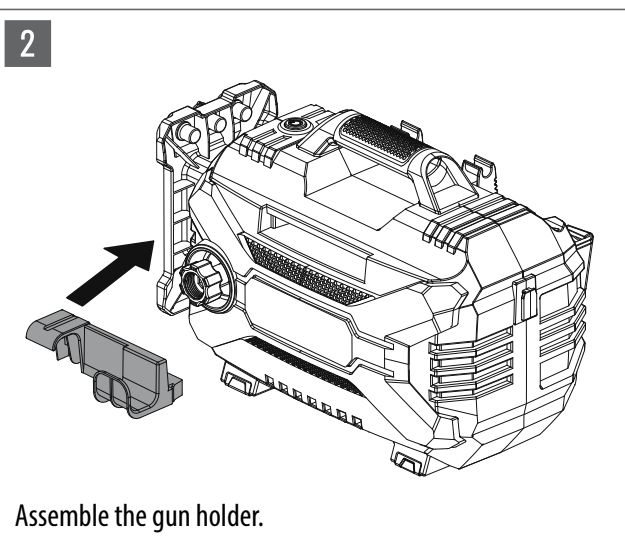
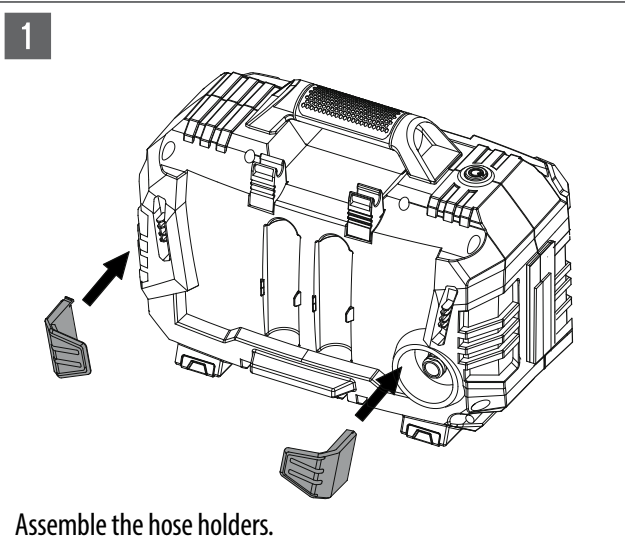

8 Assembly Instructions

5. ASSEMBLY INSTRUCTIONS (CONT.)

5.4 Assembly Steps (cont.)

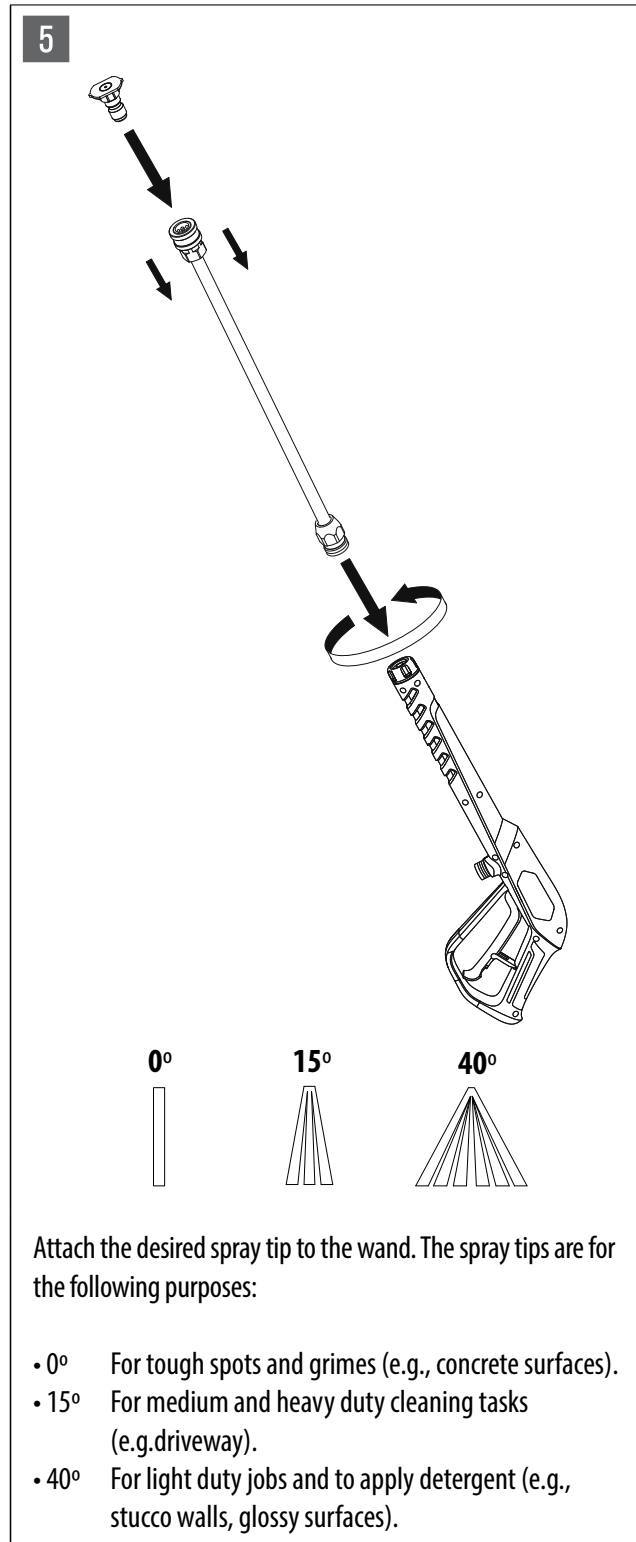
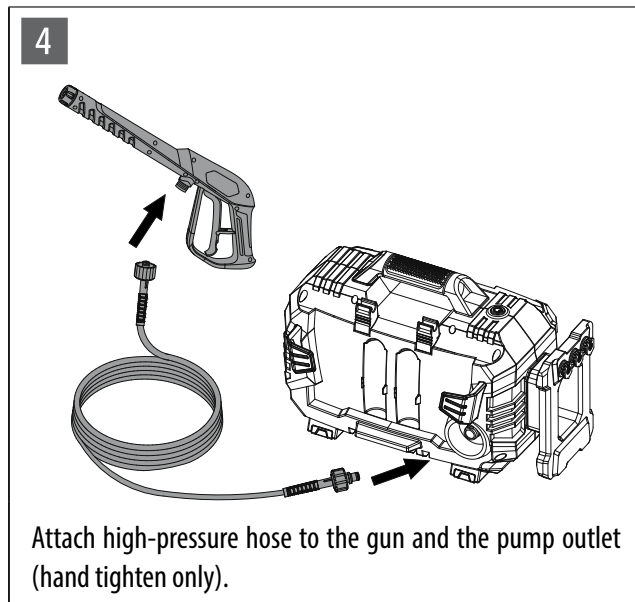

5. ASSEMBLY INSTRUCTIONS (CONT.)

5.4 Assembly Steps (cont.)

6

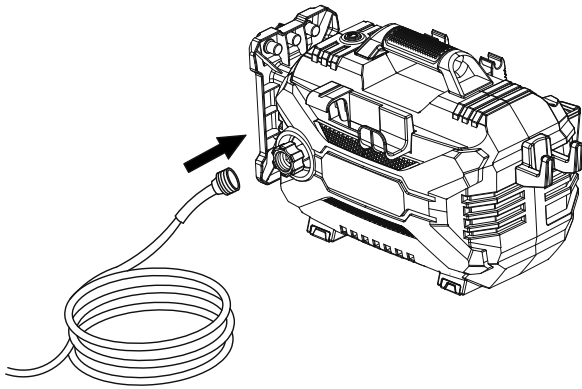

Connect garden hose to the inlet adaptor.

7

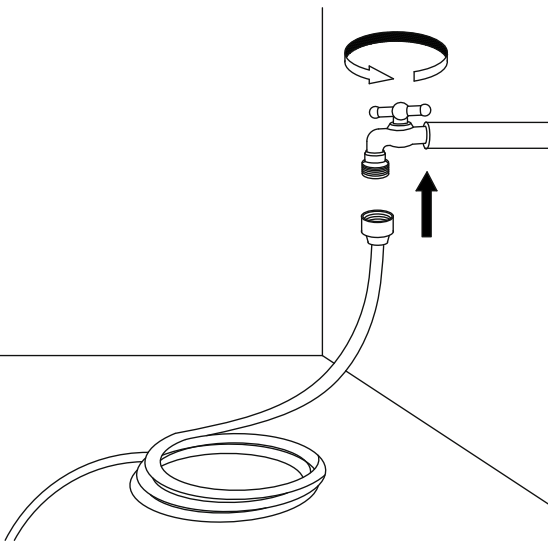

Attach garden hose to water supply and turn water on.

8

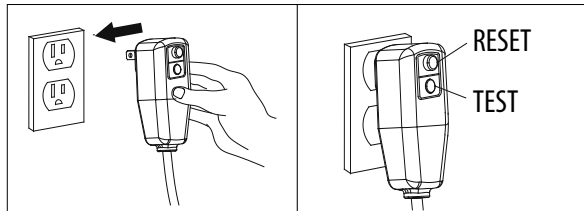
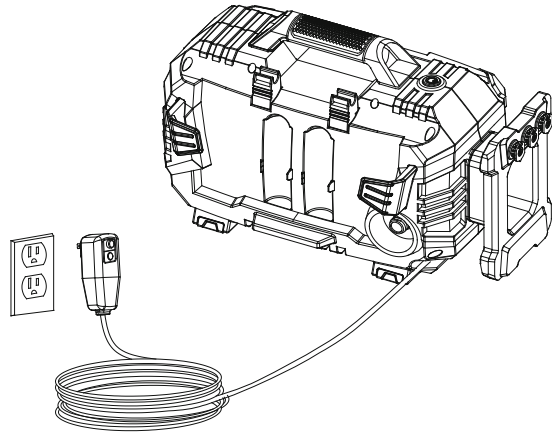

Plug the GFCI plug into an outlet. Firmly press and release the TEST button, then press and release the RESET button. The light on the GFCI should be illuminated.

! WARNING

Make sure your hands are dry. Plug the unit into an outlet.

9

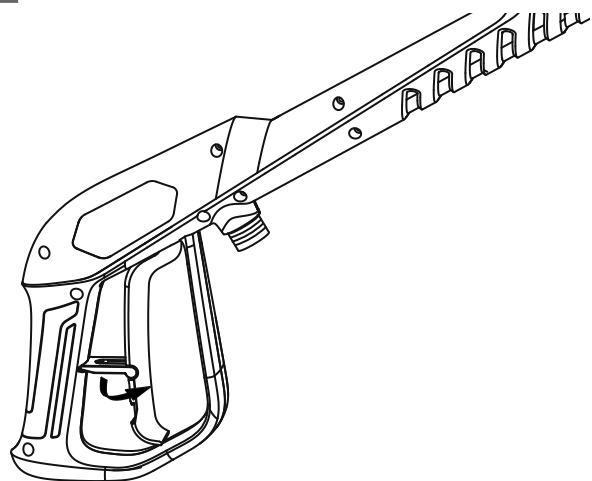

Release the safety trigger if it is locked.

10 Assembly Instructions

5. ASSEMBLY INSTRUCTIONS (CONT.)

5.4 Assembly Steps (cont.)

10

PURGING

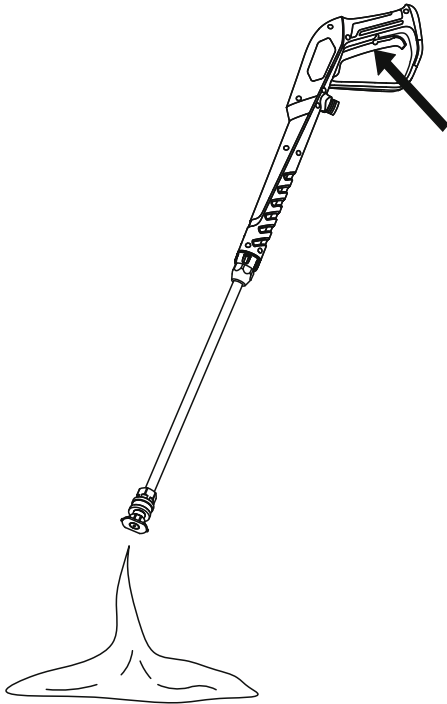

Purge air by squeezing the trigger on the gun until there is a steady stream of water.

CAUTION

Drain unit after each use (for storage): remove water connection, turn ON the machine for a few seconds and press gun trigger to drain remaining water in the pump. Turn OFF immediately.

11

ON/OFF
button

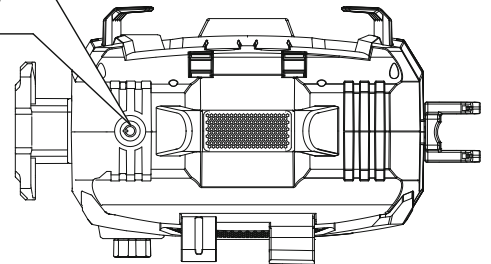

Push the ON/OFF button, LED indicator turns red colour and the machine is ready to operate. Push the ON/OFF button again to set the machine in **OFF** mode.

6. OPERATING INSTRUCTIONS

6.1 Working with Foam Blaster

Working with a detergent ensures quick soaking of the dirt, and allows the high-pressure water to penetrate and remove the dirt more effectively. Always spray detergent on a dry surface, do not pre-soak the area. Wetting the surface first dilutes the detergent and reduces its cleaning ability.

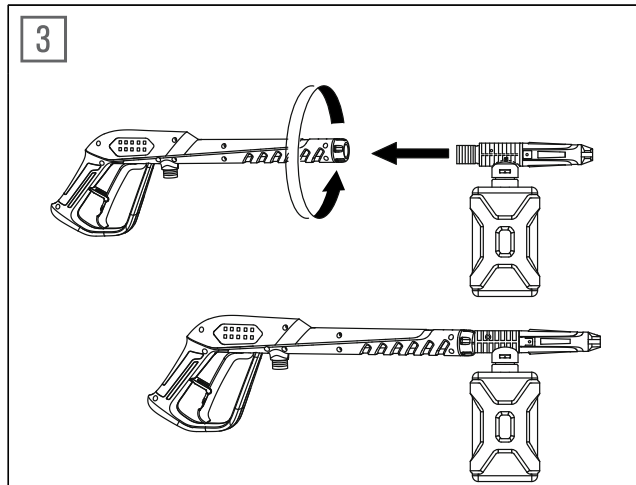
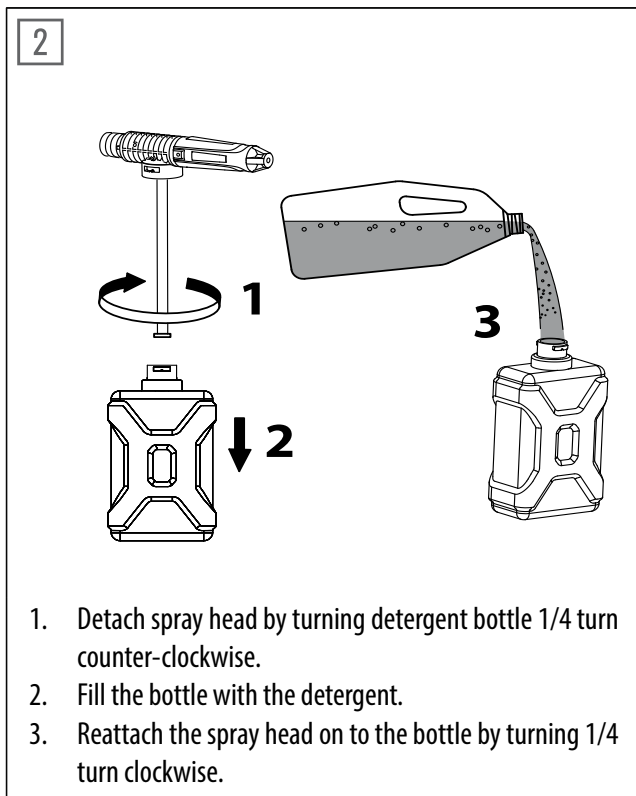
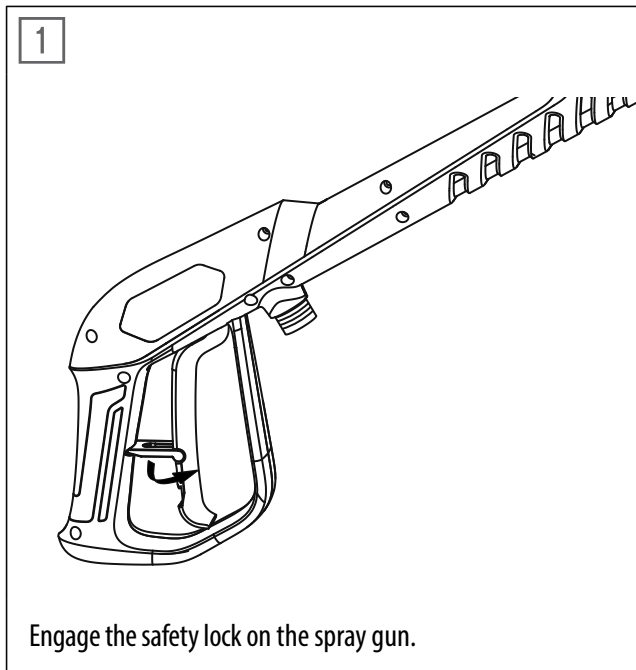

CAUTION

Damage may occur to painted surfaces if chemicals are allowed to dry on them. Wash and rinse a small section at a time.

12 Operating Instructions

6. OPERATING INSTRUCTIONS (CONT.)

6.2 Shutting Down and Cleaning Up

1	Turn off water supply and disconnect the garden hose from the water inlet on the pressure washer.
2	Pull the trigger to release any remaining water pressure.
3	Set the ON/OFF switch to the OFF position.
4	Unplug the power cord from the outlet.
5	Engage the safety lock on the spray gun.

WARNING

Turn off the water supply and pull the trigger to depressurize the device. Failure to do so might result in personal injury due to discharge of high-pressure water.

6.3 Taking Breaks

If taking a five minute or longer break while using the pressure washer:

1	Engage the safety lock on the the spray gun.
2	Set the ON/OFF switch to the OFF position.
3	Unplug the power cord from the outlet.

6.4 Warnings

CAUTION

Failure to clean this product properly will cause the detergent injection system to become clogged and inoperable.

WARNING

Never use:

- Bleach, chlorine products or other corrosive chemicals;
- Liquids containing solvents (i.e., paint thinners, gasoline, oils, etc.);
- Tri-sodium phosphate products;
- Ammonia products; or
- Acid-based products.

These chemicals will harm the unit and will damage the surface being cleaned.

7. WINTERIZING AND LONG-TERM STORAGE

7.1 Optimum Winterizing Procedure

Winterizing your pressure washer will help protect and prolong its life. We strongly recommend you follow the below steps using a Pressure Washer Antifreeze before storing for the winter. This will keep the internal parts lubricated, protected from rust, and prevents the pump from freezing.

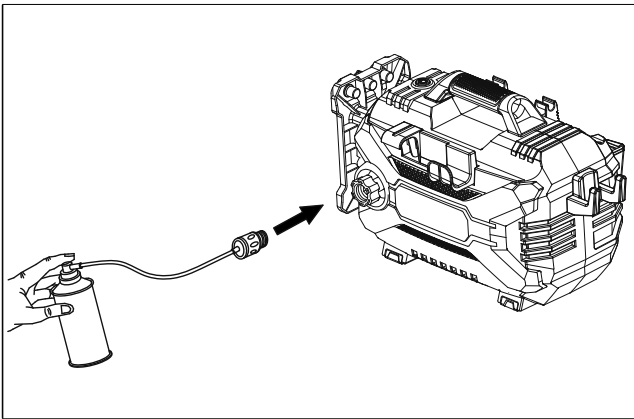

1. Connect the Pump Saver to the inlet adaptor.
2. Depress button on top of the pump saver container.
3. Continue until fluid exits the pressure hose.
4. Remove the hose from pump inlet.

WARNING

Flush the pressure washer unit out with clear water before reusing. Anti-freeze can damage the paintwork and product, so you must ensure there is no anti-freeze left in product system before using it again.

CAUTION

Drain any remaining water from the gun assembly. Aim the gun downwards and pull the trigger.

WARNING

Store the pressure washer unit in a location where temperature does not fall below 32°F (0°C) at all times. The pump in the machine is susceptible to damage if exposed to cold temperatures. **FREEZE DAMAGE IS NOT COVERED BY THE WARRANTY.**

7.2 Quick Winterizing Procedure

If you are unable to perform the Optimum Winterizing Procedure, you can still protect your pressure washer from winter damage by doing the following:

- Disconnect all water connections.
- Turn on the device for a few seconds, until the remaining water flows out of the pump. Turn the device off immediately after that.
- Do not allow the high-pressure hose to become kinked.
- Store the device and its accessories in a room that does not reach freezing temperatures. Do not store them near furnaces or other sources of heat, as that might dry out the pump seals.
- Recommended: Pressure Washer Antifreeze.

8. CLEANING AND MAINTENANCE

8.1 Connections

The connections on the pressure washer's hoses, gun, and spray wand should be cleaned and lubricated with non-water soluble grease regularly.

8.2 Cleaning the Nozzles

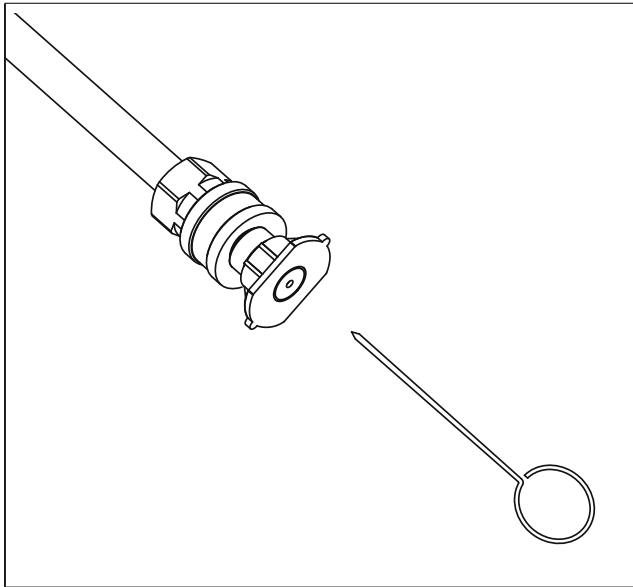

Clogging of the nozzle causes the pump pressure to be too high, making it necessary to clean the nozzle immediately. You can clean the nozzle by carefully inserting the cleaning needle or a thin, sharp instrument (i.e. paperclip) into the tip to clean out any deposits.

8.3 Water Filter Screen

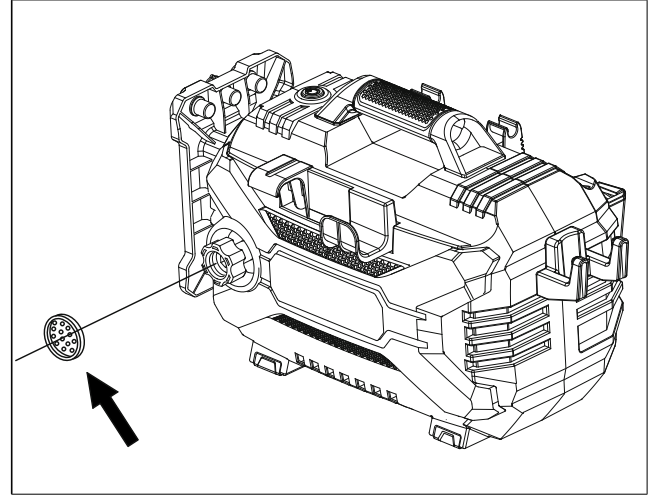

The pressure washer is equipped with a water inlet screen to protect the pump. If the screen is not kept clean, the flow of water to the pressure washer will be restricted, and the pump may become damaged.

To clean the water inlet screen:

- Remove the filter screen from inside the inlet adaptor (the inlet adaptor comes pre-assembled to the machine).
- Rinse the screen until it is free of debris and obstructions.
- Place the screen back to prevent foreign particles from entering the pump.

9. TECHNICAL SPECIFICATIONS

Peak pressure:	1800 PSI (12.4 MPa)
Rated pressure:	1100 PSI (7.6 MPa)
Power source requirement:	120 V / 60 Hz
Electric code with GFCI:	35' (10.7 m) 16 AWG
High-pressure hose:	20' (6 m)
US GPM:	2.0 GPM (7.6 LPM)
Current drawn:	13 A
Inlet water:	Cold tap water
CU (cleaning units):	3600
Motor:	Universal
Pump:	Aluminum, indirect-drive

10. TROUBLESHOOTING

Disconnect the device from the power source before making any repairs.

Problem	Cause	Solution
The motor does not start.	The device is in OFF mode.	Push the ON/OFF button once to turn to the ON mode.
	The power cord is not plugged in.	Plug in the power cord.
	The extension cord is too long. The extension cord is not the proper gauge. The extension cord is damaged.	Replace the extension cord with either a 25' (7.6 m) 14/3 gauge cord or a 50' (15 m) 14/3 gauge cord.
	The power outlet does not supply adequate power.	Try a different outlet.
	Tripped pressure washer circuit breaker.	Allow the device to cool, and then restart it.
The device does not reach high pressures.	The garden hose is too small.	Replace it with a 1" (25 mm) or 5/8" (16 mm) garden hose.
	Water supply is restricted.	Check the garden hose for kinks, leaks or blockage.
	Not enough water supply.	Open water source fully.
	The water inlet filter is clogged.	Remove the filter and rinse it with warm water.

Problem	Cause	Solution
The device does not reach high pressures (continued).	The pump is sucking air.	Check if all hoses and fittings are airtight. Turn the device to OFF mode, and purge the pump by pulling the trigger on the spray gun until a steady flow of water emerges through the nozzle.
	Output pressure fluctuates high and low.	Not enough inlet water supply. The pump is sucking air.
Foam blaster is not working.	Turn faucet on fully. Check garden hose for kinks, leaks or blockage.	Check if all hoses and fittings are airtight. Turn the device OFF , and purge the pump by pulling the trigger on the spray gun until a steady flow of water emerges through the nozzle.
	The water inlet filter is clogged.	Remove the filter and rinse it with warm water.
	The discharge nozzle is obstructed.	Blow out or remove debris with a fine needle.
	Calcified gun, hose, or power nozzle.	Run distilled vinegar through the detergent container.
	Detergent container is empty.	Add more detergent.
Detergent bottle or suction tube not properly connected.	Check connections.	
Detergent is too thick.	Dilute detergent.	
The filter on the detergent suction tube is clogged.	Run warm water through the filter to remove build-up.	
Damaged or clogged detergent suction tube.	Remove obstruction or replace the detergent suction tube.	

10. TROUBLESHOOTING (CONT.)

Problem	Cause	Solution
The garden hose connection leaks.	Loose fittings.	Tighten fittings.
	Missing/worn rubber washer.	Insert new washer.
Spray wand, extension, or nozzle leaks.	The spray nozzle was not properly attached.	Ensure the quick-connect wand is attached securely. Ensure the project tip is clicked in securely.
	Broken O-ring or plastic insert.	Call the Toll-free Hotline.
The pump is noisy.	The pump is sucking air.	Check if all hoses and fittings are airtight. Turn the device to OFF mode and purge the pump by pulling the trigger on the spray gun until a steady flow of water emerges through the nozzle.
	The water filter is clogged.	Remove the filter and rinse it with warm water.
Water leaks from the pump (up to 10 drops per minute is permissible).	Loose fittings.	Check if all fittings are tight.
	Water seals are damaged or worn.	Call the Toll-free Hotline.
Oil is dripping.	Oil seals are damaged or worn.	Call the Toll-free Hotline.

Problem	Cause	Solution
Motor hums but fails to run.	Supply voltage below minimum.	Verify that only the pressure washer is running on this circuit.
	System has residual pressure.	Turn the device to OFF mode, pull the trigger on the spray gun to release pressure, and then turn the device back ON .
	Voltage loss due to the extension cord.	Unplug any extension cords attached and plug the unit directly into the outlet.
	Residual friction among components. The device might hum.	Disconnect water supply and power ON for 2 to 3 seconds. Repeat this procedure a few times, or until the motor starts.
No water coming out of the nozzle.	Water supply is OFF.	Turn on the water supply.
	Kink in the garden hose.	Remove the kink in the garden hose.

IF YOU ENCOUNTER ANY ADDITIONAL DIFFICULTIES NOT LISTED, VISIT OUR WEBSITE AT

WWW.ACTIVE-JOBSITE.COM

OR CALL CUSTOMER SERVICE FOR HELP AT

1-844-777-4555.

11. WARRANTY

Always keep your online receipt as proof of purchase.

We're here to help! If you have any questions or comments, call our toll-free hotline 1-844-777-4555. Have your serial number ready. The serial number can be found on the back plate, located on the side of the unit.

Two (2) Year Warranty

This product is guaranteed to be free from defects in material and workmanship for two years from the date of its original purchase. If such a defect appears during the warranty period, upon presentation of proof of purchase and damage, Active Products will elect to either (1) replace the product or defective component at no charge and free shipping or (2) refund the full purchase price to the owner (at its discretion).

What is Not Covered?

The warranty is void if the equipment is used for commercial, rental or industrial purposes.

This warranty does not cover accidental damage, unreasonable use, and normal wear and tear like belts, chains and tine, use of improper detergents, freezing, neglect, or non-compliance with the operating Instructions. The warranty does not cover loss of use or other consequential damages arising from any of the above, nor does it cover repairs made or attempted by unauthorized persons.

Note: Batteries are covered in full for 90 days from the date of purchase.

If you have further questions, please visit our website (www.active-jobsite.com) or call 1-844-777-4555.

ACTIVETM