

Body-Solid

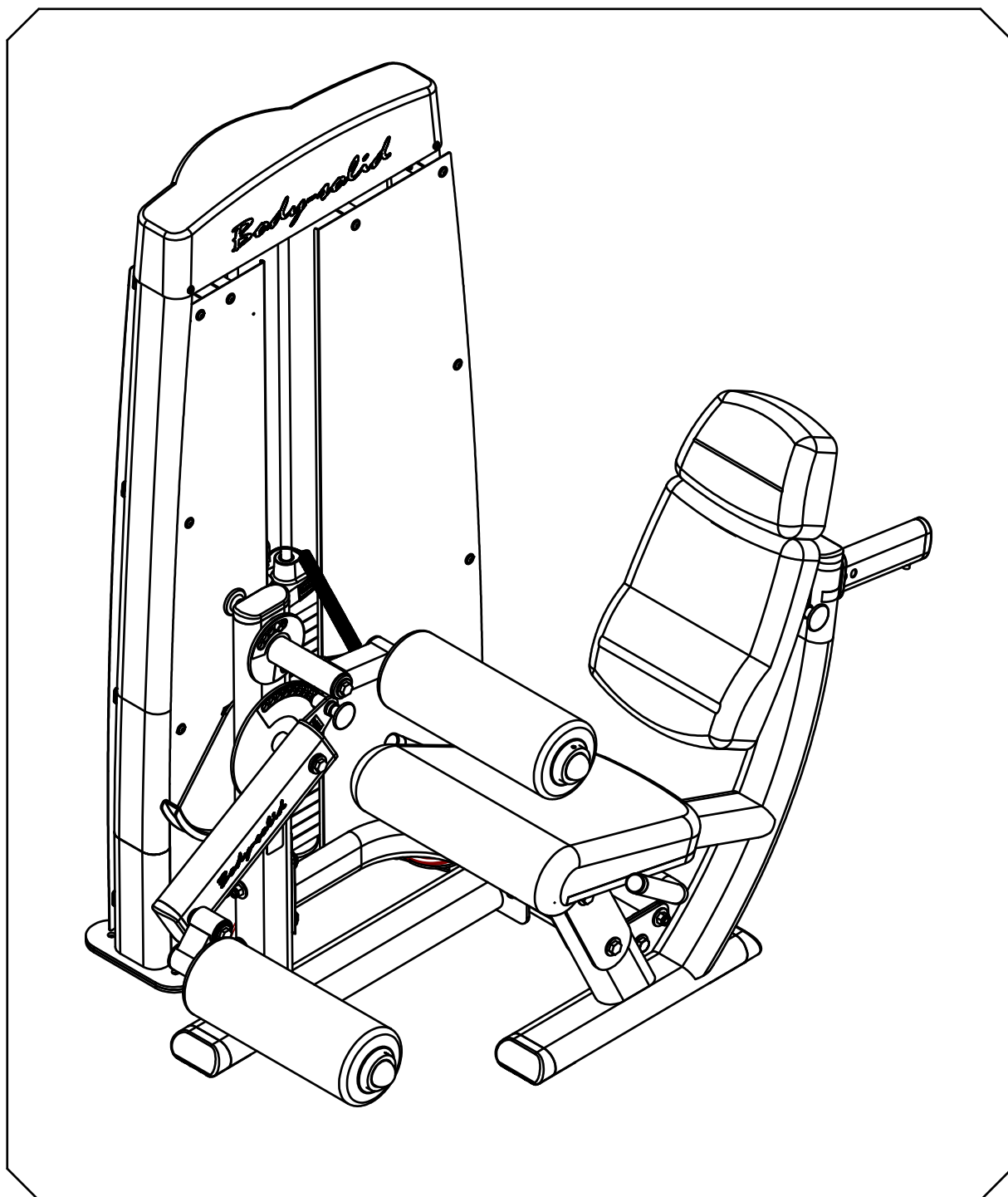

BODY-SOLID, Inc.
1900 S. Des Plaines Ave.
Forest Park, IL 60130 USA
Phone: (708) 427-3555
Fax: (708) 427-3556
www.bodysolid.com

DLEC.2 OWNER'S MANUAL

DLEC ASSEMBLY INSTRUCTIONS

HARDWARW ILLUSTRATION

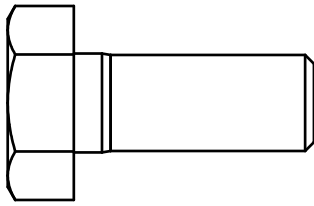

(A1)HEX BOLT 1/2"X1-1/4"L PARTIAL QTY.2

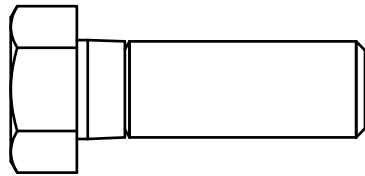

(A2)HEX BOLT 1/2"X1-1/2"L PARTIAL QTY.3

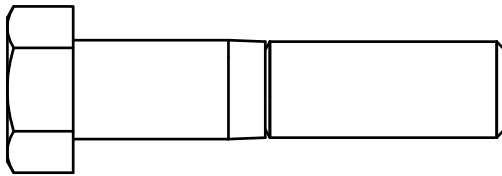

(A3)HEX BOLT 1/2"X2-1/4"L PARTIAL QTY.1

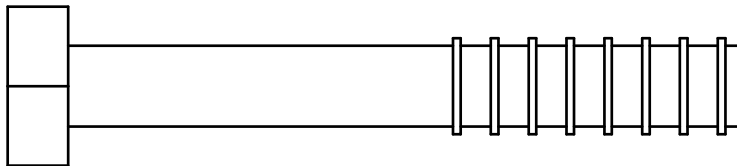

(A4)HEX BOLT 1/2"X3-1/2"L PARTIAL QTY.2

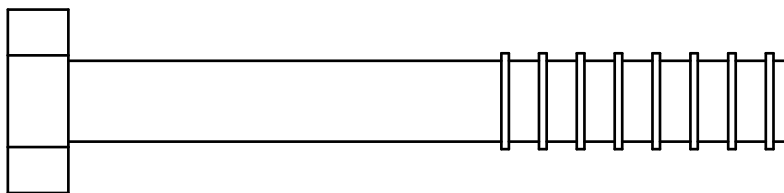

(A5)HEX BOLT 1/2"X3-3/4"L PARTIAL QTY.1

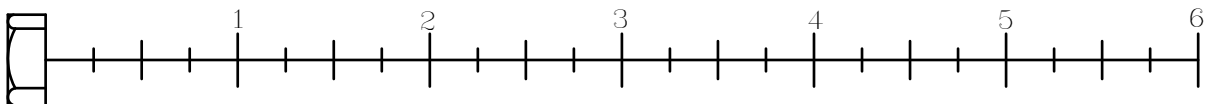

DLEC ASSEMBLY INSTRUCTIONS

HARDWARW ILLUSTRATION

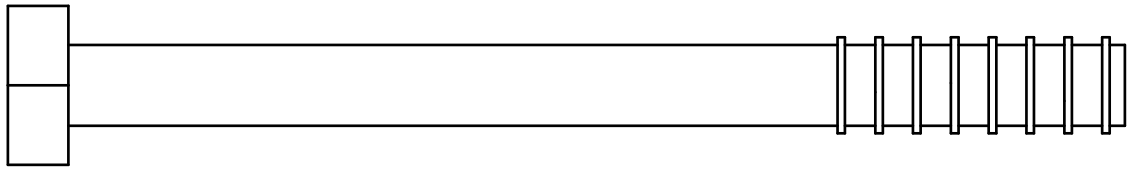

(A6)HEX BOLT 1/2"X5-1/2"L PARTIAL QTY.2

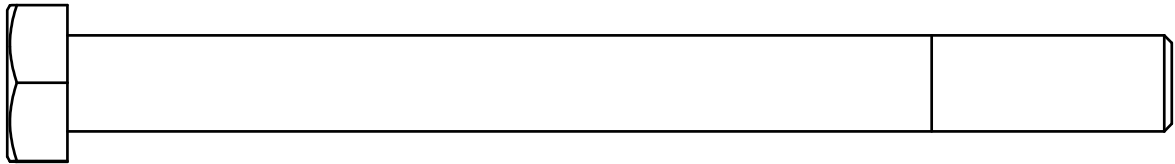

(A7)HEX BOLT 1/2"X5-3/4"L PARTIAL QTY.2

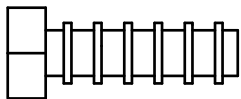

(A8)HEX BOLT 5/16"X1"L PARTIAL QTY.6

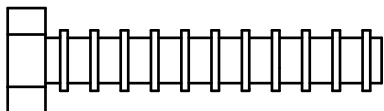

(A9)HEX BOLT 5/16"X1-3/4"L PARTIAL QTY.1

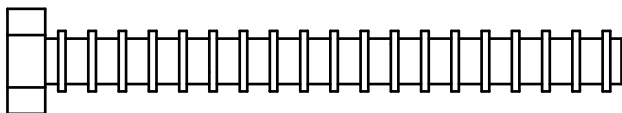

(A10)HEX BOLT 5/16"X3"L PARTIAL QTY.1



DLEC ASSEMBLY INSTRUCTIONS

HARDWARW ILLUSTRATION

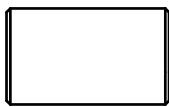
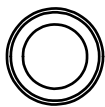

(A11)STEEL BUSHING $\varnothing 1/2" \times \varnothing 8.5 \times 21L$ QTY.1

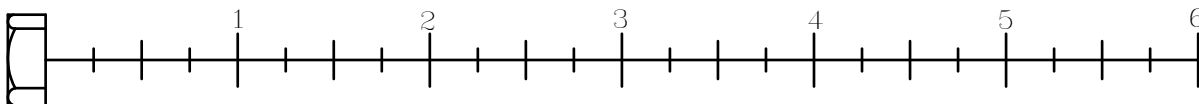

DLEC ASSEMBLY INSTRUCTIONS

HARDWARW ILLUSTRATION

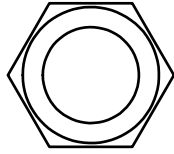
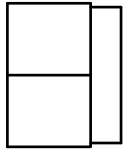

(B1) NYLON LOCK NUT 1/2" QTY.13

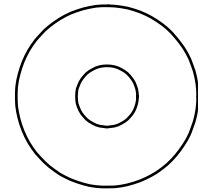

(C4) 5/16" (I.D.) FLAT WASHER Ø24 QTY.7

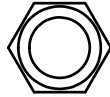

(B2) NYLON LOCK NUT 5/16" QTY.1

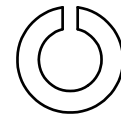

(C5) SPRING WASHER 5/16" QTY.7

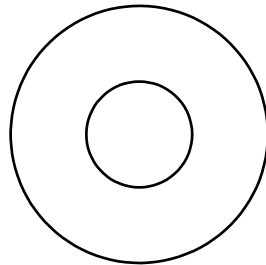

(C1) 1/2" (I.D.) FLAT WASHER Ø34 QTY.20

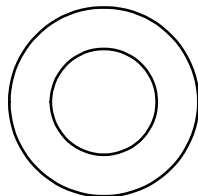

(C2) 1/2" (I.D.) FLAT WASHER Ø25 QTY.6

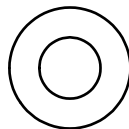

(C3) 5/16" (I.D.) FLAT WASHER Ø16 QTY.2

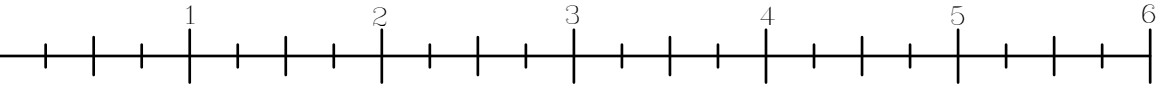

DLEC ASSEMBLY INSTRUCTIONS

HARDWARW ILLUSTRATION

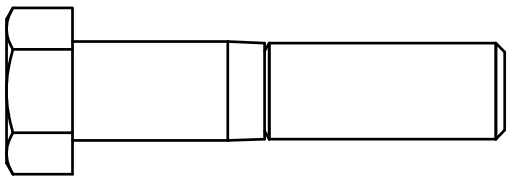

(AA2)HEX BOLT 1/2"X2-1/4"L PARTIAL QTY.3

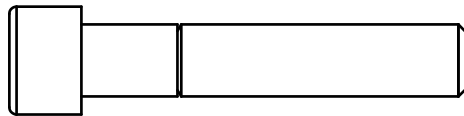
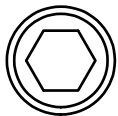

(AA4)ROUND INNER HEAD 3/8"X2"L PARTIAL QTY.1

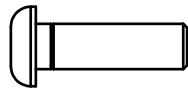

(AA5)ROUND INNER HEX SCREW M6X20L PARTIAL QTY.20



(AA6)ROUND CROSS SCREW 5/32"X1/4"L PARTIAL QTY.4

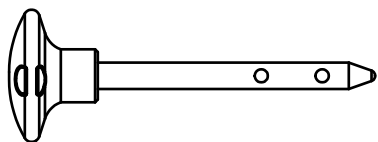

(AA7)10LB PIN(8250-071) QTY.1

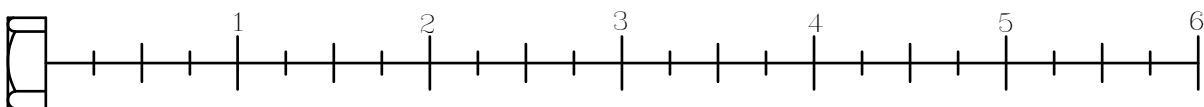

DLEC ASSEMBLY INSTRUCTIONS

HARDWARW ILLUSTRATION

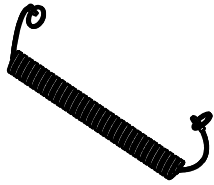

(AA8)ELASTIC BOLT QTY.1

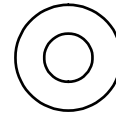

(CC2)M6(I.D.)FLAT WASHER Ø13 QTY.20

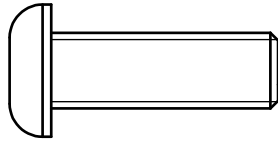
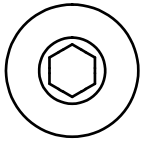

(AA10)ROUND INNER HEX SCREW
M10X30L PARTIAL QTY.1

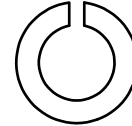

(CC5)SPRING WASHER 3/8" QTY.1

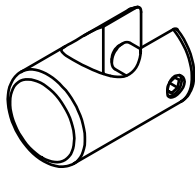

(AA11)FIRM SHEATH(8890-046) QTY.1

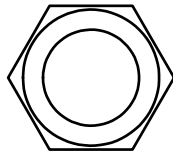
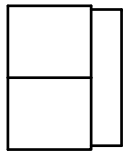
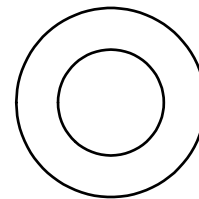
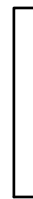

(CC6)1/2"(I.D.)FLAT WASHER Ø25 QTY.2

(BB2)NYLON LOCK NUT1/2" QTY.3

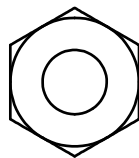
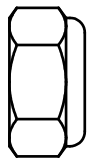

(BB3)NYLON LOCK NUT M10 QTY.1

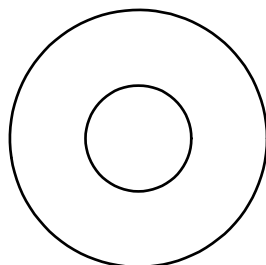
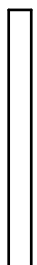







(CC1)1/2"(I.D.)FLAT WASHER Ø34 QTY.4



DLEC ASSEMBLY INSTRUCTIONS

HARDWARW ILLUSTRATION

- | | | |
|---|---|--|
| D1 | D2 | (D1) $\phi 3/4$ " X 13.5 X 8L STEEL BUSHING (8110-014) ----- [2PCS] |
|  |  | (D2) $\phi 25.4$ X $\phi 20.4$ X 10L STEEL BUSHING (8120-040) ----- [1PCS] |
| D3 | D4 | (D3) $\phi 38$ " X $\phi 25.2$ X 27L STEEL BUSHING (8130-159) ----- [1PCS] |
|  |  | (D4) $\phi 30$ " X $\phi 20$ X 1.5t CU WASHER (8520-007) ----- [1PCS] |
| D5 | D6 | (D5) $\phi 38$ " X $\phi 26$ X 1.5t CU WASHER (8520-008) ----- [3PCS] |
|  |  | (D6) $\phi 50$ ROUND END CAP (9211-074) ----- [2PCS] |
| | | (D7) 50 X 100 NYLON BUSHING (9211-107) ----- [2PCS] |
| | | (D8) 58 X 116 X 2.5t X 65H FOOT CAP (9211-109) ----- [3PCS] |
| | | (D9) 58 X 116 X 2.5t END CAP (9211-112) ----- [4PCS] |
| | | (D10) 40 X 80 X 2t END CAP (9211-113) ----- [1PCS] |
| | | (D11) $\phi 4$ " PULLEY (9213-017A) ----- [2PCS] |
| | | (D12) $\phi 4$ 1/2" PULLEY (9213-010B) ----- [5PCS] |
| | | (D13) $\phi 50$ END CAP (9211-020) ----- [2PCS] |
| | | (D14) $\phi 90$ X $\phi 51$ X 3t NYLON WASHER (9214-022) ----- [4PCS] |
| | | (D15) 207 X 105 X 23 END CAP (9211-115) ----- [1PCS] |
| | | (D16) $\phi 131$ X 30 END CAP (9211-116) ----- [1PCS] |
| | | (D17) 3580mm STEEL CABLE (FDLECA) ----- [1PCS] |
| | | (D18) $\phi 3/4$ " SHAFT COLLAR (9211-046) ----- [2PCS] |
| | | (D19) $\phi 4$ " RUBBER DOUNT (9310-017) ----- [2PCS] |
| | | (D20) TOP PLATE (8400-006) ----- [1PCS] |
| | | (D22) 95 X 250 RUBBER PAD (9310-060) ----- [2PCS] |
| | | (D23) DLEC FOR DGYM CABLE (FDLECB) ----- [1PCS] |
| | | (D24) WEIGHT SELECTOR BAR (8210-042B) ----- [1PCS] |

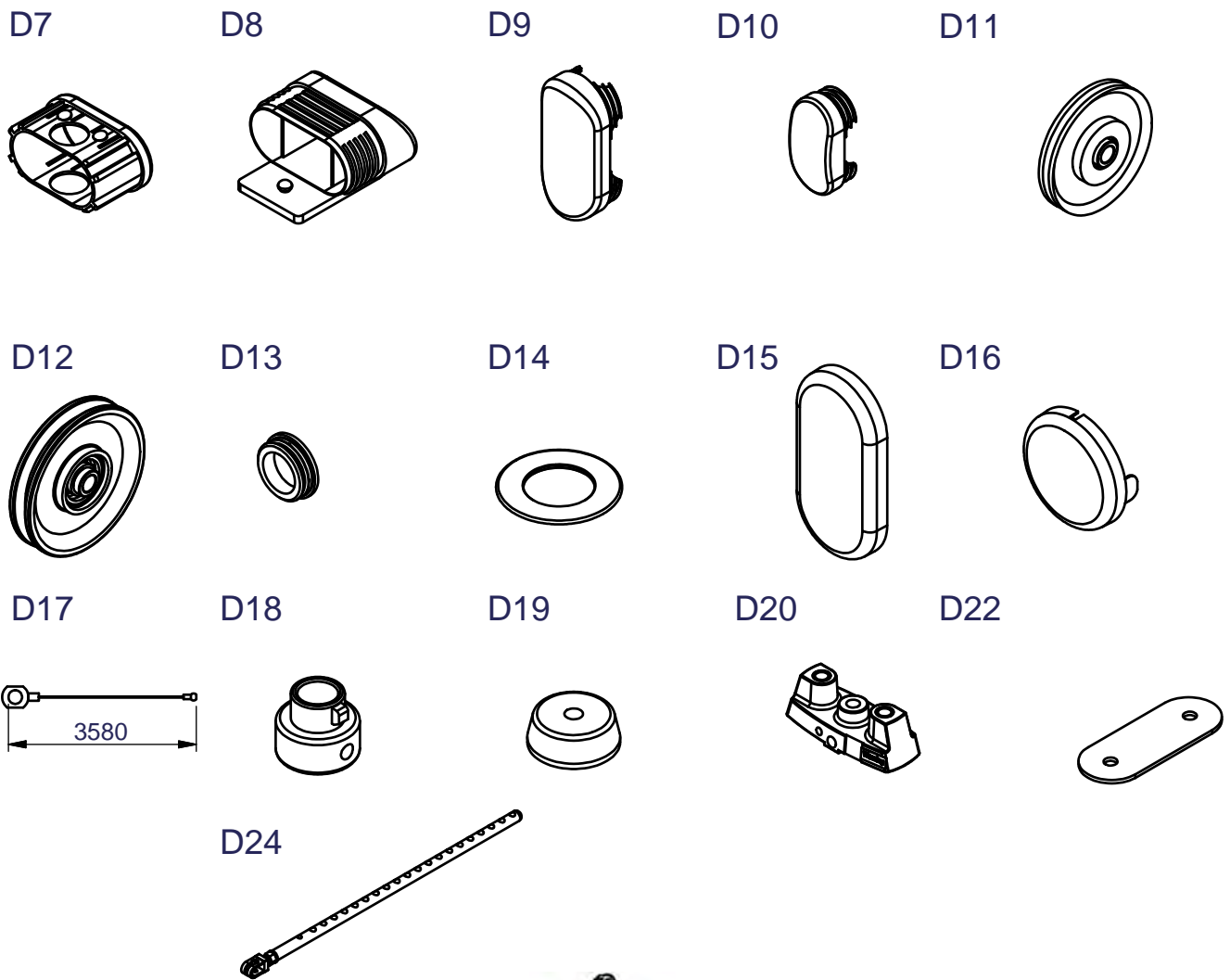

DLEC ASSEMBLY INSTRUCTIONS

PARTS ILLUSTRATION

A2 [1PCS]

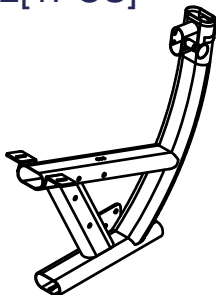

B [1PCS]

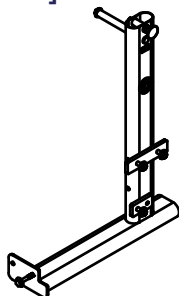

C [1PCS]

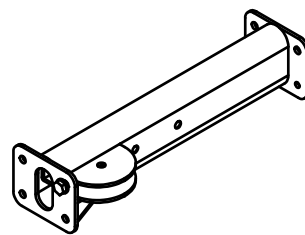

D [1PCS]

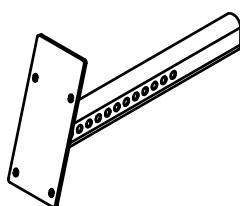

E [1PCS]

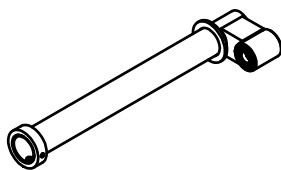

F [1PCS]

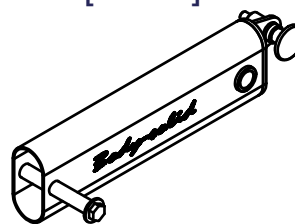

G1 [1PCS]

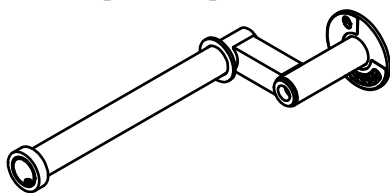

H [1PCS]

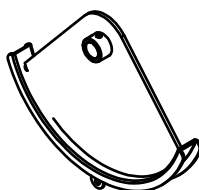

I [1PCS]

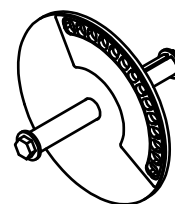

J [1PCS]

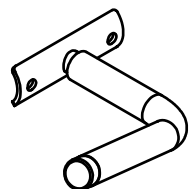

K [1PCS]

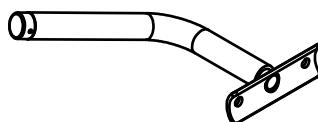

L [1PCS]

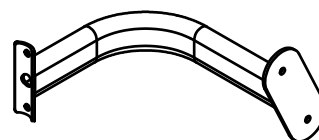

M [1PCS]
8321-062

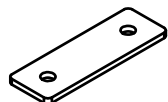

N [1PCS]
8313-135

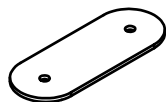

O [1PCS]
9111-055

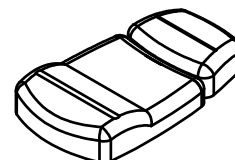

P [2PCS]
9121-053

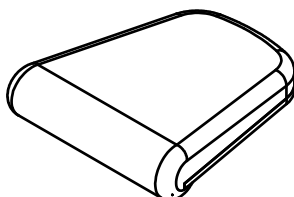

Q [2PCS]
9161-034

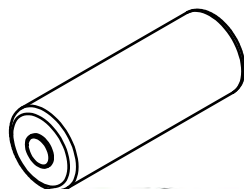

R [1PCS]
9440-161

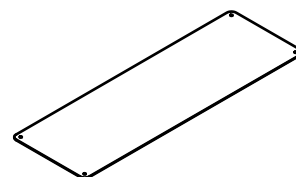

DLEC ASSEMBLY INSTRUCTIONS

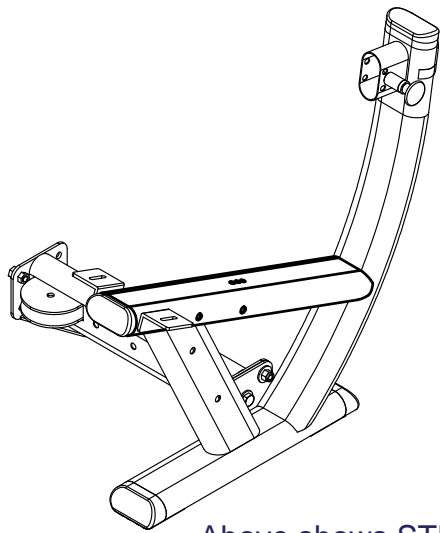

Above shows STEP 1 assembled and completed

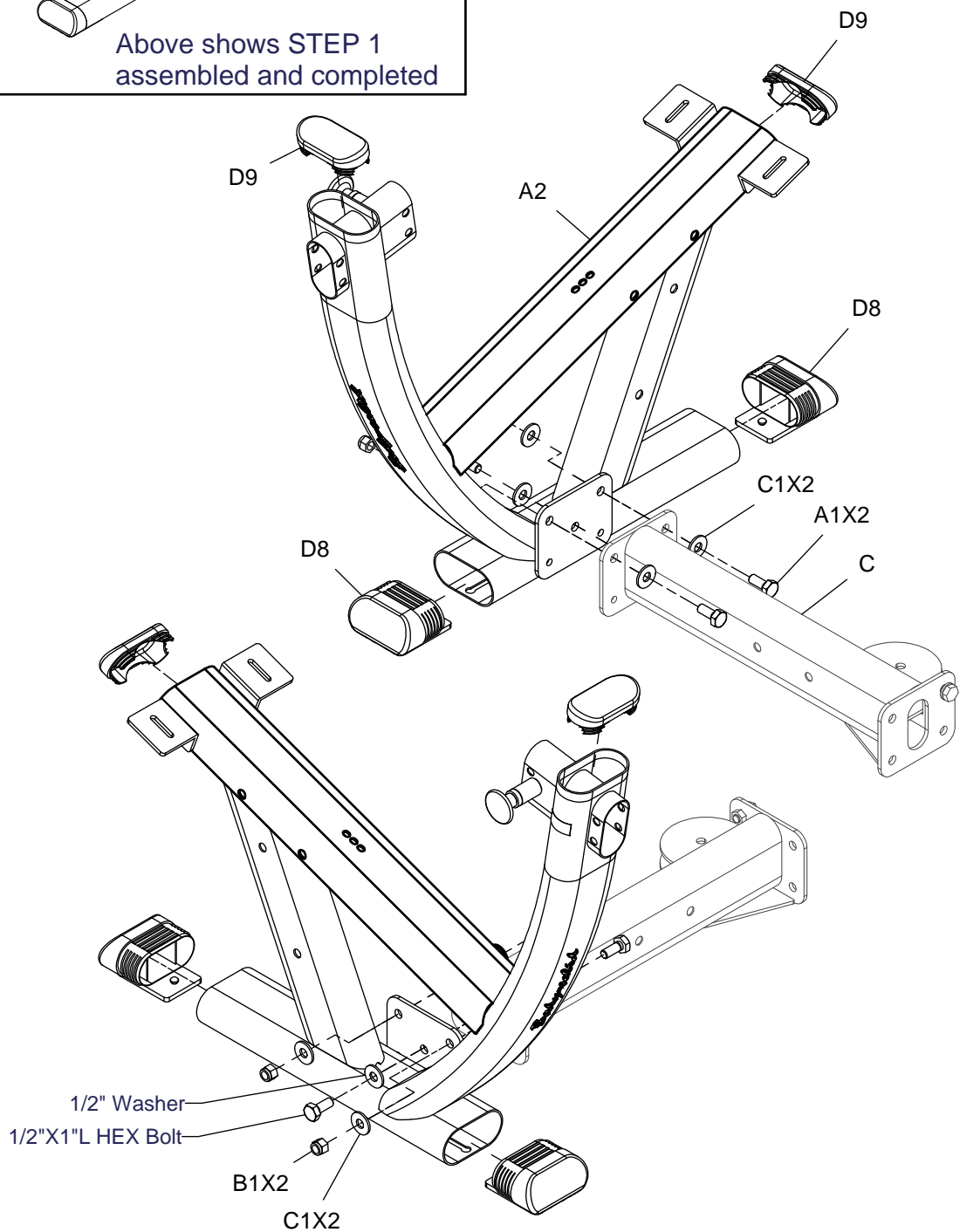

DLEC ASSEMBLY INSTRUCTIONS

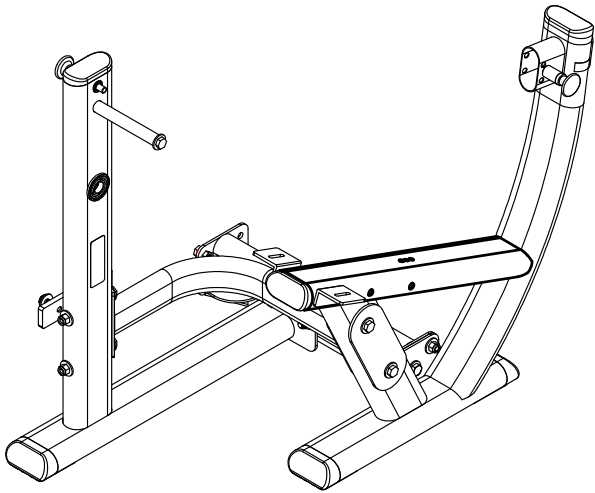

Above shows STEP 2 assembled and completed

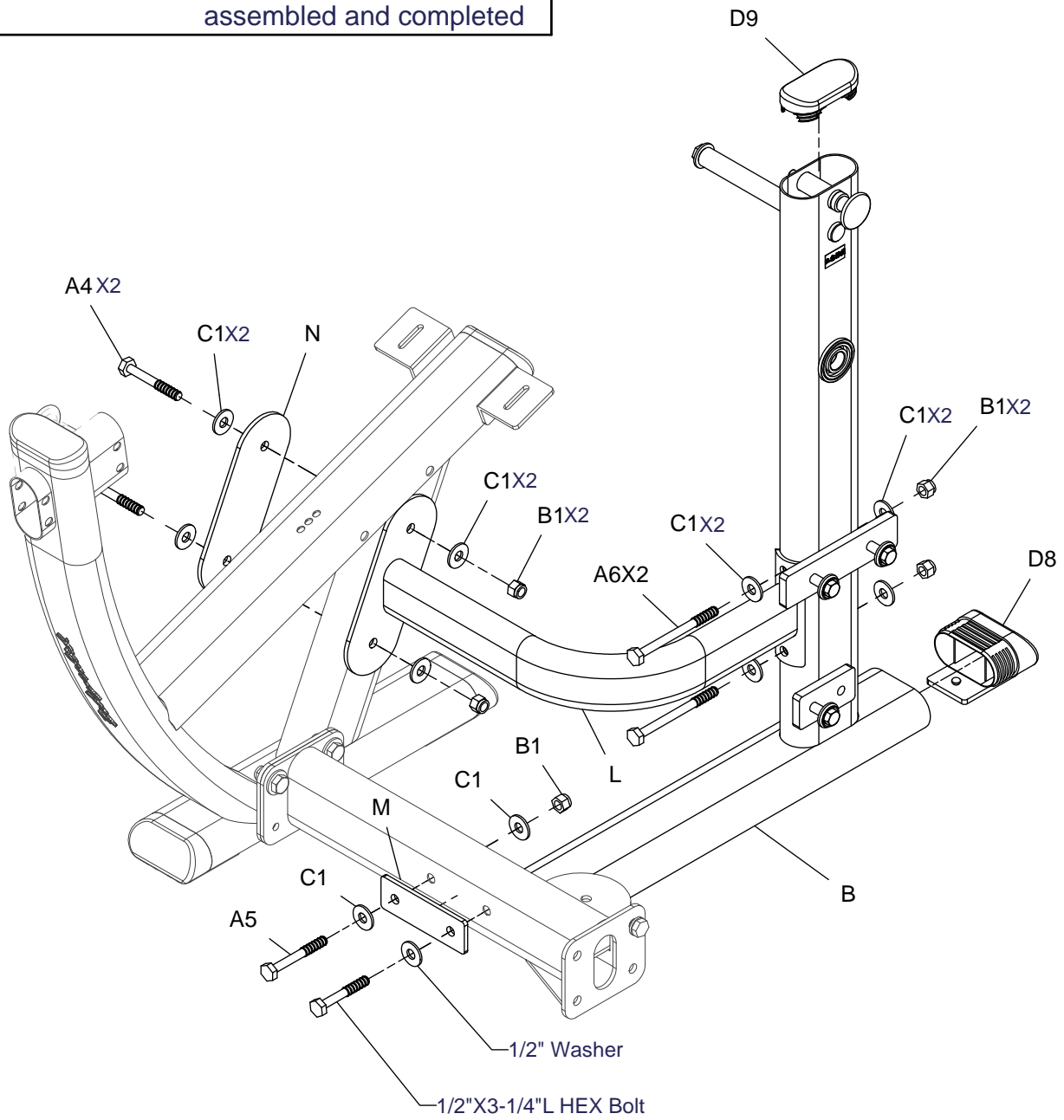

DLEC ASSEMBLY INSTRUCTIONS

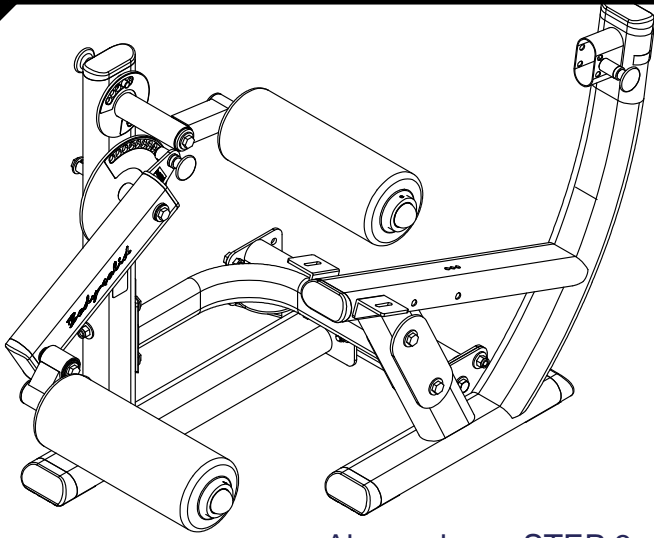

Above shows STEP 3 assembled and completed

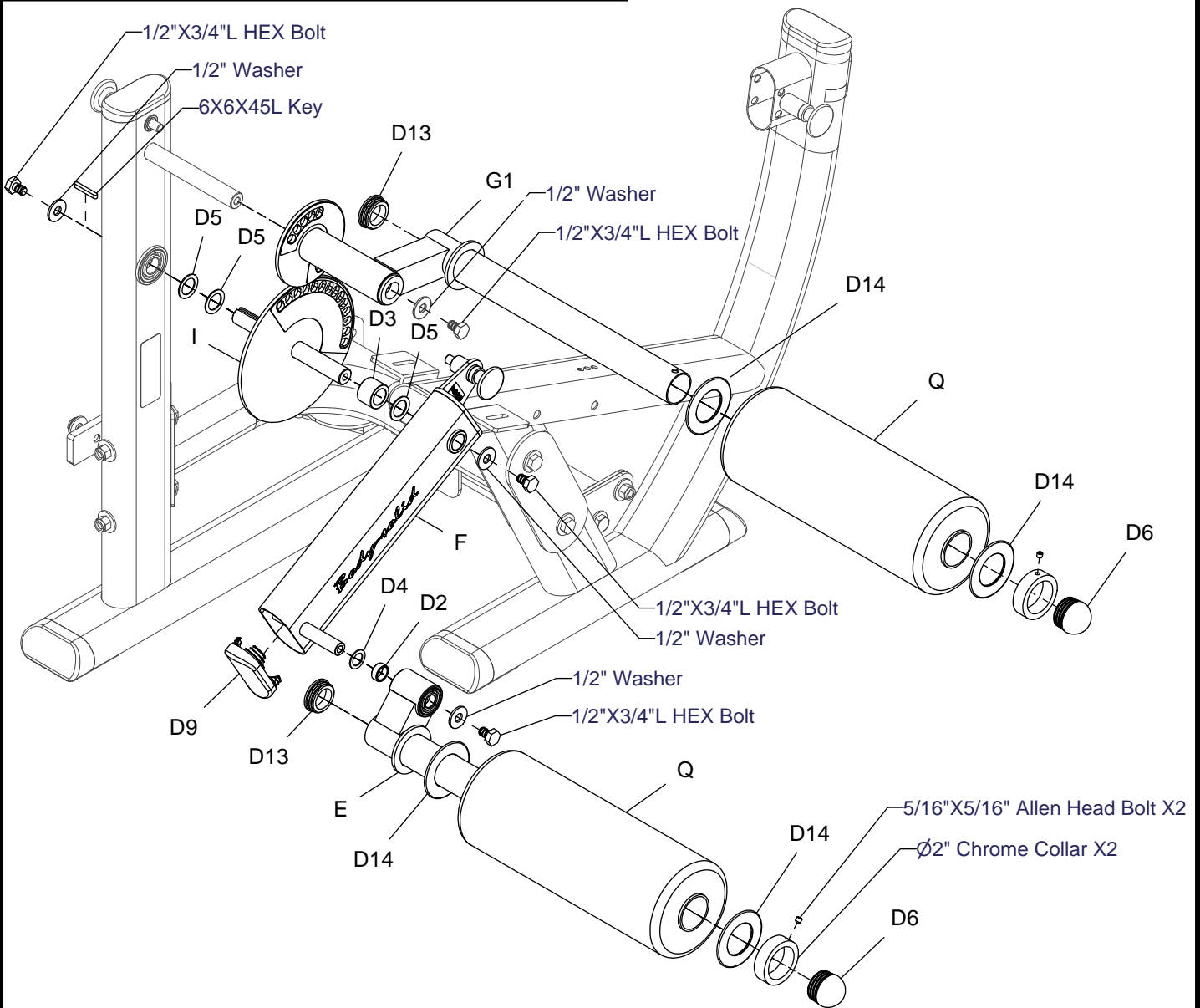

DLEC ASSEMBLY INSTRUCTIONS

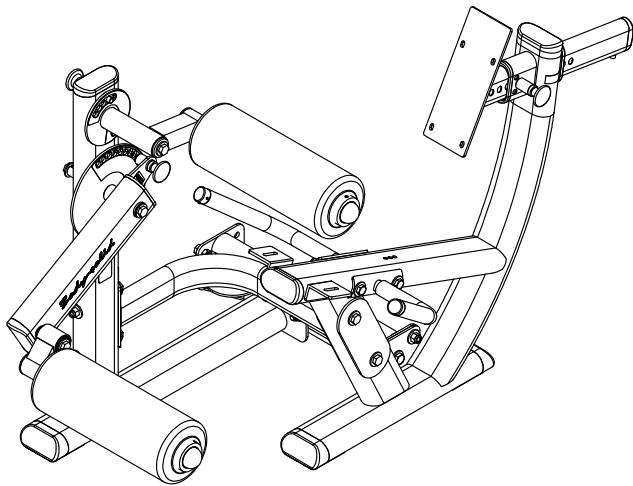

Above shows STEP 4 assembled and completed

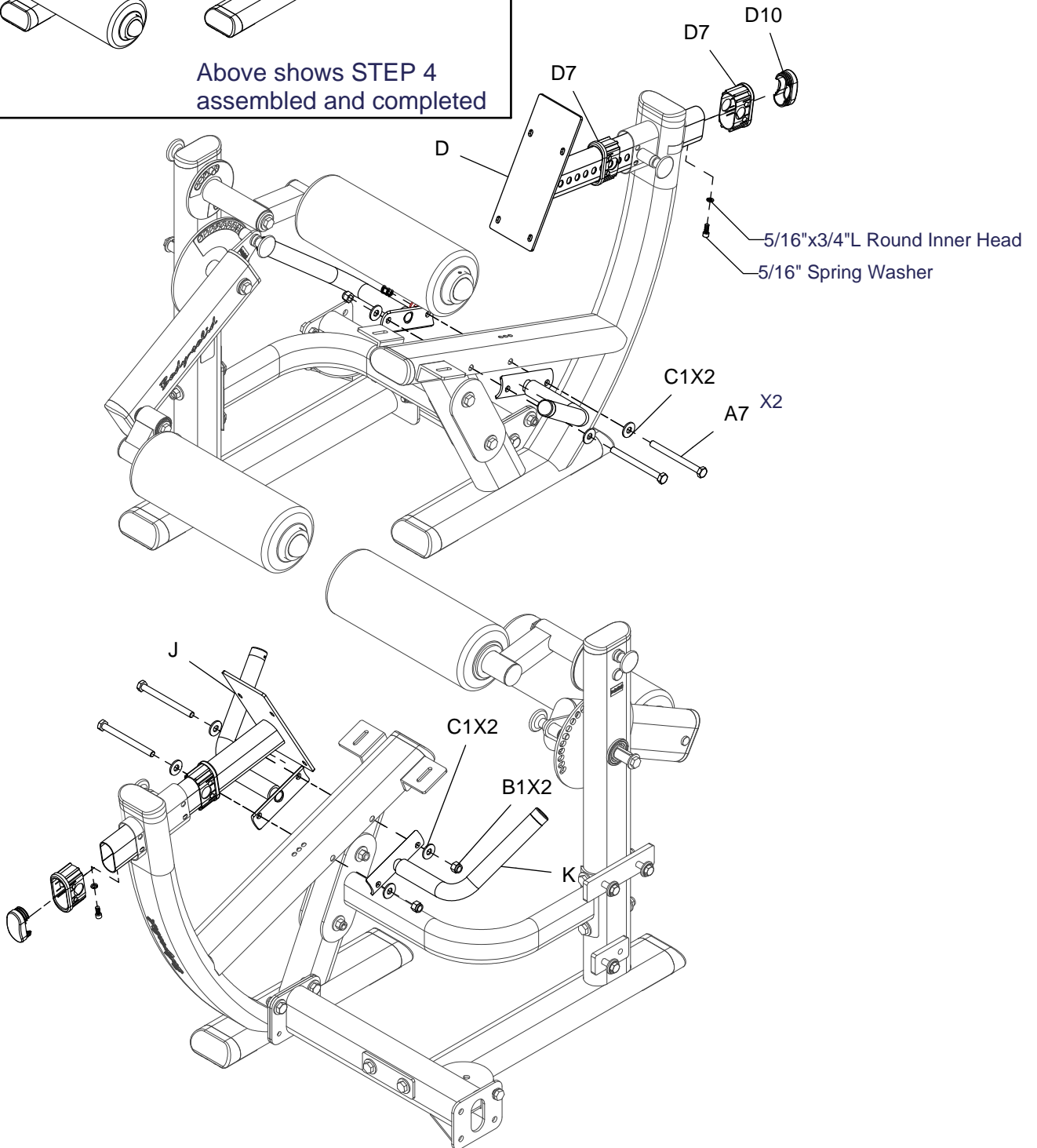

DLEC ASSEMBLY INSTRUCTIONS

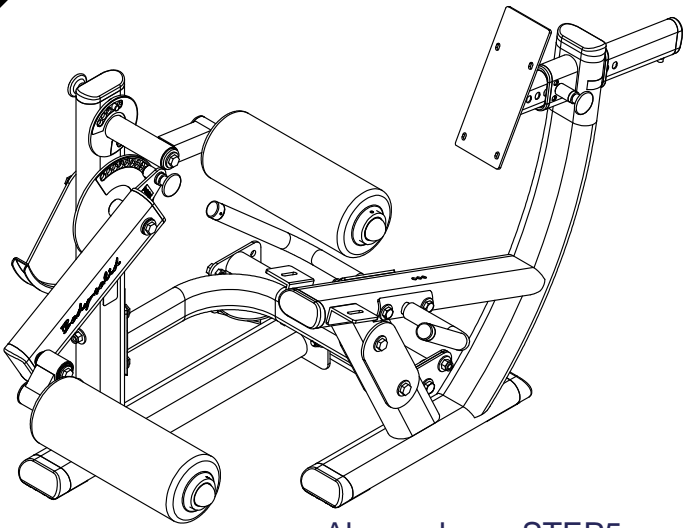

Above shows STEP5 assembled and completed

Detail View

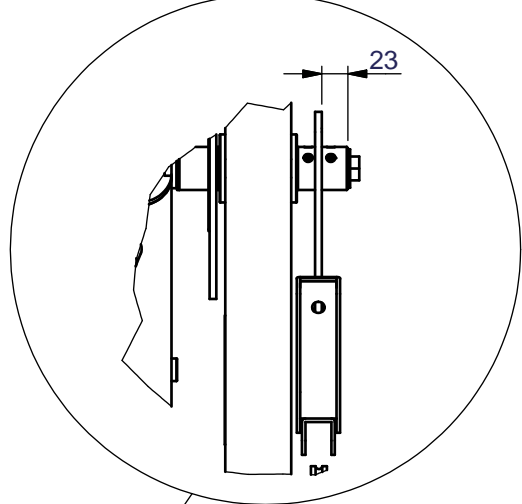

5/16"X5/16"L Allen Head Bolt X4

1/2" Washer X2

1/2"X3/4"L HEX Bolt X2

D11

D12

1/2"X1-1/2"L HEX Bolt X2

1/2" Washer X2

1/2" Round End Cap Washer X2

DLEC ASSEMBLY INSTRUCTIONS

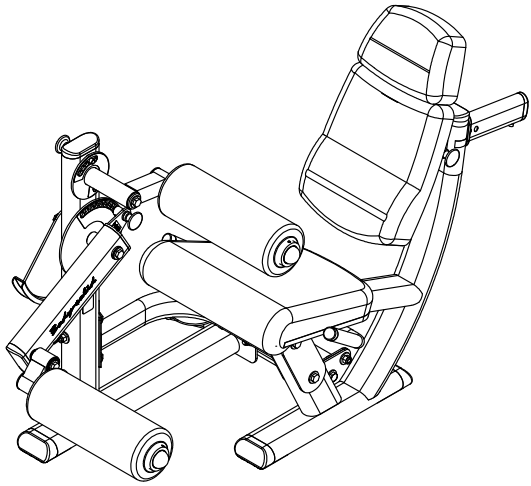

Above shows STEP 6 assembled and completed

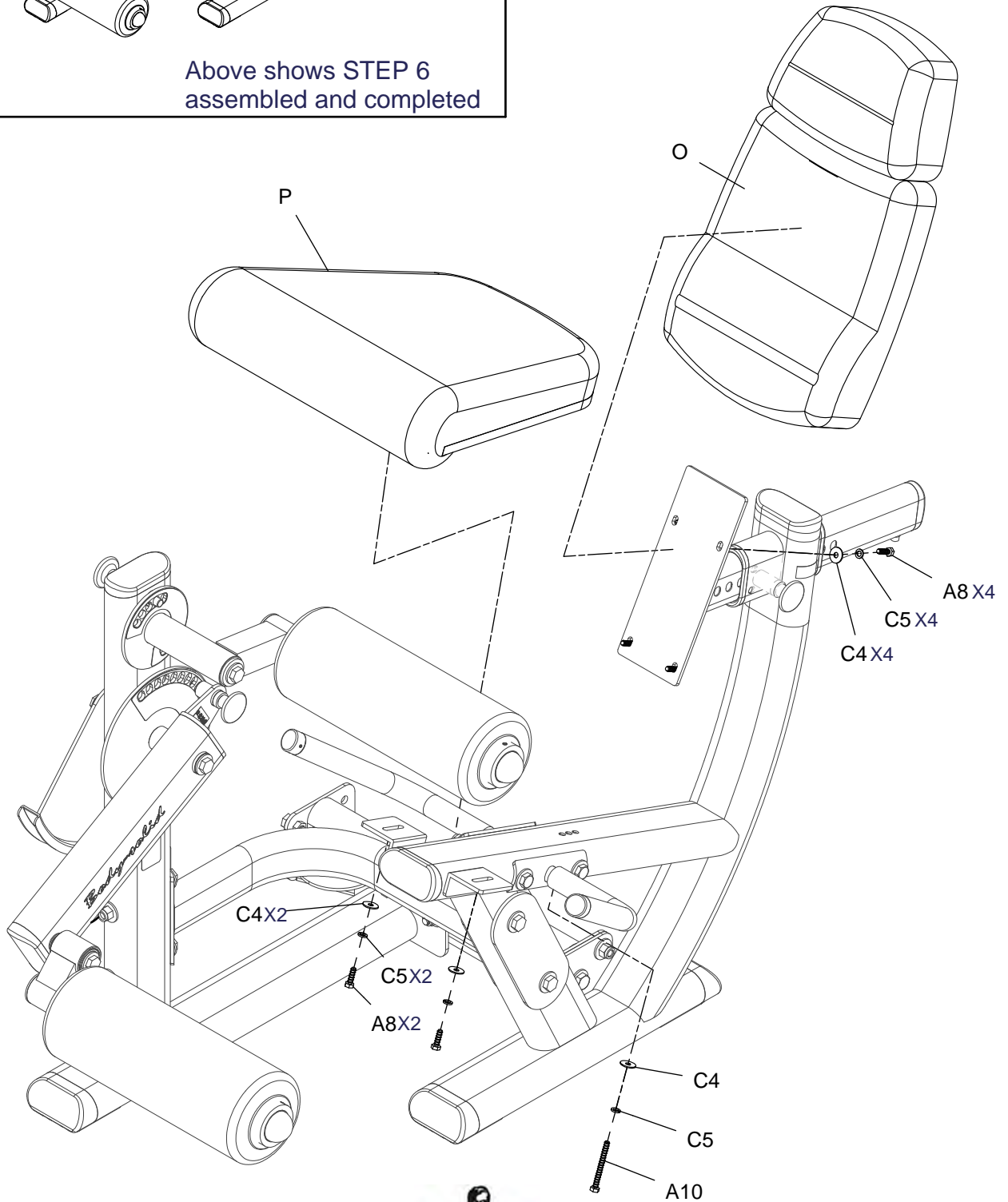

DLEC ASSEMBLY INSTRUCTIONS

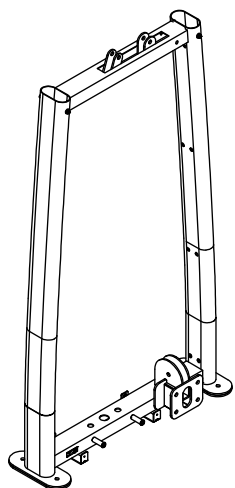

Above shows STEP 7
assembled and completed

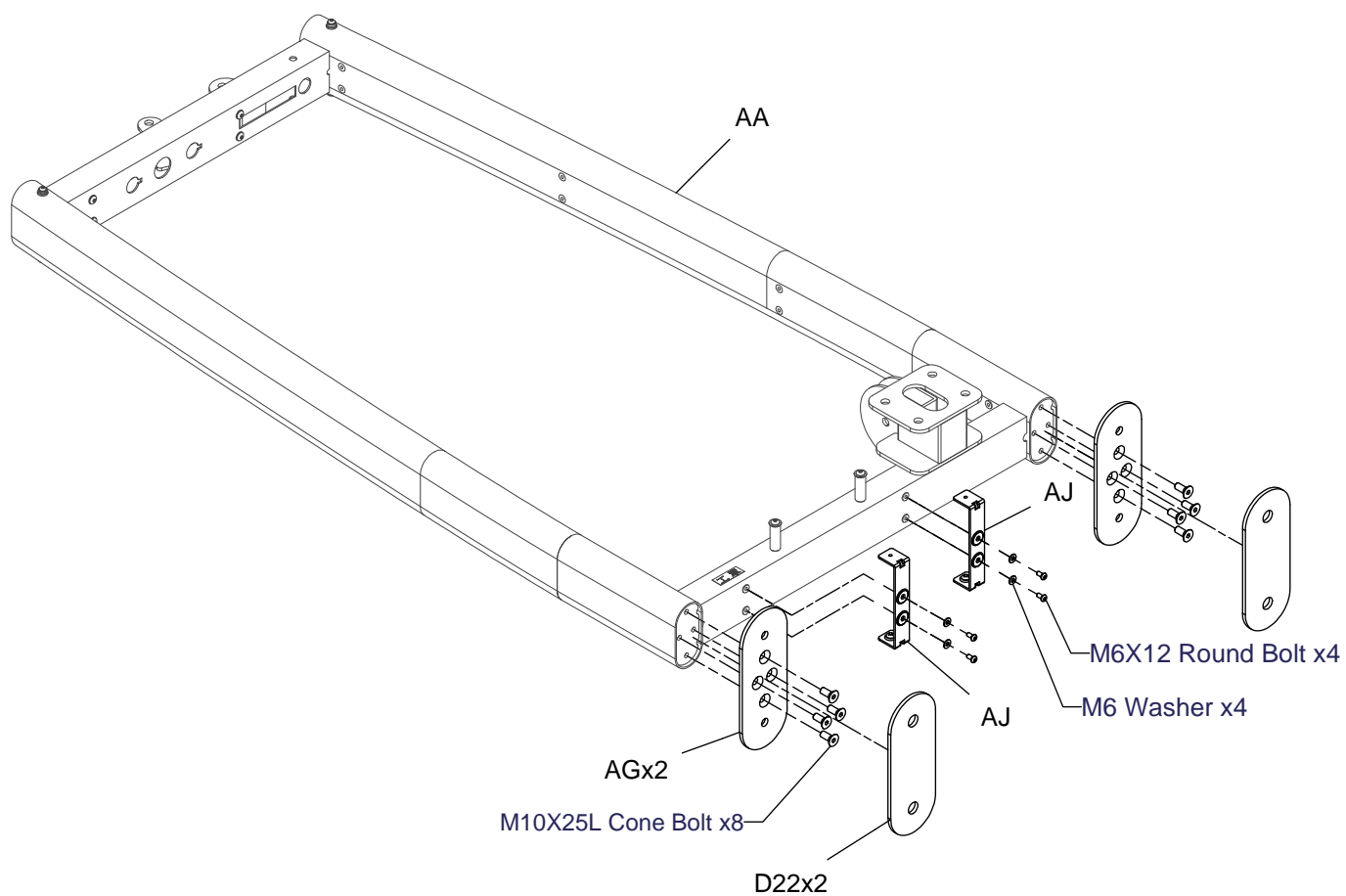

DLEC ASSEMBLY INSTRUCTIONS

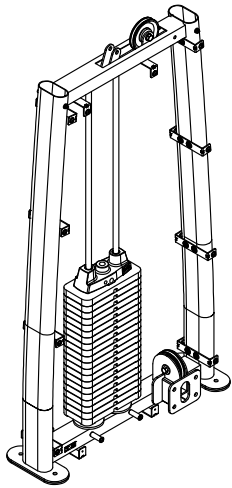

Above shows STEP 8
assembled and completed

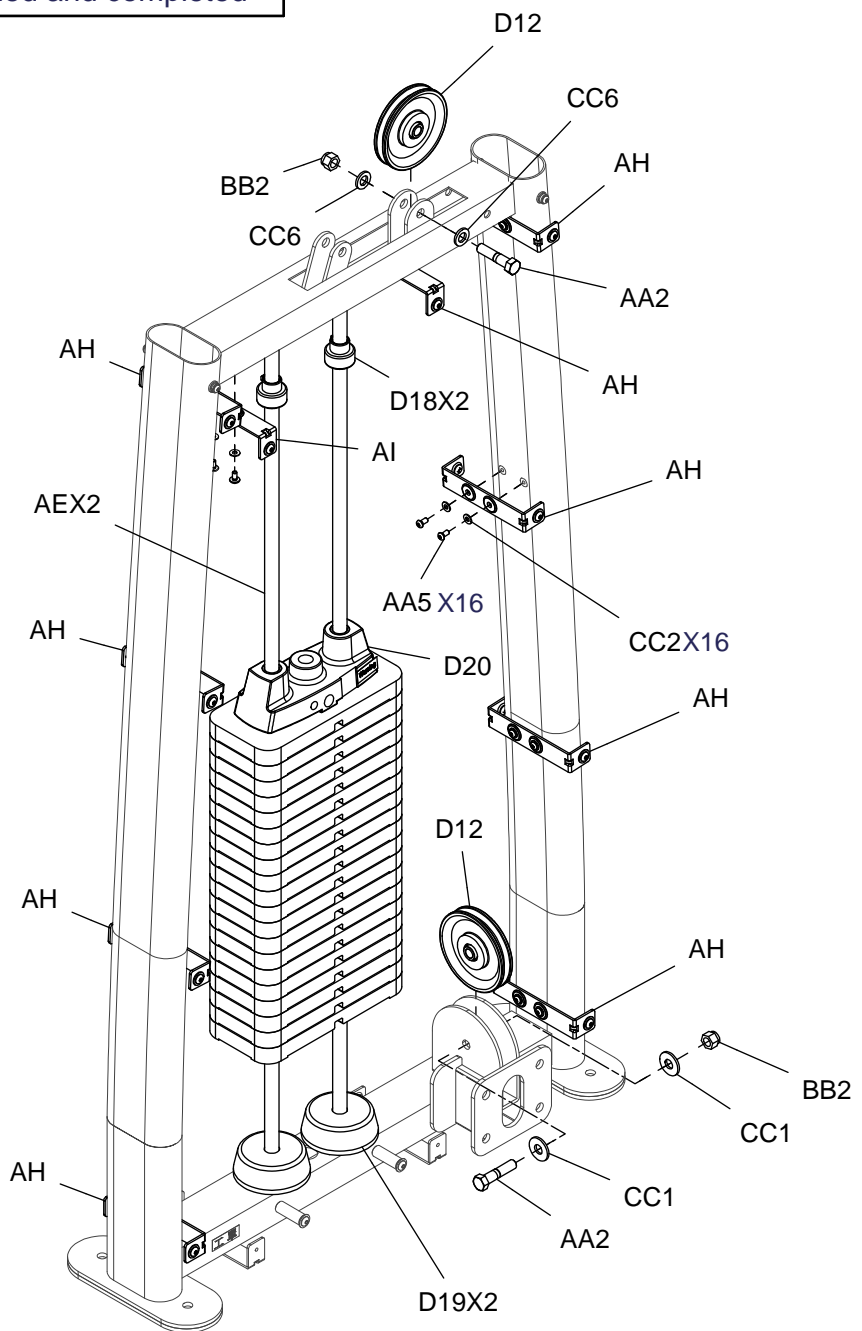

DLEC ASSEMBLY INSTRUCTIONS

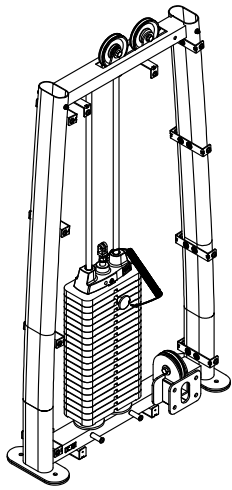

Above shows STEP 9
assembled and completed

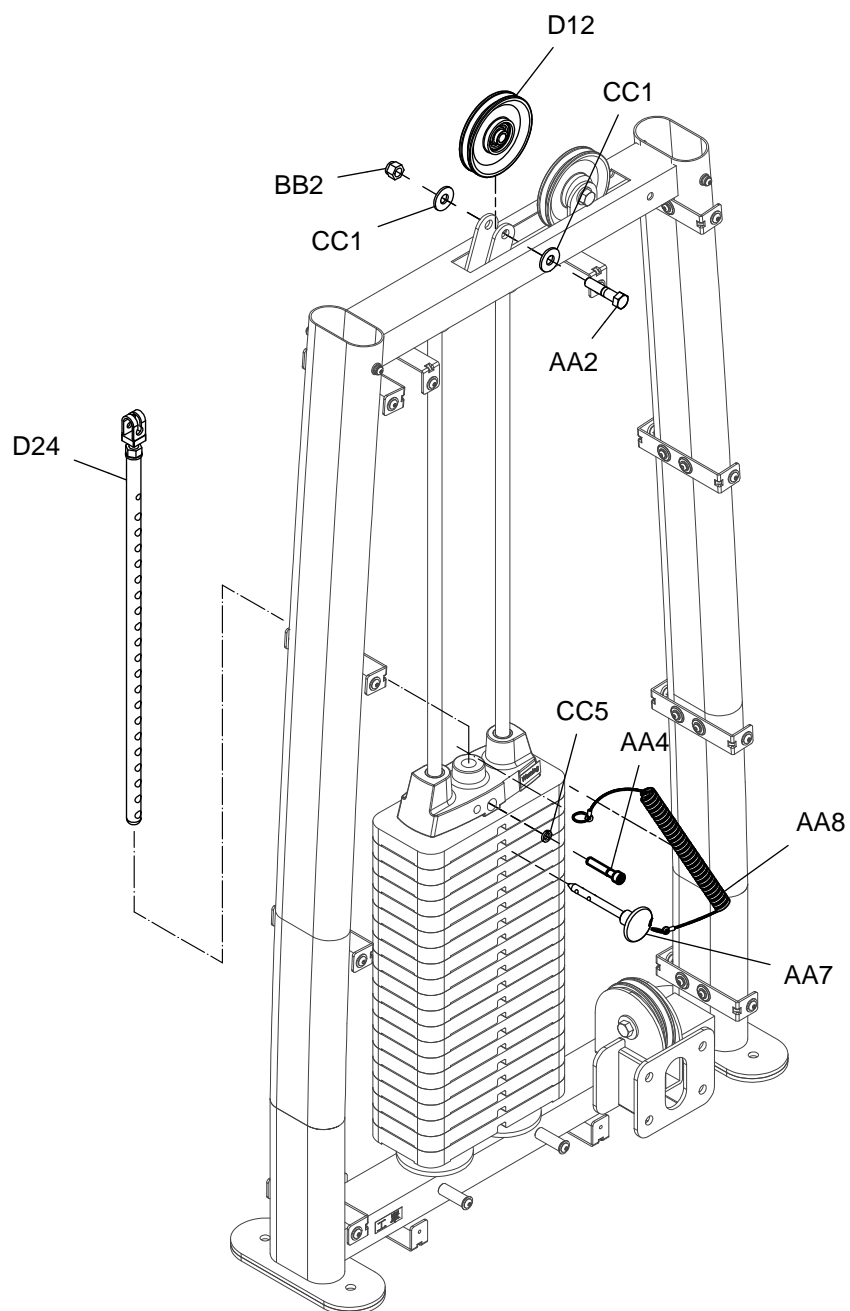

DLEC ASSEMBLY INSTRUCTIONS

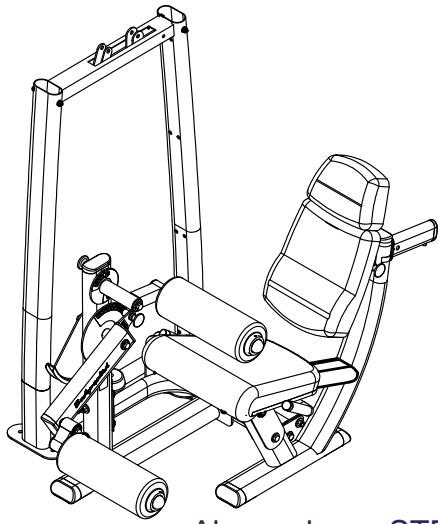

Above shows STEP 10
assembled and completed

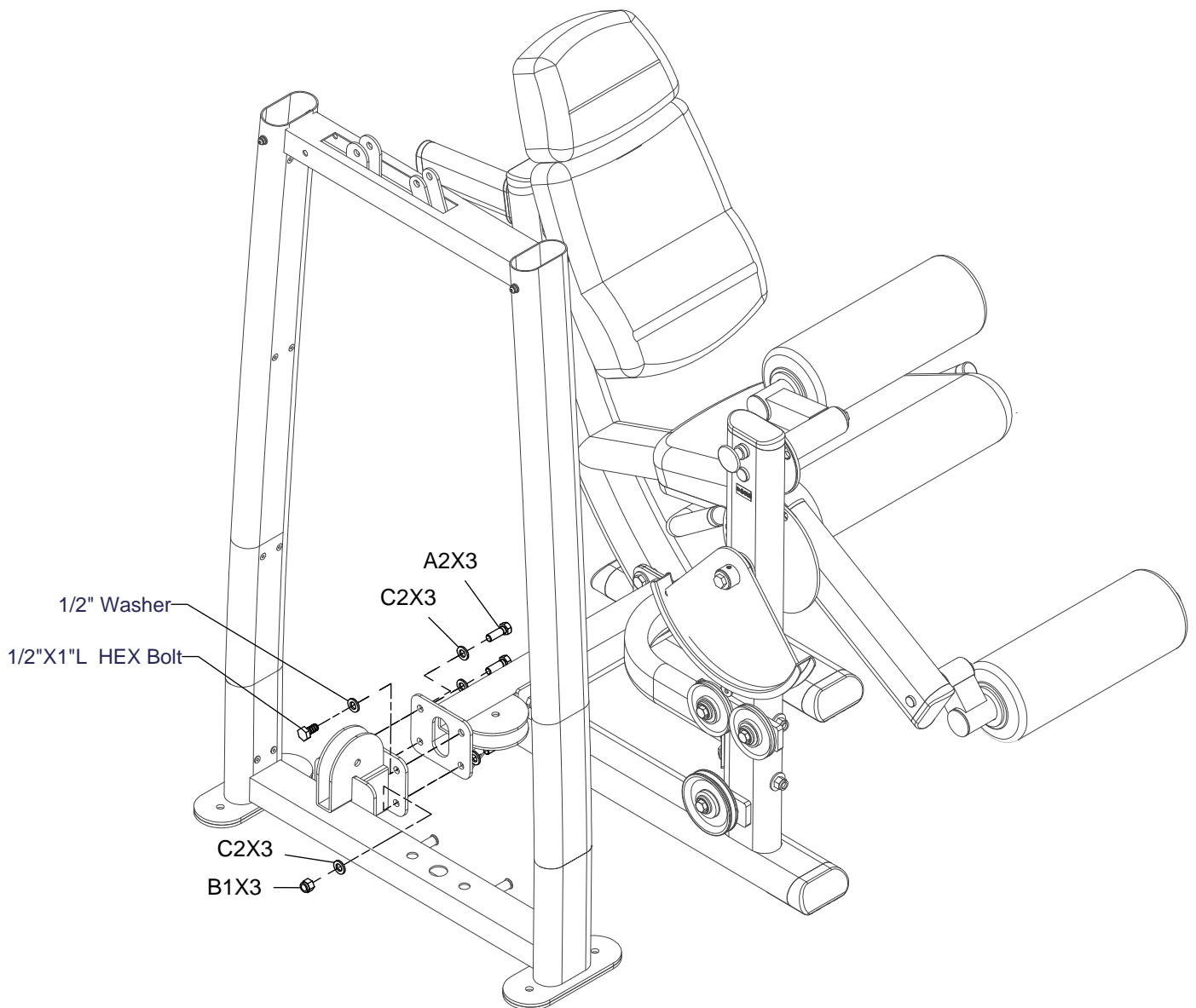

DLEC ASSEMBLY INSTRUCTIONS

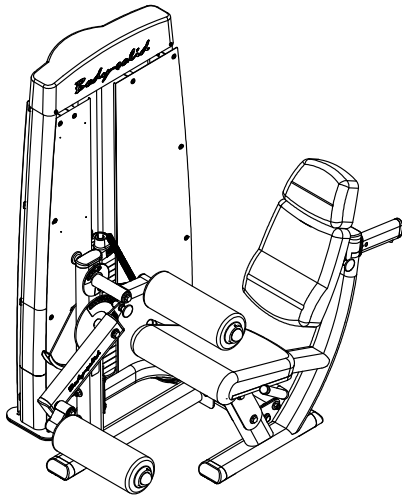

Above shows STEP 11 assembled and completed

D17.



Detail View

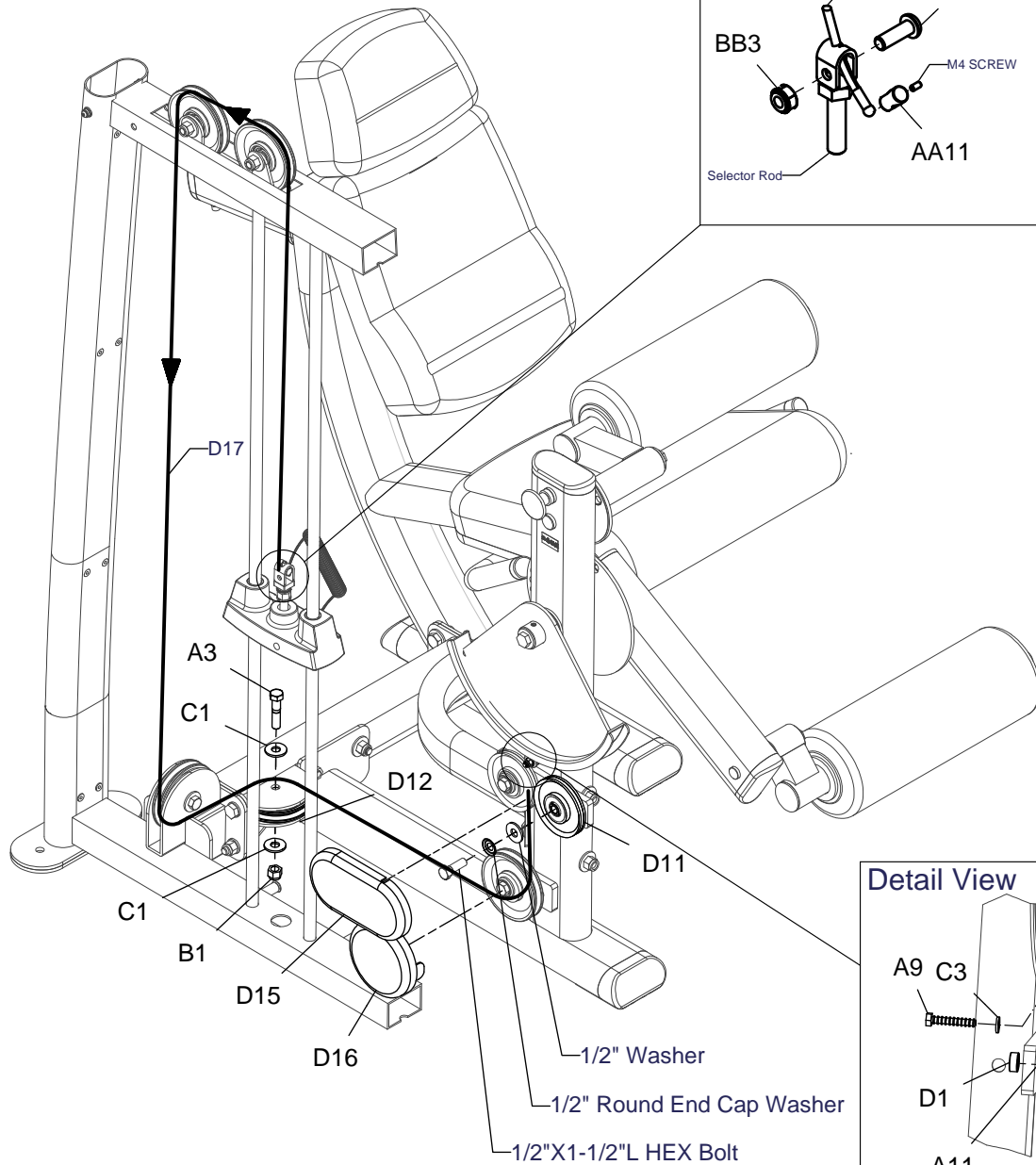
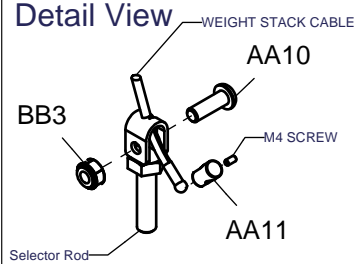

Detail View

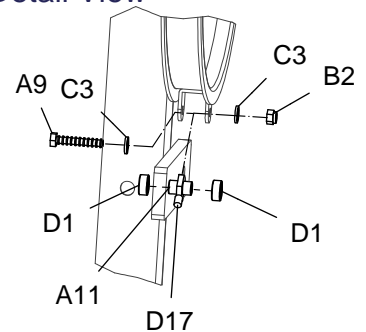

DLEC ASSEMBLY INSTRUCTIONS

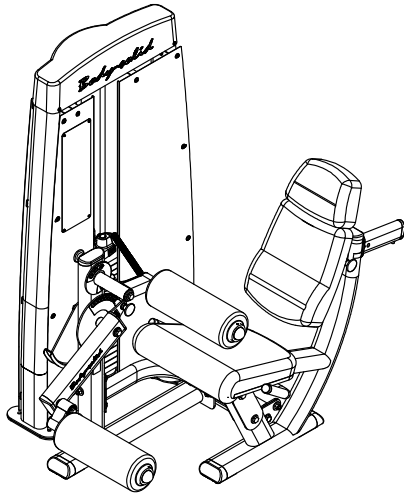

Above shows STEP 12
assembled and completed

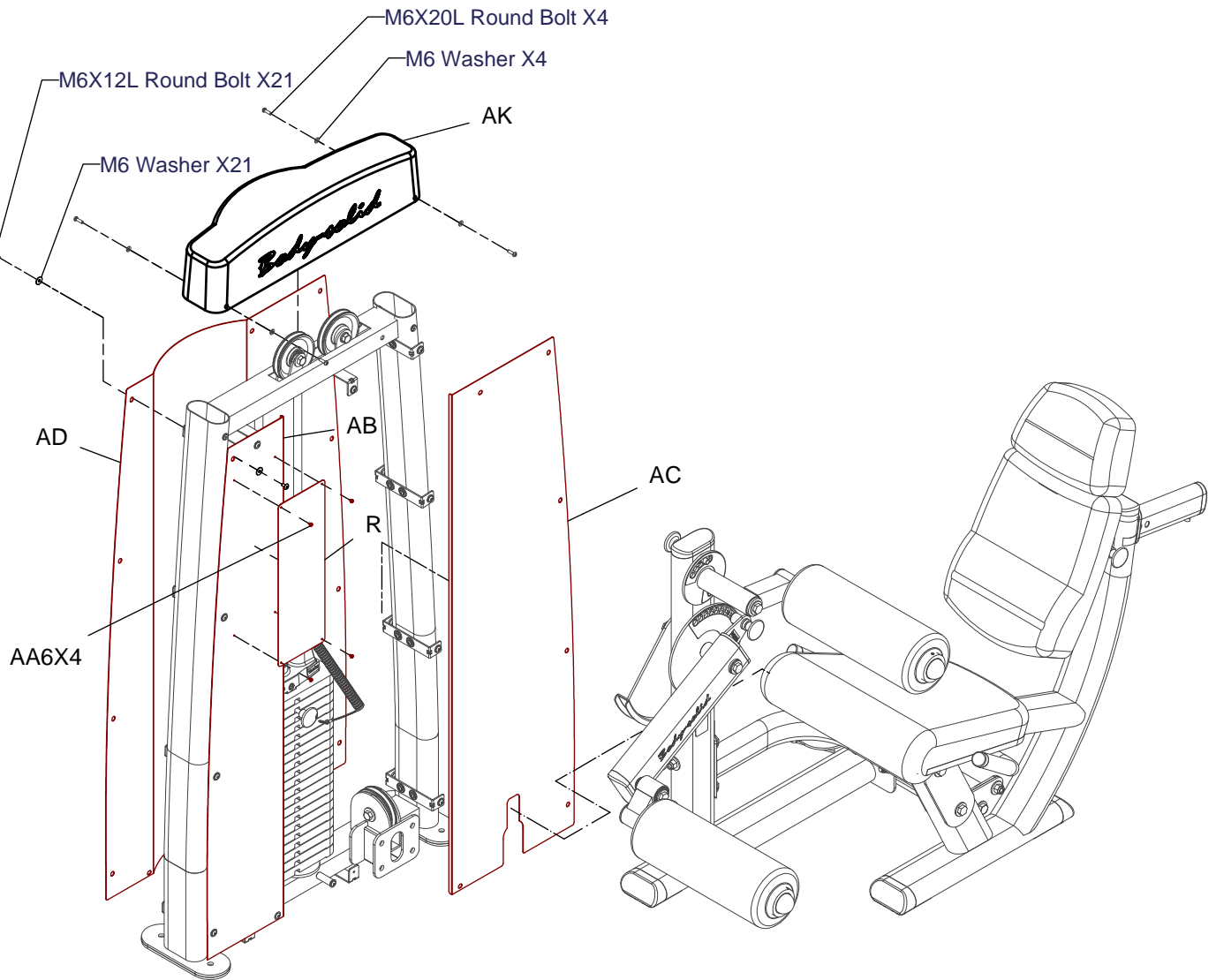

DLEC ASSEMBLY INSTRUCTIONS

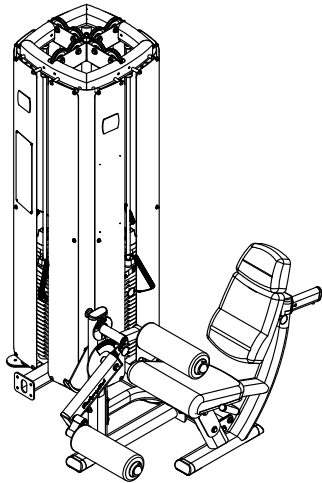

Above shows STEP 13 assembled and completed

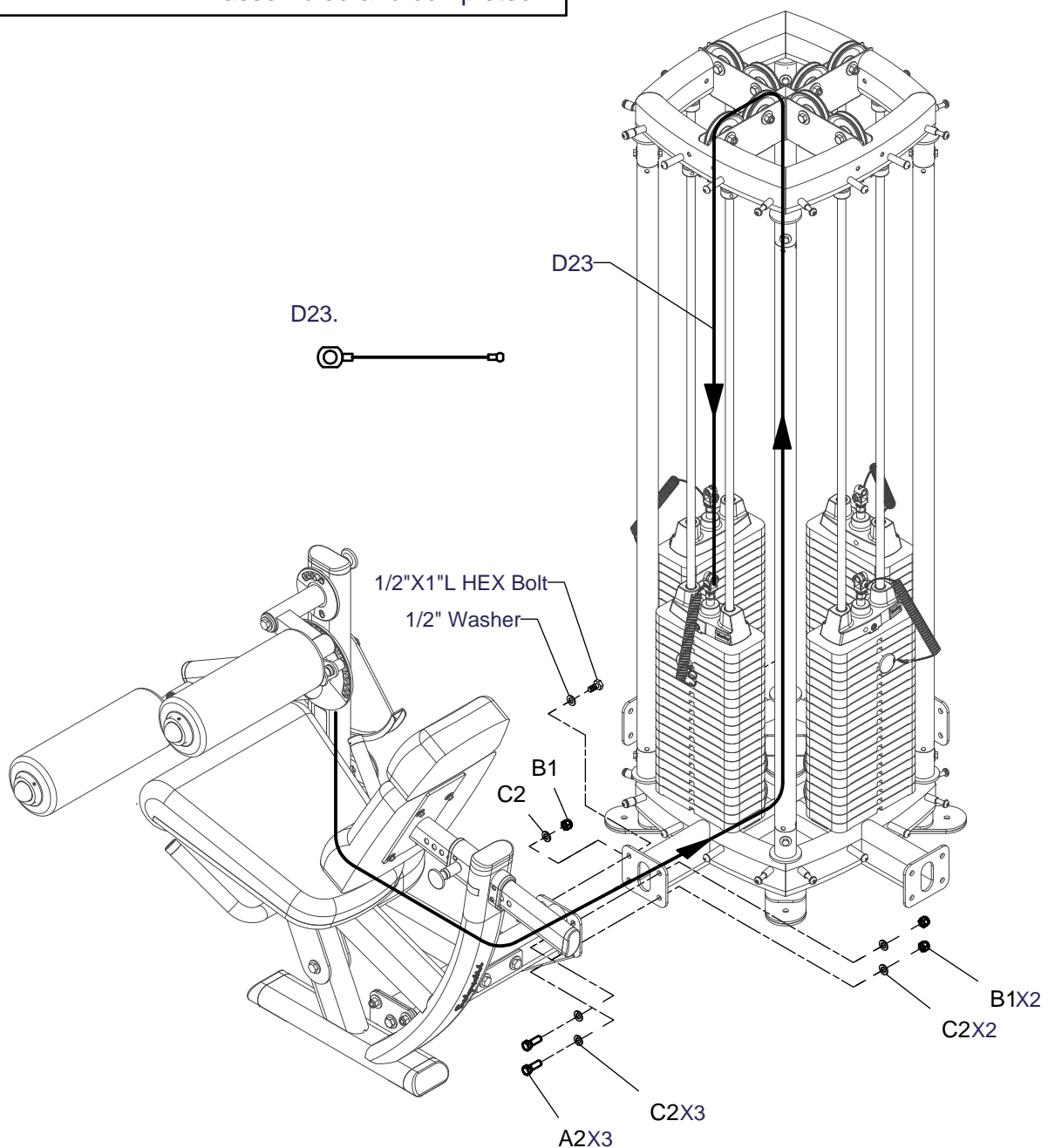

DLEC ASSEMBLY INSTRUCTIONS

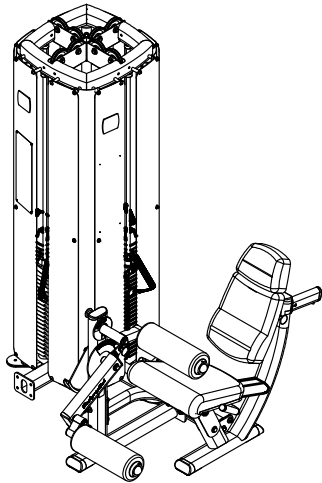

Above shows STEP 13 assembled and completed

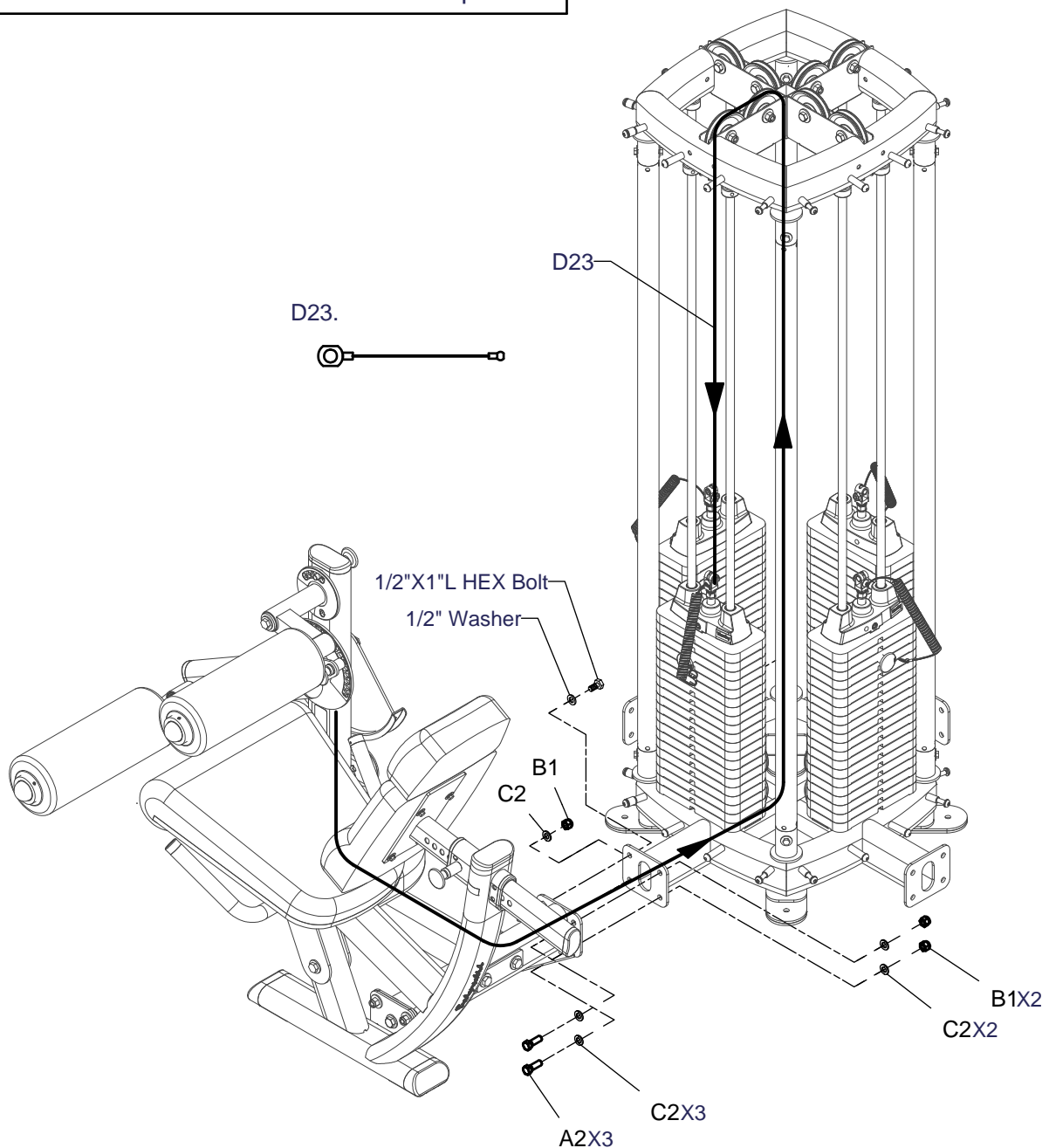

DLEC ASSEMBLY INSTRUCTIONS

