

WE-MAC MANUFACTURING CO.

Quality Steel Storage Tanks Since 1962



CATALOG



TABLE OF CONTENTS

STORAGE TANKS:

Bulk Oil.....	10
Contain-A-Tanks.....	1
Day Tanks.....	4
Double Wall.....	2
Farm Skid Tanks.....	17
Fireguard.....	8
Flameshield.....	2
Generator Base Tank.....	14
Heavy Duty Skid Tanks.....	12
Horizontal.....	6
Oil Tanks.....	10
Oval Basement Tanks.....	11
Overhead Farm Tanks.....	15
Package Fueler.....	3
Pick Up Tanks.....	13
Process Tanks.....	9
Rectangular.....	14
Stands.....	15
Submersible Pump Tanks.....	4
Vertical.....	4
Waste Oil.....	10
Workbench.....	10

ACCESSORIES:

Ball Valves.....	22
Bushings.....	24
Break Aways.....	22
Check Valve.....	7
Couplings.....	24
Decals.....	16
Elbows.....	24
Fill Caps.....	23
Filters.....	23
Fire Valves.....	5
Flanges.....	24
Gate Valves.....	24
Gauge Sticks.....	20
Gauges.....	20
Hi - Low Level Alarms.....	21
Hoses.....	22
Ladders.....	24
Leak Gauge.....	21
Loading Dock.....	11
Nipples.....	24
Nozzles.....	22
Overfill Alarms.....	21
Overfill Prevention Valve.....	21
Plugs.....	24
Placards and Stickers.....	16
Pumps.....	18
Quick Connect.....	24
Solenoid Valves.....	7
Spill Container.....	21
Stands.....	15
Suction Stubs.....	18
Swivels.....	22
Trailers.....	12
Vents.....	23

CALCULATING TANK CAPACITY

RECTANGULAR TANKS:

$L'' \times W'' \times H'' = \text{Cubic Inches}$

$\text{Cubic Inches} / 231 = \text{Gallons}$

(MEASURE IN INCHES)

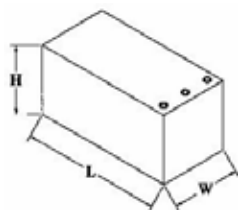

CYLINDRICAL TANKS:

$\text{Dia.}'' \times \text{Dia.}'' \times .7854 \times L'' = \text{Cubic Inches}$

$\text{Cubic Inches} / 231 = \text{Gallons}$

(MEASURE IN INCHES)

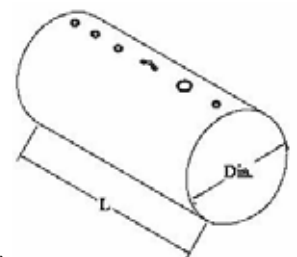

CONTAIN - A - TANK

UL 142 labeled

110% secondary containment

Meets Federal SPCC requirements

Easily relocated, economical installation

Rainshields optional



STORAGE TANK						CONTAINMENT BASIN					
Gallons	Diameter	Length	Gauge	Weight	E.Vent	Length	Width	Height	Gauge	Weight	
300	38"	5'	12 GA	340	3"	84"	48"	20"	12 GA	385	CALL FOR DELIVERED PRICES
550	48"	6'	12 GA	545	4"	94"	72"	21"	10 GA	660	
1,000	64"	6'	10 GA	930	6"	101"	72"	36"	10 GA	970	
1,000	48"	11'	10 GA	1,045	6"	156"	72"	24"	7 GA	1,550	
1,500	64"	9'	7 GA	1,760	6"	138"	96"	30"	7 GA	1,800	
2,000	64"	12'	7 GA	2,200	6"	180"	96"	30"	7 GA	2,200	
2,500	64"	15'	7 GA	2,640	6"	222"	96"	30"	7 GA	2,600	
3,000	64"	18'	7 GA	2,970	6"	240"	96"	36"	1/4"	4,110	
4,000	64"	24'	7 GA	3,900	8"	312"	96"	36"	1/4"	5,300	
4,000	84"	14'	1/4"	4,490	8"	198"	108"	48"	1/4"	4,400	
5,000	96"	13' 6"	1/4"	5,300	8"	204"	132"	48"	1/4"	5,000	
6,000	96"	16'	1/4"	5,970	8"	248"	132"	48"	1/4"	5,750	
8,000	96"	21'	1/4"	7,400	8"	332"	132"	48"	1/4"	7,450	
10,000	96"	27'	1/4"	9,015	8"	420"	132"	48"	1/4"	9,100	
12,000	96"	32'	1/4"	10,400	8"	400"	132"	60"	1/4"	10,500	
15,000	132"	21'	1/4"	11,700	8"	372"	144"	72"	1/4"	11,100	
20,000	132"	28'	1/4"	14,200	8"	495"	144"	72"	1/4"	13,940	

SAVE ON PACKAGE UNITS!



PACKAGE UNITS
300
550
1,000 (64 x 6)
1,000 (4 x 11)
1,500
2,000
2,500

Package Includes:
 Model 701V pump, suction stub, fill cap, gauge, emergency vent, normal vent w/nipple, & 1" plug.
 (Deduct if no pump)

DOUBLE WALL TANKS

UL 142 labeled

Secondary containment

Meets Federal SPCC requirements

Fully-monitorable interstitial space

Easily relocated, economical installation

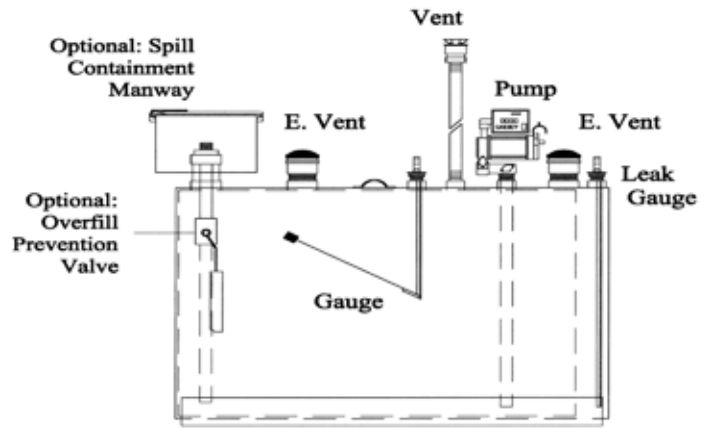

Gallons	Diameter	Length	Inner Tank Gauge	Outer Tank Gauge	Weight	E. Vents*
300	39"	6'	12 GA	12 GA	725	3"
520	49"	6'	12 GA	12 GA	988	4"
1,000	65"	7'	10 GA	12 GA	1,720	6"
1,000	49"	12'	10 GA	12 GA	1,891	6"
2,000	65"	13'	7 GA	10 GA	3,795	6"
2,500	65"	16'	7 GA	10 GA	4,585	6"
3,000	65"	19'	7 GA	10 GA	5,415	6"
4,000	65"	25'	7 GA	10 GA	7,020	8"
4,000	85"	15'	1/4"	10 GA	8,470	8"
5,000	97"	14'	1/4"	10 GA	8,900	8"
6,000	97"	17'	1/4"	10 GA	9,510	8"
8,000	97"	22'	1/4"	10 GA	11,490	8"
10,000	97"	28'	1/4"	10 GA	14,240	8"
12,000	97"	33'	1/4"	10 GA	16,645	8"
15,000	133"	22'	1/4"	7 GA	20,300	8"
20,000	133"	29'	1/4"	7 GA	24,900	8"

CALL FOR DELIVERED PRICES

* -- Double Wall tanks require 2 emergency vents.



Package Price Includes:

- Normal vent with nipple
- Qty. 2 emergency vents per tank
- Level Gauge and Fill Cap
- Krueger Leak Gauge
- Fill-Rite 701V pump with suction stub (deduct if no pump)

Optional Accessories:

- ** Overfill Prevention Valve
- ** Spill Containment Manway
- ** Waste Oil Box



- * Double Wall Secondary Containment Tanks
- * 2-hour 2000° fire-test by Southwest Research Institute to SwRI 97-04
- * Horizontal, vertical, cylindrical, and rectangular designs available
- * 30 year warranty

PACKAGE FUELER



DOUBLE WALL SECONDARY CONTAINMENT TANK

**Plug-In
&
Fuel!**

*Quick Delivery
Available*

*Factory Installed
Accessories*

PACKAGE FUELER INCLUDES:

Fill-Rite FR313V High Speed Pump

Fill-Rite FR902CRU Remote Dispenser

High Flow Filter Head and Element

20' Hose with Break-Away

High Flow Automatic Nozzle w/ Swivel

515 Spill Container for Fill

Fill Assembly w/ Ball Valve, Check Valve, & Quick Connect

Clock Gauge with Alarm

Emergency Vents

Normal Vent with Nipple

Diesel and No Smoking Decals

All Accessories Factory Installed

AVAILABLE IN ALL SIZES!

Most Popular Sizes:

10,000 Gallon 8' dia x 28' Double Wall
and

12,000 Gallon 8' dia x 33' Double Wall



VERTICAL STORAGE TANKS

- * UL 142 Labeled
- * Backwelding available for fertilizer tanks
- * Double wall tank bottoms available
- * Heaters and insulation also available

SINGLE WALL

1/4" Bottom	1/4" Bottom
7 GA Shell	1/4" 1st Ring
10 GA Cover	7 GA Shell
	10 GA Cover

DOUBLE WALL

INNER	OUTER	INNER	OUTER
1/4" Bottom	1/4" Bottom	1/4" Bottom	1/4" Bottom
7 GA Shell	10 GA Shell	1/4" 1st Ring	7 GA 1st Ring
10 GA Cover		7 GA Shell	10 GA Shell
		10 GA Cover	

Single Wall Vertical Tanks				
Gallons	Dimensions	Weight	Weight	E. Vent
2,110	6' x 10'	2,012		6"
2,530	6' x 12'	2,298		6"
3,005	8' x 8'	2,629		6"
3,760	8' x 10'	3,003		6"
4,000	8' x 11'	3,190		8"
5,600	8' x 15'	3,785		8"
5,800	10' x 10'	4,000		8"
6,000	8' x 16'	4,040		8"
7,050	10' x 12'	4,440		8"
8,800	10' x 15'	5,185		8"
10,000	10' x 17'	5,680		8"
12,000	11' x 17'	6,440		8"
15,000	12' x 18'	7,510		8"
16,900	12' x 20'	8,330		8"
20,000	12' x 24'	10,175		10"
25,000	12' x 30'		11,910	10"
30,000	12' x 35'		14,500	10"

Double Wall Vertical Tanks		
Weight	Weight	E. Vents
3,650		6"
4,150		6"
4,400		6"
5,100		6"
5,445		8"
6,500		8"
6,737		8"
7,200		8"
7,618		8"
8,953		8"
9,830		8"
11,022		8"
12,953		8"
14,403		8"
16,572		10"
	20,222	10"
	24,850	10"

REMOTE TANK FOR SUBMERSIBLE PUMP

REMOTE TANK			
Stock #	Gallons	Gauge	
2016	150	7 ga.	

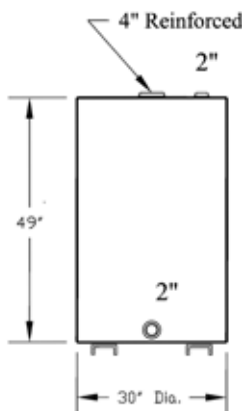

INSPECTION RINGS

6" Beams

INSPECTION RINGS		
Stock #	Tank Diameter	
2017	8'	
2018	10'	
2019	11'	
2020	12'	

Comply w/Federal SPCC tank inspection requirements by installing these rings under all of your vertical tanks.



AST BULK STORAGE

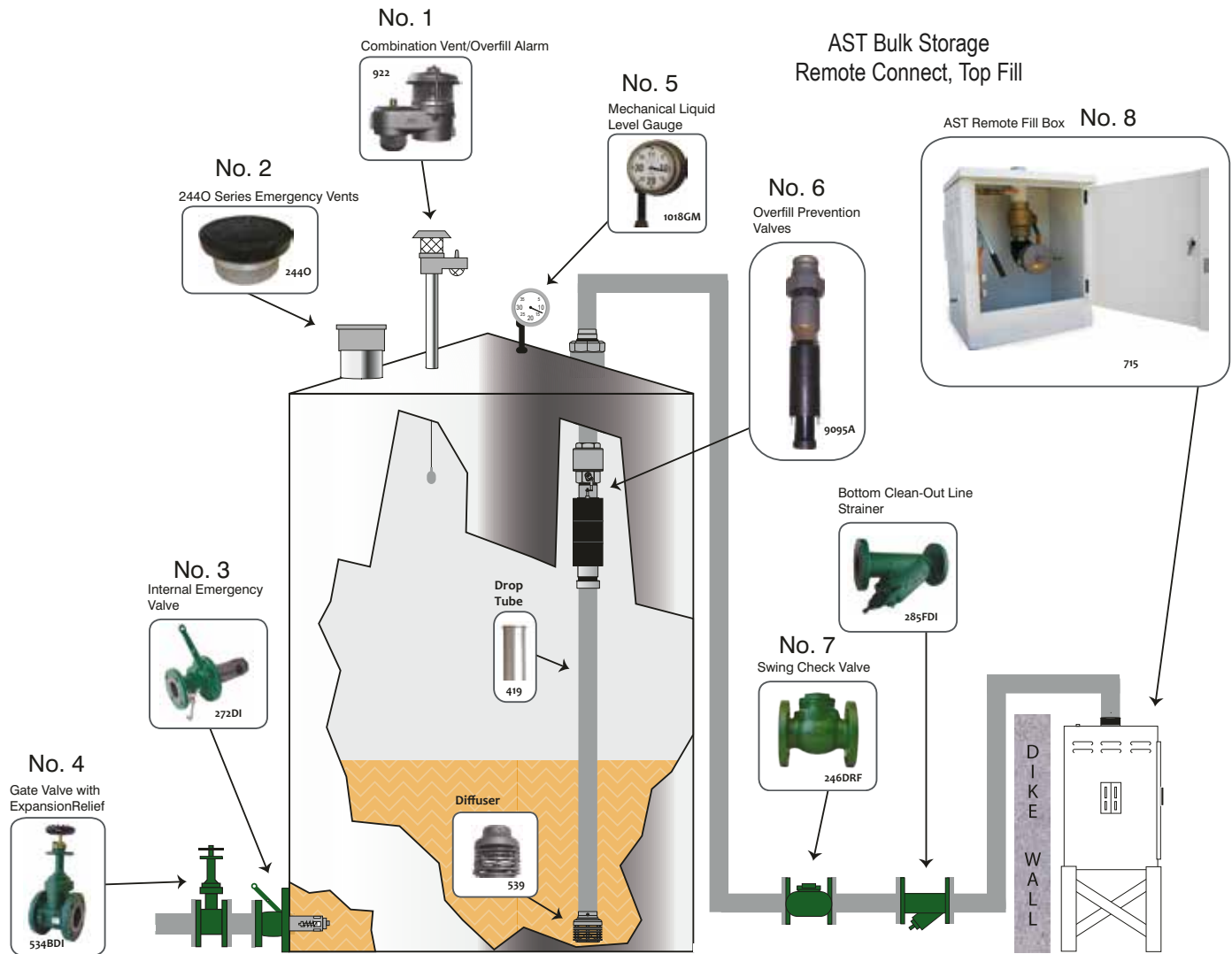

No.	Part #	Description
1	7582	2" 748A Pressure Vacuum Vent
1	7920	2" 922 Pressure Vacuum Vent with Overfill Alarm
1	7583	3" 748A Pressure Vacuum Vent
1	7921	3" 922 Pressure Vacuum Vent with Overfill Alarm
2	7776	6" 244OM Emergency Vent -- Male Threaded
2	7778	8" 244OM Emergency Vent -- Male Threaded
2	7781	10" 244F Emergency Vent -- Flanged w/ bolts, nuts, gasket
3	8227	2" 272HDI Internal Emergency Valve "Fire Valve"
4	8228	2" 535BDI Locking Gate Valve with Expansion Relief
5	8229	1018GM Mechanical Tank Gauge, 35' Maximum Level
6	7925	2" 9095A Overfill Prevention Valve
7	8226	2" 246ADI Swing Check Valve
8	7942	715 Remote Spill Container w/ Dry Disconnect and Ball Valve
8	7938	515 Remote Spill Container w/ no accessories (on pedestal)

See Pages 20 and 23 for additional gauges and vents.

SINGLE WALL HORIZONTAL TANKS



* Single Wall Tanks

Optional Porch and Rainhood

* UL 142 labeled

Horizontal Storage Tanks					
Gallons	Diameter	Length	Gauge	Weight	E. Vent
3,000	64"	18'	7 GA	2,970	6"
3,000	6'	14'	7 GA	2,700	6"
4,000	64"	24'	7 GA	3,900	8"
4,000	6'	19'	7 GA	3,700	8"
4,000	7'	14'	1/4"	4,490	8"
5,000	8'	13' 6"	1/4"	5,300	8"
6,000	8'	16'	1/4"	5,970	8"
8,000	8'	21'	1/4"	7,400	8"
8,000	9'	17'	1/4"	7,200	8"
10,000	8'	27'	1/4"	9,015	8"
10,000	9'	21'	1/4"	8,500	8"
10,000	10'	17'	1/4"	8,300	8"
12,000	8'	32'	1/4"	10,400	8"
12,000	9'	25'	1/4"	9,800	8"
15,000	11'	21'	1/4"	10,300	8"
20,000	11'	28'	1/4"	13,200	8"



Available with 6" saddles or full length skids



For horizontal tanks less than 3,000 gallons -- see page 17

ABOVE GROUND FUEL STORAGE SYSTEM

with remote fill and side mounted dispenser

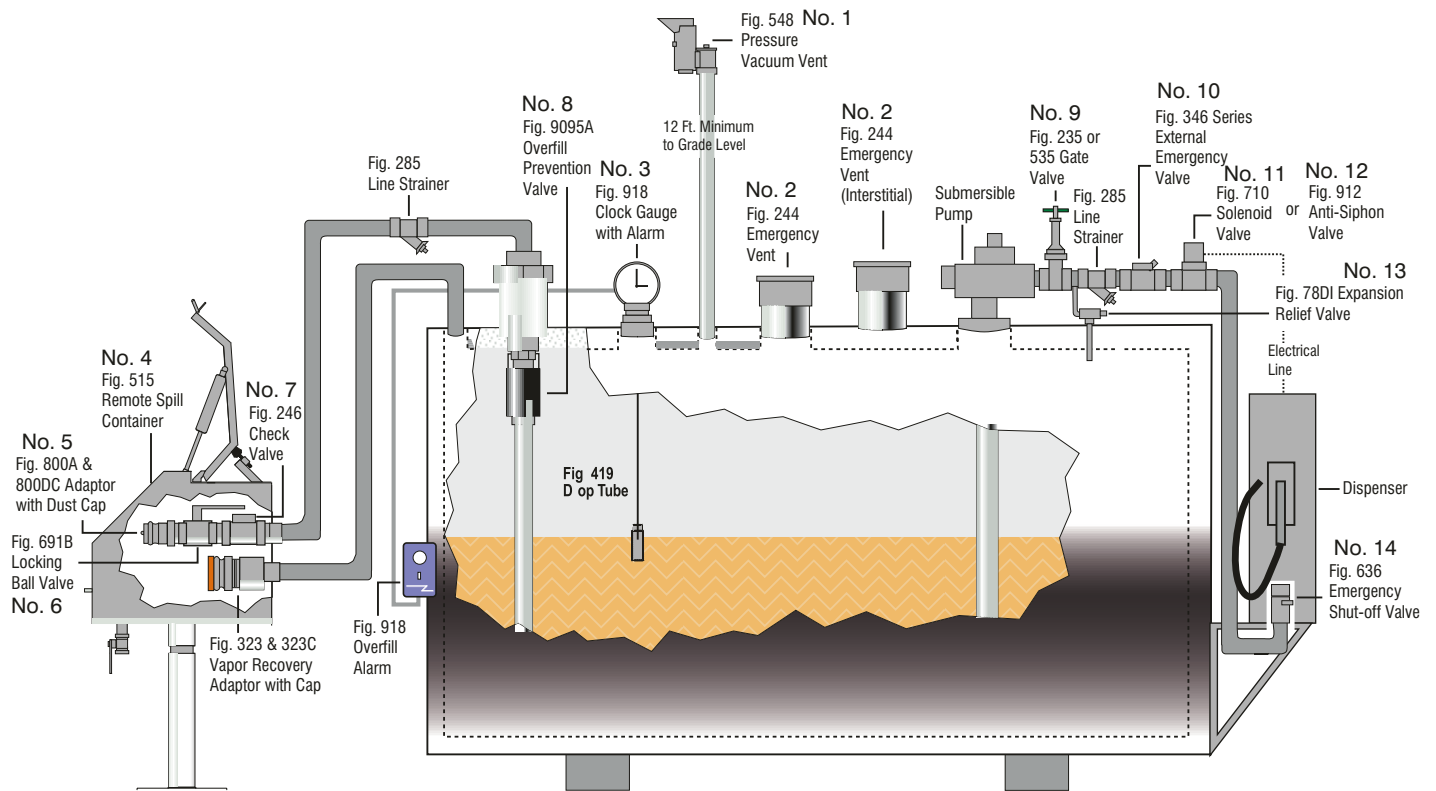

No.	Stock #	Description	No.	Stock #	Description
1	7582	2" Pressure Vacuum Vent - 748A	6	7928	2" Locking Ball Valve - 691B
1	7583	3" Pressure Vacuum Vent - 748A	7	8226	2" Swing Check Valve - 246
2	7776	6" Emergency Vent -- Male	8	7925	2" Overfill Prevention Valve
2	7778	8" Emergency Vent -- Male	9	8219	1 1/2" Gate Valve - 235
2	7781	10" Emergency Vent -- Flanged	10	8220	1 1/2" External Emergency Valve - 346
3	7900	Clock Gauge - 818	11	8221	1 1/2" Solenoid Valve
3	7901	Clock Gauge w/ Alarm - 918	12	8230	Anti-Siphon Valve - 912
4	7938	2" Remote Spill Container - 515	13	8222	1/2" Expansion Relief Valve - 78DI
5	8224	2" Adapter w/ Dust Cap - 800	14	8225	2" Emergency Shutoff Valve - 636

See Pages 20, 21 and 23 for additional vents, gauges, and overfill prevention

OPTIONAL STAIRS



OPTIONAL LADDERS



OPTIONAL SHELVES



FIREGUARD - Fire Rated Tanks

UL 2085 Labeled

2 hour fire rating

30 year warranty

- * UL 2085 Listed "Protected" tank
- * Ballistics and Impact protection per UL 2085
- * Lightweight thermal insulation material exceeds UL 2 hour fire test
- * Insulating material is 75% lighter than concrete
- * Meets National Fire Protection Association (NFPA) 30 & 30A
- * Meets International Fire Code (IFC)
- * Meets California Air Resources Board (CARB) testing requirements
- * Meets STI F941 for Thermally Insulated Aboveground Storage Tanks

Cylindrical					
Gallons	Diameter	Length	Weight	E. Vents	
300	50"	6'	2,400	4"	
500	54"	6'	3,100	4"	
1,000	70"	7'	3,800	6"	
1,000	54"	12'	3,900	6"	
2,000	70"	13'	6,500	6"	
3,000	78"	15'	9,700	6"	
4,000	78"	20'	12,000	8"	
4,000	90"	15'	12,300	8"	
5,000	102"	14'	13,800	8"	
6,000	102"	17'	15,500	8"	
8,000	102"	22'	20,000	8"	
10,000	102"	28'	24,500	8"	
12,000	102"	33'	28,000	8"	
15,000	138"	22'	35,000	8"	
20,000	138"	29'	43,500	8"	



*Cylindrical
- or -
Rectangular*

Rectangular					
Gallons	Length	Width	Height	Weight	E. Vents
300	66"	48"	48"	2,800	4"
500	80"	60"	48"	4,100	4"
1,000	102"	60"	54"	4,300	6"
2,000	138"	72"	60"	6,300	6"

(larger sizes available)



SPECIAL PROCESSING TANKS



BATCH TANKS



MIX TANKS

Call us for all of your industrial applications!

*Serving a wide range of industries including:
paint, ink, cosmetic, and lube*



BULK STORAGE



HEATING COILS



INSULATED TANKS



WATER JACKETS



CALIBRATION TANKS

OIL TANKS



WASTE OIL TANKS

- * U.L. 142 Listed
- * 12" deep filter box allows complete filter drainage
- * Eliminates expensive oil spills
- * Eliminates messy drums
- * Provides secondary containment
- * Portable

Stock#	Gallons
4300	150
4301	300
4302	550
4303	1000 (4x11)

VERTICAL BULK OIL TANKS



- * U.L. 142 Listed

Stock#	Gallons	Size
4304	300 Gallon SINGLE WALL	38" dia x 61"
4305	550 Gallon SINGLE WALL	48" dia x 72"
4315	1,000 Gallon SINGLE WALL	64" dia x 72"
4306	300 Gallon DOUBLE WALL	39" dia x 61"
4307	550 Gallon DOUBLE WALL	49" dia x 72"
4317	1,000 Gallon DOUBLE WALL	65" dia x 72"

WORKBENCH TANKS

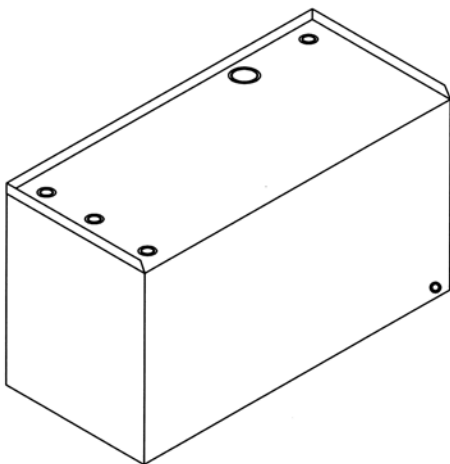

- * U.L. 142 Listed
- * 2" Spill Lip around sides and back
- * Custom sizes available

Stock#	Gallons	Size
4308	300 Gal	60" L x 36" W x 32" H
4309	475 Gal	72" L x 48" W x 32" H

OVAL BASEMENT TANKS



2276
Style B
(Most Popular)



Stock #	Description
2275	275 Oval Tank - 14 ga 27 1/2" Width - 44" Height - 60" Length 3-2" top openings 1-1" outlet Four mounting brackets for 1 1/4" pipe legs
2280	275 Oval with reel bracket
2281	275 Oval Tank - Vertical
2276	275 Oval - Style B
2277	275 Oval - Style B with reel bracket
2285	330 Oval Tank - 12 ga 27 1/4" width - 44" height - 72" length
2287	330 Oval - Style B
2290	1 1/4" x 8" Pipe Legs (set of 4)
7140	Basement Tank Gauge
7902	Golden Gauge (reads in gallons)
7400	2" Fill Cap

CONTAINMENT BASIN FOR OVAL TANK

4649	66" L x 32" W x 36" H (Dike Only)
------	-----------------------------------

BULK PLANT LOADING DOCK

- Toe Plates
- Stair Steps
- 2 Hand Rails
- Skywalk Grating
- 5' x 10' Platform
- 6' High Platform
- Double Guard Rails on Sides and Back

Stock#	Description
9200	Bulk Plant Loading Dock
9210	Opt. Control Rod w/Brackets (each)
9220	Opt. Counter Balance Kit (each)



PORTABLE FUEL TANKS

TANK ON TRAILER

- * Includes Lights and Brakes – D.O.T. Trailer
- * No D.O.T. Label on Tank
- * Custom Sizes Available



Stock#	Description
6340	550 Gallons
6345	1,000 Gallons

Prices include Tank and Trailer

HEAVY DUTY SKID TANKS FOR TRAILERS

- * No D.O.T. Label

2" Reinforced

2" Reinforced

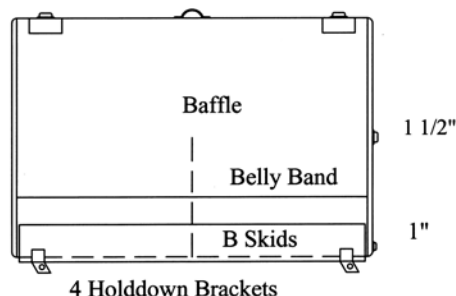

Stock#	Capacity	Gauge	Dimensions
1300	300	12	38" dia x 61"
1325	550	12	48" dia x 72"
1350	1,000	10	48" dia x 11'
1400	2,000	10	64" dia x 12'

Tanks Include:

- * Baffle
- * Belly Band (reinforced skids)
- * Anchor Brackets on Skids
- * Reinforced Top Openings for Pump

These tanks are not intended to be used for interstate commerce. They are not designed to meet Title 49 of the U.S. Federal Register governing transportation.



Pumps and Hose Reels Available



Rectangular Tanks Available



Water Tanks

PORTABLE FUEL TANKS

RECTANGULAR TANKS



*Standard - Red or White Paint
(other colors available)

- * 2" Fill Opening
- * 2" Reinforced Pump Opening
- * 1" Drain

Stock#	1 Compartment Tanks
4500	119 Gallon 49" L x 24" x 24" H 14 gauge
4510	150 Gallon 61" L x 24" x 24" H 14 gauge
4520	190 Gallon 61" L x 30" x 24" H 12 gauge

Stock #	2 Compartment Tanks
4553	119 Gallon 49" L x 24" x 24" H 14 gauge
4554	150 Gallon 61" L x 24" x 24" H 14 gauge
4555	190 Gallon 61" L x 30" x 24" H 12 gauge

L-SHAPED TANKS



*Standard - Red or White Paint
(other colors available)

- * 2" Fill Opening
- * 2" Reinforced Pump Opening
- * 1" Drain

Stock#	1 Compartment Tanks
4530	119 Gallon 61" L x 32" x 25" H 14 gauge

Stock #	2 Compartment Tanks
4556	119 Gallon 61" L x 32" x 25" H 14 gauge

Stock#	Optional Items
4557	Extra for 2 Lift Lugs
4559	Extra for 2 Anchor Brackets

These tanks are designed and manufactured to be used as transfer tanks solely for private use. They do not have the necessary features to be used as auxiliary fuel tanks to your truck's fuel supply system. These tanks are not intended to be used commercially or for interstate commerce.

PACKAGE UNITS

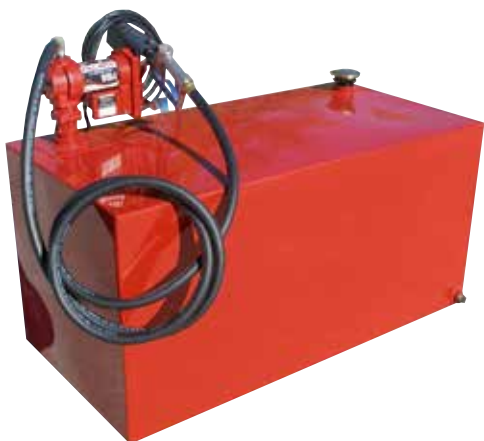

- * Fill-Rite 1210G 12 volt pump w/ 12' Hose and Nozzle
- * 2" Pre-Vent Fill Cap
- * 1" Drain Plug

Stock#	Rectangular Tank Package
4500-P	119 Gallon 49" L x 24" x 24" H 14 gauge
4510-P	150 Gallon 61" L x 24" x 24" H 14 gauge
4520-P	190 Gallon 61" L x 30" x 24" H 12 gauge

Stock #	L-Shaped Tank Package
4530-P	119 Gallon 61" L x 32" x 25" H 14 gauge

UL LABELED RECTANGULAR TANKS

UL Listed • Stationary Use Only

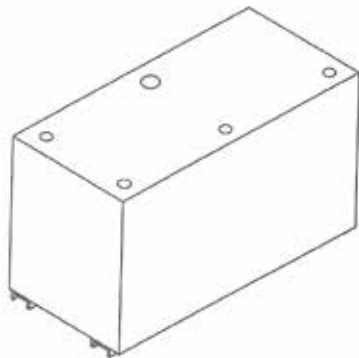

FUEL CUBE

S
I
N
G
L
E
W
A
L
L

Gallons	Length	Width	Height	Weight
120	26"	30"	36"	208#
280	60"	30"	36"	425#
500	60"	32"	60"	890#
1000	120"	32"	60"	1425#
1500	120"	48"	60"	1900#
2000	130"	60"	60"	2500#

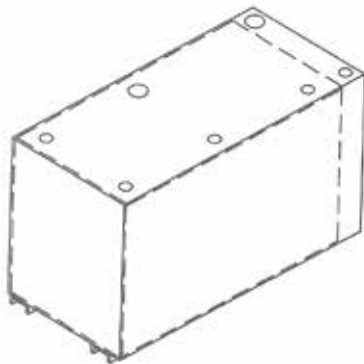

FUEL CUBE II

D
O
U
B
L
E
W
A
L
L

120	32"	30"	36"	600#
280	66"	30"	36"	900#
500	66"	32"	60"	1900#
1000	126"	32"	60"	3000#
1500	126"	48"	60"	4200#
2000	136"	60"	60"	4800#

See Page 13 for portable rectangular tanks

CUSTOM SIZES AVAILABLE!

GENERATOR BASE TANKS



- * Stores diesel fuel for emergency and backup generators
- * Low profile design serves as structural support for generator mounting
- * High load bearing capacity
- * Tested and listed by UL as a Special Purpose Tank
- * Available in single wall, double wall, fire resistant, and fire protected designs



FARM TANKS ON STANDS

Stock #	150 GALLON
2030	14 Ga. - 30" x 49"
	300 GALLON
2040	14 Ga. - 38" x 61"
	520 GALLON
2055	14 Ga. - 50" x 60"
	550 GALLON
2070	12 Ga. - 48" x 72"



ANCHOR STRAPS
90

TANK STANDS

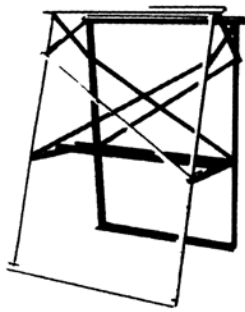

84" LEGS
FOR TANKS
UP TO
300 GALLONS
Stock #6030

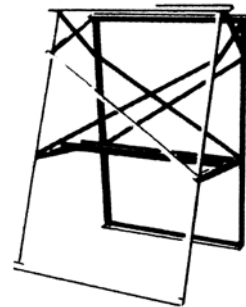

84" LEGS
FOR TANKS
UP TO
550 GALLONS
Stock #6050

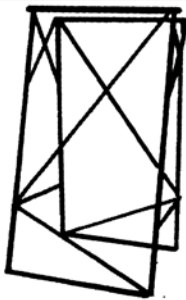

84" LEGS
FOR 150
GALLON TANKS
Stock #6020

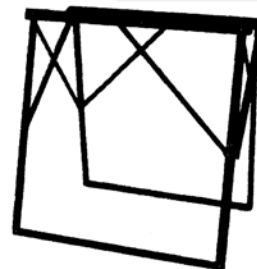

48" LEGS
FOR 150
GALLON TANKS
Stock #6100

PACKAGE UNITS



UNITS WITH STANDS

Stock#	Description
1630	150 Gal. Tank - 84" Stand - 1" Fittings
1210	300 Gal. Tank - 84" Stand - 1" Fittings
1230	520 Gal. Tank - 84" Stand - 1" Fittings
1240	550 Gal. Tank - 84" Stand - 1" Fittings (12 ga.)

1" FITTINGS INCLUDE:

- 2" Hinged Fill Cap
- 1" x 12' Single Braid Hose
- 1" Aluminum Nozzle
- 1" x 1" Ball Valve
- Sidewinder Gauge
- Filter Assembly



ELECTRIC PUMP PACKAGE UNITS

NON-UL FARM TANK PACKAGE UNITS



Stock #	Description
1980	300 Gallon B Package Unit
1982	520 Gallon B Package Unit
1984	550 Gallon B Package Unit
1986	1,000 Gallon 4' x 11' B Package Unit
1987	1,000 Gallon 64" x 6' B Package Unit
1988	2,000 Gallon 64" x 12' B Package Unit
1989	2,500 Gallon 64" x 15' B Package Unit

Package Includes: Fill-Rite 115V Pump with Meter, Suction Stub, Fill Cap, Gauge, and 1" Drain Plug

UL PACKAGE UNITS



Stock #	Description
4219	300 Gallon B UL Package Unit
4229	550 Gallon B UL Package Unit
4249	1,000 Gallon 4' x 11' B UL Package Unit
4259	1,000 Gallon 64" x 6' B UL Package Unit
4279	2,000 Gallon 64" x 12' B UL Package Unit
4289	2,500 Gallon 64" x 15' B UL Package Unit

Package Includes: Fill-Rite 115V Pump with Meter, Suction Stub, Fill Cap, Gauge, Emergency Vent, Morrison #749 Pressure Vacuum Vent with Pipe, and 1" Drain Plug

DECALS AND WARNING LABELS

NO SMOKING **DIESEL**

USED OIL **UNLEADED**

Combustible Motor Oil
 Diesel No Smoking
 Flammable Unleaded
 Kerosene
 Used Oil **Stock #4295**
 Waste Oil *** Red on White**
 *** 3" x 12"**

Stock #4299 **Stock #4298**



Gas



Diesel

10 3/4" sq

This Tank Contains
DYED DIESEL FUEL
NON-TAXABLE USE ONLY
PENALTY FOR TAXABLE USE

This Tank Contains
UNDYED DIESEL FUEL
For On Highway USE ONLY
Legal For Motor Vehicle Use

DIESEL REGULATIONS

Stock #4269
*** Black on White**
*** 6" x 10"**

NFPA Diamond Label
 (includes 4" vinyl numbers)



Stock #4297
*** 10-3/4" sq**

STORAGE TANKS

TANKS DESIGNED FOR STATIONARY USE ONLY

NON-UL FARM SKID TANKS

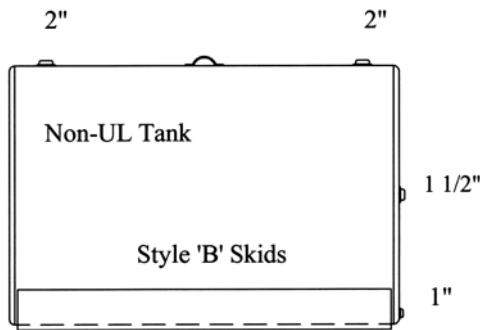

Stock #	Gallons	Gauge	Dimensions
4210	150	14	30" x 4'
4215	300	14	38" x 5'
4220	520	14	50" x 5'
4225	550	12	48" x 6'
4230	750	12	48" x 8'
4240	1000	12	48" x 11'
4250	1000	12	64" x 6'
4260	1500	10	64" x 9'
4270	2000	10	64" x 12'
4280	2500	10	64" x 15'

Openings: 2" Pump, 2" Fill, 1 1/2" Gauge in head, 1" Drain, and Lift Lug(s)

U.L. LABELED SKID TANKS

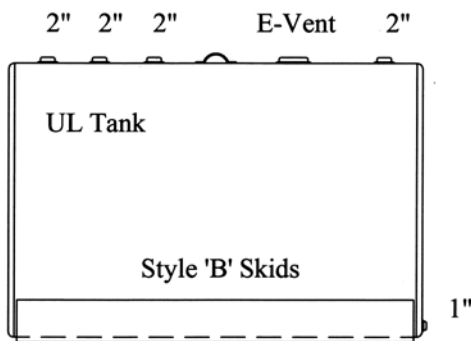

Stock #	Gallons	Gauge	Dimensions
4208	150-UL	12	30" x 4'
4218	300-UL	12	38" x 5'
4228	550-UL	12	48" x 6'
4238	750-UL	10	48" x 8'
4248	1000-UL	10	48" x 11'
4258	1000-UL	10	64" x 6'
4268	1500-UL	7	64" x 9'
4278	2000-UL	7	64" x 12'
4288	2500-UL	7	64" x 15'

Openings: 2" Pump, 2" Fill, 2" Top Gauge, 2" Normal Vent, Emergency Vent*, 1" Drain, and Lift Lug(s)

*Emergency Vent Size

150 - 300 Gallon Tanks.....3"

550 - 750 Gallon Tanks.....4"

1000 - 2500 Gallon Tanks.....6"

EXTRA ITEMS

Stock#	Description	Stock#	Description
35	Extra 1/4" - 2" Opening	72	Extra for Baffle - 520 Gal.
36	Extra for Reinforced Opening	73	Extra for Baffle - 12 Ga.: 560-750-1000 Gal. - 48" dia.
37	Extra for 2-1/2" - 4" Opening	74	Extra for Baffle - 10 Ga.: 750-1000 Gal. - 48" dia.
38	Extra for 6" Opening	75	Extra for Baffle - 12 Ga.: 1000 Gal. - 64" dia.
51	Extra for Lifting Lug	76	Extra for Baffle - 10 Ga.: 1000-1500-2000 Gal. - 64" dia.
70	Extra for Baffle - 150 Gal.	77	Extra for Baffle - 7 Ga.: 1500-2000 Gal. - 64" dia.
71	Extra for Baffle - 300 Gal.		

FUEL PUMPS

FILL-RITE

Fill-Rite® is the global leader in fuel transfer pumps. For over 50 years the world has turned to Fill-Rite for industry leading fuel transfer pumps that deliver superior performance and rugged dependability.

115 VOLT PUMPS



Stock #7621

FR700V - 18 GPM

- * No Meter
- * 115 Volt
- * 3/4" x 12' Hose
- * Manual Nozzle



Stock #7631

FR701V - 15 GPM

- * With Meter
- * 115 Volt
- * 3/4" x 12' Hose
- * Manual Nozzle

115/230 VOLT HIGH FLOW PUMPS



Stock #7634

FR310VB - 30 GPM

- * No Meter
- * 115/230 Volt
- * 1" x 18' Hose
- * Automatic Nozzle



Stock #7636

FR311VB - 27 GPM

- * With Meter
- * 115/230 Volt
- * 1" x 18' Hose
- * Automatic Nozzle

PUMP WITH REMOTE DISPENSER

Convenient for larger diameter tanks



Stock #7637

FR313V - 27 GPM

- * Remote Pump
- * 115/230 Volt
- * Anti-Siphon Kit
- * 1" Discharge
- * Used w/Remote Dispenser



Stock #7638

FR902CRU

- * Cabinet Meter
- * 115/230 Volt
- * 1" Discharge
- * 4 Digit Gallon Meter

SUCTION PIPES FOR PUMPS

Stock #	Description
8856	1-1/4" X 38"
8857	1-1/4" X 48"
8858	1-1/4" X 64"

Stock #	Description
8845	1" X 36"
8850	1" X 46"
8855	1" X 61"

FUEL PUMPS

12 VOLT DC PUMPS



FR1210G - 15 GPM

- * No Meter
- * 12 Volt DC
- * 3/4" x 12' Hose
- * Manual Nozzle
- * Telescoping Pipe (20" to 34.5")

Stock #5153



FR1211G - 15 GPM

- * With Meter
- * 12 Volt DC
- * 3/4" x 12' Hose
- * Manual Nozzle
- * Telescoping Pipe (20" to 34.5")

Stock #5154

12 VOLT DC HIGH FLOW PUMPS



FR4210G - 20 GPM

- * No Meter
- * 12 Volt DC
- * 1" x 12' Hose
- * Manual Nozzle
- * Telescoping Pipe (20" to 34.5")

Stock #5155



FR4211G - 20 GPM

- * With Meter
- * 12 Volt DC
- * 1" x 12' Hose
- * Manual Nozzle
- * Telescoping Pipe (20" to 34.5")

Stock #5156

FR152 Piston Hand Pump

- * 20 Gal. per 100 strokes
- * with 3/4" x 8' Hose
- * with telescoping steel pipe



Stock# 5160

FR112 Rotary Hand Pump

- * 10 Gal. per 100 revolutions
- * with 3/4" x 8' Hose
- * with telescoping steel pipe



Stock# 5170

Model DS Drum Pump

- * 1 pint per stroke
- * garden hose threads on end
- * with telescoping steel pipe



Stock# 7650

807C Meter

- * 5 to 20 GPM
- * 3/4" Inlet / Outlet



Stock# 5175

901C Meter

- * 6 to 40 GPM
- * 1" Inlet / Outlet



Stock# 5180

GPI Electronic Digital Meter

- * 3 to 30 GPM
- * 1" Inlet / Outlet (3/4" reducer included)



Stock# 5190



TANK LEVEL GAUGES

TOP MOUNT GAUGE

Scully Econ -O - Gage

1/4 - 1/2 - 3/4 Increments



Stock#	Description
7122	24"
7129	30"
7137	37"
7148	48"
7164	64"
7140	42" - 44" Oval Tank Gauge
7165	Vial for Top Mount Gauge

END MOUNT GAUGE

Rochester Gauge

1/4 - 1/2 - 3/4 Increments



Stock#	Description
7100	38"
7120	48"
7130	64"
7150	Adjustable Sidewinder Gauge
7000	Dial Glass - Standard Gauge
7001	Dial Glass - Sidewinder Gauge
7136	Gasket for Gauges

GAUGE STICKS



Stock#	Description
7806	55 Gallon Drum Stick
7808	8' Calibrated to 6'
7810	10' Calibrated to 8' **
7812	12' Calibrated to 10' **
7814	14' Calibrated to 12' **
7816	16' Calibrated to 14' **
7818	12 1/2' to 10 1/2' - Folding
7820	15 1/2' to 14' - Folding
7826	Water Finding Paste

** Available in 1 piece or snap together design

GOLDEN GAUGE

Scully Golden Gauge

Reads in Inches

Adjustable



Stock#	Description
7838	38"
7848	48"
7860	60"
7864	64"
7872	72"
7898	108"
7902	275 Oval (reads in gallons)

CLOCK GAUGE

For use in vertical or horizontal tanks up to 12 feet



Stock#	Description
7900	818 Clock Gauge
7901	918 Clock Gauge with High Level Alarm

OPW 200TG GAUGE

For use in vertical or horizontal tanks up to 18 feet



Stock#	Description
7907	200TG GAUGE

SUPREME TANK GAUGE

For use in vertical tanks up to 50 feet



Stock#	Description
7908	4" Metal Float
7909	4" Stainless Float

OVERFILL PREVENTION/SPILL CONTAINMENT

SPILL CONTAINER

Contains small spills and drips from fill nozzle. Lockable with drain valve. White powder coated.



Stock#

7930 - 3 1/2 Gallon
7932 - 5 Gallon
7935 - 7 1/2 Gallon

CLOCK GAUGE ALARM

918 Clock Gauge with a built-in high level warning alarm. Contains a battery powered alarm unit that is mounted remote from gauge.



Stock#

7901

HIGH LEVEL, LOW LEVEL, OR INTERSTITIAL ALARM



Alarm and float level sensor can be set to provide an audible alarm for a high level, low level, or serve as an interstitial alarm.

Stock#

7951 - LS600 Level Switch
Standard Lengths
7952 - LS600 Level Switch
Non-Standard Lengths
7953 - LS600 LDBN Leak Switch
Interstitial Leak Switch
7950 - LC 1002
Alarm Console



KRUEGER LEAK GAUGE

For double wall tanks

Stock#	Size
7945	38"
7946	48"
7947	64"
7949	96"



REMOTE SPILL CONTAINER

Contains fuel spillage during remote tank filling operations. 15 gallon capacity. Lockable lid and white powder coated. 1" drain with locking ball valve included. Shown with pedestal - available without for direct mounting on tank.

With Pedestal (shown)

Stock#	Size
7938	2"
7939	3"



Without Pedestal - Direct Mount

Stock#	Size
7940	2"
7941	3"

OVERFILL PREVENTION VALVE

Used in a tight fill application, the valve terminates flow of product when the liquid level reaches a preset warning level (90 - 95%).

Stock#	Size
7925	2"
7926	3"



COMBINATION VENT / OVERFILL ALARM

Pressure / vacuum vent equipped with high intensity, audible alarm alerts you when tank is near full. Fully mechanical -- no batteries needed.

Stock#
7920 - 2"
7921 - 3"



FARM TANK HOSE

ONE BRAID • TOP QUALITY WITH STATIC FREE WIRE

Stock#	Description
7012	3/4" x 12' Farm Hose
7014	3/4" x 14' Farm Hose
7040	1" x 12' Farm Hose
7045	1" x 14' Farm Hose
7048	1" x 20' Farm Hose



Coupled male and male



BALL VALVES

Stock#	Description
7335	3/4" x 3/4" (Male x Female)
7330	1" x 1" (Male x Male)
7340	1" x 1" (Male x Female)

BALL VALVES FULL PORT



Stock#	Description
7924	1-1/2"
7928	2" Locking Ball Valve

SWIVELS

• U.L. Listed • Multiplane



Stock#	Description
7290	3/4" M x 3/4" F
7295	1" M x 1" F
4860	1" High Flow for High Volume Pumps

BREAK AWAYS



Stock#	Description
7280	3/4" Standard
7285	3/4" Reconnectable
7286	3/4" Hose
7288	1" Reconnectable
7289	1" Hose

SERVICE STATION PUMP HOSE

Stock#	Description
7052	3/4" x 14' Service Station Hose
7054	3/4" x 16' Service Station Hose
7057	1" x 20' Service Station Hose

FARM TANK NOZZLES

Power Pump Use • Gravity Flow Use • Listed by UL



Stock#	Description
7250	3/4", 1" Aluminum
7255	3/4", 1" Aluminum Unleaded

NEW AUTOMATIC NOZZLES

Husky 1GS
• Use with Farm Pumps
• With Flo-Stop



Stock#	Description
7272	3/4", 1" Leaded
7273	3/4", 1" Unleaded
7274	3/4", 1" IGS Hi-Flow

NEW AUTOMATIC NOZZLES

HUSKY X 1+10S
• Service Station Use
• With Flo-Stop



Stock#	Description
7270	3/4" Leaded
7271	3/4" Unleaded
7275	3/4", 1" 1+HS Hi-Flow



FILL CAPS LOCKING HINGE TYPES

Stock#	Description
7400	2" Male Threads - 235
7440	4" Female Threads - 232

WATER TIGHT FILL CAPS



Stock#	Description
7444	4" Water Tight Fill Cap
8804	4" x CL Nipple

PRESSURE VACUUM FILL CAPS



Stock#	Description
7570	2" Pre-Vent I Complete
7575	Cap Only for Pre-Vent I
7576	Adapter Only for Pre-Vent I
7577	2" Pre-Vent II Complete

COMBINATION FILL CAPS AND VENT

- Screened Vent
- Weather Hood
- Locking Hinge Type



Stock#	Description
7580	2" Male Threads

EMERGENCY VENT



Stock#	Description
7765	3" Vent 8 oz. Pressure Male
7770	4" Vent 8 oz. Pressure Female
7771	4" Vent 8 oz. Pressure Male
7775	6" Vent 8 oz. Pressure Female
7776	6" Vent 8 oz. Pressure Male
7778	8" Vent 8 oz. Pressure Male
7779	8" Vent 8 oz. Pressure Female
7780	8" Vent 8 oz. Flanged w/bolts & gasket
7781	10" Vent 8 oz. Flanged w/bolts & gasket

UPFLOW VENT



Stock#	Description
8480	2" Upflow Vent
8485	3" Upflow Vent

T-VENT



Stock#	Description
8460	1-1/2" T-Vent
8470	2" T-Vent
8475	3" T-Vent

• See Page 24 for Vent Extension Pipes

PRESSURE-VACUUM VENT



Stock#	Description
7581	2" 749 (Up to 2500 Gallons)
7582	2" 748A Pressure Vacuum Vent
7583	3" 748A Pressure Vacuum Vent

GOLDEN ROD BRAND



Stock#	Description
7750	Filter w/Element
7751	Replacement Element
7752	Container Bowl

FUEL GUARD FILTER



Stock#	Description
7755	Element (1") 10 Micron
7756	Element (3/4") 10 Micron
7757	Head Only (1")
7758	Coop Style Head
7759	Head Only (3/4")
7761	Element (1") 30 Micron
7762	Element (3/4") 30 Micron
7768	Element (1") 30 Micron for High Flow 800-30
7769	Head Only (1") for High Flow 805

BIO-TEK FILTERS

Stock#	Description
7766	3/4" Ethanol Filter up to E15

DUO SAFETY LADDER

Stock #8000

12'



PIPE AND FITTINGS

Stock# Description

8940	3/4" Street Elbow
8941	1" Street Elbow



Street Elbow

8689	1" x 3/4" Bushing
8710	6" Pipe Plug
8711	4" Pipe Plug
8713	3" Pipe Plug
8715	2" Pipe Plug
8716	1-1/2" Pipe Plug
8718	1" Pipe Plug
8719	3/4" Pipe Plug



Pipe Plug

8740	1/2" Flange
8741	3/4" Flange
8760	1" Flange
8761	1-1/2" Flange
8770	2" Flange
8780	3" Flange
8790	4" Flange
8792	6" Flange



Tank Flange

8798	3/4" x CL Nipple
8817	3/4" x 3" Nipple
8819	3/4" x 8" Nipple
8797	1" x CL Nipple
8799	2" x CL Nipple
8800	2" x 3" Nipple
8803	2" x 6" Nipple Galvanized
8806	2" x 12" Nipple Galvanized
8805	3" x 12" Nipple Galvanized
8804	4" x CL Nipple
8807	4" x 6" Nipple



Nipple

8809	3/4" Coupling
8810	1" Coupling
8811	1-1/2" Coupling
8812	2" Coupling



Coupling

QUICK CONNECT FITTINGS

Stock# Description

8210	2" Aluminum Female A
8211	3" Aluminum Female A
8212	4" Aluminum Female A



8213	2" Aluminum Male F
8214	3" Aluminum Male F
8215	4" Aluminum Male F



8216	2" Aluminum Cap DC
8217	3" Aluminum Cap DC
8218	4" Aluminum Cap DC



DOUBLE TAPPED TANK BUSHINGS

Stock# Description

8530	4" X 2" X 2"
8540	4" X 1-1/2" x 1-1/2"
8600	3" x 2" x 2"
8610	3" x 1-1/2" x 1-1/2"
8630	2" x 1-1/2" x 1-1/2"
8650	2" x 1" x 1"
8660	2" x 1/2" x 1/2"



EXTENSION PIPES FOR NORMAL VENT

Stock# Description

8815	2" x 4 FT Pipe Galvanized
8820	2" x 5 FT Pipe Galvanized
8825	2" x 6 FT Pipe Galvanized
8830	2" x 7 FT Pipe Galvanized
8835	2" x 8 FT Pipe Galvanized
8840	2" x 9 FT Pipe Galvanized

SUCTION PIPES FOR PUMPS

Stock# Description

8845	1" x 36"
8850	1" x 46"
8855	1" x 61"
8856	1-1/4" x 38"
8857	1-1/4" x 48"
8858	1-1/4" x 64"

ABOUT US

We-Mac was founded in 1962 in Atchison, KS. Our market niche initially was small tanks (under 2,000 gallons) to the rural Midwest. 1966 found We-Mac beginning production of large shop fabricated tanks and later adopting the STI-P3 underground tank technology in 1983. Today we offer a full line of tanks from 50 gallons to 50,000 gallons to serve nearly all industries, both domestic and international.

We are a proud Member of the Steel Tank Institute and licensed to build many of the latest technologies offered through the Institute including: Fireguard® fire-rated tanks, Flameshield® Tanks, and GenTank® Generator Base Tanks. In addition, we also offer a full line of UL listed tanks, farm tanks, stainless steel industrial tanks, rectangular lube tanks, and portable tanks for all industries.

Our founding partners, Gene McCarty and Gene Harris, established a rock solid foundation for the Company to build upon. The Harris family continues their consistent leadership today, committed to upholding the legacy of our founders.



We-Mac Mfg. announces its updated website –

www.wemactanks.com

New Information Available Online

- Ready to print tank charts
- Tank chart calculator
- Brochures
- Installation instructions
- Tank weights
- Tank emergency vent sizes

Online Store – *SHOP NOW!* – Tanks, Gauges, Filters, and more



WEMACTANKS.COM



PRSR STD
U.S. Postage
PAID
Kansas City, MO
Permit #2623

WE-MAC MANUFACTURING CO.

Quality Steel Storage Tanks Since 1962



For over 50 years customers have relied on We-Mac to provide industry leading steel storage tanks, competitive prices, and on time deliveries!



Atchison, KS 66002
11016 U.S. Hwy 59

