



RECEIVING, INSPECTING AND UNLOADING YOUR TANK

- ✓ Do not drop or roll a tank off a truck onto the ground. Please see information below for proper unloading instructions.
- ✓ Upon arrival at the destination, the purchaser and/or his agent shall be responsible for inspection for damage in transit. If tanks are shrink wrapped for shipment they must be unwrapped and inspected for damage prior to signed the bill of lading. If damage has occurred or parts are missing, the purchaser should document this on the bill of lading, file a claim with the carrier, and notify the manufacturer prior to putting the tank into service.
- ✓ Verify that the tank part number on the packing slip matches the tank bar code being delivered.
- ✓ Please match tank components to bill of lading. Some tank components may be shipped inside the tank. Remove any components shipped inside the tank before putting the tank into a vertical position. Loose items that are installed inside the tank can be fitted up before the tank is put into a vertical position.

TANK UNLOADING

HORIZONTAL TANKS

- ✓ Tanks shall be shrink-wrapped if ordered. Snyder Industries strongly recommends protective wrap packaging to reduce the chance of damage to the tank during transportation. Snyder is not responsible for damage caused during freight that is a result of failure to order protective shrink wrap packaging.
- ✓ Tanks should be hand carried, moved with a handling cart, or moved with a forklift with protected or rounded fork extensions (to prevent sharp forks from damaging tanks and to provide adequate support for the tank as it is being moved).
- ✓ Tanks should be loaded and unloaded from a horizontal position in the truck with a minimal amount of sliding. The tank shall be hand carried, moved with a handling cart, or moved with a forklift with protected or rounded fork extensions to minimize sliding.
- ✓ Tanks should be loaded or unloaded from a dock of proper height or with a forklift with protected or rounded fork extensions. **NEVER drop or roll a tank off of a truck onto the ground since this may damage the tank and void the warranty.**

SMALL VERTICAL and CONE BOTTOM TANKS (< 2000 GALLON CAPACITY)

- ✓ Tanks shall be shrink-wrapped if ordered. Snyder Industries strongly recommends protective wrap packaging to reduce the chance of damage to the tank during transportation. Snyder is not responsible for damage caused during freight that is a result of failure to order protective shrink wrap packaging.
- ✓ Tanks should be hand carried, moved with a handling cart, or moved with a forklift with protected or rounded fork extensions (to prevent sharp forks from damaging tanks and to provide adequate support for the tank as it is being moved).
- ✓ Tanks should be loaded and unloaded from a horizontal or vertical position in the truck with a minimal amount of sliding. The tank shall be hand carried, moved with a handling cart, or moved with a forklift with protected or rounded fork extensions to minimize sliding.
- ✓ Tanks should be loaded or unloaded from a dock of proper height or with a forklift with protected or rounded fork extensions. **NEVER drop or roll a tank off of a truck onto the ground since this may damage the tank and void the warranty.**

LARGE VERTICAL & CONE BOTTOM TANKS (≥ 2000 GALLON CAPACITY)

- ✓ Tanks shall be shrink-wrapped if ordered. Snyder Industries strongly recommends protective wrap packaging to reduce the chance of damage to the tank during transportation. Snyder is not responsible for damage caused during freight that is a result of failure to order protective shrink wrap packaging.
- ✓ Tanks should be moved, loaded, and unloaded in a horizontal position with a forklift with protected or rounded fork extensions, or with a crane with a spreader bar and 2 slings of appropriate size positioned on each tank as shown below. **NEVER drop or roll a tank off of a truck onto the ground since this may damage the tank and void the tank warranty.**

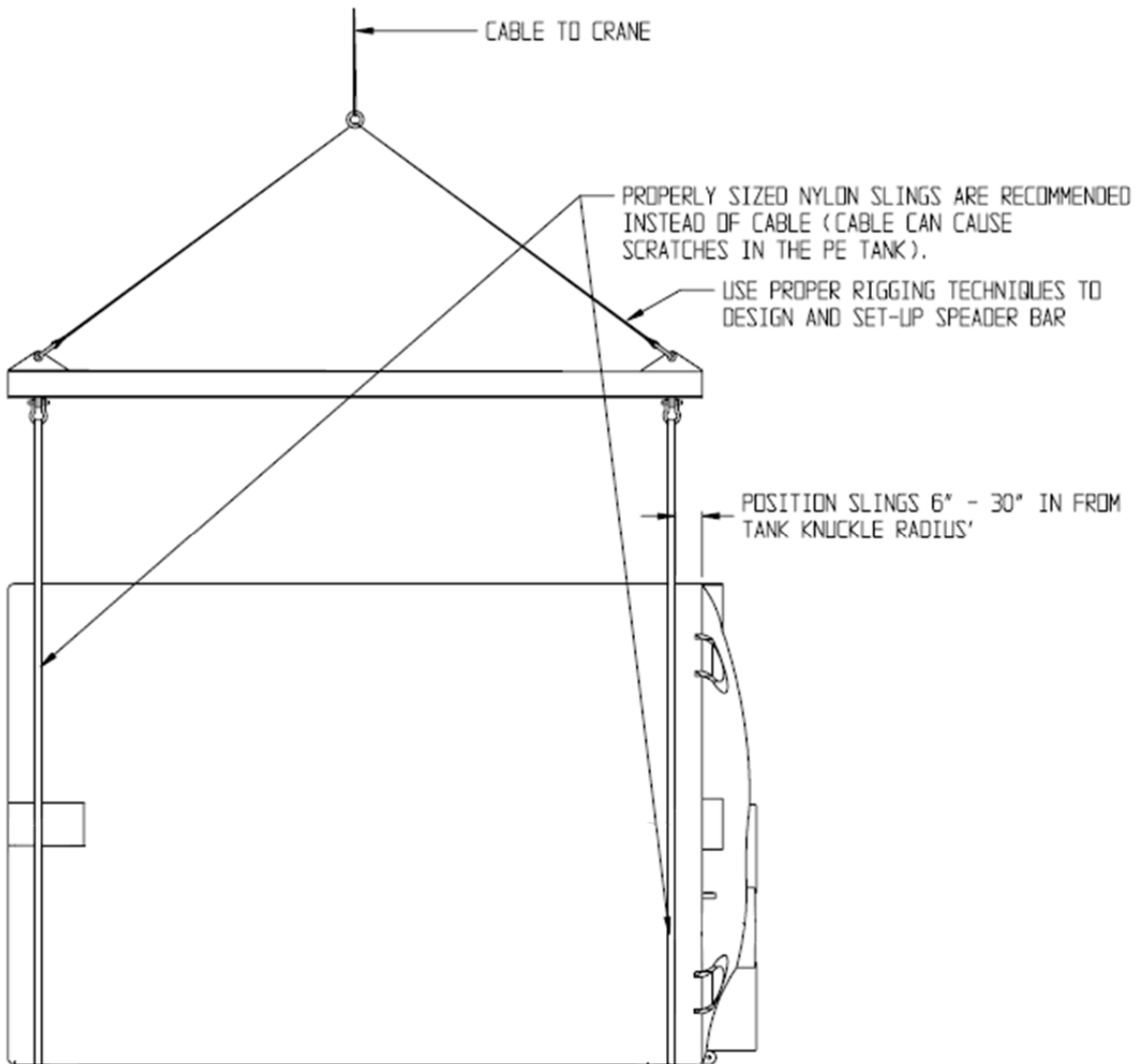

- ✓ Tank lifting lugs are intended for moving the tank from a horizontal position to a vertical position from a firm surface. **Lifting lugs should not be used to load or unload tanks from trailers. This is a dangerous situation since the tank could roll off of the shifting trailer surface as the load is being moved.**

- ✓ After the tank has been placed on a firm, level surface in a horizontal position, the lifting lugs may be used to erect the tank in a vertical position on an appropriate support pad. The tank should be lifted using a symmetrical arrangement of lugs to disperse the load evenly throughout the tank. To properly attach to the lifting lugs a straight clevis should be used with a minimum open throat distance of 1-1/2" and 1" diameter pins. A minimum of 4 lugs should be attached with equal length cables on all large vertical tank sizes except 142" diameter tanks. 142" diameter tanks require 3 lugs to be attached. All tanks should be positioned with 2 lugs closest to the ground prior to lifting the tank to the vertical position. Refer to the figure below for additional information. If the tank does not have lifting lugs, it may be necessary to rig the tank with slings or use a pipe and chain through the tank manway to upright the tank. Please contact the factory for additional information as necessary.

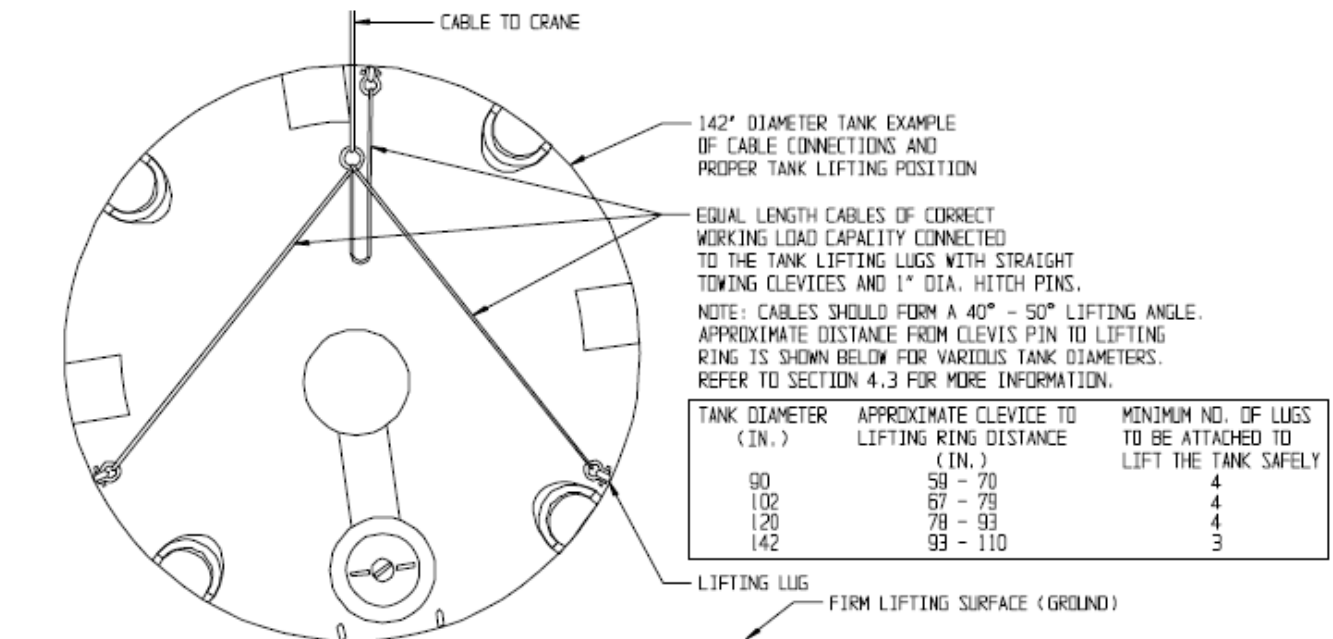

INSULATED TANKS (ADDITIONAL INSTRUCTIONS)

- ✓ Insulated tanks must be moved with devices that have large padded contact surfaces to prevent damage to the foam insulation. **NEVER allow the tank to drop or roll on rough surfaces as this may damage the foam insulation.** When transporting or moving foam insulated tanks, use minimum 4" wide nylon straps and slings to secure the tank. This will assist in decreasing the stress damage on the foam caused by the narrow straps.

CAPTOR CONTAINMENT TANKS (ADDITIONAL INSTRUCTIONS)

- ✓ Captor containment tanks are shipped assembled (primary tank inside of containment tank) with a shipping cable assembly holding the two tanks together. Lift and position the tank as per previous instructions. Once the tank is in position, remove the shipping cables from the tank. Do not leave the shipping cables under the tank. Should a Captor containment tank need to be moved again, the tank would need to be completely drained and the shipping cables would need to be re-attached prior to movement.