

N.B. STAMPARE IN SCALA 1:1 E
VERIFICARE LE QUOTE RIPORTATE, CON UNO
STRUMENTO DI MISURA ADEGUATO



N.B. PRINT THIS SCALE 1:1 AND
VERIFY THE SIGNED QUOTES WITH AN
ADEQUATE MEASURING INSTRUMENT

ATK BINDINGS

R10.xxx

R12LB.xxx
R12G.xxx
R12W.xxx

FR14Y.xxx

C-R12.xxx

FN12.xxx

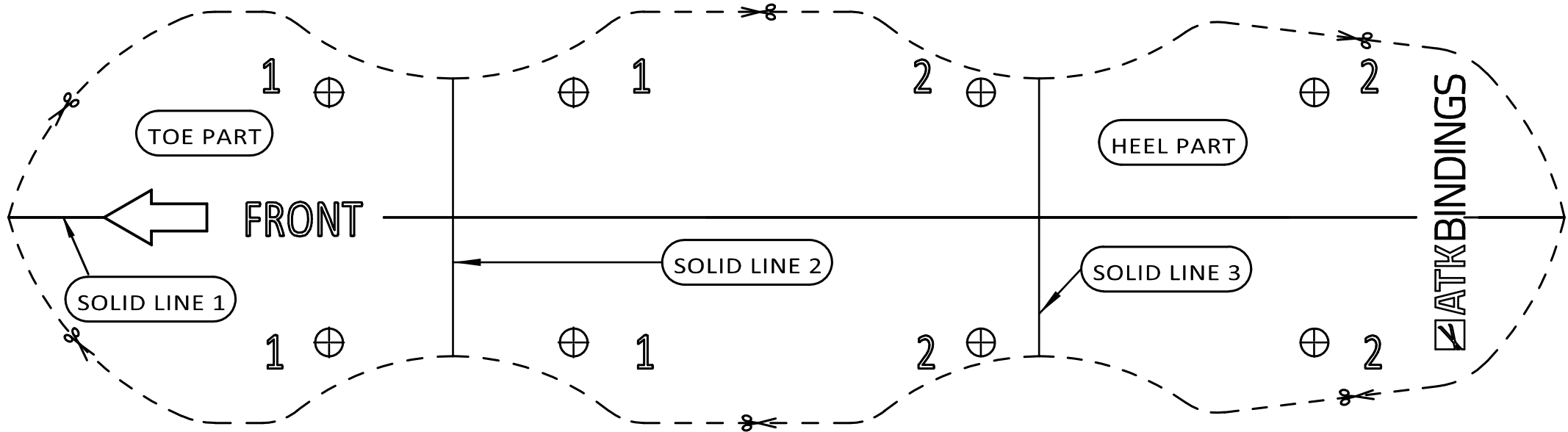

CHECK DIMENSION

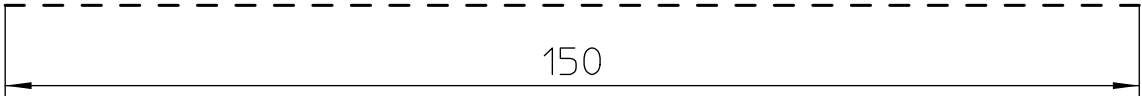

(ENG) HOW TO INSTALL AN ATK® BINDING WITH A DRILLING PAPER TEMPLATE

WARNING ! DANGER!

For the installation of ATK® products is always recommended to consult a specialized dealer having the experience and all the necessary equipment to make a skillfully installation; in case of DIY mounting, or made by untrained staff, the company is automatically relieved of any liability for errors that occurred during the installation of the product. This guide does not replace the experience of specialists in fabrication and installation of these materials.

All images in this manual are purely illustrative.

Before reading this "Installation Guide", it is recommended to read and fully understand the whole content and information provided by "User's Guide" included in the product box.

WHICH ARE THE NEEDED PARTS FOR THE INSTALLATION OF A BINDING

2 toe parts, 2 heel parts (with integrated, additional or without adjustment plate), 1 self-tapping screws kit as indicated on the "user's manual, 1 4mm thick gauge

WHICH TOOLS/GEAR ARE NECESSARY TO PERFORM THE INSTALLATION?

1 or more copies of the printed template at scale 1:1 referred to the product you are going to install 1 electric-driller with a ski drill bit with a diameter indicated by the manufacturer of the skis itself, 1 Pozidriv® 3 screwdriver , adhesive/sealant on the ski manufacturer specifications.

WARNING! DANGER!

IT IS OF THE UTMOST IMPORTANCE FOLLOWING OPERATIONS PERFORM PERFECTLY TO AVOID OR REDUCE THE RISK OF INJURY OR SERIOUS DAMAGE TO THE USER, OR THIRD PARTIES MATERIALS

1) OPERATIONS AND PRELIMINARY CHECKS

- Ensure that the ski is new and in perfect condition.
- Read the instructions and technical specifications provided by the ski manufacturer.
- Check that the thickness of the skis is compatible with the length of the screws.
- Check that the width of the ski is compatible with the size of the binding
- Check that the selected drill bit can drill a hole depth equal or greater than the insertion of the screws.
- For the installation, you must use the boot that will be used in combination with the binding.

2) PREPARATION OF THE SKI

- 1) Trace on the ski the "**LONGITUDINAL CENTRELINE**" that will ensure a proper toe-heel alignment (**PICTURE 1**)
- 2) If the "**PINS AXIS TRANSVERSE LINE**" is already shown on the ski, you can proceed with the indications written in point 3, otherwise you must implement it as indicated in the methods A or B.

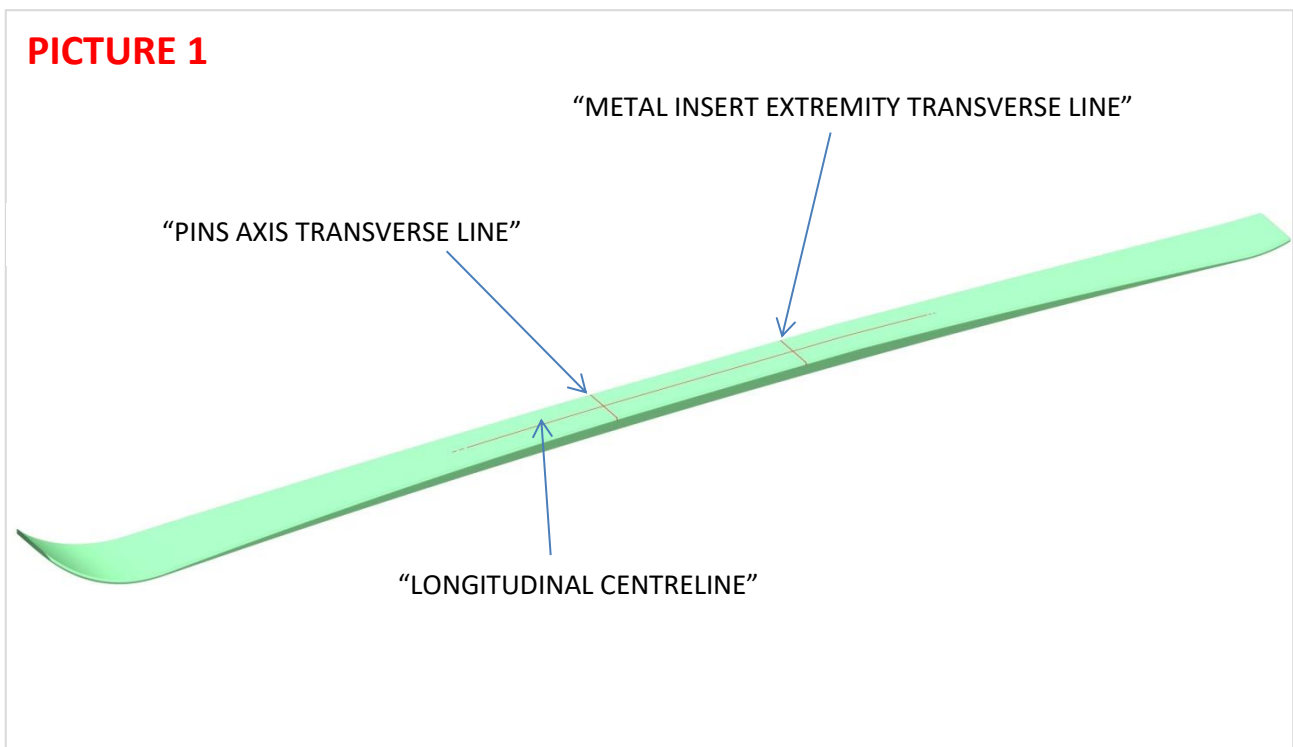

- A) **BOOT CENTER METHOD**: locate the boot center mark indicated on the skis; place the boot on the ski with its tip facing the tip of the ski; match the boot center indicator marked on the sole with the boot center mark indicated on the ski; keeping the boot in the desired position and aligned with the longitudinal centerline of the ski, mark the "**PINS AXIS TRANSVERSE LINE**" matching to the front metal insert on the boot .

- B) **BOOT TIP METHOD:** locate the boot tip mark indicated on the skis; place the boot on the ski, with its tip facing the tip of the ski aligned with the longitudinal axis of the ski; match the boot tip with the boot tip mark indicated on the ski; keeping the boot in the desired position and aligned with the longitudinal axis of the ski, mark the " **PINS AXIS TRANSVERSE LINE** " corresponding to the front metal insert on the boot .
- 3) Place the paper drilling template on the ski with the "FRONT" arrow pointing towards the ski tip, matching perfectly (**PICTURE 2**):
- The "SOLID LINE 1" with the " **LONGITUDINAL CENTERLINE**"
 - The "SOLID LINE 2" with the " **PINS AXIS TRANSVERSE LINE**"

PICTURE 2

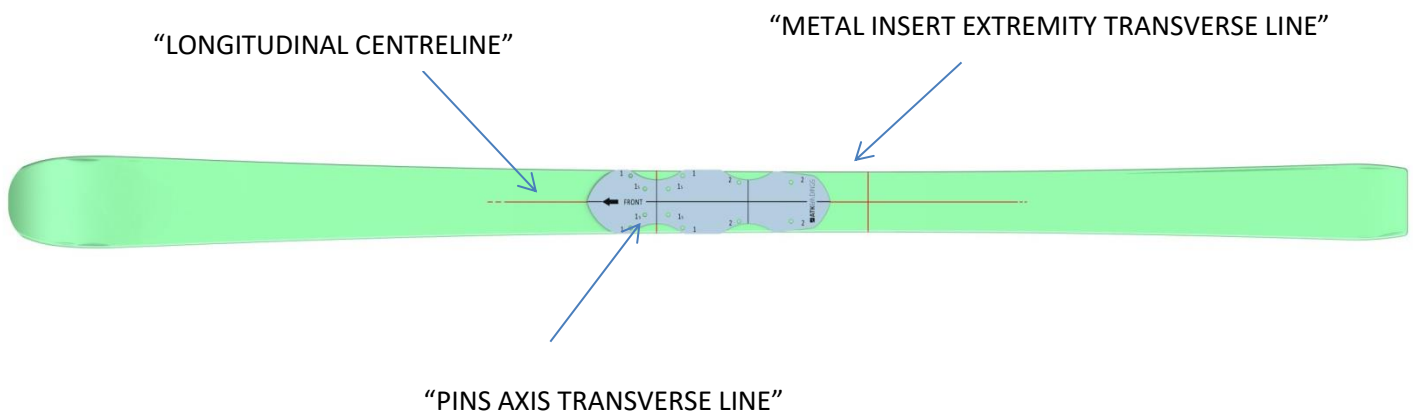

- 4) Fix the drilling template on the ski with the adhesive tape in the obtained position.
- 5) Punch the ski in the center of the 4 holes marked on the template with the number "1"
- 6) Remove the paper template from the skis, place the toe part on the ski to verify the correct positioning of the centers of the holes with the created marks.
- 7) Remove the toe part from the skis and pierce 4 marked points .
- 8) Remove the drilling debris from the newly formed holes and fill the screws seats with the glue / sealant indicated by the ski manufacturer.

- 9) Install the toe part on the ski with the fitting screws, using the manual PZ3 screwdriver without completely tightening the screws, making sure that it is sufficiently stabilized and aligned with the "LONGITUDINAL CENTERLINE" of the ski. (PICTURE 3)

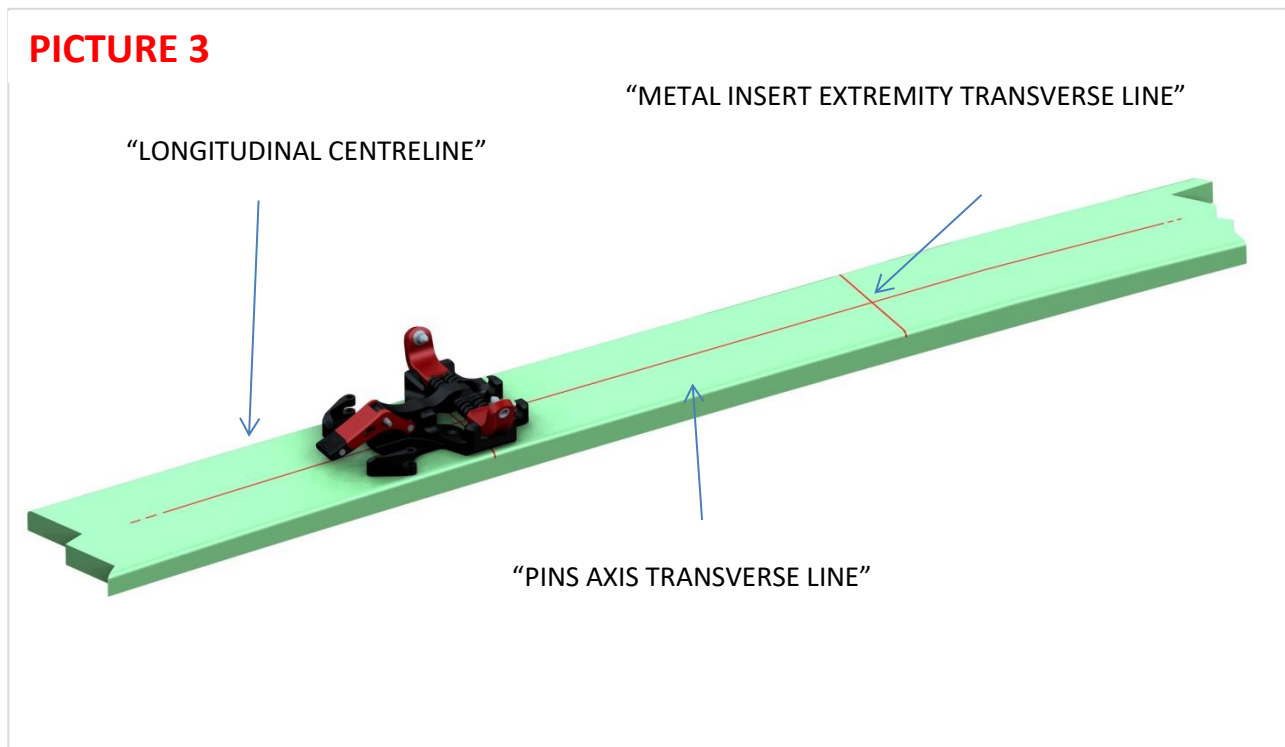

- 10) Hook the boot to the toe part , place the sole on the skis and draw the rear "METAL INSERT EXTREMITY TRANSVERSE LINE" of the boot (PICTURE 4).

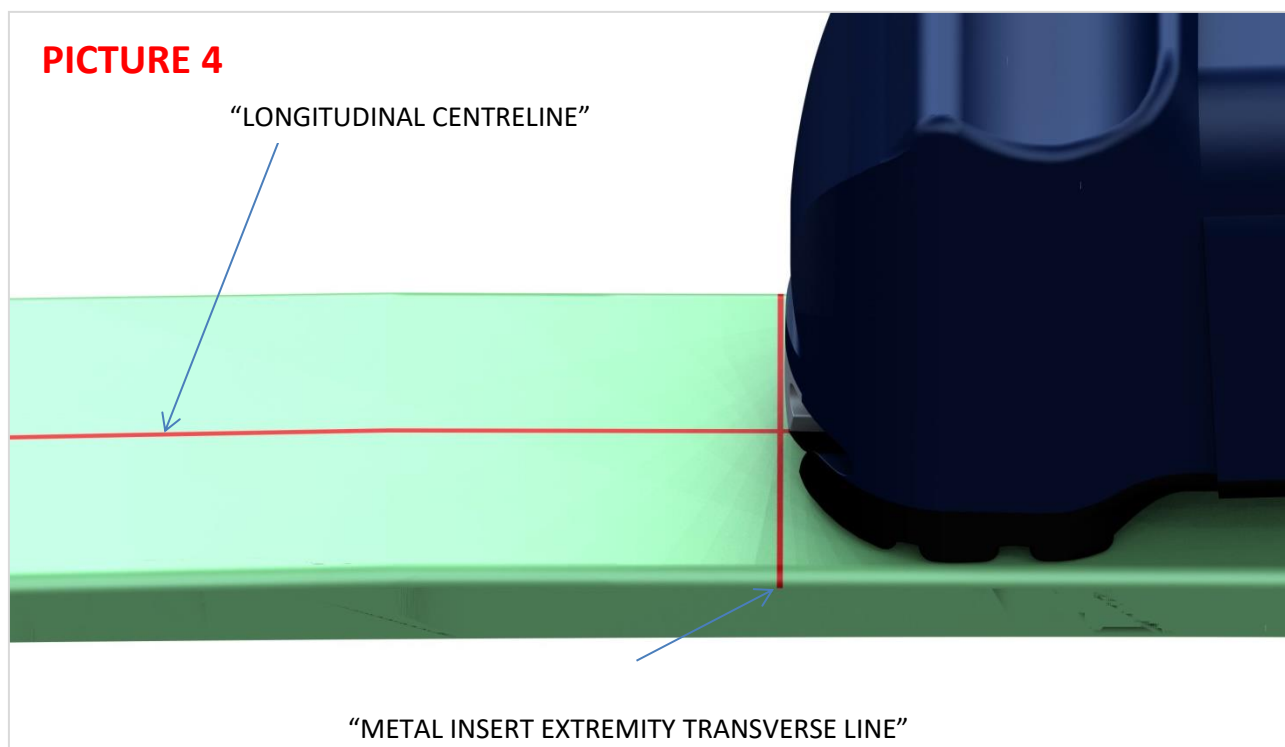

- 11) Remove the boot and place the paper drilling template on the ski matching the “**SOLID LINE 1**” with the “**LONGITUDINAL CENTRELINE**” and the “**SOLID LINE 3**” with the “**METAL INSERT EXTREMITY TRANSVERSE LINE**”, being careful to position the paper template with the “**FRONT**” arrow towards the tip of the ski. (**PICTURE 5**)

PICTURE 5

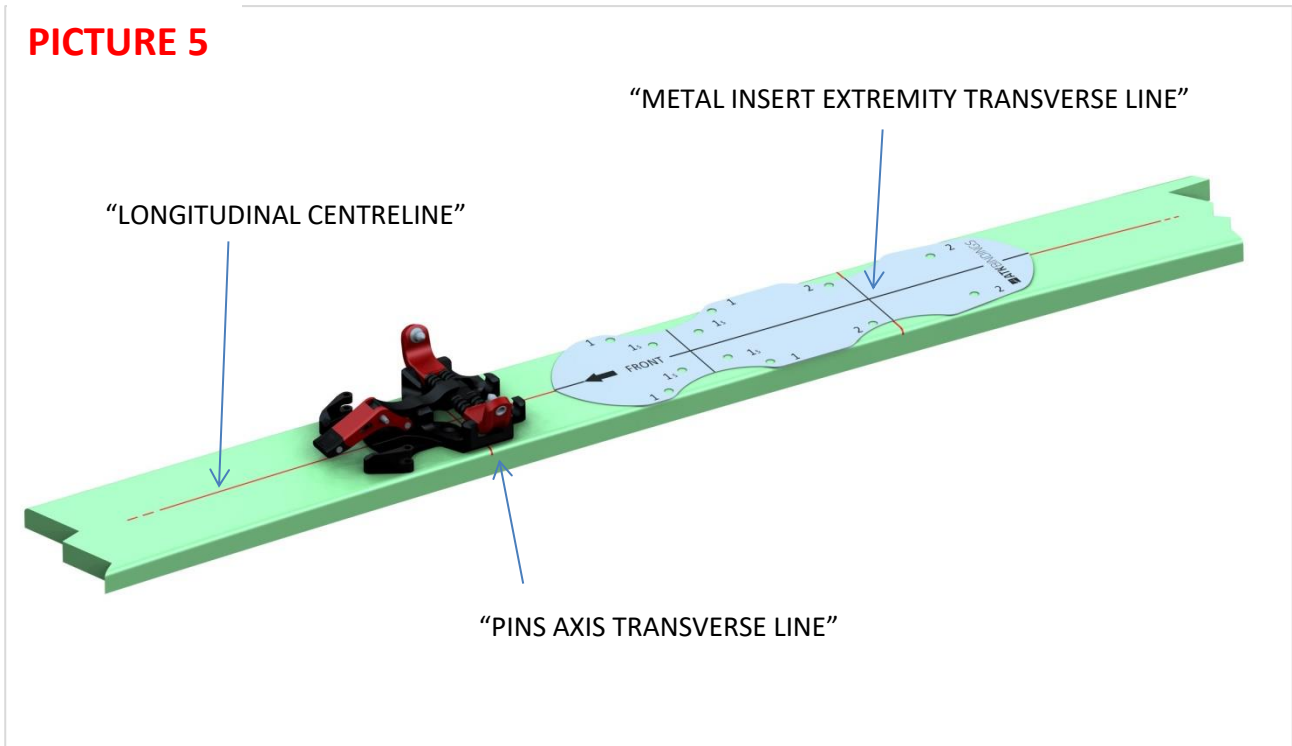

- 12) Fix the paper template on the ski in the obtained position with the adhesive tape
- 13) Punch the ski in the center of the holes marked on the template with number “**2**”
- 14) Place the heel part in the mid of the adjustment plate for those bindings that provide the possibility of adjustment.
- 15) Remove the template, place the heel on the ski to verify the match between the holes of the heel parts and the marks just made on the skis.
- 16) Maintaining the heel part in the identified position , hook the shoe to the tip, place the boot insert on the heel lanyard plugs by checking that the distance between the metal insert and the vertical heel height between the two latching pins about 4 mm (use the supplied gauge).
If this is not the case, repeat the outlined above procedures and check any possible mistake.
- 17) Remove the heel and drill on the 4 punched holes
- 18) Remove the drilling debris from the newly formed holes and fill the screws seats with the glue / sealant indicated by the ski manufacturer.
- 19) Install the heel part on the ski with the 4 fitted screws and the PZ3 screwdriver, tightening with a sufficient torque suitable for the skis structure.
- 20) Completely insert the boot in the toe part first, than into the heel part in order to verify the correct alignment toe – heel: If the installation has been done correctly, the rear metal insert “will fall”

perfectly between the two pins of the heel; if you register a slight misalignment, force the boot toe and heel to align in the correct direction.

- 21) Once you have the perfect alignment, tighten the two front screws of the toe part with a sufficient and appropriate torque to the structure of the ski, pull the boot off the toe part and tighten the two rear screws of the toe part with sufficient and appropriate torque to the structure of the ski.
- 22) Recheck the alignment boot-binding and record , if necessary, the distance boot- binding with the supplied 4 mm thickness gauge. (PICTURE 6)
- 23) In the event that the product provides adjustable release systems (vertical, lateral or both), adjust properly the systems following the instruction given in the “Use and Maintenance guidebook”**

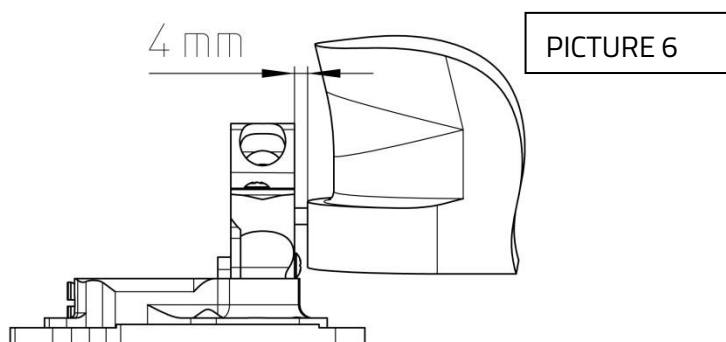

⚠ WARNING ! DANGER !

Before using the newly installed set, make sure that you have successfully completed all of the above steps; In case of indecision, check the equipment at a specialized center!