

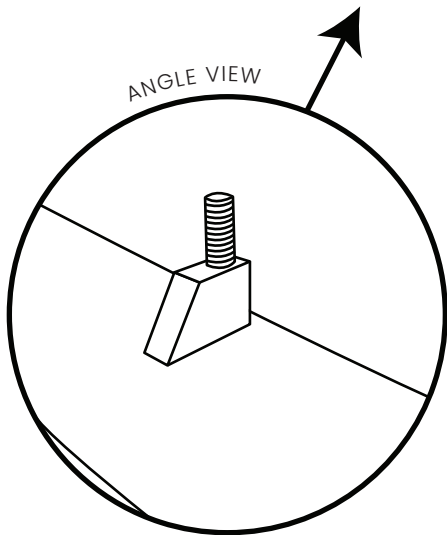

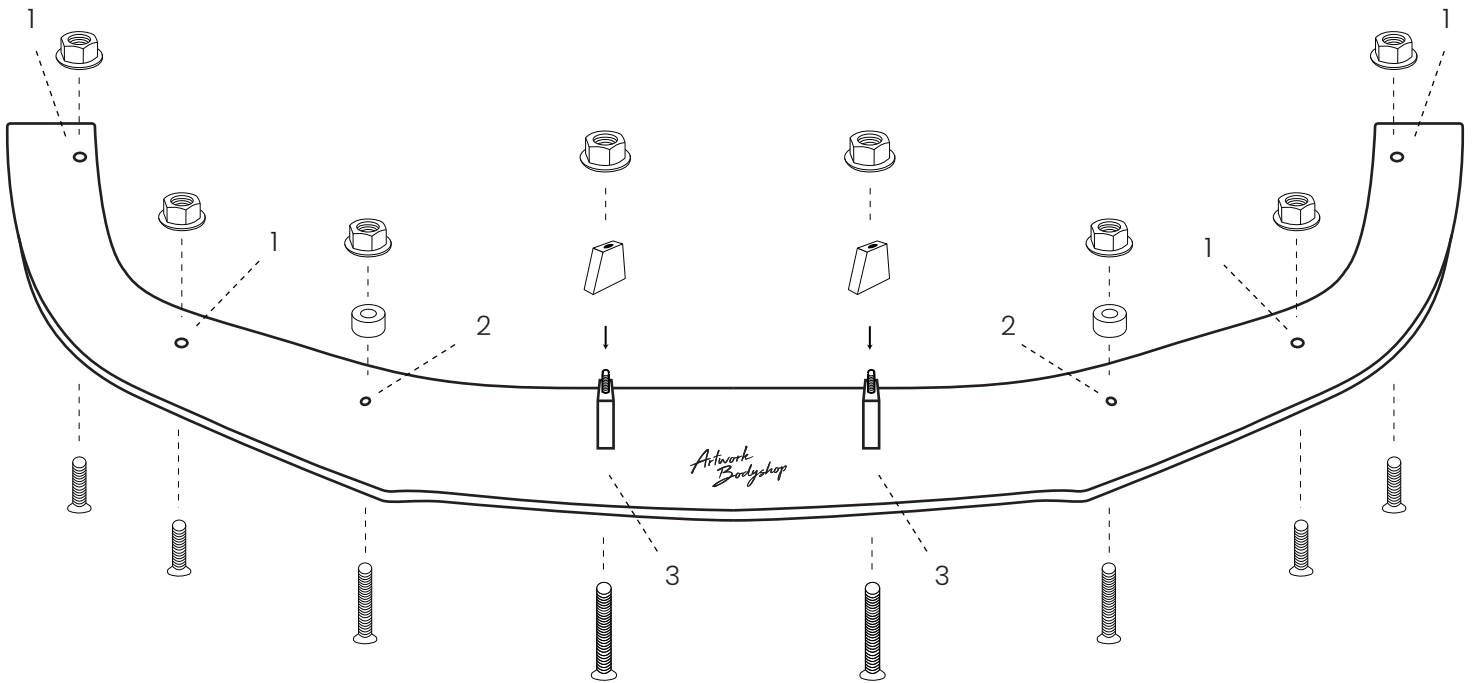

1. M8 Bolts 25mm
2. M8 Bolts 40mm
3. M8 Bolts 55mm

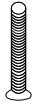

PARTS LIST	
	M8 Bolts 55mm x 2 M8 Bolts 40mm x 2 M8 Bolts 25mm x 4
	M8 Lock Nuts x 8
	3/8 Round Spacers x 2
	3/4 Spacers x 2
	M8 Hex Key x 1

\* INSTALL YOUR BOLT WITH YOUR HEX KEY BY THE BOTTOM OF YOUR LIP

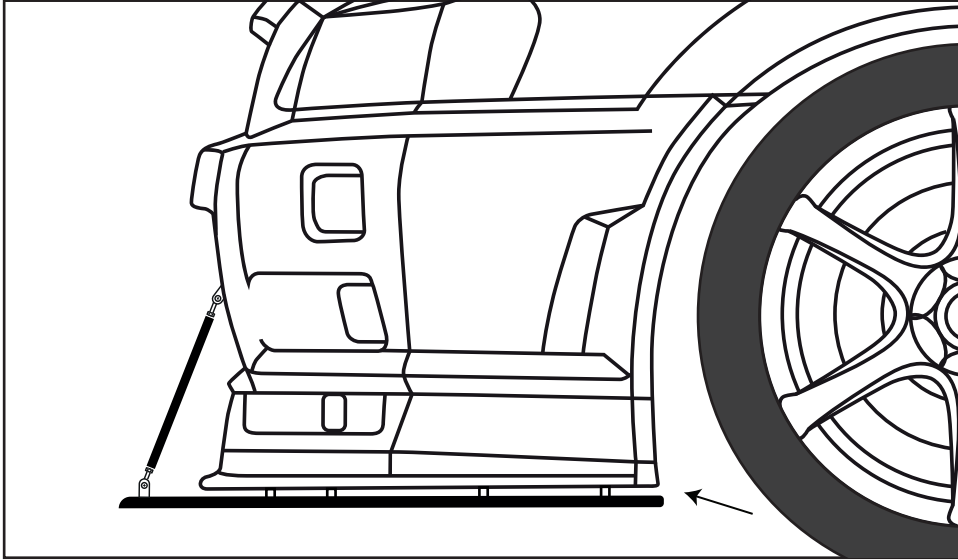

### TOOLS REQUIRED

- ☑ CAR JACK & JACK STANDS
- ☑ PERMANENT MARKER
- ☑ DRILL
- ☑ DRILL BITS 5/16"
- ☑ HARDWARE BAG (INCLUDED)
- ☑ TORX, PHILLIPS, 10MM BOX  
(TO REMOVE YOUR SPLASH GUARD, IF NECESSARY)

### \*\*CAUTION: PROFESSIONAL INSTALLATION IS STRONGLY RECOMMENDED\*\*

1. Jack the front of the car for an easy access (Don't forget to put your jack stands).
2. Align perfectly the lip under the bumper (The tip of the lip should be lined with the corner of your bumper near the wheel, see picture above).
3. With the permanent marker, mark the drill spot on the bumper through the holes of the lip (The lip should not move if you can't reach the bumper with your marker, skip to step #4).
4. Drill in the middle of your marks (or holes) with 5/16" drill bit.
5. Make an easy access to reach the holes inside the bumper.
6. Remove the 10mm bolts on the car where the holes A align.
7. Assemble the lip with hardware (See assembly instructions).
8. Put the lip on the bumper by aligning the bolts through the holes and add the flange nuts inside the bumper.
9. Tight all the remaining hardware with your hex by the bottom of the splitter.
10. Reinstall all removed trims and you're ready to go. Take pictures and send them to [info@artworkbodyshop.com](mailto:info@artworkbodyshop.com) and tag us on social media [@artworkbodyshop](https://www.instagram.com/artworkbodyshop).