

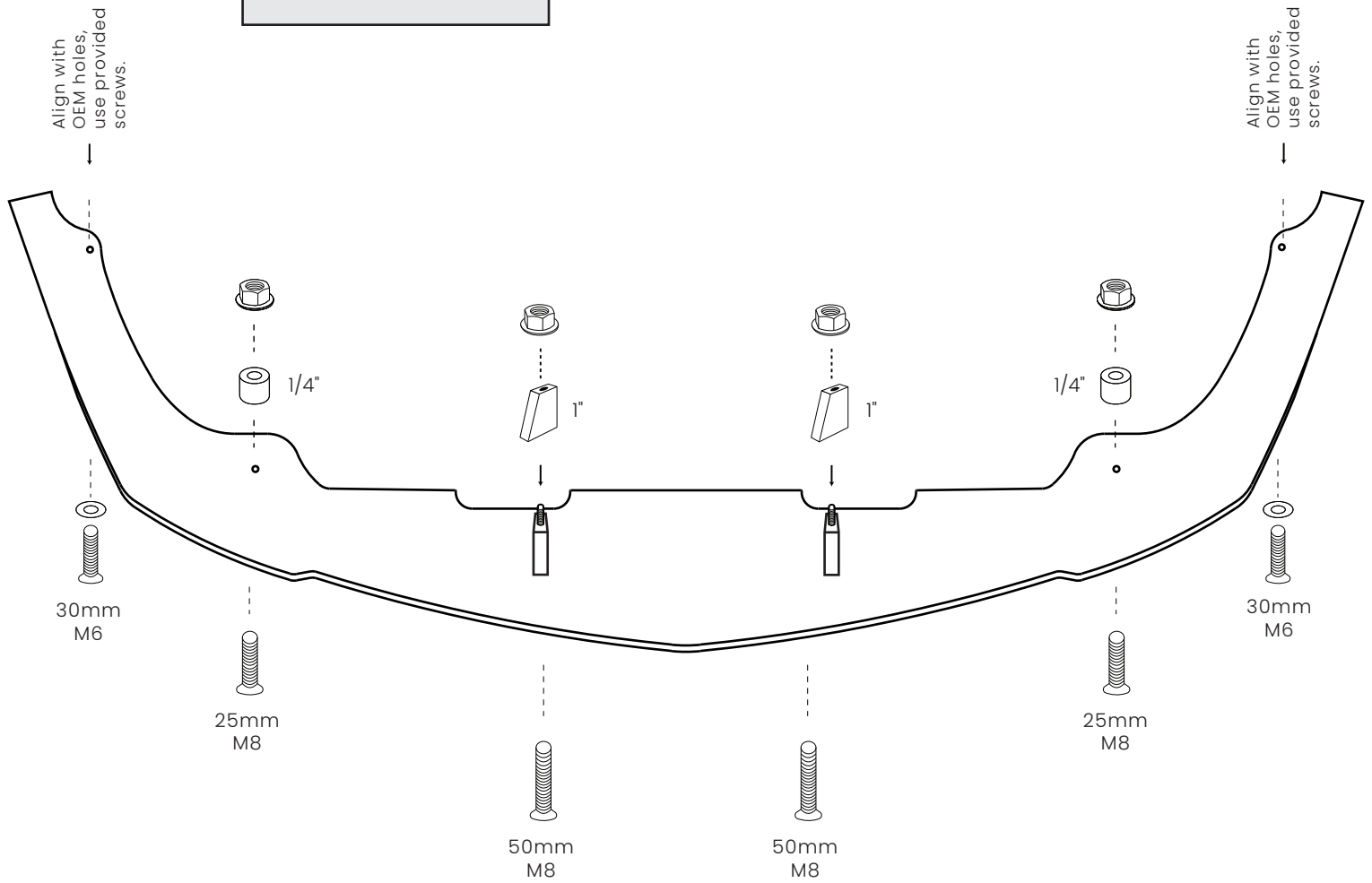



BASE MODEL



PARTS LIST MAY DIFFER ACCORDING TO YOUR MODEL

PARTS LIST

	50mm M8 Bolts x 2 25mm M8 Bolts x 2
	M8 Lock Nuts x 4
	1/4" Round Spacers x 2
	1-1/2" Spacers x 2
	30mm M6 Bolts x 2 M6 Finish Washers x 2
	M8 Hex Key x 1 M6 Hex Key x 1

* Install your bolt with your hex key by the bottom of your lip

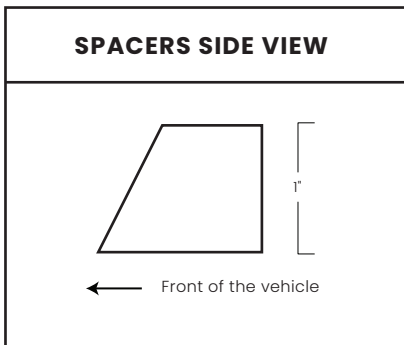

BASE MODEL

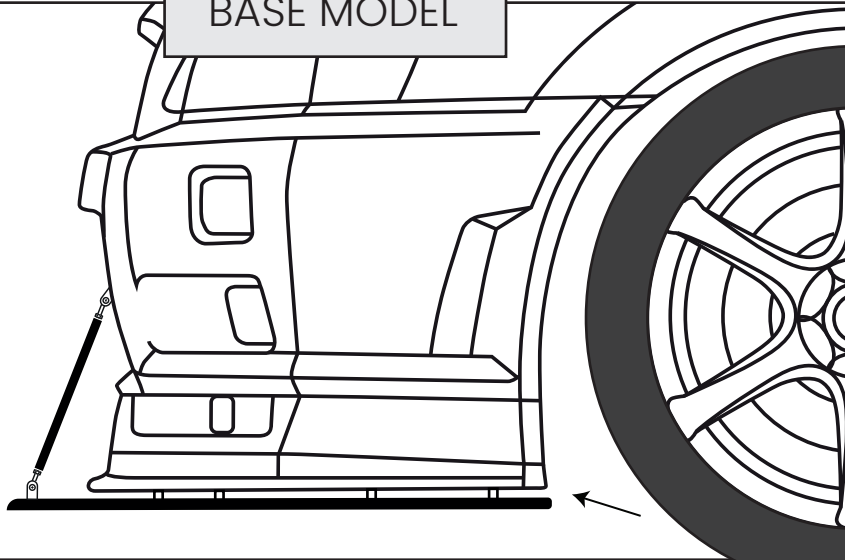

TOOLS REQUIRED

- ☑ CAR JACK & JACK STANDS
- ☑ PERMANENT MARKER
- ☑ DRILL
- ☑ DRILL BITS 5/16
- ☑ HARDWARE BAG (INCLUDED)
- ☑ TORX, PHILLIPS, 10MM BOX
(TO REMOVE YOUR SPLASH GUARD, IF NECESSARY)

****CAUTION: PROFESSIONAL INSTALLATION IS STRONGLY RECOMMENDED****

1. Jack the front of the car for an easy access (don't forget to put your jack stands).
2. Align perfectly the lip under the bumper (the tip of the lip should be lined with the corner of your bumper near the wheel, see picture above).
3. With the permanent marker, mark the drill spot on the bumper through the holes of the lip (the lip should not move if you can't reach the bumper with your marker, skip to step #4).
4. Drill in the middle of your marks (or holes) with 5/16 drill bit.
5. Make an easy access to reach the holes inside the bumper.
6. Assemble the lip with hardware (see assembly instructions).
7. Put the lip on the bumper by aligning the bolts through the holes.
8. Tight all the remaining hardware inside the bumper (nuts & washers), while holding your hex key into the bolt to make sure it won't turn.
9. Reinstall all removed trims and you're ready to rock n roll. Take pictures and send them to **info@artworkbodyshop.com** and don't forget to tag us on social media **@artworkbodyshop**.