

So what's the difference between the **Wing Clipper I**<sup>®</sup> and the **Wing Clipper II**<sup>®</sup>? It's the unusual sizes of the Flying Geese units. With the **Wing Clipper I**<sup>®</sup> unit sizes will all finish to either half inch or whole inch increments: 1" x 2", 1½" x 3", 2" x 4", etc. **Wing Clipper II**<sup>®</sup> unit sizes will finish to either ¼" or ¾" increments: 1¼" x 2½", 1¾" x 3½", etc. Remember that the finished size is the measurement

of the shape after all sewing is complete. These increments fall in between the unit options on the original **Wing Clipper I**<sup>®</sup>. The construction process and trimming are the same, but the trim down lines are engineered to align with the more unusual size units. So with your new **Wing Clipper II**<sup>®</sup> you'll have nine additional Flying Geese units at your disposal.

# Wing Clipper II Basics

The Wing Clipper II tool is used in association with **Traditional Flying Geese** units. These are units that will finish to a width that is twice as wide as it is tall. The process will require a set of squares including:

1 Large Square and 4 Small Squares.

Each time a set is made, there will be a total of four complete Flying Geese Units constructed. By trimming each with the Wing Clipper II tool, the units will measure an exact size and have all seams correctly placed.

A terrific way to construct **Precise Units - Quickly and Accurately!**

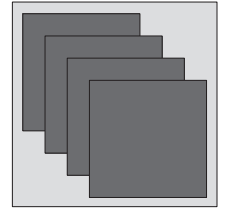
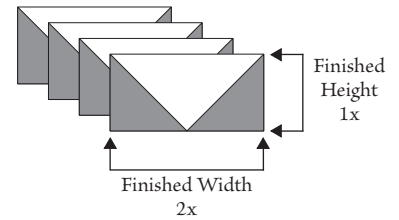

Finished Size of Flying Geese Unit	Cut Size of Flying Geese Unit	Cut Size of LARGE SQUARES Used to Make Large Quarter Square Triangles	Cut size of SMALL SQUARES Used to Make Small Half Square Triangles
$\frac{3}{4}$ " x $1\frac{1}{2}$ "	$1\frac{1}{4}$ x 2"	3"	$1\frac{3}{4}$ "
$1\frac{1}{4}$ " x $2\frac{1}{2}$ "	$1\frac{3}{4}$ " x 3"	4"	$2\frac{1}{4}$ "
$1\frac{3}{4}$ " x $3\frac{1}{2}$ "	$2\frac{1}{4}$ " x 4"	5"	$2\frac{3}{4}$ "
$2\frac{1}{4}$ " x $4\frac{1}{2}$ "	$2\frac{3}{4}$ " x 5"	6"	$3\frac{1}{4}$ "
$2\frac{3}{4}$ " x $5\frac{1}{2}$ "	$3\frac{1}{4}$ " x 6"	7"	$3\frac{3}{4}$ "
$3\frac{1}{4}$ " x $6\frac{1}{2}$ "	$3\frac{3}{4}$ " x 7"	8"	$4\frac{1}{4}$ "
$3\frac{3}{4}$ " x $7\frac{1}{2}$ "	$4\frac{1}{4}$ " x 8"	9"	$4\frac{3}{4}$ "
$4\frac{1}{4}$ " x $8\frac{1}{2}$ "	$4\frac{3}{4}$ " x 9"	10"	$5\frac{1}{4}$ "
$4\frac{3}{4}$ " x $9\frac{1}{2}$ "	$5\frac{1}{4}$ " x 10"	11"	$5\frac{3}{4}$ "

If you have done this in the past, it has been critical to carefully align the raw edges of the small squares with the large square. For this process it is better to nudge the small squares closer toward the center of the large square and have about  $\frac{1}{16}$  of an inch showing between the raw edges of the small and large squares. After constructing a few, you'll know exactly how much to adjust.

**Step 1 - Position** two of the smaller squares right sides together in diagonally opposite corners of the one large square. Nudge them in toward the center just a few threads.

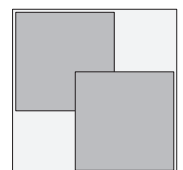

Step 1 - Position

**Step 2 - Mark** two lines, each  $\frac{1}{4}$ " away from the center diagonal. I like to use my **Quilter's Magic Wand™** and a fine line marking tool. The **Quilter's Magic Wand™** keeps my seam allowances from getting too wide and a fine line gives me better accuracy.

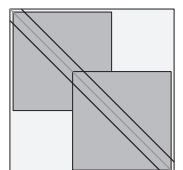

Step 2 - Mark

**Step 3 - Stitch** on both of the drawn lines, then **Trim** between the lines of stitching on the center diagonal.

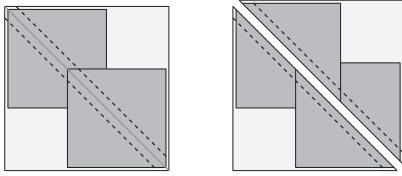

Step 3 - Stitch and Trim

**Step 4 - Press** seams toward the smaller triangles (I do this no matter which is dark or light).

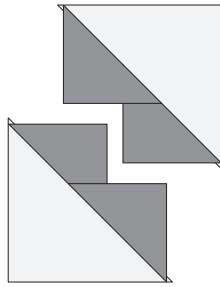

Step 4 - Press

**Step 5 - Position** one small square in the corner of the previously pieced units. Nudge the squares in like you did before.

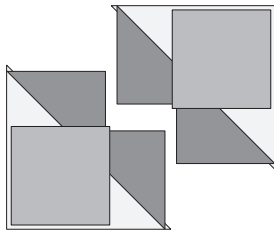

Step 5 - Position

**Step 6 - Mark** two lines, each ¼" away from the center diagonal. Use the **Quilter's Magic Wand™** and fine line marker.

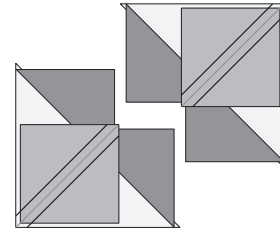

Step 6 - Mark

**Step 7 - Stitch** on both of the drawn lines, then **Trim** between the lines of stitching on the center diagonal.

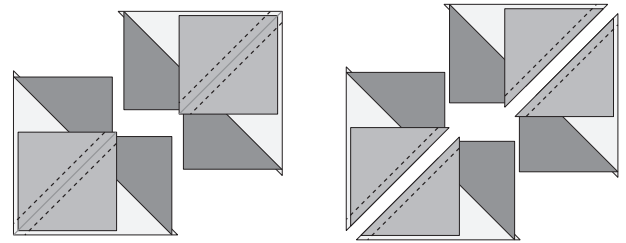

Step 7 - Stitch and Trim

**Step 8 - Press** seams toward the smaller triangles (I do this no matter which is dark or light).

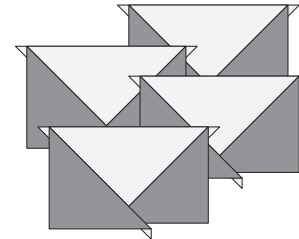

Step 8 - Press

At this point the pieced Flying Geese units are slightly larger than they need to be. You will use the **Wing Clipper® II** to trim them to a precise measurement.

# Wing Clipper® Trim-Down Process

## Right Handed Quilters

**Step 9 - Position** your oversized units horizontally on your cutting mat with the long edge of the center triangle farthest away from you (in the “Valley” position).

**Step 10 - Align** the diagonal guide lines of the **Wing Clipper® II** with the sewn seams of the Flying Geese unit. You’ll automatically be centering the ruler over your pieced unit.

**Step 11 - Trim** up the right side and across the top of the **Wing Clipper® II**, then rotate the Flying Geese unit 180° (half way around).

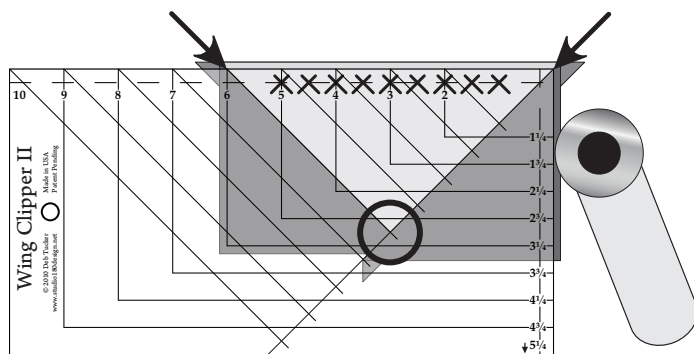

Step 9 to 11 - Position, Align and Trim

**Step 12 - Reposition** the **Wing Clipper®** to align clean-up guidelines with the previously trimmed raw edges and the “X” with the intersection of the seams. Again be sure to have the proper cut sizes aligned for your particular project.

**Step 13 - Trim** again, up the right side and across the top. Each unit will now be precisely sized with all the seams properly positioned for perfect points every time.

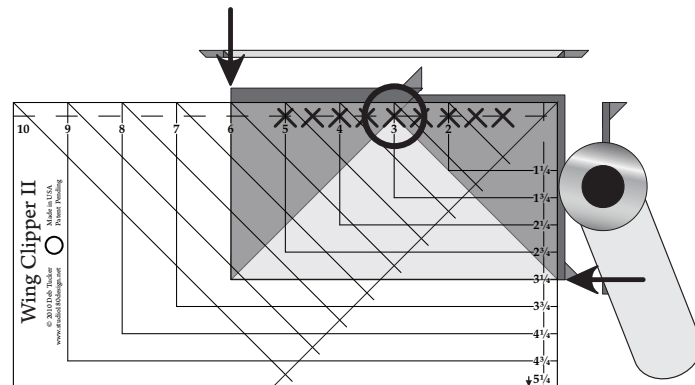

Step 12 & 13 - Reposition and Trim Again

To see an online video tutorial of the **Wing Clipper®** tool and others developed by Deb Tucker and **Studio 180 Design**, visit the video page on our website: [Studio180Design.net](http://Studio180Design.net)

## Additional Wing Clipper® Uses

To see additional ways to use your **Wing Clipper™** tool for making other units, be sure to check out our new **Technique Sheets** and companion video tutorials. The **Pickets and Quickets Technique Sheet** provides two methods to make a rectangular unit that looks like a Flying Geese unit with only one side triangle — like the Pickets on some Picket Fences. In both cases you make your unit oversized and trim to perfection with your **Wing Clipper™** ruler.

## Left Handed Quilters

**Step 9 - Position** your oversized units vertically on your cutting mat with the long edge of the center triangle on the left as shown (with “the geese going East”).

**Step 10 - Align** the diagonal guide lines of the **Wing Clipper®** with the sewn seams of the Flying Geese unit. you'll automatically be centering the ruler over your pieced unit.

**Step 11 - Trim** up the left side and across the top of the **Wing Clipper®**, then rotate the Flying Geese unit 180° (half way around).

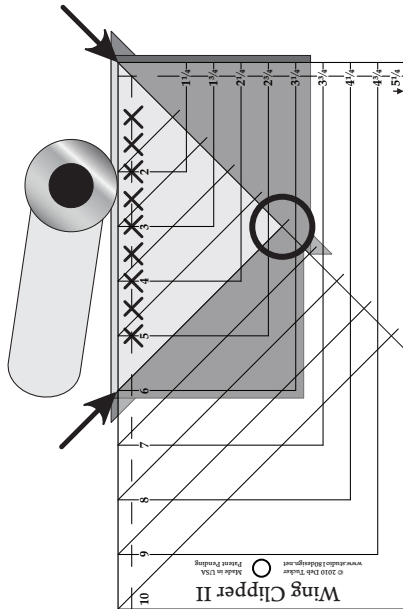

Step 9 to 11 -  
Position, Align and Trim

**Step 12 - Reposition** the **Wing Clipper®** to align the clean-up guidelines with the previously trimmed raw edges and the “X” at the top with the intersection of the seams. Again be sure to have the proper cut sizes aligned for your particular project.

**Step 13 - Trim** again, up the left side and across the top. Each unit will now be precisely sized with all the seams properly positioned for perfect points every time.

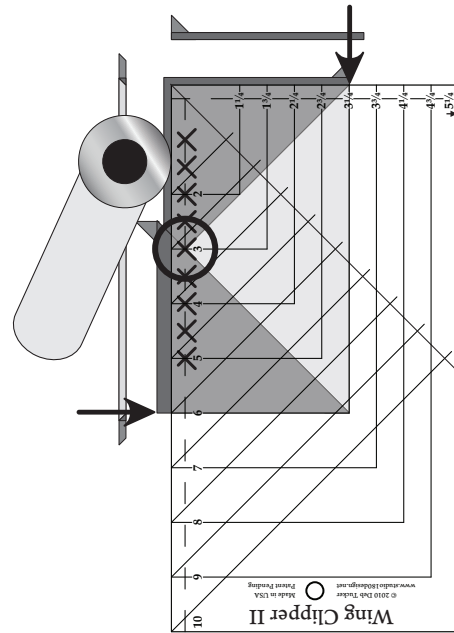

Step 12 & 13 - Reposition and Trim Again

To see an online video tutorial of the **Wing Clipper®** tool and others developed by Deb Tucker and **Studio 180 Design**, visit the video page on our website: [Studio180Design.net](http://Studio180Design.net)

## Additional Wing Clipper® Uses

To see additional ways to use your **Wing Clipper™** tool for making other units, be sure to check out our new **Technique Sheets** and companion video tutorials. The **Pickets and Quickets Technique Sheet** provides two methods to make a rectangular unit that looks like a Flying Geese unit with only one side triangle — like the Pickets on some Picket Fences. In both cases you make your unit oversized and trim to perfection with your **Wing Clipper™** ruler.