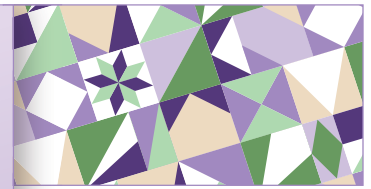


Created by Sarah Furrer  
Studio180Design.Net

# BlockBusters

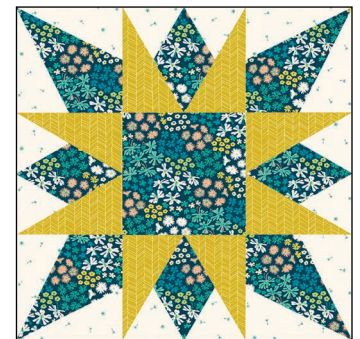
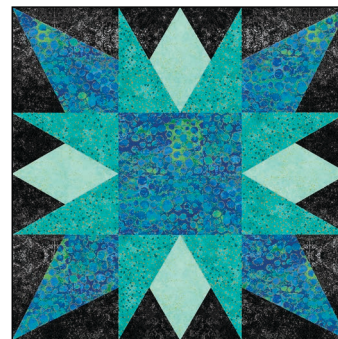
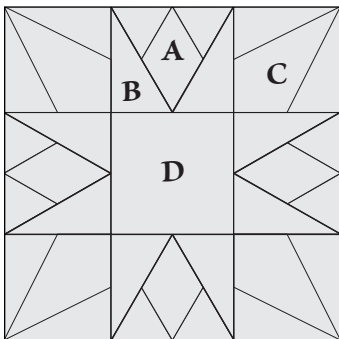
## 60 Degree What?

Made using Studio 180 Design's Star 60™  
and Corner Beam® Tools



BlockBusters 2020: #51  
Difficulty: ★★★★★

All the instruction you need to make the units required for this block came with your Star 60™ and Corner Beam® tools. There are charts, step by step graphics, and directions. Use the charts to find the information you need for the finished size of the units you want to make, follow them through to find what you need to cut to make the units. Then work your way through the instructions.

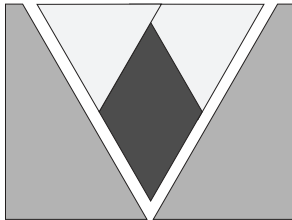


### Cutting Chart

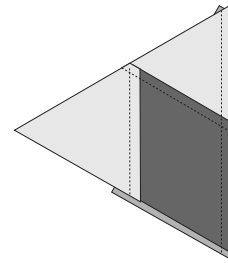
Unit	# of units required	6¼" Block	11" Block	19" Block
A: Star 60	4	Diamond Strips and Side Triangle Strips for a 2" finished Star 60 unit.	Diamond Strips and Side Triangle Strips for a 3½" finished Star 60 unit.	Diamond Strips and Side Triangle Strips for a 6" finished Star 60 unit.
B: Half Triangles	8 (4 rectangles)	2¾" x 3" rectangles cut using step 36 & 37 from the Star 60 instructions.	3½" x 4½" rectangles cut using step 36 & 37 from the Star 60 instructions.	5" x 7" rectangles cut using step 36 & 37 from the Star 60 instructions.
C: Corner Beams	4	2" finished size 2½" cut size	3½" finished size 4" cut size	6" finished size 6½" cut size
D: Center Square	1	2¾" cut size	4½" cut size	7½" cut size
Regular Ruler line for trimming.	1	1⅜" line through Star 60 Points, Second trim 2¾" line.	2¼" line through Star 60 Points, Second trim 4½" line.	3¾" line through Star 60 Points, Second trim 7½" line.

This month you will be using the new Star 60™ tool in the block. You will need to reference the diagrams below to help you with squaring up the units that look like V blocks but are actually made with Star 60™ units. Note that these units will be rectangles **NOT** squares.

To make your north, south, east and west units you need to follow the Star 60™ instructions and make the 4 units of your desired size. Make sure you do the trim in step 11 on the point but do not make the step 12 trim, leave it oversized for now. To add half triangles to the Star 60™ unit lay them out as shown in diagram 1 and then position the Star 60™ unit on top of the side triangle as shown in diagram 2. Make sure that the half triangle is sticking out beyond the trimmed point of the Star 60™ unit. Add the second half triangle to the other side.

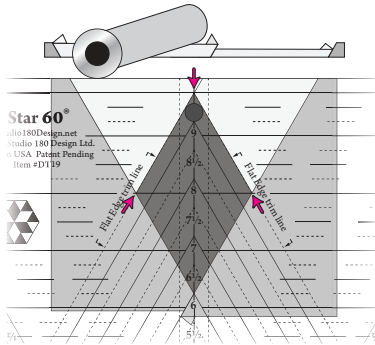


**Diagram 1**

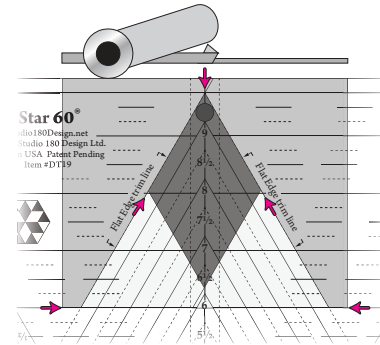


**Diagram 2**

Next use the Flat Edge Trim line to trim the edges that have the diamonds pointing to them as shown in diagrams 3 & 4. Make sure that the center line is going through the opposite point for each trim.



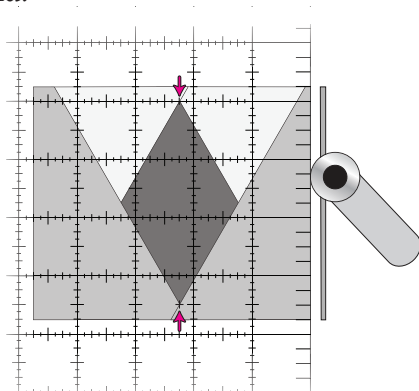
**Diagram 3**



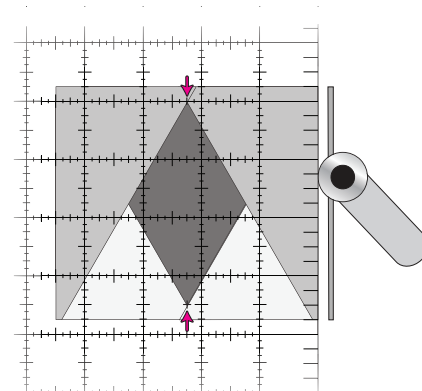
**Diagram 4**

To trim the remaining two sides you will need to use the cutting chart on page 1 to locate your Regular ruler line. The regular ruler line will need to be lined up from point to point on the diamond, make sure that a horizontal line on your ruler is lined up along the trimmed top and bottom edges to make sure you are square, as shown in diagram 5. Trim.

To trim the second side, rotate the unit 180° and line up the same regular ruler line from point to point on the diamond and the second trim number on the trimmed opposite edge of the unit as shown in diagram 6. Trim. You now have the points of your star block. Just make your Corner Beam units as normal and construct the block as you normally would.



**Diagram 5**



**Diagram 6**