

# Needle Valves



# Contents

General Utility Needle Valves  
60N Series



01

Forged Needle Valves  
61N Series



06

Union Bonnet Needle Valves  
62N Series and 62HN Series



10

Rising Plug Valves  
63N Series and 63GN Series



15

High-pressure Needle Valves  
100N Series



19

Outside Screw and Yoke Globe Pattern Needle Valves  
101N Series



23

Integral-Bonnet Needle Valves  
50N Series



27

Nonrotating-stem Needle Valves  
30N Series



30

Toggle Valves  
03N Series



36

# General Utility Needle Valves

## 60N Series

Maximum working pressure:

Stainless steel: 6000 psig (414 bar)

Alloy C-276: 6000 psig (414 bar)

Alloy 400: 5000 psig (345 bar)

Titanium: 3500 psig (241 bar)

Brass: 3000 psig (207 bar)

Working temperature:

PTFE: -65°F to 450°F (-54°C to 232°C)

PEEK: -65°F to 500°F (-54°C to 260°C)

Graphite: -65°F to 1200°F (-54°C to 649°C)



### Features

- ☆ Stem threads are cold rolled for high strength and smooth operation
- ☆ Stem threads above packing, protected from system media
- ☆ Linearly instead of helical movement of the nonrotating lower stem, avoiding galling damage to the seat and tip, as well as reducing the total friction area between the packing and the lower stem

- ☆ Safety back seating seal in fully open position
- ☆ Panel mounting available
- ☆ Steady and durable fastening of the handle by double lock-pins
- ☆ Handle of different colors available for option
- ☆ Leak-tight performance testing for every valve with nitrogen at the maximum working pressure

### Pressure vs. Temperature

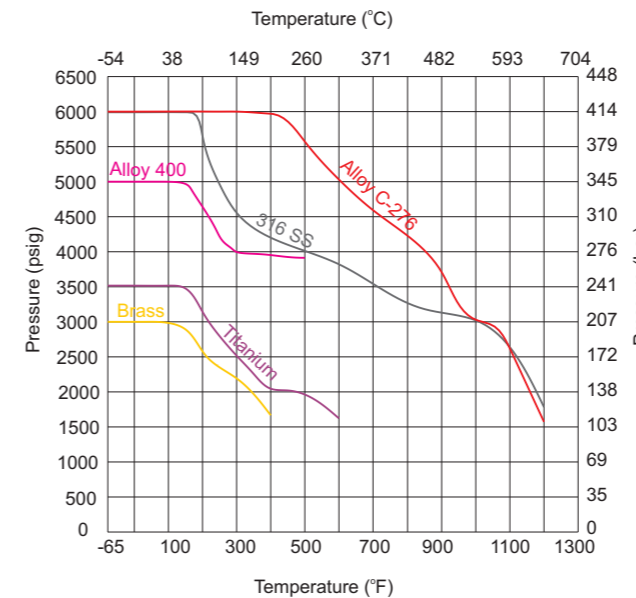

### Flow Data at 100°F (38°C)

Regulating Stem

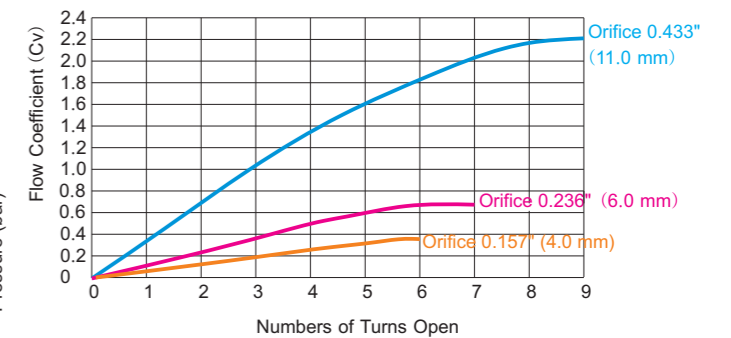

1. Graphs are based on graphite stem packing.
2. 200°F (93°C) max. with PCTFE stem tip (soft tip).
3. Contact the authorized representative or FINELOK for curve graph of other materials.

Standard Materials of Construction

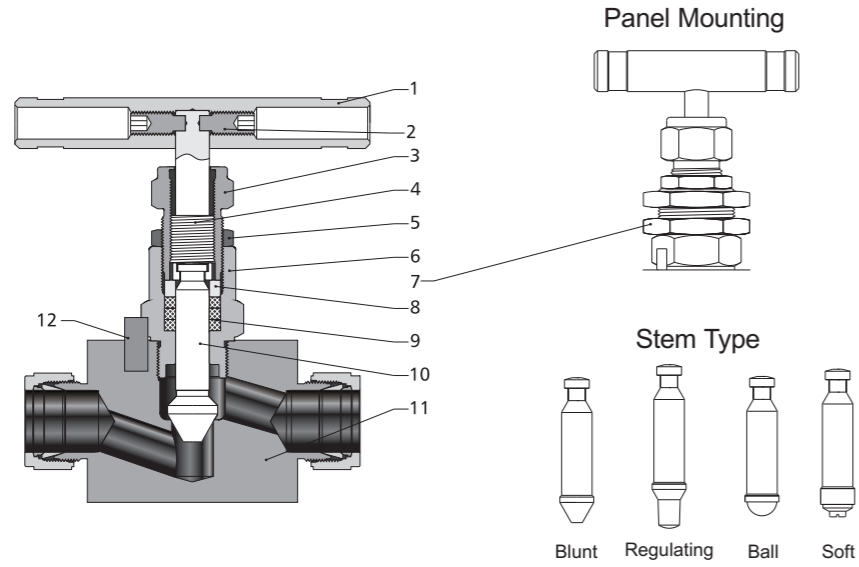

Item	Component	Valve Body Material				
		316 SS	Alloy 400	Titanium	Alloy C-276	Brass
1	Handle	Stainless steel or anodized aluminium or black knob				
2	Set Screw	Nickel cadmium-plated steel				
3	Packing Bolt	316 SS/A276				Brass 360/B16
4	Upper Stem	S17400/A564				
5	Lock Nut	316 SS/B783				Brass 360/B16
6	Bonnet	316 SS/A479	Alloy R-405/B164	Titanium Gr 4/B348	Alloy C-276/B574	Brass 360/B16
7	Panel Nut	316 SS/B783				Brass 360/B16
8	Gland	316 SS/A276				
9	Packing	PTFE or PEEK or graphite				
10	Lower Stem	Chrome-plated 316 SS/A276	Alloy R-405/B164	Titanium Gr 4/B348	Alloy C-276/B574	Chrome-plated 316 SS/A276
		Optional				
11	Body	316 SS/A479 316 SS/A182	Alloy 400/B164, B127,B564	Titanium Gr 4/B348 or titanium Gr 4/B381	Alloy C-276/B564	Brass 360/B16
	Seat	Weld stellite optional				
12	Lock Pin	304 SS/A276				
Lubricant		Molybdenum disulfide-based				

Contact the authorized representative or FINELOK for valves of other materials.

Dimensions

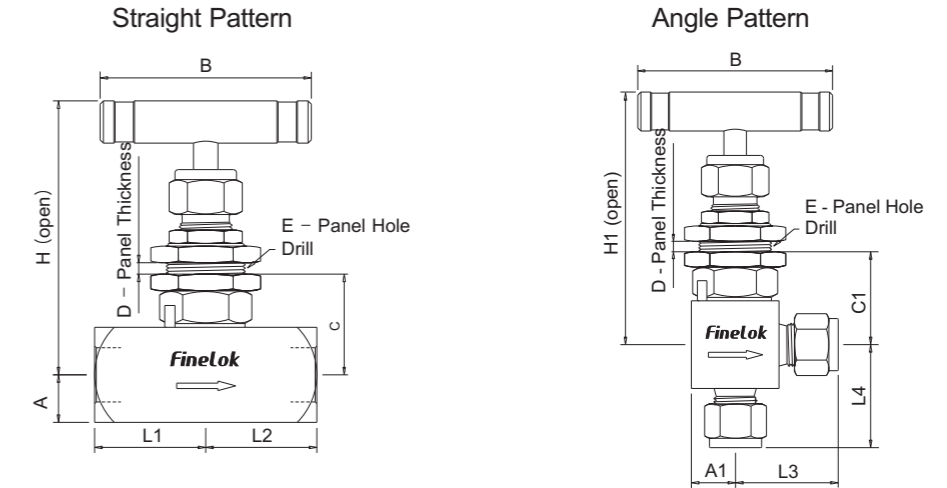

Basic Ordering Number	Connection Type and Size		Orifice in.(mm)	Cv	Dimension, in.(mm)																					
	Inlet	Outlet			L1	L2	L3	L4	A	A1	B	C	C1	D	E	H	H1									
-60N-FNT2-4	1/8 Female NPT	1/8 Female NPT	0.157 (4.0)	0.35	1.00 (25.4)	1.00 (25.4)	1.00 (25.4)	0.563 (14.3)											0.9 (23.0)				2.91 (74.0)			
-60N-FNT4-4	1/4 Female NPT	1/4 Female NPT			1.06 (26.9)	1.06 (26.9)	1.06 (26.9)	1.06 (26.9)																		
-60N-NT4-4	1/4 Male NPT	1/4 Male NPT			1.03 (26.2)	1.03 (26.2)	1.06 (26.9)	1.06 (26.9)																		
-60N-NT6-4	3/8 Male NPT	3/8 Male NPT			1.19 (30.2)	1.19 (30.2)																				
-60N-S4-4	1/4" FINELOK	1/4" FINELOK							0.5 (12.7)	0.5 (12.7)	2.17 (55)	0.84 (21.4)								0.25 (6.4)	0.77 (19.6)	2.85 (72.4)				
-60N-SM6-4	6 mm FINELOK	6 mm FINELOK			1.20 (30.5)	1.20 (30.5)	1.20 (30.5)	1.20 (30.5)												0.84 (21.4)					2.85 (72.4)	
-60N-SM8-4	8 mm FINELOK	8 mm FINELOK																								
-60N-FNT4-6	1/4 Female NPT	1/4 Female NPT					1.12 (28.6)	1.12 (28.6)	0.63 (15.9)																3.56 (90.5)	
-60N-FNT6-6	3/8 Female NPT	3/8 Female NPT																								
-60N-NT6-6	3/8 Male NPT	3/8 Male NPT							1.12 (28.6)																	
-60N-S6-6	3/8" FINELOK	3/8" FINELOK					1.41 (35.8)	1.41 (35.8)	1.32 (33.6)	1.32 (33.6)																
-60N-S8-6	1/2" FINELOK	1/2" FINELOK					1.52 (38.6)	1.52 (38.6)	1.42 (36.1)	1.42 (36.1)																
-60N-SM10-6	10 mm FINELOK	10 mm FINELOK					1.42 (36.1)	1.42 (36.1)	1.33 (33.8)	1.33 (33.8)																
-60N-SM12-6	12 mm FINELOK	12 mm FINELOK					1.52 (38.6)	1.52 (38.6)	1.42 (36.1)	1.42 (36.1)																
-60N-SM14-6	14 mm FINELOK	14 mm FINELOK					1.56 (39.7)	1.56 (39.7)																		
-60N-FS6-6	3/8" FS	3/8" FS																								
-60N-FS8-6	1/2" FS	1/2" FS																								
-60N-MW12-6	12 mm MW	12 mm MW	0.236 (6.0)	0.85	1.13 (28.6)	1.13 (28.6)	1.13 (28.6)	1.13 (28.6)	0.563 (14.3)	0.563 (14.3)	2.5 (63.5)	1.0 (25.4)	1.0 (25.4)	0.38 (9.7)	0.96 (24.4)	3.5 (88.9)	3.5 (88.9)									
-60N-MW14-6	14 mm MW	14 mm MW																								
-60N-MW16-6	16 mm MW	16 mm MW																								
-60N-MB14-6	14 mm MB	14 mm MB																								
-60N-MB16-6	16 mm MB	16 mm MB					1.50 (38.1)	1.50 (38.1)	1.50 (38.1)	1.50 (38.1)																
-60N-UMB14-6	14 mm UMB	14 mm UMB																								
-60N-UMB16-6	16 mm UMB	16 mm UMB					2.92 (74.1)	2.92 (74.1)																		
-60N-MS20-6	M20 x 1.5 Male ISO	M20 x 1.5 Male ISO																								
-60N-MS22-6	M22 x 1.5 Male ISO	M22 x 1.5 Male ISO					1.50 (38.1)	1.50 (38.1)																		

Basic Ordering Number	Connection Type and Size		Orifice in.(mm)	Cv	Dimension, in.(mm)																
	Inlet	Outlet			L1	L2	L3	L4	A	A1	B	C	C1	D	E	H	H1				
-60N-FNT8-11	1/2 Female NPT	1/2 Female NPT	0.433 (11.0)	2.18																	
-60N-FNT12-11	3/4 Female NPT	3/4 Female NPT			1.75 (44.5)	1.75 (44.5)	1.63 (41.3)	1.50 (38.1)													
-60N-NT12-11	3/4 Male NPT	3/4 Male NPT					1.50 (38.1)														
-60N-S12-11	3/4" FINELOK	3/4" FINELOK																			
-60N-SM14-11	14 mm FINELOK	14 mm FINELOK			1.97 (50.0)	1.97 (50.0)	1.61 (41.0)	1.61 (41.0)													
-60N-SM16-11	16 mm FINELOK	16 mm FINELOK																			
-60N-SM18-11	18 mm FINELOK	18 mm FINELOK																			
-60N-MW14-11	14 mm MW	14 mm MW							0.875 (22.2)	0.75 (19.05)	3.5 (88.9)	1.38 (34.9)	1.25 (31.75)	0.38 (9.7)	1.08 (27.5)	4.12 (104.8)		4.0 (101.6)			
-60N-MW16-11	16 mm MW	16 mm MW																			
-60N-FS12-11	3/4" FS	3/4" FS			1.75 (44.5)	1.75 (44.5)															
-60N-MB14-11	14 mm MB	14 mm MB																			
-60N-MB16-11	16 mm MB	16 mm MB																			
-60N-UMB14-11	14 mm UMB	14 mm UMB			2.98 (75.7)	2.98 (75.7)															
-60N-MS27-11	M27 x 2 Male ISO	M27 x 2 Male ISO			1.56 (39.7)	1.56 (39.7)															
-60N-FNT12-15	3/4 Female NPT	3/4 Female NPT	0.591 (15.0)	3.27																	
-60N-FS16-15	1" FS	1" FS			1.75 (44.5)	1.75 (44.5)	1.75 (44.5)	1.75 (44.5)	1.14 (29.0)	0.875 (22.2)	5.0 (127)	1.7 (43.2)	1.43 (36.4)	0.38 (9.7)	1.28 (32.5)	5.0 (127)		4.72 (120)			
-60N-MW25-15	25 mm MW	25 mm MW			1.75 (44.5)	1.75 (44.5)	1.75 (44.5)	1.75 (44.5)													
-60N-MW28-15	28 mm MW	28 mm MW																			
-60N-PS12-15	3/4 PS	3/4 PS																			
-60N-SM20-15	20 mm FINELOK	20 mm FINELOK			2.35 (59.7)	2.35 (59.7)	2.35 (59.7)	2.0 (51.0)													
-60N-SM22-15	22 mm FINELOK	22 mm FINELOK																			
-60N-FNT16-18	1 Female NPT	1 Female NPT			0.708 (18.0)	5.65															
-60N-MW25-18	25 mm MW	25 mm MW					1.97 (50.0)	1.97 (50.0)			1.25 (31.75)		5.5 (140)							5.2 (132)	
-60N-FS16-18	1" FS	1" FS																			
-60N-MW28-18	28 mm MW	28 mm MW																			
-60N-PS12-18	3/4 PS	3/4 PS																			
-60N-PS16-18	1 PS	1 PS																			

1. FINELOK means FINELOK double ferrule tube fittings, FS means fractional tube socket weld, MW means metric tube socket weld, MB means metric tube butt weld, UMB means nut + gasket + metric bulge nipple, ISO means metric thread, PS means pipe socket weld.
2. Sizes and types listed are standard. Other sizes and types are available upon request, refer to the ordering information.
3. Dimensions are shown with FINELOK nuts finger-tightened. All dimensions are for reference only and are subject to change. For dimensions not shown above, please contact the authorized representative or FINELOK.

Ordering Information

SS-60N-S8-SM12-W6WB-GYL-AS

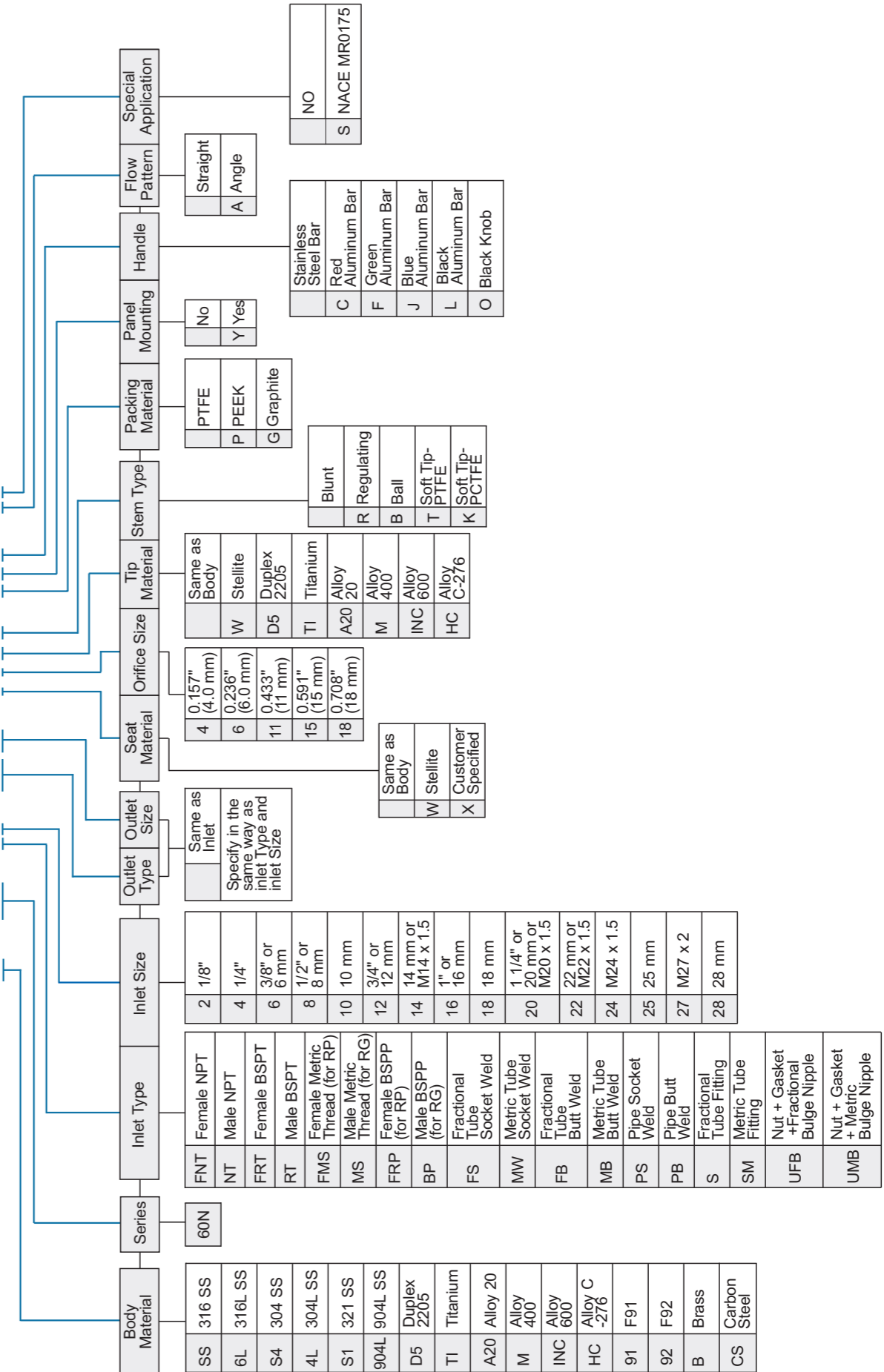

# Forged Needle Valves

## 61N Series

Maximum working pressure:

Stainless steel: 6000 psig (414 bar)

F91: 6000 psig (414 bar)

F92: 6000 psig (414 bar)

Brass: 3000 psig (207 bar)

Working temperature:

PTFE: -65°F to 450°F (-54°C to 232°C)

PEEK: -65°F to 500°F (-54°C to 260°C)

Graphite: -65°F to 1200°F (-54°C to 649°C)



### Features

- ☆ One-piece body construction
- ☆ Two-stem design: thread hardened upper stem and smooth surface hardened lower stem
- ☆ Upper stem thread lubricant isolated from system media
- ☆ Linearly instead of helical movement of the nonrotating lower stem, avoiding galling damage to the seat and tip, as well as reducing the total friction area between the packing and the lower stem
- ☆ Safety back seating seal in fully open position
- ☆ Panel mounting available as an option
- ☆ Steady and durable fastening of the handle by double lock-pins
- ☆ Handle of different colors are available for option
- ☆ Leak-tight performance testing for every valve with nitrogen at the maximum working pressure

### Pressure vs. Temperature

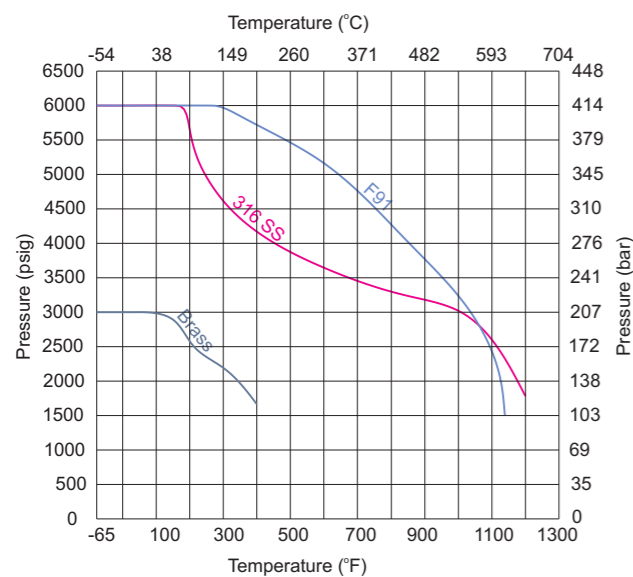

1. Graphs are based on graphite stem packing.
2. 200°F (93°C) max. with PCTFE stem tip (soft tip).
3. Contact the authorized representative or FINELOK for curve graph of other materials.

### Flow Data at 100°F (38°C)

Regulating Stem

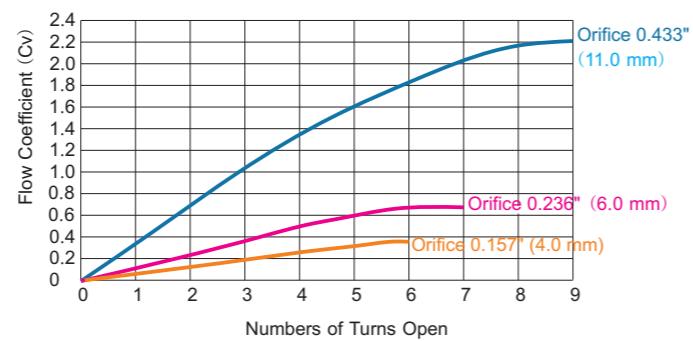

### Standard Materials of Construction

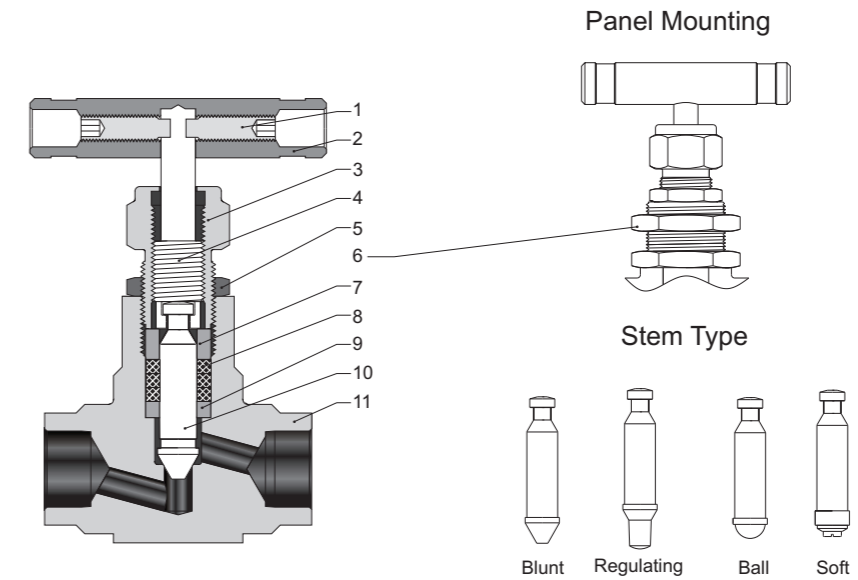

Item	Component	Valve Body Material			
		316 SS	F91	F92	Brass
1	Handle	Stainless steel or anodized aluminium or black knob			
2	Set Screw	Nickel cadmium-plated steel			
3	Packing Bolt	321 SS/A276			
4	Upper Stem	316 SS/A276	F91/A182	F92/A182	Brass 360/B16
5	Lock Nut	316 SS/B783			
6	Panel Nut	316 SS/B783			
7	Gland	316 SS/A276	F91/A182	F92/A182	Brass 360/B16
8	Packing	PTFE or PEEK or graphite			
9	Packing Washer	316 SS/A276	F91/A182	F92/A182	Brass 360/B16
10	Lower Stem	Chrome-plated 316 SS/A276	Chrome-plated F91/A182	Chrome-plated F92/A182	Chrome-plated 316 SS/A276
		Optional			
11	Body	316 SS/A182	F91/A182	F92/A182	Brass 377/B283
	Seat	Weld stellite seat optional			
Lubricant		Molybdenum disulfide-based			



Dimensions

Straight Pattern

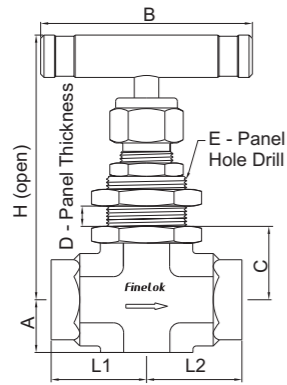

Angle Pattern

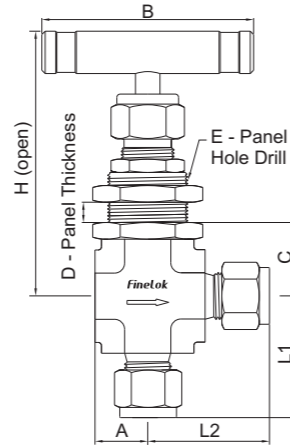

Basic Ordering Number	Connection Type and Size		Orifice in.(mm)	Cv	Dimension, in.(mm)													
	Inlet	Outlet			L1	L2	A	B	C	D	E	H						
-61N-FNT2-4	1/8 Female NPT	1/8 Female NPT	0.157 (4.0)	0.35	1.00 (25.4)	1.00 (25.4)	0.53 (13.5)	2.17 (55)	0.71 (18.0)	0.25 (6.4)	0.77 (19.6)	2.85 (72.5)						
-61N-FNT4-4	1/4 Female NPT	1/4 Female NPT			1.03 (26.2)	1.03 (26.2)												
-61N-S4-4	1/4" FINELOK	1/4" FINELOK			1.22 (30.9)	1.22 (30.9)												
-61N-SM6-4	6 mm FINELOK	6 mm FINELOK			1.25 (31.75)	1.25 (31.75)												
-61N-SM8-4	8 mm FINELOK	8 mm FINELOK			1.19 (30.2)	1.19 (30.2)												
-61N-NT6-4	3/8 Male NPT	3/8 Male NPT																
-61N-FNT4-6	1/4 Female NPT	1/4 Female NPT			1.13 (28.6)	1.13 (28.6)							0.62 (15.8)	2.50 (63.5)	0.87 (22.0)	0.38 (9.7)	0.96 (24.4)	3.38 (85.8)
-61N-FNT6-6	3/8 Female NPT	3/8 Female NPT																
-61N-NT6-6	3/8 Male NPT	3/8 Male NPT																
-61N-S6-6	3/8" FINELOK	3/8" FINELOK			1.44 (36.5)	1.44 (36.5)												
-61N-SM10-6	10 mm FINELOK	10 mm FINELOK	1.53 (38.9)	1.53 (38.9)														
-61N-SM12-6	12 mm FINELOK	12 mm FINELOK	1.56 (39.7)	1.56 (39.7)														
-61N-SM14-6	14 mm FINELOK	14 mm FINELOK	1.26 (32.0)	1.26 (32.0)														
-61N-FNT8-6	1/2 Female NPT	1/2 Female NPT	1.50 (38.1)	1.50 (38.1)														
-61N-NT8-6	1/2 Male NPT	1/2 Male NPT	1.53 (38.9)	1.53 (38.9)														
-61N-S8-6	1/2" FINELOK	1/2" FINELOK																
-61N-FS6-6	3/8" FS	3/8" FS	1.13 (28.6)	1.13 (28.6)	0.85	0.62 (15.8)	2.50 (63.5)	0.87 (22.0)	0.38 (9.7)	0.96 (24.4)	3.38 (85.8)							
-61N-FS8-6	1/2" FS	1/2" FS																
-61N-MW12-6	12 mm MW	12 mm MW																
-61N-MW14-6	14 mm MW	14 mm MW																
-61N-MW16-6	16 mm MW	16 mm MW																
-61N-MB14-6	14 mm MB	14 mm MB	1.50 (38.1)	1.50 (38.1)														
-61N-MB16-6	16 mm MB	16 mm MB																
-61N-UMB14-6	14 mm UMB	14 mm UMB	2.92 (74.1)	2.92 (74.1)														
-61N-UMB16-6	16 mm UMB	16 mm UMB																
-61N-MS20-6	M20 x 1.5 Male ISO	M20 x 1.5 Male ISO	1.50 (38.1)	1.50 (38.1)														
-61N-MS22-6	M22 x 1.5 Male ISO	M22 x 1.5 Male ISO																

Basic Ordering Number	Connection Type and Size		Orifice in.(mm)	Cv	Dimension, in.(mm)							
	Inlet	Outlet			L1	L2	A	B	C	D	E	H
-61N-FNT8-11	1/2 Female NPT	1/2 Female NPT	0.433 (11.0)	2.18	1.56 (39.7)	1.56 (39.7)	0.78 (19.8)	3.5 (88.9)	1.1 (28.3)	0.38 (9.7)	1.08 (27.5)	3.86 (98.0)
-61N-FNT12-11	3/4 Female NPT	3/4 Female NPT										
-61N-NT8-11	1/2 Male NPT	1/2 Male NPT										
-61N-NT12-11	3/4 Male NPT	3/4 Male NPT										
-61N-S12-11	3/4" FINELOK	3/4" FINELOK			1.97 (50.0)	1.97 (50.0)						
-61N-SM14-11	14 mm FINELOK	14 mm FINELOK										
-61N-SM16-11	16 mm FINELOK	16 mm FINELOK										
-61N-SM18-11	18 mm FINELOK	18 mm FINELOK										
-61N-SM20-11	20 mm FINELOK	20 mm FINELOK										
-61N-SM25-11	25 mm FINELOK	25 mm FINELOK										
-61N-MW14-11	14 mm MW	14 mm MW										
-61N-MW16-11	16 mm MW	16 mm MW										
-61N-MW18-11	18 mm MW	18 mm MW										
-61N-FS12-11	3/4" FS	3/4" FS	1.56 (39.7)	1.56 (39.7)	0.591 (15.0)	3.27	1.3 (33.0)	5.0 (127)	1.61 (41.0)	0.38 (9.7)	1.45 (36.8)	6.5 (165)
-61N-PS8-11	1/2 PS	1/2 PS										
-61N-MB14-11	14 mm MB	14 mm MB										
-61N-MB16-11	16 mm MB	16 mm MB										
-61N-UMB14-11	14 mm UMB	14 mm UMB	2.98 (75.7)	2.98 (75.7)								
-61N-UMB16-11	16 mm UMB	16 mm UMB	1.56 (39.7)	1.56 (39.7)								
-61N-MS27-11	M27 x 2 Male ISO	M27 x 2 Male ISO										
-61N-FNT12-15	3/4 Female NPT	3/4 Female NPT										
-61N-FS16-15	1" FS	1" FS										
-61N-MW25-15	25 mm MW	25 mm MW	1.97 (50.0)	1.97 (50.0)								
-61N-MW28-15	28 mm MW	28 mm MW										
-61N-PS12-15	3/4 PS	3/4 PS										
-61N-PB12-15	3/4 PB	3/4 PB										
-61N-S12-15	3/4" FINELOK	3/4" FINELOK										
-61N-S16-15	1" FINELOK	1" FINELOK										
-61N-SM20-15	20 mm FINELOK	20 mm FINELOK	2.35 (59.7)	2.35 (59.7)								
-61N-SM22-15	22 mm FINELOK	22 mm FINELOK										
-61N-SM25-15	25 mm FINELOK	25 mm FINELOK										

1. FINELOK means FINELOK double ferrule tube fittings, FS means fractional tube socket weld, MW means metric tube socket weld, MB means metric tube butt weld, UMB means nut + gasket + metric bulge nipple, ISO means metric thread, PS means pipe socket weld.
2. Sizes and types listed are standard. Other sizes and types are available upon request, refer to the ordering information.
3. Dimensions are shown with FINELOK nuts finger-tightened. All dimensions are for reference only and are subject to change. For dimensions not shown above, please contact the authorized representative or FINELOK.

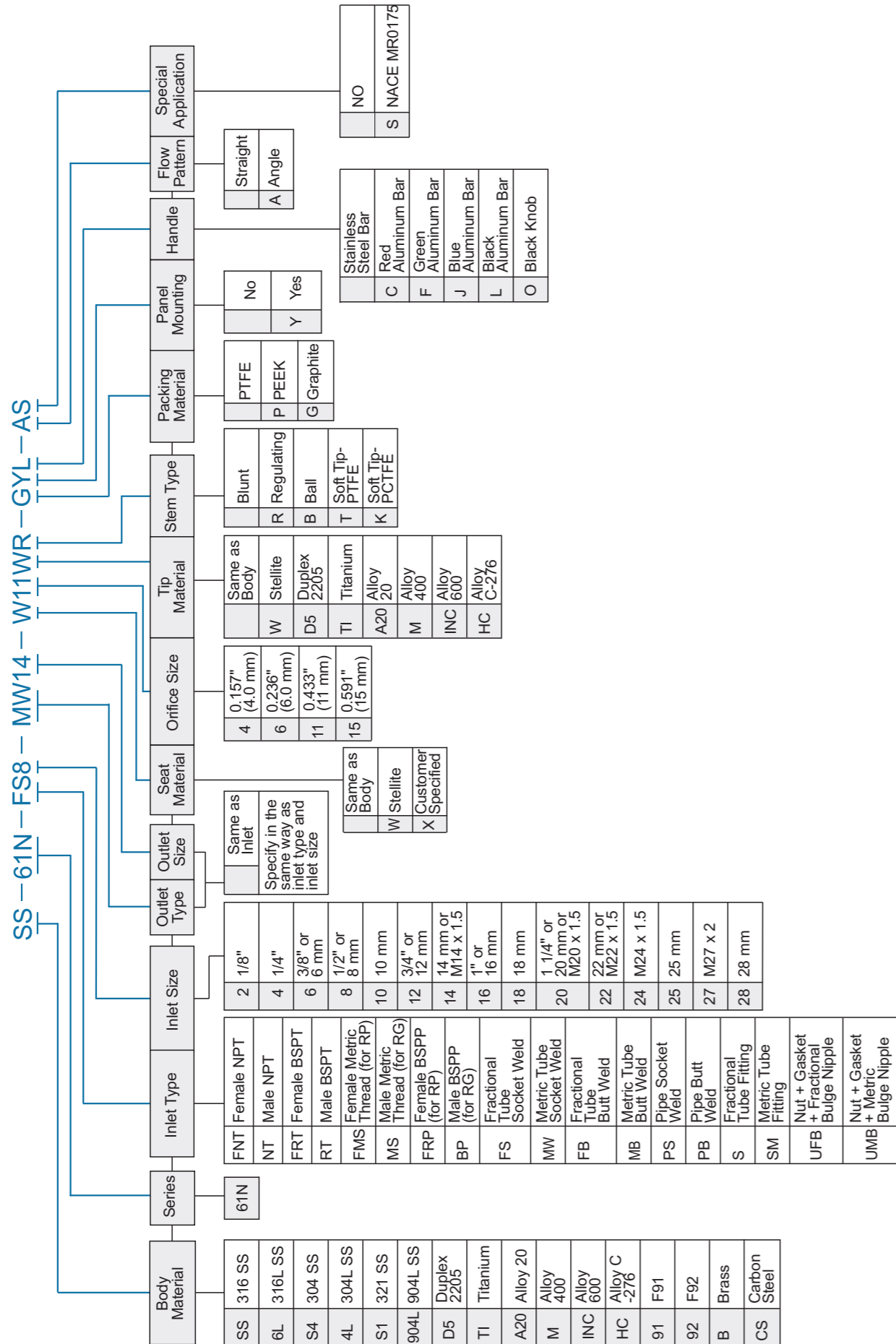

# Union Bonnet Needle Valves

## 62N Series and 62HN Series

Maximum working pressure:  
 62N series  
 Stainless steel: 6000 psig (414 bar)  
 Alloy C-276: 6000 psig (414 bar)  
 Alloy 400: 5000 psig (345 bar)  
 Titanium: 3500 psig (241 bar)  
 62HN series: 10000 psig (689 bar)

Working temperature:  
 PTFE: -65 F to 450 F (-54 C to 232 C)  
 PEEK: -65 F to 500 F (-54 C to 260 C)  
 Graphite: -65 F to 1200 F (-54 C to 649 C)



### Features

- ☆ Two-stem design: thread hardened upper stem and smooth surface hardened lower stem.
- ☆ Accidental valve disassembly disabled by union bonnet construction
- ☆ Upper stem thread lubricant isolated from system media
- ☆ Linearly instead of helical movement of the nonrotating lower stem, avoiding galling damage to the seat and tip, as well as reducing the total friction area between the packing and the lower stem
- ☆ Safety back seating seal in fully open position
- ☆ Panel mounting available as an option
- ☆ Steady and durable fastening of the handle by double lock-pins
- ☆ Handle of different colors available for option
- ☆ Leak-tight performance testing for every valve with nitrogen at the maximum working pressure, but not higher than 6000 psig

### Pressure vs. Temperature

62N Series

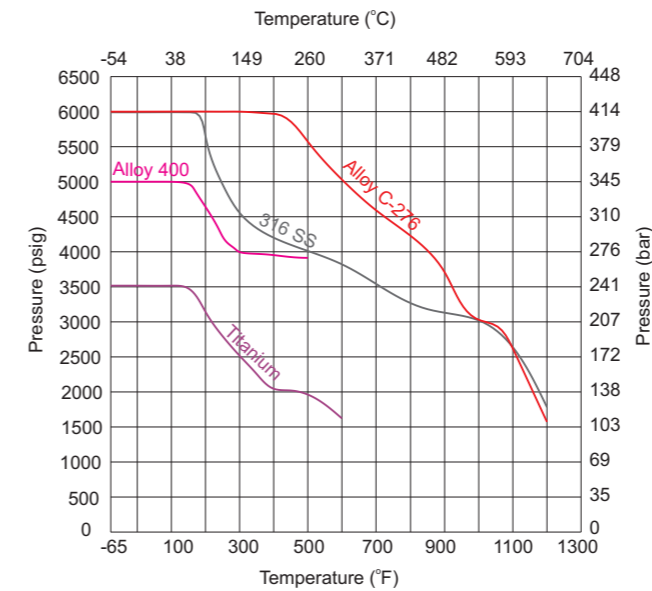

62NH Series

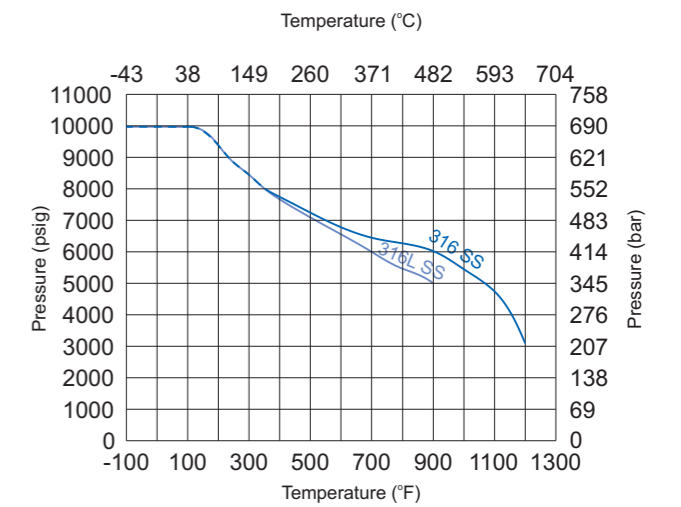

1. Graphs are based on graphite stem packing.
2. 200°F (93°C) max. with PCTFE stem tip (soft tip).
3. Contact the authorized representative or FINELOK for curve graph of other materials.

### Flow Data at 100°F (38°C)

Regulating Stem

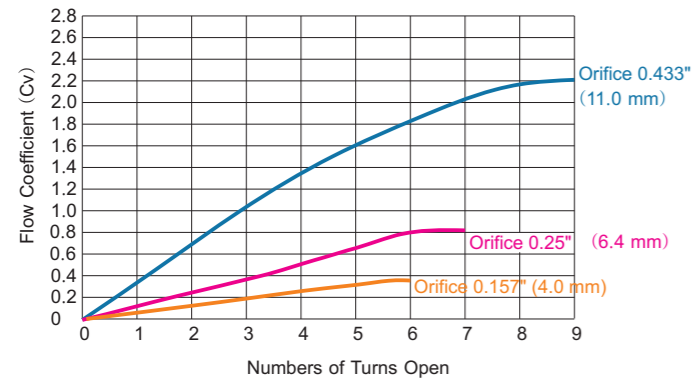

### Standard Materials of Construction

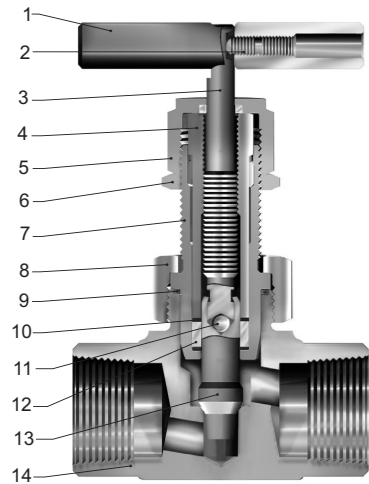

#### Stem Type

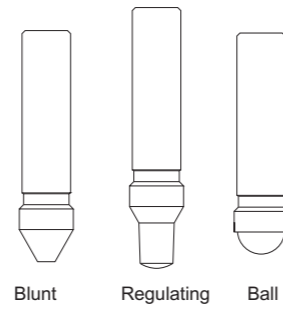

Item	Component	Valve Body Material			
		316 SS	Alloy 400	Titanium	Alloy C-276
1	Handle	Stainless steel or anodized aluminum or black knob			
2	Set Screw	Nickel cadmium-plated steel			
3	Upper Stem	316 SS/A276			
4	Stem Guide	416 SS/A581			
5	Lock Nut	316 SS/A276			
6	Panel Nut	316 SS/B783			
7	Bonnet	316 SS/A479	Alloy R-405/B164	Titanium Gr 4/B348	Alloy C-276/B574
8	Union Nut	316 SS/A276			
9	Bonnet Seal	316 SS/A479	Alloy R-405/B164	Titanium Gr 4/B348	Alloy C-276/B574
10	Packing Washer	316 SS/A479	Alloy R-405/B164	Titanium Gr 4/B348	Alloy C-276/B574
11	Ball	440C			
12	Packing	PTFE or PEEK or graphite			
13	Lower Stem	Chrome-plated 316 SS/A276	Alloy R-405/B164	Titanium Gr 4/B348	Alloy C-276/B574
		Optional			
14	Body	316 SS/A182	Alloy 400/B164, B127, B564	Titanium Gr 4/B348 or titanium Gr 4/B381	Alloy C-276/B564
	Seat	Weld stellite optional			
	Lubricant	Molybdenum disulfide-based			

### Dimensions of 62N Series

#### Straight Pattern

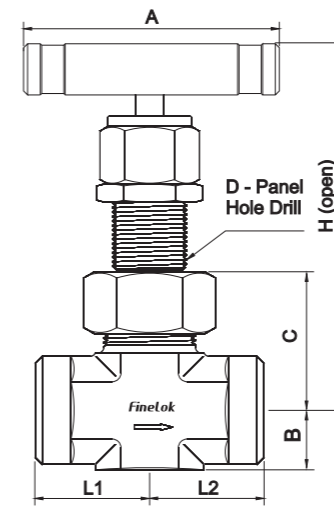

#### Angle Pattern

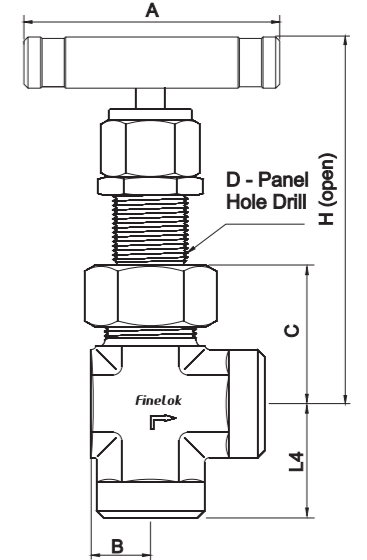

Basic Ordering Number	Connection Type and Size		Orifice in.(mm)	Cv	Dimension, in.(mm)												
	Inlet	Outlet			L1	L2	L3	L4	A	B	C	D	H				
-62N-FNT2-4	1/8 Female NPT	1/8 Female NPT	0.157 (4.0)	0.35	1.00 (25.4)	1.00 (25.4)											
-62N-FNT4-4	1/4 Female NPT	1/4 Female NPT			1.03 (26.2)	1.03 (26.2)	0.89 (22.6)										
-62N-NT4-FNT4-4	1/4 Male NPT	1/4 Female NPT			1.00 (25.4)	1.03 (26.2)											
-62N-NT4-4	1/4 Male NPT	1/4 Male NPT			1.00 (25.4)	1.00 (25.4)	1.00 (25.4)	1.00 (25.4)									
-62N-NT6-4	3/8 Male NPT	3/8 Male NPT															
-62N-FRP4-4	1/4 Female BSPP	1/4 Female BSPP			1.03 (26.2)	1.03 (26.2)	0.89 (22.6)			1.75 (44.5)	0.39 (9.9)	1.09 (27.7)	19/32 (15.1)	3.04 (77.2)			
-62N-NT4-S4-4	1/4 Male NPT	1/4" FINELOK			1.00 (25.4)	1.22 (30.9)											
-62N-FNT4-S4-4	1/4 Female NPT	1/4" FINELOK			1.03 (26.2)	1.22 (30.9)											
-62N-S4-4	1/4" FINELOK	1/4" FINELOK					1.16 (29.5)										
-62N-SM6-4	6 mm FINELOK	6 mm FINELOK					1.22 (30.9)	1.22 (30.9)		1.48 (37.6)							
-62N-SM8-4	8 mm FINELOK	8 mm FINELOK															
-62N-FS4-4	1/4" FS	1/4" FS					0.91 (23.1)	0.91 (23.1)									
-62N-FO4-4	1/4" Male FO	1/4" Male FO					1.03 (26.2)	1.03 (26.2)	0.88 (22.4)	1.19 (30.2)							
-62N-FR4-4	1/4" Male FR	1/4" Male FR															
-62N-FNT4-6	1/4 Female NPT	1/4 Female NPT	0.25 (6.4)	0.8			1.0 (25.4)										
-62N-FNT6-6	3/8 Female NPT	3/8 Female NPT			1.13 (28.6)	1.13 (28.6)	1.13 (28.6)										
-62N-NT6-6	3/8 Male NPT	3/8 Male NPT					1.06 (26.9)										
-62N-NT8-6	1/2 Male NPT	1/2 Male NPT			1.50 (38.1)	1.50 (38.1)	1.25 (31.8)	1.50 (38.1)	2.50 (63.5)	0.50 (12.7)	1.34 (34.0)	25/32 (19.8)	3.70 (94)				
-62N-S6-6	3/8" FINELOK	3/8" FINELOK			1.41 (35.9)	1.41 (35.9)	1.29 (32.8)	1.66 (42.2)									
-62N-S8-6	1/2" FINELOK	1/2" FINELOK			1.52 (38.6)	1.52 (38.6)	1.40 (35.6)	1.65 (41.9)									
-62N-SM10-6	10 mm FINELOK	10 mm FINELOK			1.42 (36.1)	1.42 (36.1)	1.30 (33.0)	1.55 (39.4)									

1. FINELOK means FINELOK double ferrule tube fittings, FS means fractional tube socket weld, MW means metric tube socket weld, MB means metric tube butt weld, UMB means nut + gasket + metric bulge nipple, ISO means metric thread, PS means pipe socket weld.
2. Sizes and types listed are standard. Other sizes and types are available upon request, refer to the ordering information.
3. Dimensions are shown with FINELOK nuts finger-tightened. All dimensions are for reference only and are subject to change. For dimensions not shown above, please contact the authorized representative or FINELOK.



Basic Ordering Number	Connection Type and Size		Orifice in.(mm)	Cv	Dimension, in.(mm)									
	Inlet	Outlet			L1	L2	L3	L4	A	B	C	D	H	
-62N-SM12-6	12 mm FINELOK	12 mm FINELOK	0.25 (6.4)	0.8	1.52 (38.6)	1.52 (38.6)	1.40 (35.6)	1.65 (41.9)	2.50 (63.5)	0.50 (12.7)	1.34 (34.0)	25/32 (19.8)	3.70 (94)	
-62N-SM14-6	14 mm FINELOK	14 mm FINELOK												
-62N-SM16-6	16 mm FINELOK	16 mm FINELOK												
-62N-FS6-6	3/8" FS	3/8" FS												
-62N-FS8-6	1/2" FS	1/2" FS												
-62N-PS4-6	1/4 PS	1/4 PS												
-62N-MW12-6	12 mm MW	12 mm MW												
-62N-MW14-6	14 mm MW	14 mm MW												
-62N-MW16-6	16 mm MW	16 mm MW												
-62N-MB14-6	14 mm MB	14 mm MB												
-62N-MB16-6	16 mm MB	16 mm MB												
-62N-UMB14-6	14 mm UMB	14 mm UMB												
-62N-MS20-6	M20 x 1.5 Male ISO	M20 x 1.5 Male ISO												
-62N-MS22-6	M22 x 1.5 Male ISO	M22 x 1.5 Male ISO												
-62N-FNT8-11	1/2 Female NPT	1/2 Female NPT	0.433 (11.0)	2.2	1.56 (39.6)	1.56 (39.6)	1.31 (33.3)	1.56 (39.6)	3.50 (88.9)	0.78 (19.8)	1.91 (48.5)	1 1/32 (26.2)	4.85 (123)	
-62N-FNT12-11	3/4 Female NPT	3/4 Female NPT			1.63 (41.3)	1.63 (41.3)								
-62N-FNT16-11	1 Female NPT	1 Female NPT			1.81 (46.0)	1.81 (46.0)								
-62N-NT12-11	3/4 Male NPT	3/4 Male NPT			1.63 (41.3)	1.63 (41.3)								
-62N-S8-11	1/2" FINELOK	1/2" FINELOK												
-62N-S12-11	3/4" FINELOK	3/4" FINELOK												
-62N-SM14-11	14 mm FINELOK	14 mm FINELOK			1.97 (50.0)	1.97 (50.0)	1.68 (42.7)	2.08 (52.8)						
-62N-SM16-11	16 mm FINELOK	16 mm FINELOK												
-62N-SM18-11	18 mm FINELOK	18 mm FINELOK												
-62N-SM20-11	20 mm FINELOK	20 mm FINELOK												
-62N-MW14-11	14 mm MW	14 mm MW												
-62N-MW16-11	16 mm MW	16 mm MW												
-62N-FS8-11	1/2" FS	1/2" FS			1.56 (39.7)	1.56 (39.7)	1.31 (33.3)	1.69 (42.9)						
-62N-FS12-11	3/4" FS	3/4" FS												
-62N-MB14-11	14 mm MB	14 mm MB												
-62N-MB16-11	16 mm MB	16 mm MB												
-62N-UMB14-11	14 mm UMB	14 mm UMB	2.98 (75.7)	2.98 (75.7)										

1. FINELOK means FINELOK double ferrule tube fittings, FS means fractional tube socket weld, MW means metric tube socket weld, MB means metric tube butt weld, UMB means nut + gasket + metric bulge nipple, ISO means metric thread, PS means pipe socket weld.
2. Sizes and types listed are standard. Other sizes and types are available upon request, refer to the ordering information.
3. Dimensions are shown with FINELOK nuts finger-tightened. All dimensions are for reference only and are subject to change. For dimensions not shown above, please contact the authorized representative or FINELOK.

### Dimensions of 62HN Series

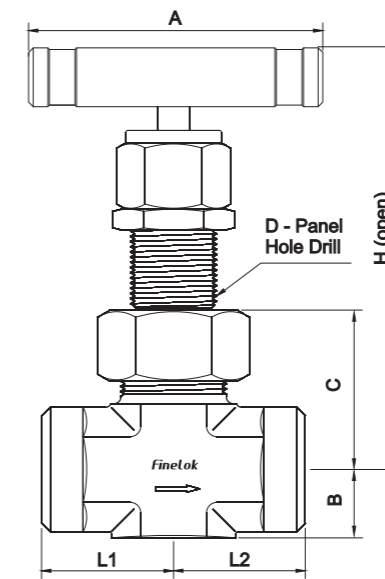

Basic Ordering Number	Connection Type and Size		Orifice in.(mm)	Cv	Dimension, in.(mm)													
	Inlet	Outlet			L1	L2	A	B	C	D	H							
-62HN-FNT2-4	1/8 Female NPT	1/8 Female NPT	0.157 (4.0)	0.35	1.125 (28.58)	1.125 (28.58)	2.5 (63.5)	0.5 (12.7)	1.34 (34.1)	25/32 (19.8)	3.31 (84.1)							
-62HN-FNT4-4	1/4 Female NPT	1/4 Female NPT																
-62HN-NT4-FNT4-4	1/4 Male NPT	1/4 Female NPT																
-62HN-NT4-4	1/4 Male NPT	1/4 Male NPT																
-62HN-NT6-4	3/8 Male NPT	3/8 Male NPT																
-62HN-NT4-S4-4	1/4 Male NPT	1/4" FINELOK																
-62HN-FNT4-S4-4	1/4 Female NPT	1/4" FINELOK																
-62HN-S4-4	1/4" FINELOK	1/4" FINELOK																
-62HN-SM6-4	6 mm FINELOK	6 mm FINELOK																
-62HN-SM8-4	8 mm FINELOK	8 mm FINELOK																
-62HN-FS4-4	1/4" FS	1/4" FS																
-62HN-FNT4-6	1/4 Female NPT	1/4 Female NPT			0.25 (6.4)	0.86						1.56 (39.6)	1.56 (39.6)	3.50 (88.9)	0.63 (16.0)	1.81 (46.0)	1 1/32 (26.2)	4.13 (105)
-62HN-NT8-6	1/2 Male NPT	1/2 Male NPT																
-62HN-FNT8-6	1/2 Female NPT	1/2 Female NPT																
-62HN-NT8-FNT8-6	1/2 Male NPT	1/2 Female NPT																
-62HN-S8-6	1/2" FINELOK	1/2" FINELOK																
-62HN-SM12-6	12 mm FINELOK	12 mm FINELOK																
-62HN-FS8-6	1/2" FS	1/2" FS																
-62HN-MW12-6	12 mm MW	12 mm MW																
			1.63 (41.4)	1.63 (41.4)									4.13 (105)					
			1.97 (50.0)	1.97 (50.0)									4.25 (108)					
			1.56 (39.7)	1.56 (39.7)														

1. FINELOK means FINELOK double ferrule tube fittings, FS means fractional tube socket weld, MW means metric tube socket weld, MB means metric tube butt weld, UMB means nut + gasket + metric bulge nipple, ISO means metric thread, PS means pipe socket weld.
2. Sizes and types listed are standard. Other sizes and types are available upon request, refer to the ordering information.
3. Dimensions are shown with FINELOK nuts finger-tightened. All dimensions are for reference only and are subject to change. For dimensions not shown above, please contact the authorized representative or FINELOK.

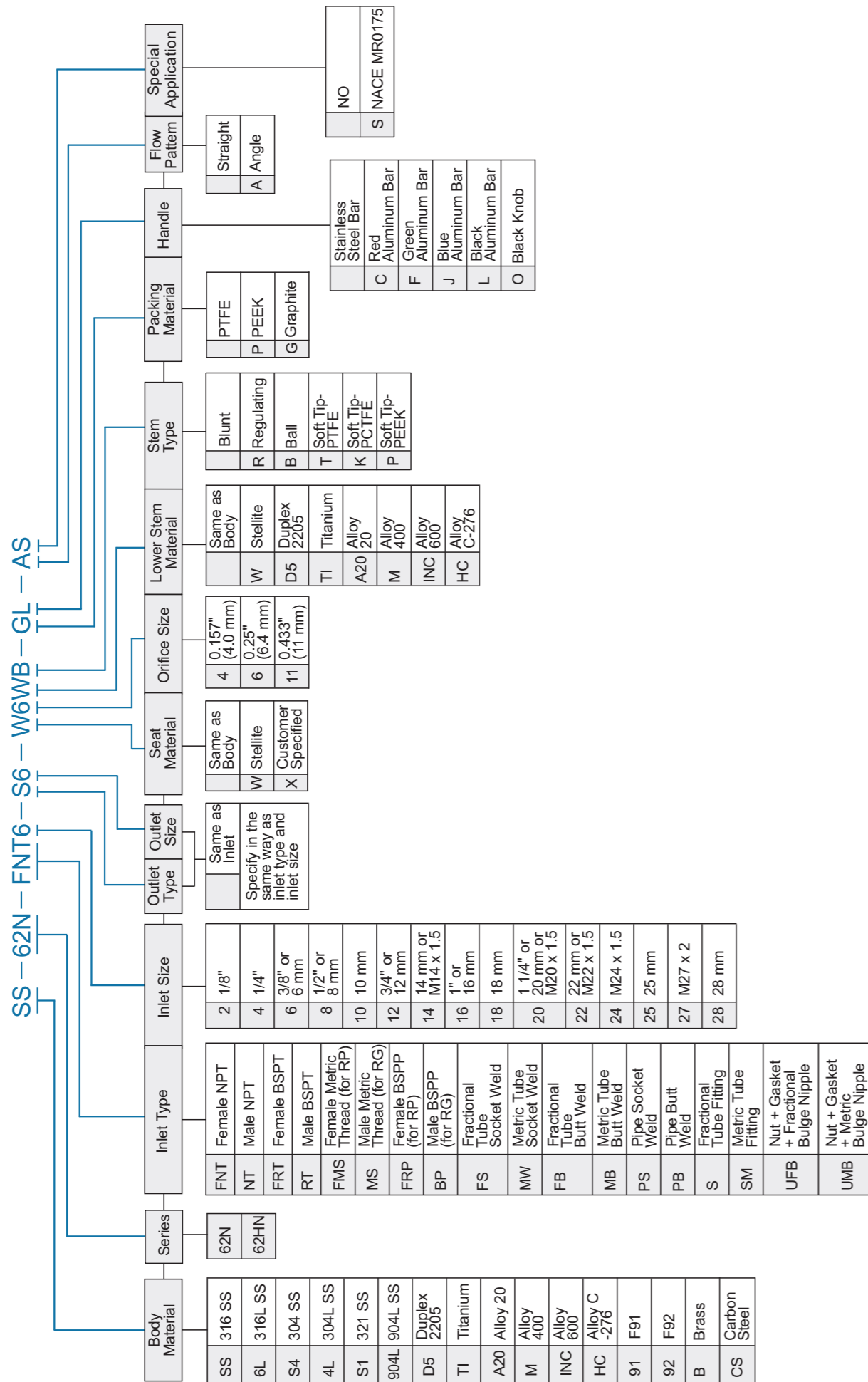

# Rising Plug Valves

## 63N Series and 63GN Series

Maximum working pressure:

Stainless steel: 6000 psig (414 bar)

Alloy 400: 5000 psig (345 bar)

Working temperature:

Acetal: -20°F to 250°F (-28°C to 121°C)

PEEK: -20°F to 400°F (-28°C to 204°C)

PFA: -20°F to 400°F (-28°C to 204°C)



### Features

- ☆ Nonrotating stem for longer seat life
- ☆ Roddable, straight through flow path for maximum flow with minimum pressure drop
- ☆ Stem thread lubricant isolated from system media
- ☆ Replaceable seat and stem tip design
- ☆ Stem thread protected from outside contamination by PTFE ring in the gland
- ☆ Panel mounting available as an option
- ☆ Steady and durable fastening of the handle by double lock-pins
- ☆ Handle of different colors available for option
- ☆ Leak-tight performance testing for every valve with nitrogen at the maximum working pressure

### Pressure vs. Temperature

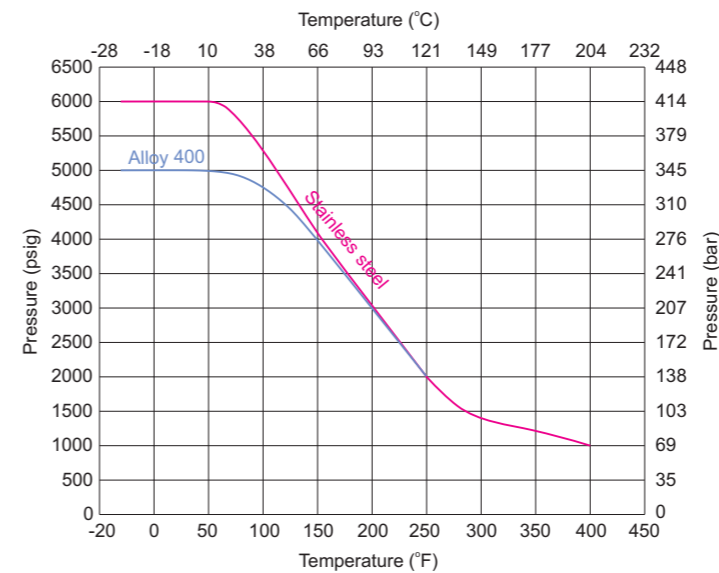

### Flow Data at 100°F (38°C)

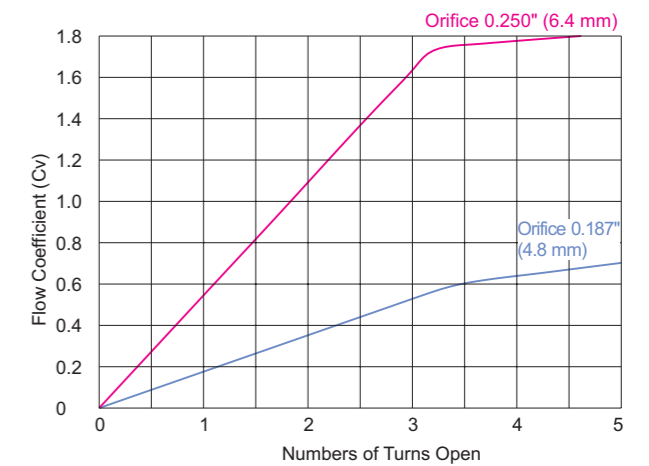

1. Graphs are based on PEEK seat.
2. Contact the authorized representative or FINELOK for curve graph of other materials.

### Standard Materials of Construction

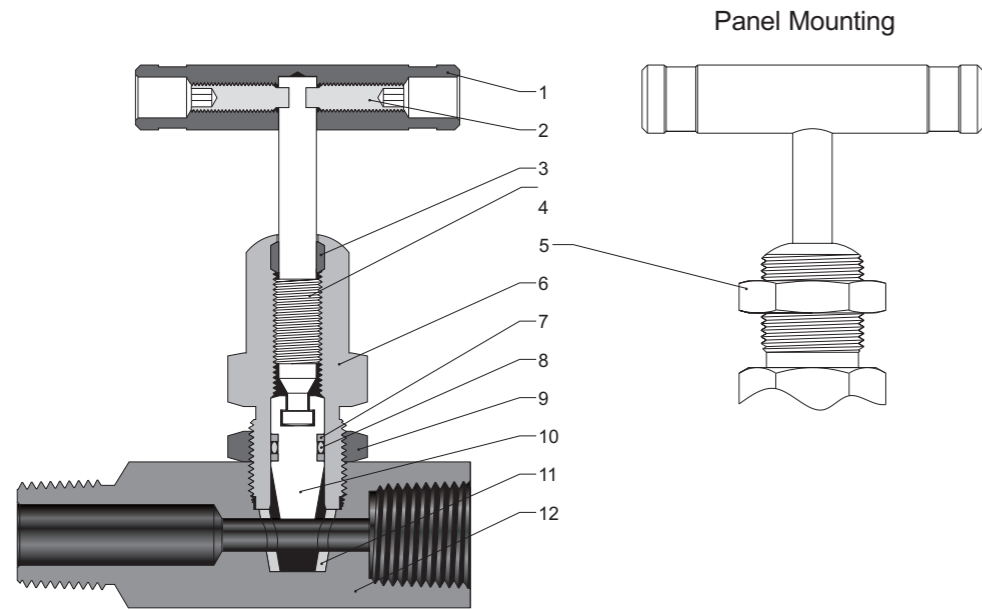

Item	Component	Valve Body Material			
		316 SS	304 SS	321 SS	Alloy R-405
1	Handle	Stainless steel or anodized aluminum or black knob			
2	Set Screw	Nickel cadmium-plated steel			
3	Wiper Ring	PTFE/D1710			
4	Upper Stem	316 SS/A276	304 SS/A276	321 SS/A276	Alloy R-405/B164
5	Panel Nut	316 SS/B783			
6	Bonnet	316 SS/A479	304 SS/A479	321 SS/A479	Alloy R-405/B164
7	Backup Ring	PTFE/D1710			
8	O-ring	Fluorocarbon FKM			
9	Lock Nut	316 SS/B783			
10	Stem Tip	316 SS/A276	304 SS/A276	321 SS/A276	Alloy R-405/B164
11	Seat	Acetal or PEEK or PFA			
12	Body	316 SS/A479	304 SS/A479	321 SS/A479	Alloy R-405/B164
Lubricant		Molybdenum disulfide-based and fluorocarbon-based			

#### Sour Gas Application

NR series valves are available for sour gas application. Materials for wetted components are in accordance with NACE specification MR0175 for sulfide stress cracking-resistant materials.

#### Materials

Body, bonnet: annealed 316 SS  
 O-ring: ethylene propylene  
 Stem tip: alloy R-405/ASTM B164  
 All other components are the same as standard product.

### Dimensions

Standard Pattern  
63N Series

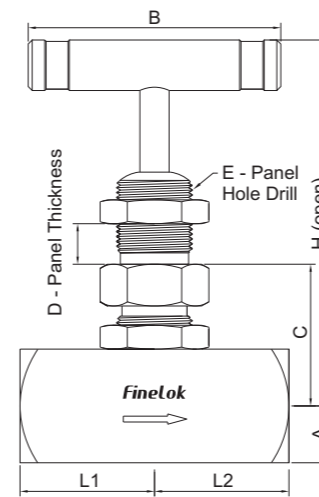

Gauge Port Pattern  
63GN Series

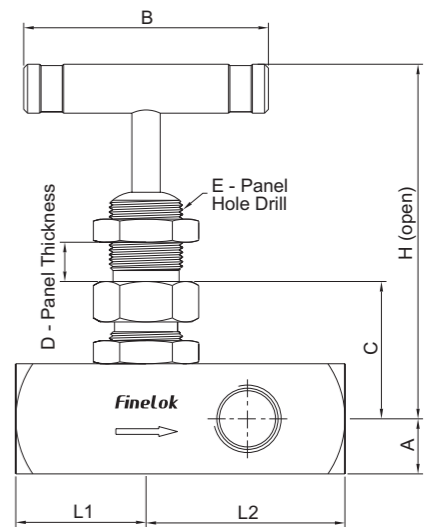

Basic Ordering Number	Connection Type and Size		Orifice in.(mm)	Cv	Dimension, in.(mm)									
	Inlet	Outlet			L1	L2	A	B	C	D	E	H		
-63N-FNT4-4	1/4 Female NPT	1/4 Female NPT	0.187 (4.8)	0.63	1.12 (28.4)									
-63N-NT4-FNT4-4	1/4 Male NPT	1/4 Female NPT			1.78 (45.2)	1.12 (28.4)	0.44 (11.1)							
-63N-NT8-FNT4-4	1/2 Male NPT	1/4 Female NPT			1.89 (48.0)			2.17 (55)	1.08 (27.5)	0.25 (6.4)	0.65 (16.1)	3.77 (95.8)		
-63GN-FNT4-4	1/4 Female NPT	1/4 Female NPT			1.12 (28.4)	1.75 (44.4)	0.50 (12.7)							
-63GN-NT8-FNT4-4	1/2 Male NPT	1/4 Female NPT												
-63N-FNT8-6	1/2 Female NPT	1/2 Female NPT			0.25 (6.4)	1.80	1.33 (33.8)							
-63N-NT8-FNT8-6	1/2 Male NPT	1/2 Female NPT	2.16 (54.9)	1.33 (33.8)										
-63N-63N-NT12-FNT8-6	3/4 Male NPT	1/2 Female NPT					0.56 (14.3)	2.5 (63.5)	1.4 (35.5)	0.38 (9.7)	0.77 (19.6)	3.83 (97.3)		
-63GN-FNT8-6	1/2 Female NPT	1/2 Female NPT	3.33 (84.6)	2.25 (57.2)										
-63GN-NT12-FNT8-6	3/4 Male NPT	1/2 Female NPT												

- Sizes and types listed are standard. Other sizes and types are available upon request.
- For dimensions not shown above, please contact the authorized representative or FINELOK.

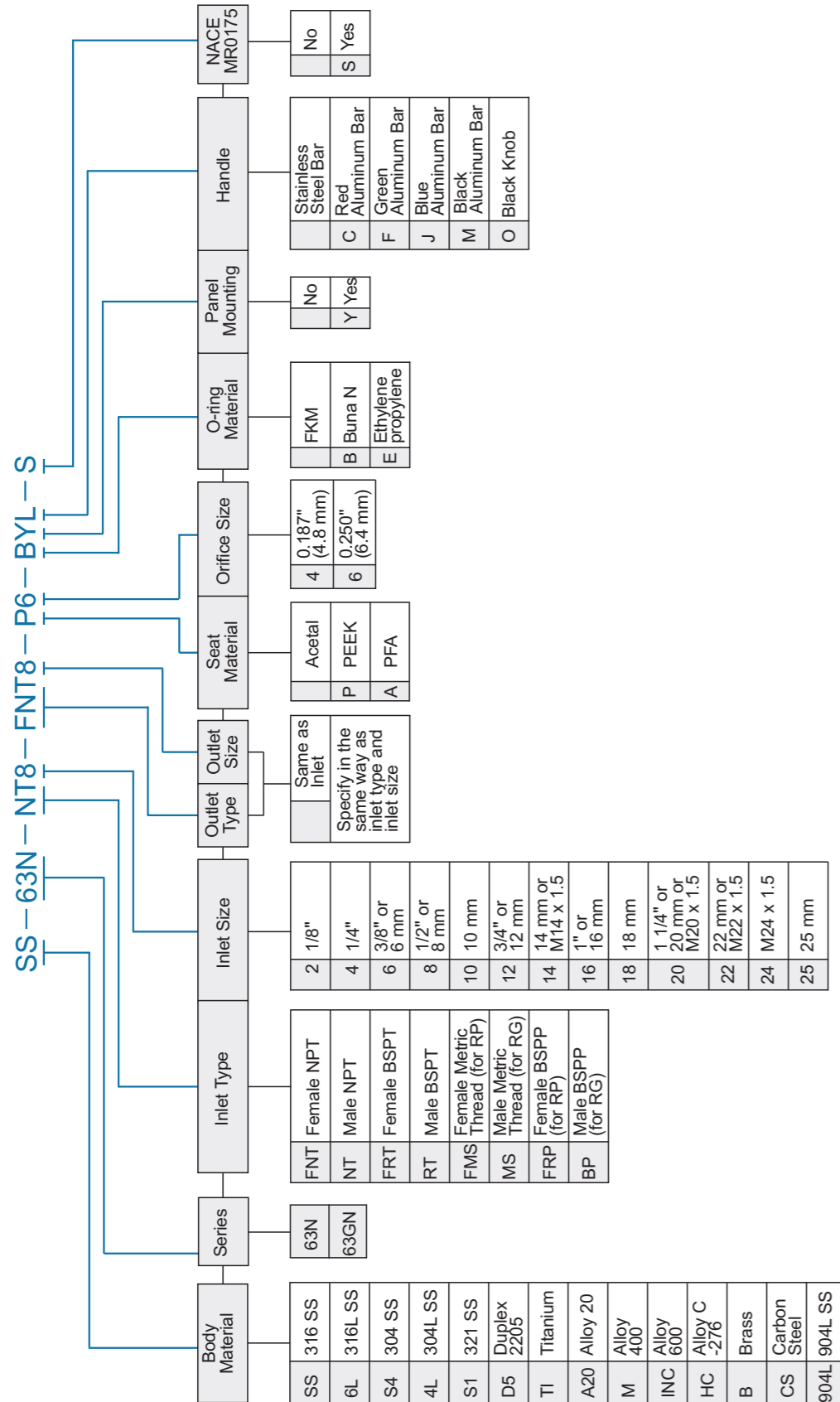

# High-pressure Needle Valves

## 100N Series

Maximum working pressure: 10000 psig (689 bar)

Working temperature:

PTFE: -65°F to 450°F (-54°C to 232°C)

PEEK: -65°F to 500°F (-54°C to 260°C)

Graphite: -65°F to 1200°F (-54°C to 649°C)



### Features

- ☆ One-piece body construction
- ☆ Two-stem design: thread hardened upper stem and smooth surface hardened lower stem
- ☆ Upper stem thread lubricant isolated from system media
- ☆ Linearly instead of helical movement of the nonrotating lower stem, avoiding galling damage to the seat and tip, as well as reducing the total friction area between the packing and the lower stem
- ☆ Safety back seating seal in fully open position
- ☆ Panel mounting available as an option
- ☆ Steady and durable fastening of the handle by double lock-pins
- ☆ Handle of different colors available for option
- ☆ Leak-tight performance testing for every valve with nitrogen at 6000 psig

### Pressure vs. Temperature

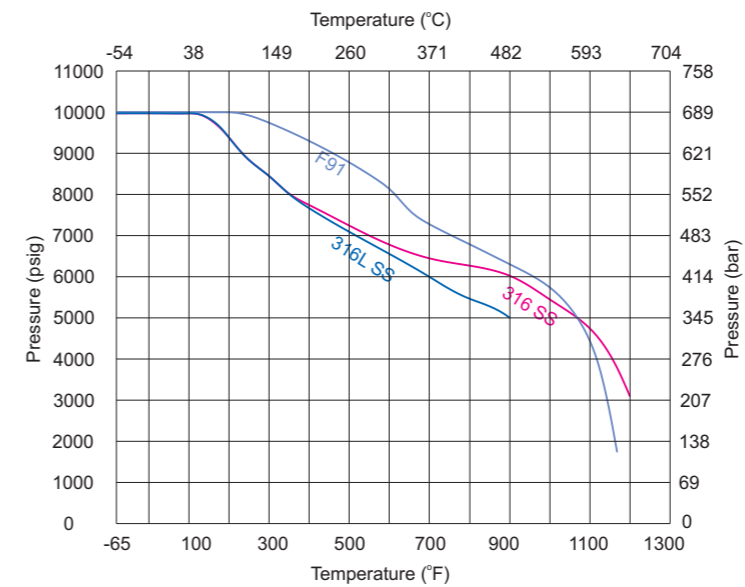

### Flow Data at 100°F (38°C)

Regulating Stem

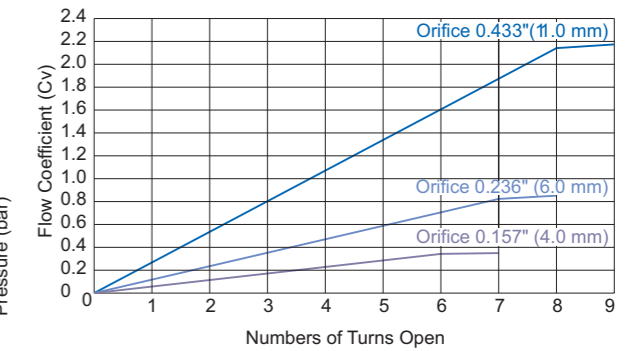

1. Graphs are based on graphite stem packing.
2. Contact the authorized representative or FINELOK for curve graph of other materials.



### Standard Materials of Construction

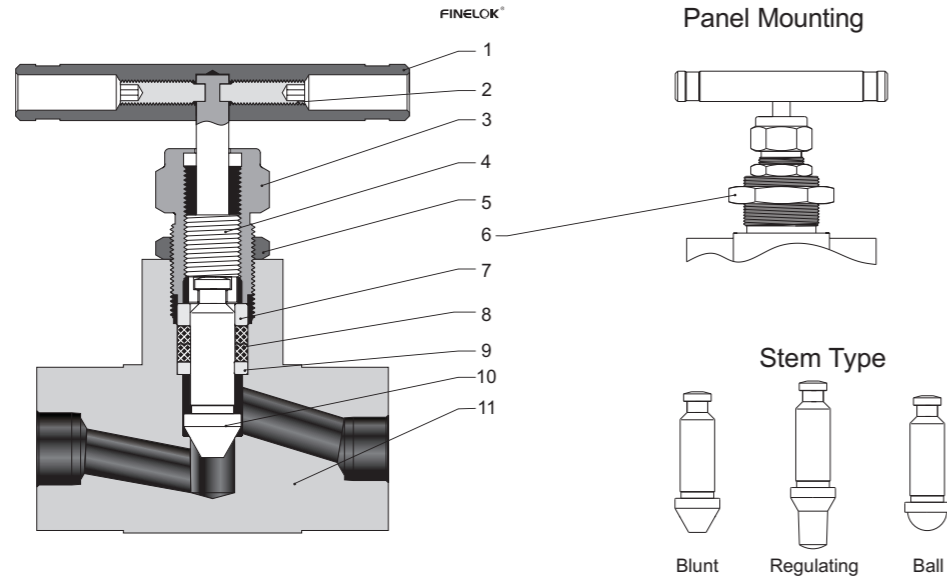

Item	Component	Valve Body Material			
		316L SS	316 SS	F91	F92
1	Handle	Anodized aluminum or stainless steel or black knob			
2	Set Screw	Nickel cadmium-plated steel			
3	Packing Bolt	321 SS/A276			
4	Upper Stem	321 SS/A276			
5	Lock Nut	316 SS/B783			
6	Panel Nut	316 SS/B783			
7	Gland	316 SS/A276	316 SS/A276	F91/A182	F92/A182
8	Packing	PTFE or PEEK or graphite			
9	Packing Washer	316 SS/A276	316 SS/A276	F91/A182	F92/A182
10	Lower Stem	Chrome-plated 316 SS/A276	Chrome-plated 316 SS/A276	Chrome-plated F91/A182	Chrome-plated F92/A182
		Optional			
11	Body	316L SS/A479 316L SS/A182	316 SS/A479 316 SS/A182	F91/A182	F92/A182
	Seat	Weld stellite seat optional			
	Lubricant	Molybdenum disulfide-based			

### Dimensions

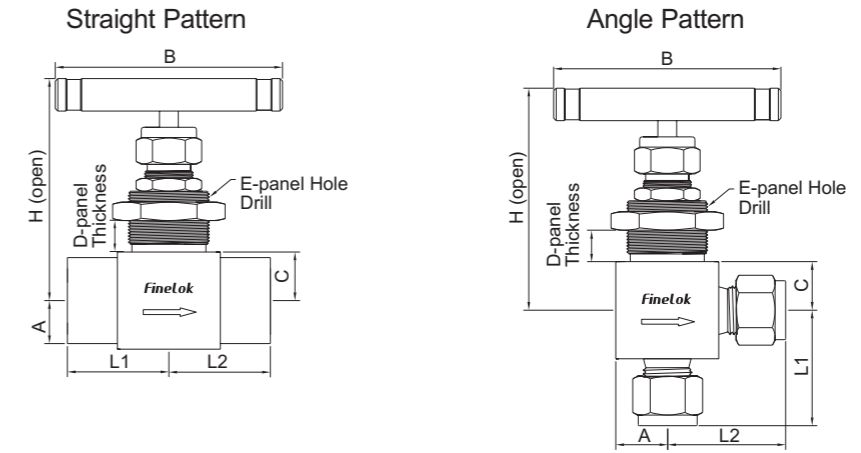

Basic Ordering Number	Connection Type and Size		Orifice in.(mm)	Cv	Dimension, in.(mm)																	
	Inlet	Outlet			L1	L2	A	B	C	D	E	H										
-100N-FNT2-4	1/8 Female NPT	1/8 Female NPT	0.157 (4.0)	0.35	1.13 (28.6)	1.13 (28.6)	0.53 (13.5)	2.17 (55)	0.53 (13.5)	0.25 (6.4)	0.96 (24.4)	2.85 (72.5)										
-100N-FNT4-4	1/4 Female NPT	1/4 Female NPT																				
-100N-FNT4-NT4-4	1/4 Female NPT	1/4 Male NPT																				
-100N-NT4-4	1/4 Male NPT	1/4 Male NPT																				
-100N-S4-4	1/4" FINELOK	1/4" FINELOK																				
-100N-SM6-4	6 mm FINELOK	6 mm FINELOK																				
-100N-SM8-4	8 mm FINELOK	8 mm FINELOK																				
-100N-FS4-4	1/4" FS	1/4" FS																				
-100N-FNT4-6	1/4 Female NPT	1/4 Female NPT											0.236 (6.0)	0.85	1.31 (33.4)	1.31 (33.4)	0.625 (15.88)	2.50 (63.5)	0.625 (15.88)	0.38 (9.7)	1.09 (27.7)	3.5 (88.9)
-100N-FNT6-6	3/8 Female NPT	3/8 Female NPT																				
-100N-FNT8-6	1/2 Female NPT	1/2 Female NPT																				
-100N-S6-6	3/8" FINELOK	3/8" FINELOK																				
-100N-S8-6	1/2" FINELOK	1/2" FINELOK																				
-100N-SM10-6	10 mm FINELOK	10 mm FINELOK																				
-100N-SM12-6	12 mm FINELOK	12 mm FINELOK																				
-100N-SM14-6	14 mm FINELOK	14 mm FINELOK																				
-100N-FS6-6	3/8" FS	3/8" FS																				
-100N-FS8-6	1/2" FS	1/2" FS																				
-100N-MW12-6	12 mm MW	12 mm MW	0.433 (11.0)	2.18	1.56 (39.6)	1.56 (39.6)	0.875 (22.2)	3.5 (88.9)	0.875 (22.2)	0.38 (9.7)	1.28 (32.5)	4.17 (106)										
-100N-MW14-6	14 mm MW	14 mm MW																				
-100N-FNT8-11	1/2 Female NPT	1/2 Female NPT																				
-100N-FNT12-11	3/4 Female NPT	3/4 Female NPT																				
-100N-S12-11	3/4" FINELOK	3/4" FINELOK																				
-100N-SM14-11	14 mm FINELOK	14 mm FINELOK																				
-100N-SM16-11	16 mm FINELOK	16 mm FINELOK																				
-100N-SM18-11	18 mm FINELOK	18 mm FINELOK																				
-100N-MW14-11	14 mm MW	14 mm MW																				
-100N-MW16-11	16 mm MW	16 mm MW																				
-100N-MW16-MW14-11	16 mm MW	14 mm MW																				

1. FINELOK means FINELOK double ferrule tube fittings, FS means fractional tube socket weld, MW means metric tube socket weld.
2. Sizes and types listed are standard. Other sizes and types are available upon request, refer to the nitrogen information.
3. Dimensions are shown with FINELOK nuts finger-tightened. All dimensions are for reference only and are subject to change. For dimensions not shown above, please contact the authorized representative or FINELOK.

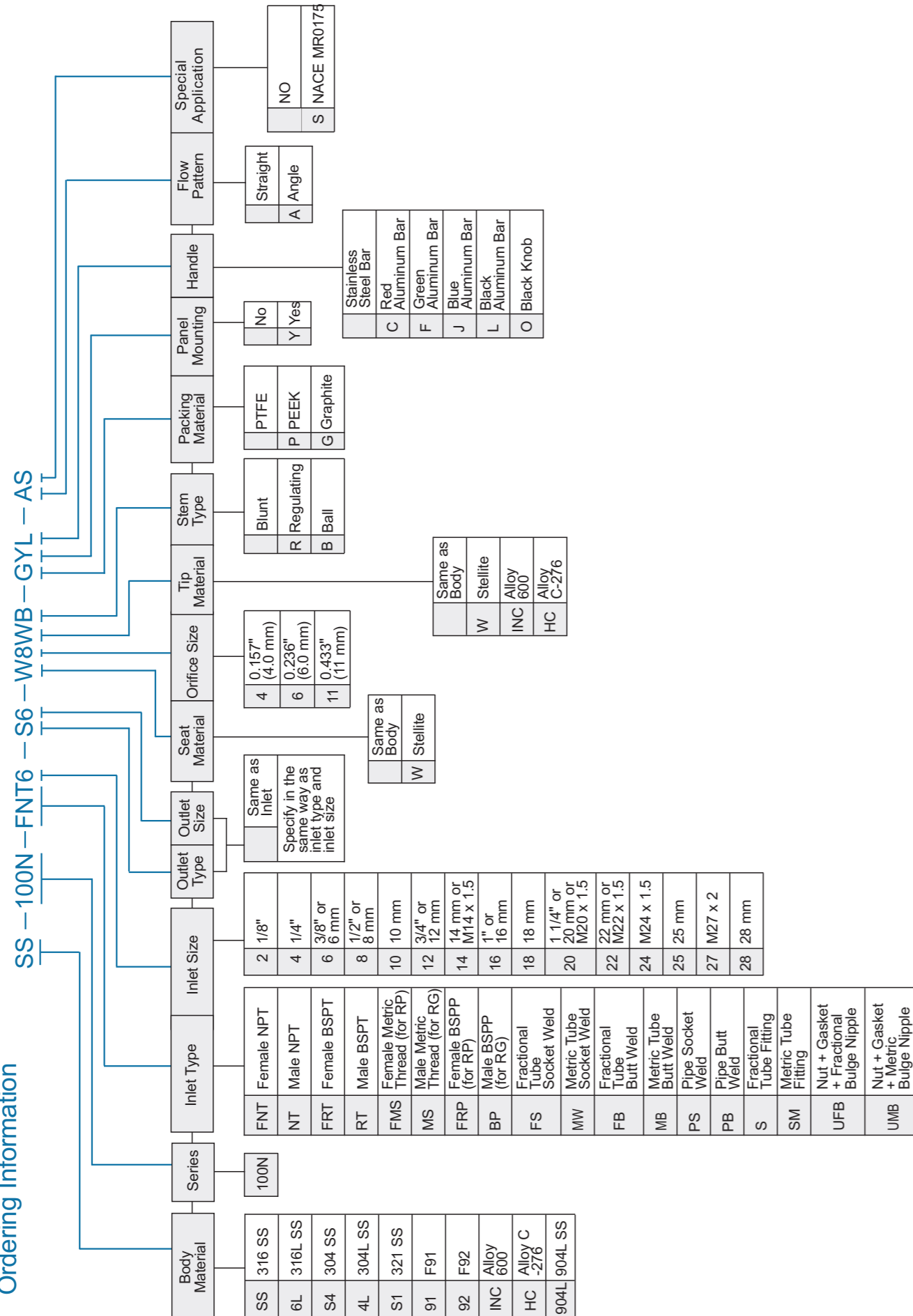

# Outside Screw and Yoke Globe Pattern Needle Valves

## 101N Series

Maximum working pressure: 10000 psig (689 bar)

Working temperature:

PTFE: -65°F to 450°F (-54°C to 232°C)

PEEK: -65°F to 500°F (-54°C to 260°C)

Graphite: -65°F to 1200°F (-54°C to 649°C)

Standard seat diameter 4mm (0.16"). Cv: 0.35 standard



### Features

- ☆ Hardened stem threads prevent galling
- ☆ Stem threads completely isolated from system media
- ☆ The nonrotating stem provides repetitive shutdf
- ☆ Back seat construction provides secondary stem sealing and prevents stem blowout
- ☆ Externally adjustable gland, independent of spindle thread
- ☆ Self centering non rotating spindle tip for bubble tight shut df
- ☆ Steady and durable fastening of the handle by double lock-pins
- ☆ Base mount option
- ☆ Leak-tight performance testing for every valve with nitrogen at 6000 psig

### Pressure vs. Temperature

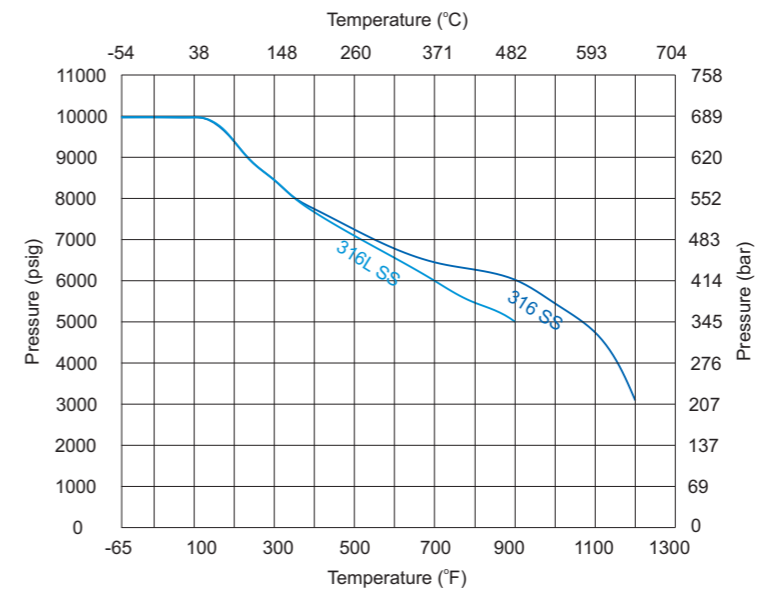

1. Graphs are based on graphite stem packing.
2. Contact the authorized representative or FINELOK for curve graph of other materials.

### Standard Materials of Construction

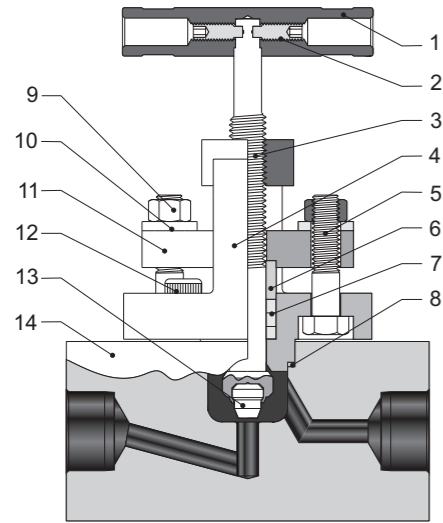

Item	Component	Valve Body Material
		316 SS
1	Handle	Stainless steel
2	Set Screw	Nickel cadmium-plated steel
3	Stem	Chrome-plated 316 SS/A276
4	Yoke	316 SS/A182
5	Bolt	Stainless steel
6	Packing Gland	316 SS/A276
7	Packing	PTFE or PEEK or graphite
8	Joint Seal	PTFE or graphite
9	Nut	Stainless steel
10	Gasket	Stainless steel
11	Gland Bridge	316 SS/A182
12	Bolt	Stainless steel
13	Stem Tip	316 SS/A276
14	Body	316 SS/A479
Lubricant		Molybdenum disulfide-based

### Dimensions

Basic Ordering Number	Connection Type and Size		Orifice in.(mm)	Cv	Dimension, in.(mm)		
	Inlet	Outlet			L	A	H
-101N-FNT4	1/4 Female NPT	1/4 Female NPT	0.157 (4.0)	0.35	2.685 (68.2)	1.50 (38.1)	3.894 (98.9)
-101N-NT4	1/4 Male NPT	1/4 Male NPT			2.953 (75.0)		
-101N-NT4-FNT4	1/4 Male NPT	1/4 Female NPT			2.724 (69.2)		
-101N-FNT6	3/8 Female NPT	3/8 Female NPT			2.953 (75.0)		
-101N-NT6	3/8 Male NPT	3/8 Male NPT			3.00 (76.2)		
-101N-FNT8	1/2 Female NPT	1/2 Female NPT			3.268 (82.0)		
-101N-NT8	1/2 Male NPT	1/2 Male NPT			3.00 (76.2)		
-101N-NT8-FNT8	1/2 Male NPT	1/2 Female NPT			3.00 (76.2)		
-101N-SW8	1/2 PS	1/2 PS			3.535 (89.8)		
-101N-BW8	1/2 PB	1/2 PB			3.441 (87.4)		
-101N-S4	1/4" FINELOK	1/4" FINELOK			3.50 (88.9)		
-101N-S6	3/8" FINELOK	3/8" FINELOK			3.78 (96.0)		
-101N-S8	1/2" FINELOK	1/2" FINELOK			3.441 (87.4)		
-101N-SM6	6 mm FINELOK	6 mm FINELOK			3.78 (96.0)		
-101N-SM8	8 mm FINELOK	8 mm FINELOK					
-101N-SM12	12 mm FINELOK	12 mm FINELOK					

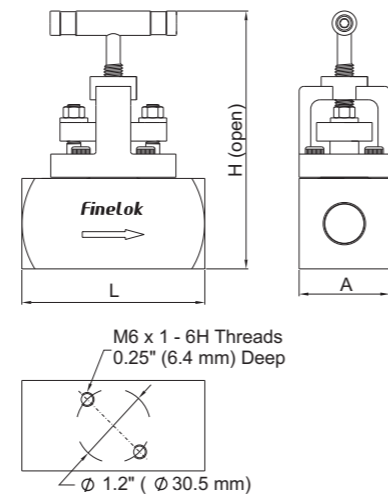

1. FINELOK means FINELOK double ferrule tube fittings.
2. Sizes and types listed are standard. Other sizes and types are available upon request, refer to the ordering information.
3. Dimensions are shown with FINELOK nuts finger-tightened. All dimensions are for reference only and are subject to change. For dimensions not shown above, please contact the authorized representative or FINELOK.

### Ordering Information

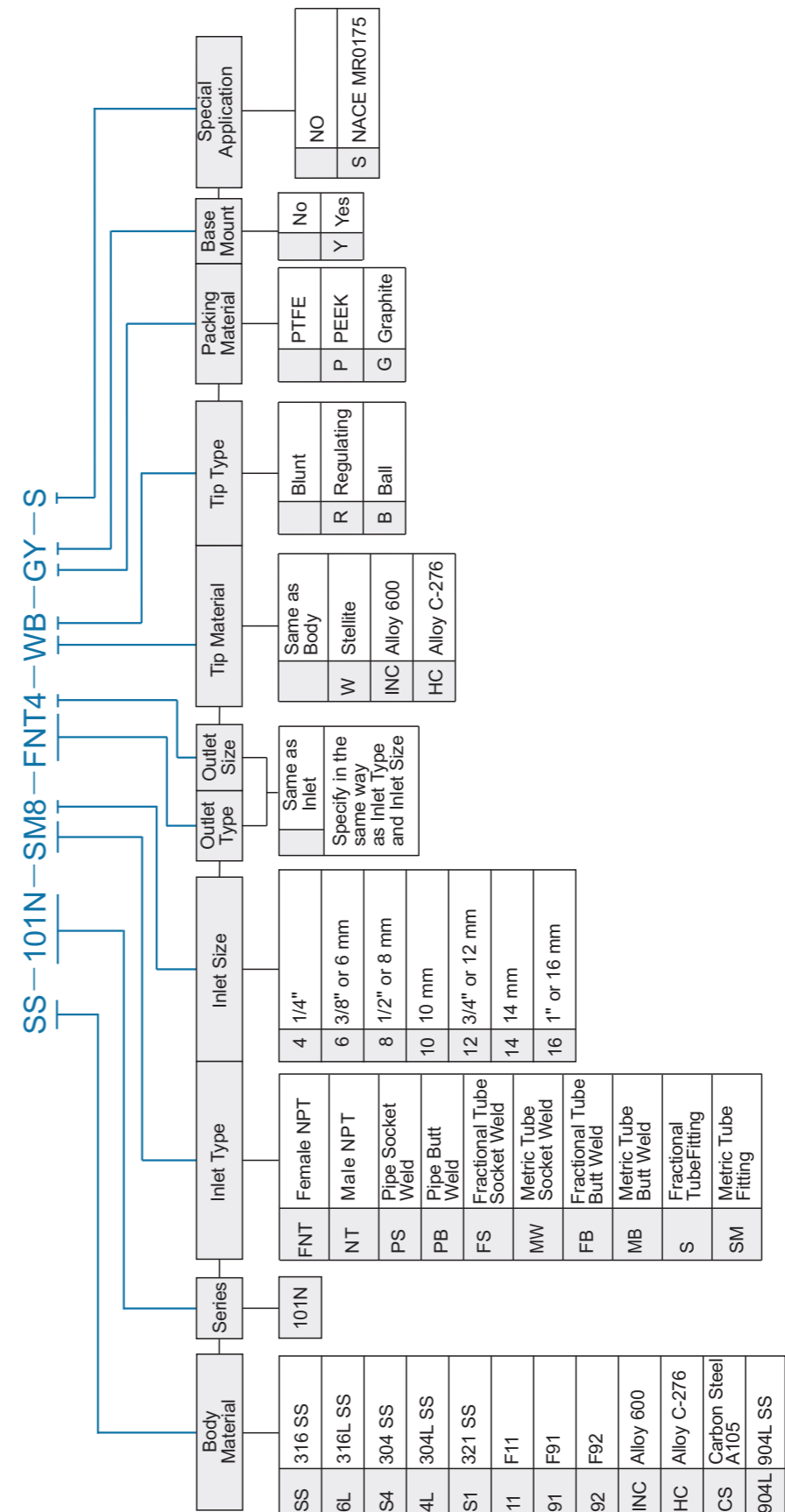

# Integral-Bonnet Needle Valves

## 50N Series

- Maximum working pressure:
- Stainless steel: 5000 psig (345 bar)
  - Steel: 3000 psig (207 bar)
  - Brass: 3000 psig (207 bar)
- Working temperature:
- PTFE: -65°F to 450°F (-54°C to 232°C)
  - PEEK: -65°F to 600°F (-54°C to 315°C)



### Features

- ☆ Live-loaded packing system
- ☆ Compact design
- ☆ Rolled stem threads for longer valve life
- ☆ Easy external adjustments by packing nut
- ☆ Leak-tight performance testing for every valve with nitrogen at the maximum working pressure

### Pressure vs. Temperature

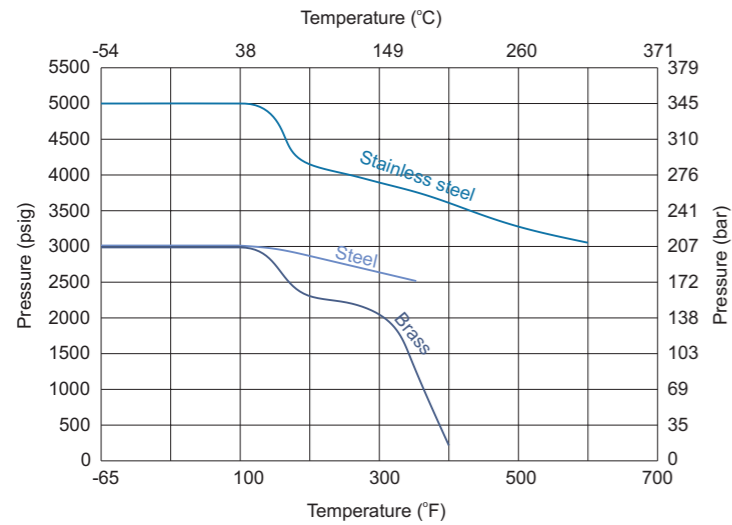

### Flow Data at 100°F (38°C)

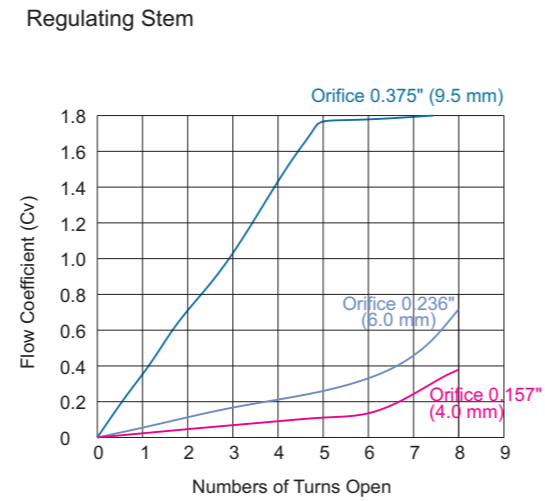

1. Graphs are based on PEEK stem packing.
2. 200°F (93°C) max with PCTFE stem tip (soft tip).
3. Contact the authorized representative or FINELOK for curve graph of other materials.

### Standard Materials of Construction

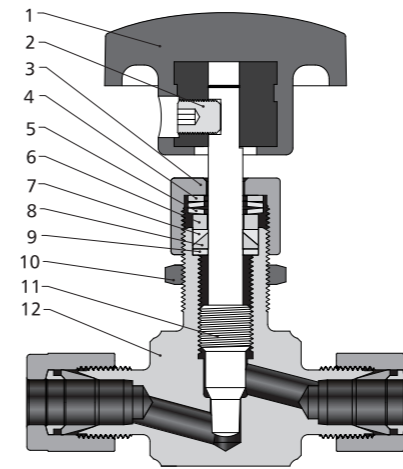

#### Stem Type

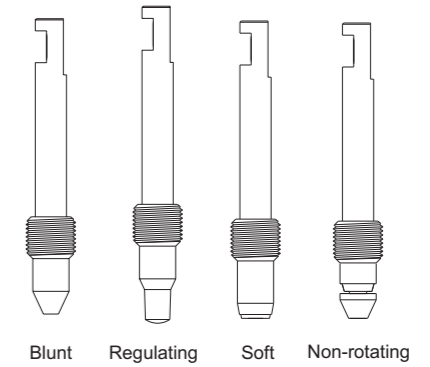

Item	Component	Valve Body Material		
		316 SS	Brass	Steel
1	Handle	Black knob or anodized aluminum or stainless steel		
2	Set Screw	Nickel cadmium-plated steel		
3	Packing Nut	316 SS/A276	Brass 360/B16	12L14/A108
4	Gland	304 SS/A276		
5	Packing Spring	S17700/A693		
6	Packing Gland	304 SS/A276		
7	Upper Packing	PTFE or PEEK		
8	Lower Packing			
9	Lower Gland	316 SS/A276		
10	Panle Nut	316 SS/B783		
11	Stem	Chrome-plated 316 SS/A276		
12	Body	316 SS/A182	Brass 377/B283	Chrome-plated 11L17/A108
Lubricant		Molybdenum disulfide-based and silicone-based		



Dimensions

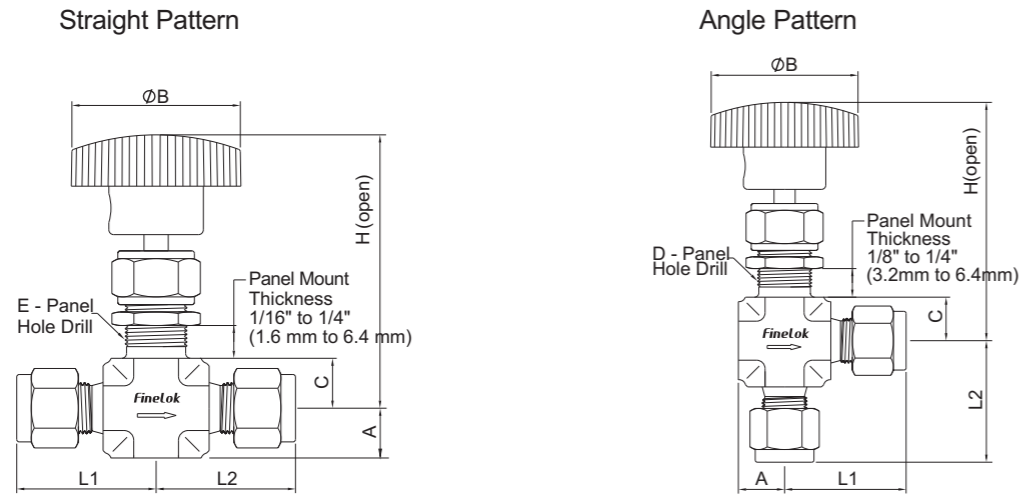

Basic Ordering Number	Connection Type and Size		Orifice in.(mm)	Cv	Dimension, in.(mm)													
	Inlet	Outlet			L1	L2	A	B	C	D	H							
-50N-FNT2-2	1/8 Female NPT	1/8 Female NPT	0.08 (2.0)	0.09	0.81 (20.6)	0.81 (20.6)	0.31 (7.9)	1.0 (25.4)	0.44 (11.2)	0.47 (11.9)	2.28 (57.9)							
-50N-S2-2	1/8" FINELOK	1/8" FINELOK			0.98 (25.0)	0.98 (25.0)												
-50N-SM3-2	3 mm FINELOK	3 mm FINELOK																
-50N-FNT2-4	1/8 Female NPT	1/8 Female NPT	0.157 (4.0)	0.35	0.81 (20.6)	0.81 (20.6)	0.41 (10.4)	1.38 (35.0)	0.44 (11.2)	0.53 (13.5)	2.50 (63.5)							
-50N-NT2-4	1/8 Male NPT	1/8 Male NPT			0.98 (25.0)	0.98 (25.0)												
-50N-NT4-4	1/4 Male NPT	1/4 Male NPT			1.13 (28.7)	1.13 (28.7)												
-50N-S4-4	1/4" FINELOK	1/4" FINELOK																
-50N-SM6-4	6 mm FINELOK	6 mm FINELOK																
-50N-SM8-4	8 mm FINELOK	8 mm FINELOK																
-50N-FNT4-6	1/4 Female NPT	1/4 Female NPT	0.25 (6.4)	0.70	1.06 (26.9)	1.06 (26.9)	0.5 (12.7)	1.88 (47.8)	0.5 (12.7)	0.78 (19.8)	2.97 (75.4)							
-50N-FNT6-6	3/8" Female NPT	3/8" Female NPT			1.12 (28.4)	1.12 (28.4)												
-50N-NT6-6	3/8 Male NPT	3/8 Male NPT			1.50 (38.1)	1.50 (38.1)												
-50N-NT8-6	1/2 Male NPT	1/2 Male NPT			1.29 (32.8)	1.29 (32.8)												
-50N-S6-6	3/8" FINELOK	3/8" FINELOK			1.4 (35.6)	1.4 (35.6)												
-50N-S8-6	1/2" FINELOK	1/2" FINELOK																
-50N-SM10-6	10 mm FINELOK	10 mm FINELOK																
-50N-SM12-6	12 mm FINELOK	12 mm FINELOK																
-50N-SM14-6	14 mm FINELOK	14 mm FINELOK																
-50N-MS20-6	M20 x 1.5 Male ISO	M20 x 1.5 Male ISO																
-50N-FNT8-10	1/2 Female NPT	1/2 Female NPT			0.375 (9.5)	1.80						1.50 (38.1)	1.50 (38.1)	0.75 (19.1)	3.00 (76.2)	0.75 (19.1)	1.03 (26.2)	3.91 (99.3)
-50N-FNT12-10	3/4 Female NPT	3/4 Female NPT										1.63 (41.3)	1.63 (41.3)					
-50N-NT12-10	3/4 Male NPT	3/4 Male NPT																
-50N-S8-10	1/2" FINELOK	1/2" FINELOK																
-50N-S12-10	3/4" FINELOK	3/4" FINELOK																
-50N-SM14-10	14 mm FINELOK	14 mm FINELOK																

1. FINELOK means FINELOK double ferrule tube fittings, ISO means metric thread,
2. Sizes and types listed are standard. Other sizes and types are available upon request, refer to the ordering information.
3. Dimensions are shown with FINELOK nuts finger-tightened. All dimensions are for reference only and are subject to change. For dimensions not shown above, please contact the authorized representative or FINELOK.

Ordering Information

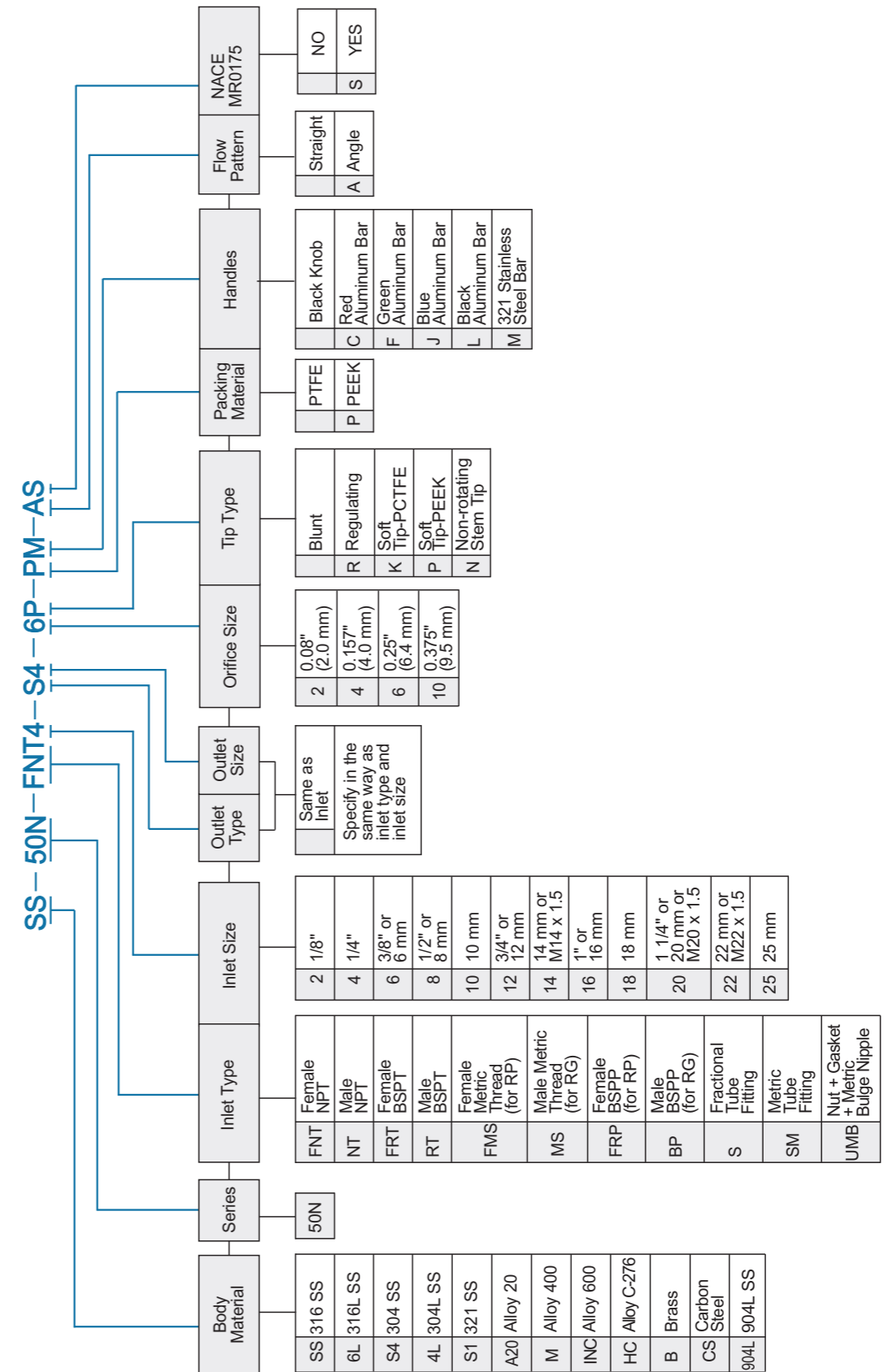

# Nonrotating-stem Needle Valves

## 30N Series

Maximum working pressure: 3000 psig (207 bar)

Working temperature:

PCTFE stem tip: -20°F to 200°F (-28°C to 93°C)

PEEK stem tip: -20°F to 450°F (-28°C to 232°C)



### Features

- ☆ Straight and angle pattern
- ☆ Compact design
- ☆ Nonrotating stem
- ☆ Special designed handle to stop contamination entering into the valve
- ☆ Leak-tight performance testing for every valve with nitrogen at the maximum working pressure

### Pressure vs. Temperature

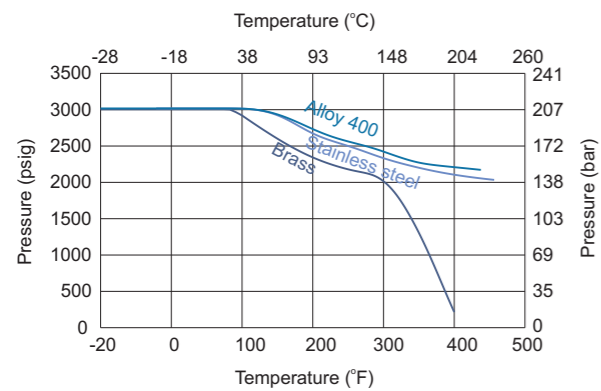

### Flow Data at 100°F (38°C)

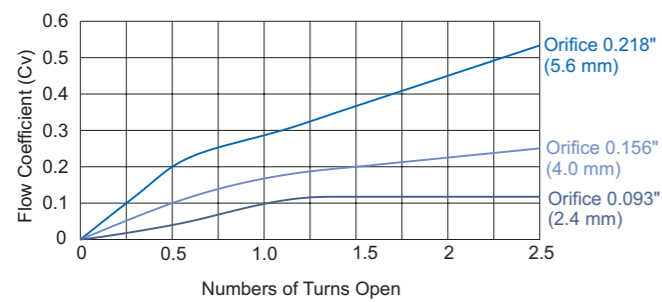

1. Temperature and pressure shown in the graphs are based on PEEK stem tip
2. Contact the authorized representative or FINELOK for curve graph of other materials.

### Standard Materials of Construction

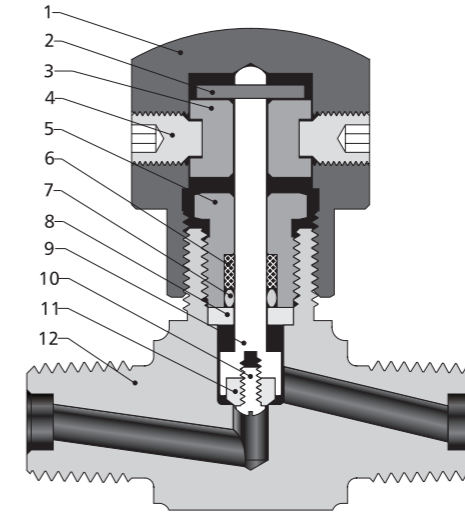

Item	Component	Valve Body Material				
		316 SS	304 SS	321 SS	Brass	Alloy 400
1	Handle	Anodized aluminum				
2	Stop Pin	Stainless steel				
3	Spool	Aluminum				
4	Set Screw	Nickel cadmium-plated steel				
5	Packing Bolt	316 SS/A276	304 SS/A276	321 SS/A276	Brass 360/B16	Alloy R-405/B164
6	Backup Ring	PTFE/D1710				
7	O-ring	Fluorocarbon FKM				
8	Washer	316 SS/A276				Alloy R-405/B164
9	Stem	316 SS/A276				Alloy R-405/B164
10	Machine Screw	316 SS/A276				Alloy R-405/B164
11	Stem Tip	PCTFE or PEEK				
12	Body	316 SS/A182	316 SS/A182	316 SS/A182	Brass 377/B283	Alloy 400/B564
Lubricant		Molybdenum disulfide-based				

Dimensions

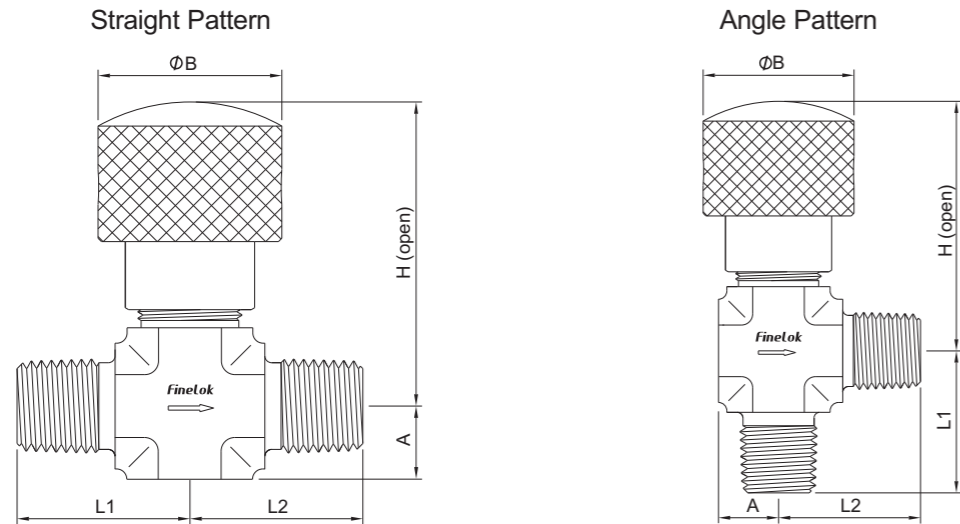

Basic Ordering Number	Connection Type and Size		Orifice in.(mm)	Cv	Dimension, in.(mm)				
	Inlet	Outlet			L1	L2	A	B	H
-30N-NT2-2	1/8 Male NPT	1/8 Male NPT	0.09 (2.4)	0.12	0.75 (19.0)	0.75 (19.0)	0.31 (7.9)	1.06 (26.9)	1.86 (47.2)
-30N-NT2-S2-2	1/8" Male NPT	1/8" FINELOK			0.75 (19.0)	1.1 (27.9)			
-30N-S2-2	1/8" FINELOK	1/8" FINELOK			1.1 (27.9)	1.1 (27.9)			
-30N-SM3-2	3 mm FINELOK	3 mm FINELOK	0.156 (4.0)	0.27	0.81 (20.6)	0.81 (20.6)	0.39 (9.9)	1.06 (26.9)	1.86 (47.2)
-30N-FNT2-4	1/8 Female NPT	1/8 Female NPT			0.86 (21.8)	0.86 (21.8)			
-30N-NT2-4	1/8 Male NPT	1/8 Male NPT			25.0 (0.98)	25.0 (0.98)			
-30N-NT4-4	1/4 Male NPT	1/4 Male NPT			25.0 (0.98)	25.0 (0.98)			
-30N-NT4-S4-4	1/4" Male NPT	1/4" FINELOK			1.13 (28.7)	1.13 (28.7)			
-30N-S4-4	1/4" FINELOK	1/4" FINELOK							
-30N-SM6-4	6 mm FINELOK	6 mm FINELOK							
-30N-SM8-4	8 mm FINELOK	8 mm FINELOK							
-30N-FNT4-6	1/4 Female NPT	1/4 Female NPT			0.218 (5.6)	0.53			
-30N-FNT6-6	3/8 Female NPT	3/8 Female NPT	1.12 (28.6)	1.12 (28.6)					
-30N-NT6-6	3/8 Male NPT	3/8 Male NPT	1.29 (32.8)	1.29 (32.8)					
-30N-S6-6	3/8" FINELOK	3/8" FINELOK	1.4 (35.6)	1.4 (35.6)					
-30N-S8-6	1/2" FINELOK	1/2" FINELOK	1.3 (33.0)	1.3 (33.0)					
-30N-SM10-6	10 mm FINELOK	10 mm FINELOK	1.4 (35.6)	1.4 (35.6)					
-30N-SM12-6	12 mm FINELOK	12 mm FINELOK							
-30N-MS20-6	M20 x 1.5 Male ISO	M20 x 1.5 Male ISO	1.50 (38.1)	1.50 (38.1)					
-30N-MS22-6	M22 x 1.5 Male ISO	M22 x 1.5 Male ISO							

1. FINELOK means FINELOK double ferrule tube fittings, ISO means metric thread.
2. Sizes and types listed are standard. Other sizes and types are available upon request, refer to the ordering information.
3. Dimensions are shown with FINELOK nuts finger-tightened. All dimensions are for reference only and are subject to change. For dimensions not shown above, please contact the authorized representative or FINELOK.

Ordering Information

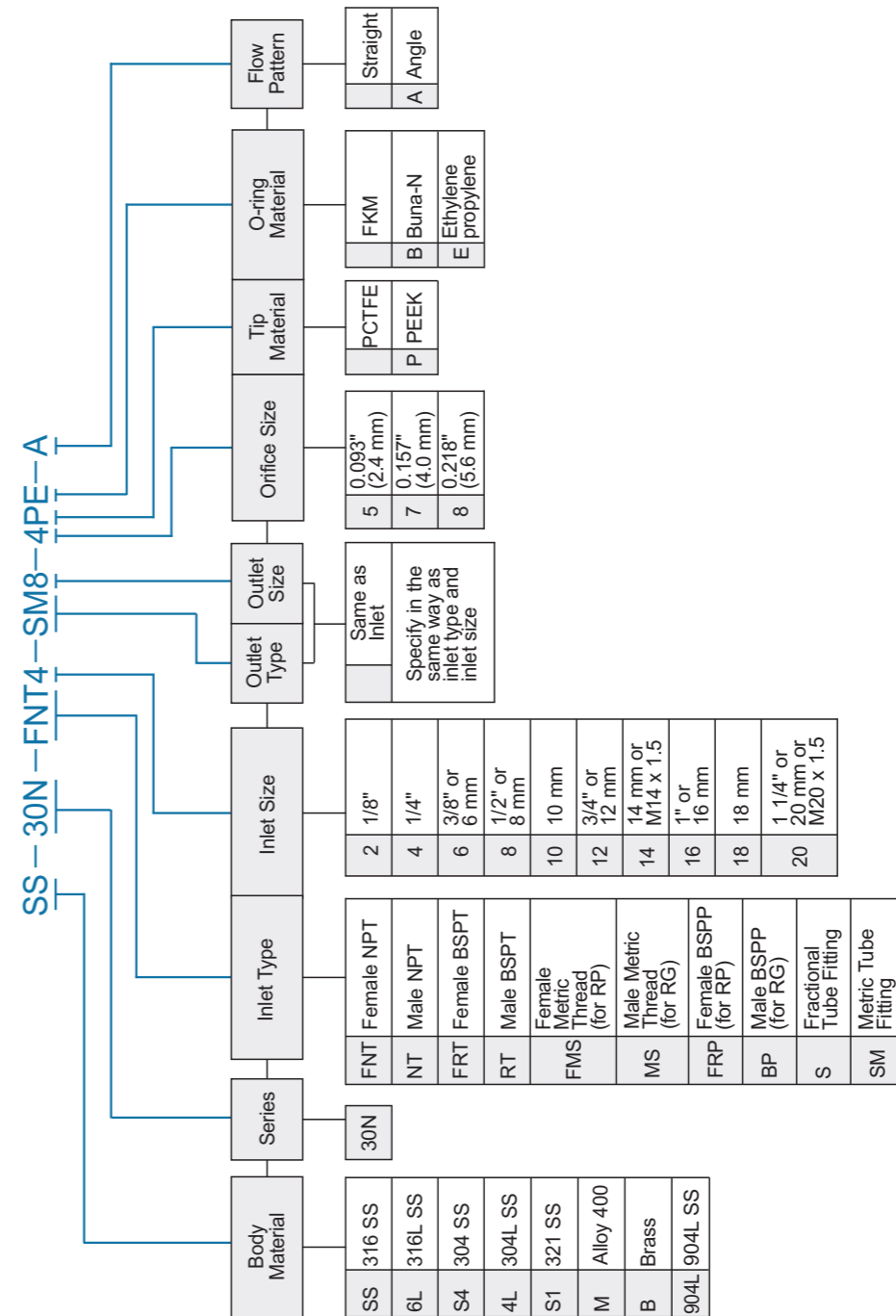

# Toggle Valves

## 03N Series

### Features

- ☆ Maximum working pressure: 300 psig (20.7 bar)
- ☆ Straight and angle pattern
- ☆ Compact design
- ☆ Quick opening or closing
- ☆ Nonrotating stem tip
- ☆ Leak-tight performance testing for every valve with nitrogen at the maximum working pressure



### Technical Data

Orifice	Working Pressure at 100°F (38°C)
2.0 mm	300 psig
3.2 mm	
6.4 mm	200 psig

O-ring Material	Temperature Rating
FKM(Standard)	-20°F to 200°F (-28°C to 93°C)
Buna N	-20°F to 250°F (-28°C to 121°C)
Buna C	-65°F to 250°F (-54°C to 121°C)
Ethylene Propylene	-20°F to 250°F (-28°C to 121°C)

### Standard Materials of Construction

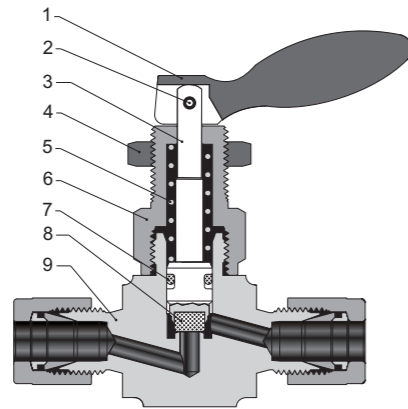

Item	Component	Valve Body Material			
		316 SS	304 SS	321 SS	Brass
1	Handle	Stainless steel			
2	Pin	Stainless steel			
3	Stem	316 SS/A276	304 SS/A276		
4	Panel Nut	316 SS/B783			Brass 360/B16
5	Spring	PTFE-plated S17700/A313			
6	Bonnet	316 SS/A276	304 SS/A276	321 SS/A276	Brass 360/B16
7	O-ring	Fluorocarbon FKM			
8	Stem Tip	PTFE/D1710			
9	Body	316 SS/A182	304 SS/A182	321 SS/A182	Brass 377/B283
Lubricant		Molybdenum disulfide-based and silicone-based			

### Dimensions

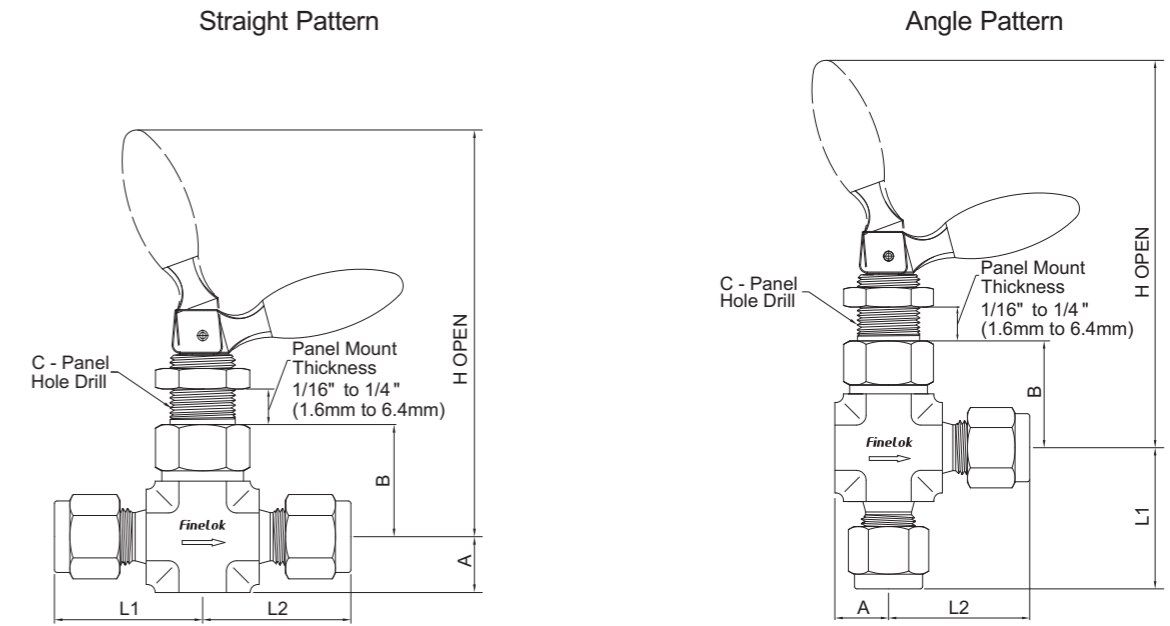

Basic Ordering Number	Connection Type and Size		Orifice in.(mm)	Cv	Dimension, in.(mm)					
	Inlet	Outlet			L1	L2	A	B	C	H
-03N-NT2-2	1/8 Male NPT	1/8 Male NPT	0.08 (2.0)	0.11	0.75 (19.0)	0.75 (19.0)	0.31 (7.9)	0.92 (23.4)	0.53 (13.5)	2.87 (72.9)
-03N-NT2-S2-2	1/8 Male NPT	1/8" FINELOK			0.75 (19.0)	0.98 (25.0)				
-03N-S2-2	1/8" FINELOK	1/8" FINELOK			0.98 (25.0)	0.98 (25.0)				
-03N-SM3-2	3 mm FINELOK	3 mm FINELOK								
-03N-FNT2-3	1/8 Female NPT	1/8 Female NPT	0.125 (3.2)	0.20	0.81 (20.6)	0.81 (20.6)	0.39 (9.9)	0.92 (23.4)	0.53 (13.5)	2.87 (72.9)
-03N-NT2-3	1/8 Male NPT	1/8 Male NPT			0.86 (21.8)	0.86 (21.8)				
-03N-NT4-3	1/4 Male NPT	1/4 Male NPT			25.0 (0.98)	25.0 (0.98)				
-03N-NT4-S4-3	1/4 Male NPT	1/4" FINELOK			25.0 (0.98)	1.13 (28.7)				
-03N-S4-3	1/4" FINELOK	1/4" FINELOK			1.13 (28.7)					
-03N-SM6-3	6 mm FINELOK	6 mm FINELOK								
-03N-SM8-3	8 mm FINELOK	8 mm FINELOK								
-03N-FNT4-6	1/4 Female NPT	1/4 Female NPT	0.25 (6.4)	0.70	1.06 (26.9)	1.06 (26.9)	0.5 (12.7)	1.06 (26.9)	0.66 (16.8)	3.56 (90.4)
-03N-FNT6-6	3/8 Female NPT	3/8 Female NPT			1.12 (28.4)	1.12 (28.4)				
-03N-NT6-6	3/8 Male NPT	3/8 Male NPT			1.29 (32.8)	1.29 (32.8)				
-03N-S6-6	3/8" FINELOK	3/8" FINELOK			1.4 (35.6)	1.4 (35.6)				
-03N-S8-6	1/2" FINELOK	1/2" FINELOK			1.36 (34.5)	1.36 (34.5)				
-03N-SM10-6	10 mm FINELOK	10 mm FINELOK			1.46 (37.1)	1.46 (37.1)				
-03N-SM12-6	12 mm FINELOK	12 mm FINELOK			1.50 (38.1)	1.50 (38.1)				
-03N-MS20-6	M20 x 1.5 Male ISO	M20 x 1.5 Male ISO								
-03N-MS22-6	M22 x 1.5 Male ISO	M22 x 1.5 Male ISO								

1. FINELOK means FINELOK double ferrule tube fittings, ISO means metric thread,
2. Sizes and types listed are standard. Other sizes and types are available upon request, refer to the ordering information.
3. Dimensions are shown with FINELOK nuts finger-tightened. All dimensions are for reference only and are subject to change. For dimensions not shown above, please contact the authorized representative or FINELOK.



## Ordering Information

