

High Pressure Needle Valve

N15 Series, 15,000 psi (1034 bar)

N20 Series, 20,000 psi (1379 bar)

N30 Series, 30,000 psi (2068 bar)

N60 Series, 60,000 psi (4137 bar)



Contents

N15 Series

15,000 psi (1034 bar)

1

N20 Series

20,000 psi (1379 bar)

6

N30 Series

30,000 psi (2068 bar)

11

N60 Series

60,000 psi (4137 bar)

15

Ordering Information

19

N15 Series

15,000 psi (1034 bar)

Features

- ☆ Tubing sizes available for 1/4", 3/8", 1/2".
- ☆ Non-rotating stem and bar stock body design.
- ☆ Metal-to-metal seating achieves ideal shutoff, longer stem/seat service lifetime for abrasive flow, excellent corrosion resistance and greater durability for repeated on/off cycles.
- ☆ PTFE is the standard packing material, RPTFE glass and Graphite also available.
- ☆ The location of packing is under the thread of valve stem.
- ☆ The material of packing gland and stem sleeve have been selected to achieve reduced handle torque and extended thread cycle life.
- ☆ The material of body is 316 SS, The material of stem is 17-4PH SS.
- ☆ Options for Vee or Regulating stem tips.
- ☆ The locking device of packing gland is reliable.
- ☆ Five flow patterns are available.

Technical Data

Tube OD in.	Connection Type	Orifice in. (mm)	Cv	Pressure @ room temperature psig (bar)
1/4	15S4	0.188 (4.77)	0.65	15,000 (1034)
3/8	15S6	0.250 (6.35)	0.95	15,000 (1034)
1/2	15S8	0.375 (9.53)	1.90	15,000 (1034)

Notes:

- ☆ The value of Cv shown are for 2-way straight valve pattern. The value of Cv for 2-way angle pattern will be increase about 50% (Base on water).
- ☆ Extreme Temperatures
PTFE is the standard packing material for FINELOK Needle Valve; RPTFE glass, Graphite and Extend stuffing box valve with graphite also available.
Normal Needle valve with PTFE packing can be operated to 450°F(232°C).
Normal Needle valve with RPTFE glass packing can be operated to 600°F(316°C).
Normal Needle valve with Graphite packing can be operated to 800°F(427°C).

Flow Data at 100°F (38°C)

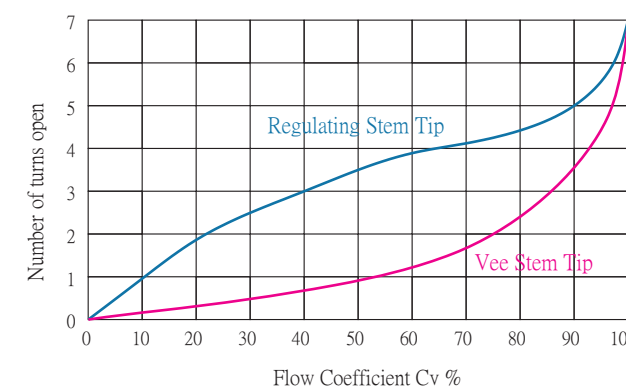

Pressure & Temperature

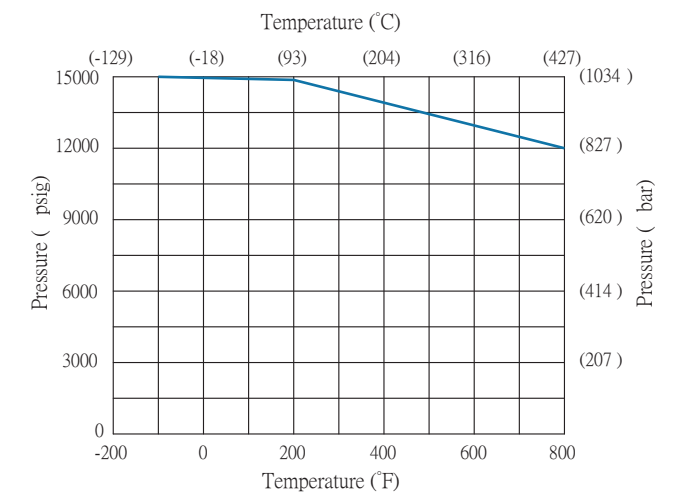

Standard Materials of Construction

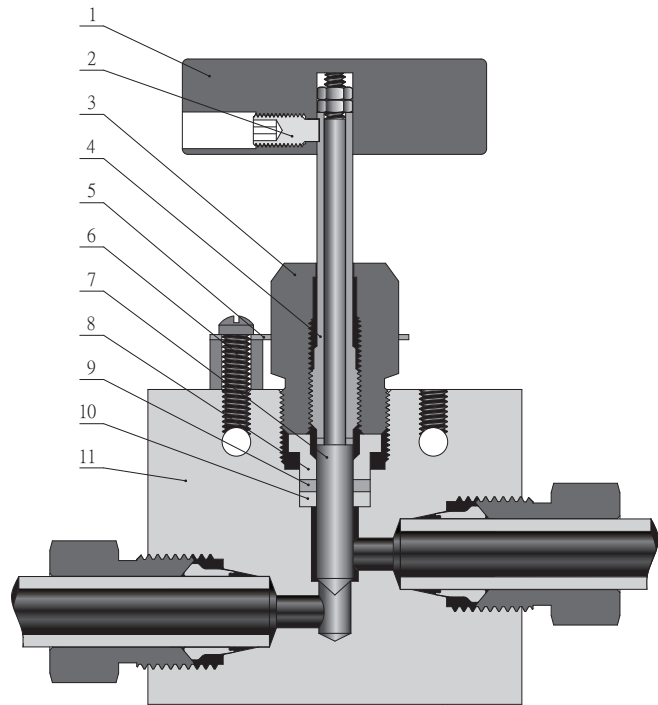

Item	Component	Material Grade/ASTM Specification
1	Handle	Stainless steel
2	Handle Screw	Stainless steel
3	Packing Gland	C63000/B150
4	Sleeve	316 SS/A479
5	Locking Plate	304 SS/A240
6	Locking Screw	Stainless steel
7	Stem	17-4PH/A564
8	Packing Ring	C63000/B150
9	Packing	PTFE/RPTFE/GRAPHITE
10	Packing Washer	17-4PH/A564
11	Body	316 SS/A479
	Lubricant	Molybdenum disulfide

Dimensions

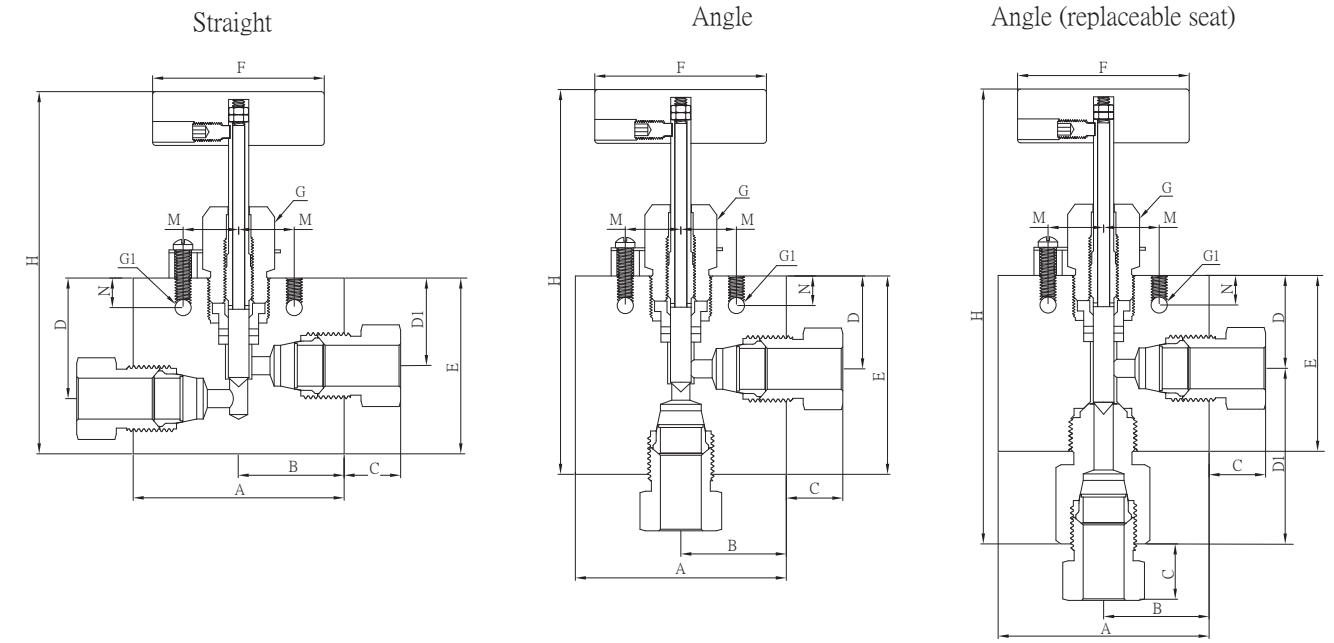

Dimensions (Straight)															
Ordering Number	Connection Type	Orifice in. (mm)	A	B	C	D	D1	E	F	G	G1	H	M	N	Thickness
			in.(mm)												
SS-N15-S4-1	15S4	0.188 (4.77)	2.00 (50.8)	1.00 (25.4)	0.44 (11.2)	1.62 (41.15)	1.19 (30.23)	2.00 (50.8)	3.00 (76.2)	0.75 (19.05)	0.22 (5.59)	4.50 (114.3)	0.62 (15.75)	0.38 (9.65)	0.75 (19.05)
SS-N15-S6-1	15S6	0.250 (6.35)	2.00 (50.8)	1.00 (25.4)	0.53 (13.5)	1.62 (41.15)	1.19 (30.23)	2.00 (50.8)	3.00 (76.2)	0.75 (19.05)	0.22 (5.59)	4.50 (114.3)	0.62 (15.75)	0.38 (9.65)	0.75 (19.05)
SS-N15-S8-1	15S8	0.375 (9.53)	2.50 (63.5)	1.25 (31.75)	0.53 (13.5)	2.38 (60.45)	1.75 (44.45)	2.88 (73.15)	4.00 (101.6)	1.00 (25.4)	0.34 (8.64)	5.95 (151.4)	0.69 (17.53)	0.50 (12.7)	1.00 (25.4)

Dimensions (Angle)															
Ordering Number	Connection Type	Orifice in. (mm)	A	B	C	D	D1	E	F	G	G1	H	M	N	Thickness
			in.(mm)												
SS-N15-S4-2	15S4	0.188 (4.77)	2.00 (50.8)	1.00 (25.4)	0.44 (11.2)	1.19 (30.23)		2.43 (61.72)	3.00 (76.2)	0.75 (19.05)	0.22 (5.59)	5.00 (127.0)	0.62 (15.75)	0.38 (9.65)	0.75 (19.05)
SS-N15-S6-2	15S6	0.250 (6.35)	2.00 (50.8)	1.00 (25.4)	0.53 (13.5)	1.19 (30.23)		2.43 (61.72)	3.00 (76.2)	0.75 (19.05)	0.22 (5.59)	5.00 (127.0)	0.62 (15.75)	0.38 (9.65)	0.75 (19.05)
SS-N15-S8-2	15S8	0.375 (9.53)	2.50 (63.5)	1.25 (31.75)	0.53 (13.5)	1.75 (44.45)		3.38 (85.85)	4.00 (101.6)	1.00 (25.4)	0.34 (8.64)	6.45 (163.8)	0.69 (17.53)	0.50 (12.7)	1.00 (25.4)

Dimensions (Angle/replaceable seat)															
Ordering Number	Connection Type	Orifice in. (mm)	A	B	C	D	D1	E	F	G	G1	H	M	N	Thickness
			in.(mm)												
SS-N15-S4-3	15S4	0.188 (4.77)	2.00 (50.8)	1.00 (25.4)	0.44 (11.2)	1.19 (30.23)	1.88 (47.75)	2.25 (57.15)	3.00 (76.2)	0.75 (19.05)	0.22 (5.59)	5.75 (146.1)	0.62 (15.75)	0.38 (9.65)	0.75 (19.05)
SS-N15-S6-3	15S6	0.250 (6.35)	2.00 (50.8)	1.00 (25.4)	0.53 (13.5)	1.19 (30.23)	2.19 (55.62)	2.25 (57.15)	3.00 (76.2)	0.75 (19.05)	0.22 (5.59)	5.75 (146.1)	0.62 (15.75)	0.38 (9.65)	0.75 (19.05)
SS-N15-S8-3	15S8	0.375 (9.53)	2.50 (63.5)	1.25 (31.75)	0.53 (13.5)	1.75 (44.45)	2.50 (63.5)	3.25 (82.55)	4.00 (101.6)	1.00 (25.4)	0.34 (8.64)	7.51 (190.8)	0.69 (17.53)	0.50 (12.7)	1.00 (25.4)

Dimensions

3-way/2 on pressure

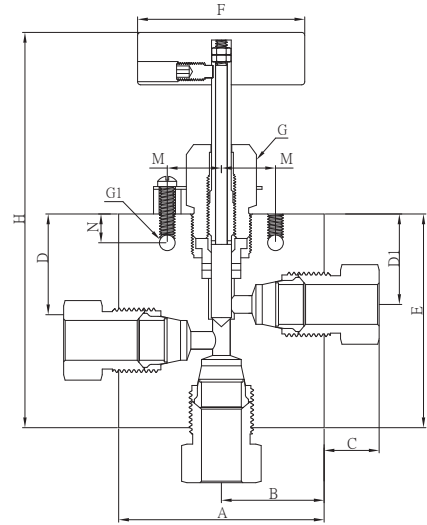

3-way/1 on pressure

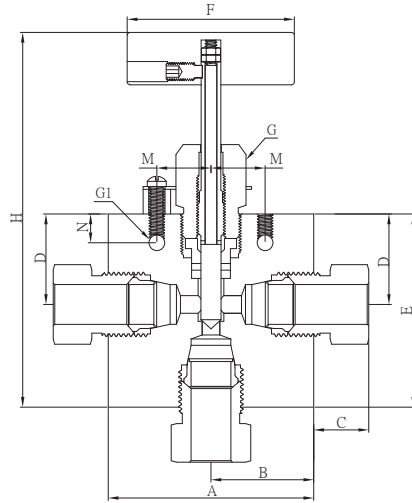

3-way/2 stem manifold

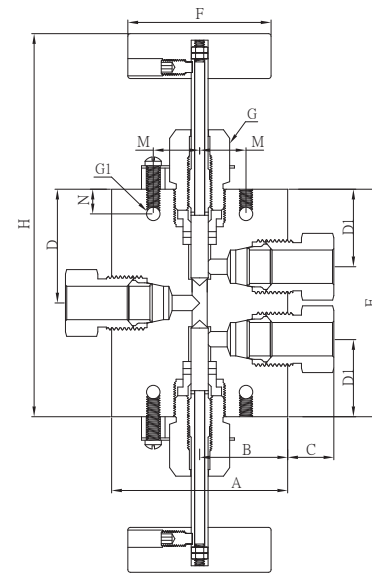

Dimensions (3-way/2 on pressure)

Ordering Number	Connection Type	Orifice in. (mm)	in.(mm)													Thickness
			A	B	C	D	D1	E	F	G	G1	H	M	N		
SS-N15-S4-4	15S4	0.188 (4.77)	2.00 (50.8)	1.00 (25.4)	0.44 (11.2)	1.62 (41.15)	1.19 (30.23)	2.62 (66.55)	3.00 (76.2)	0.75 (19.05)	0.22 (5.59)	5.18 (131.6)	0.62 (15.75)	0.38 (9.65)	0.75 (19.05)	
SS-N15-S6-4	15S6	0.250 (6.35)	2.00 (50.8)	1.00 (25.4)	0.53 (13.5)	1.62 (41.15)	1.19 (30.23)	2.62 (66.55)	3.00 (76.2)	0.75 (19.05)	0.22 (5.59)	5.18 (131.6)	0.62 (15.75)	0.38 (9.65)	0.75 (19.05)	
SS-N15-S8-4	15S8	0.375 (9.53)	2.50 (63.5)	1.25 (31.75)	0.53 (13.5)	2.38 (60.45)	1.75 (44.45)	3.62 (91.95)	4.00 (101.6)	1.00 (25.4)	0.34 (8.64)	6.70 (170.2)	0.69 (17.53)	0.50 (12.7)	1.00 (25.4)	

Dimensions (3-way/1 on pressure)

Ordering Number	Connection Type	Orifice in. (mm)	in.(mm)													Thickness
			A	B	C	D	D1	E	F	G	G1	H	M	N		
SS-N15-S4-5	15S4	0.188 (4.77)	2.00 (50.8)	1.00 (25.4)	0.44 (11.2)	1.19 (30.23)		2.43 (61.72)	3.00 (76.2)	0.75 (19.05)	0.22 (5.59)	5.00 (127.0)	0.62 (15.75)	0.38 (9.65)	0.75 (19.05)	
SS-N15-S6-5	15S6	0.250 (6.35)	2.00 (50.8)	1.00 (25.4)	0.53 (13.5)	1.19 (30.23)		2.43 (61.72)	3.00 (76.2)	0.75 (19.05)	0.22 (5.59)	5.00 (127.0)	0.62 (15.75)	0.38 (9.65)	0.75 (19.05)	
SS-N15-S8-5	15S8	0.375 (9.53)	2.50 (63.5)	1.25 (31.75)	0.53 (13.5)	1.75 (44.45)		3.38 (85.85)	4.00 (101.6)	1.00 (25.4)	0.34 (8.64)	6.45 (163.8)	0.69 (17.53)	0.50 (12.7)	1.00 (25.4)	

Dimensions (3-way/2 stem manifold)

Ordering Number	Connection Type	Orifice in. (mm)	in.(mm)													Thickness
			A	B	C	D	D1	E	F	G	G1	H	M	N		
SS-N15-S4-6	15S4	0.188 (4.77)	2.00 (50.8)	1.00 (25.4)	0.44 (11.2)	1.69 (42.93)	1.19 (30.23)	3.38 (85.85)	3.00 (76.2)	0.75 (19.05)	0.22 (5.59)	5.94 (150.9)	0.62 (15.75)	0.38 (9.65)	0.75 (19.05)	
SS-N15-S6-6	15S6	0.250 (6.35)	2.00 (50.8)	1.00 (25.4)	0.53 (13.5)	1.69 (42.93)	1.19 (30.23)	3.38 (85.85)	3.00 (76.2)	0.75 (19.05)	0.22 (5.59)	5.94 (150.9)	0.62 (15.75)	0.38 (9.65)	0.75 (19.05)	
SS-N15-S8-6	15S8	0.375 (9.53)	2.50 (63.5)	1.25 (31.75)	0.53 (13.5)	2.56 (65.02)	1.75 (44.45)	5.12 (130.1)	4.00 (101.6)	1.00 (25.4)	0.34 (8.64)	8.20 (208.3)	0.69 (17.53)	0.50 (12.7)	1.00 (25.4)	

Note:

1. G is the drill dimension of packing gland mounting hole.
2. G1 is the dimension of bracket mounting hole.
3. Panel mounting drill size: 0.25 all valves.
4. H is the dimension of stem in closed position.
5. All dimensions are for reference only and are subject to change. For dimensions not shown above, please contact the authorized representative or FINELOK.

N20 Series

20,000 psi (1379 bar)

Features

- ☆ Tubing sizes available for 1/4", 3/8", 9/16", 3/4", 1".
- ☆ Non-rotating stem and bar stock body design.
- ☆ Easy to assemble and replace packing.
- ☆ Metal-to-metal seating achieves ideal shutoff, longer stem/seat service lifetime for abrasive flow, excellent corrosion resistance and greater durability for repeated on/off cycles.
- ☆ PTFE is the standard packing material, RPTFE glass, Graphite and Extend stuffing box valve with Graphite also available.
- ☆ Extend stuffing box valve with of Graphite can be operated to 1200°F (649°C).
- ☆ The material of packing gland and stem sleeve have been selected to achieve reduced handle torque and extended thread cycle life.
- ☆ The material of body is 316 SS, The material of stem is 17-4PH SS.
- ☆ Options for Vee or Regulating stem tips.
- ☆ The location of packing is under the thread of valve stem.
- ☆ The locking device of packing gland is reliable.
- ☆ Five flow patterns are available.

Technical Data

Tube OD in.	Connection Type	Orifice in. (mm)	Cv	Pressure @ room temperature psig (bar)
1/4	20S4	0.125 (3.18)	0.31	20,000 (1379)
3/8	20S6	0.219 (5.56)	0.75	20,000 (1379)
9/16	20S9	0.312 (7.92)	1.30	20,000 (1379)
3/4	20S12	0.438 (11.13)	2.50	20,000 (1379)
1	20S16	0.562 (14.27)	4.40	20,000 (1379)

Notes:

- ☆ The value of Cv shown are for 2-way straight valve pattern.
The value of Cv for 2-way angle pattern will be increase about 50% (Base on water).
- ☆ Extreme Temperatures
PTFE is the standard packing material for FINELOK Needle Valve; RPTFE glass, Graphite and Extend stuffing box valve with graphite also available.
Normal Needle valve with PTFE packing can be operated to 450°F(232°C).
Normal Needle valve with RPTFE glass packing can be operated to 600°F(316°C).
Normal Needle valve with Graphite packing can be operated to 800°F(427°C).
Extend stuffing box valve with of Graphite can be operated to 1200°F(649°C).

Flow Data at 100°F (38°C)

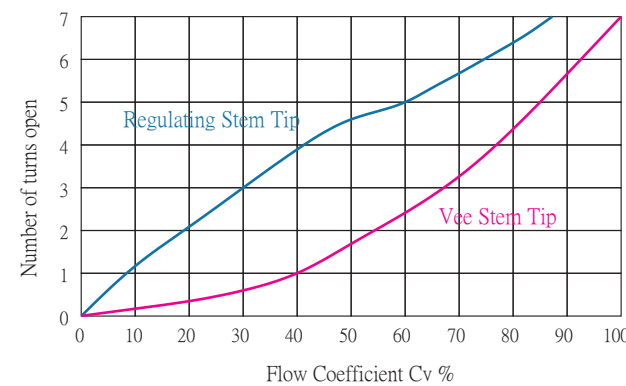

Pressure & Temperature

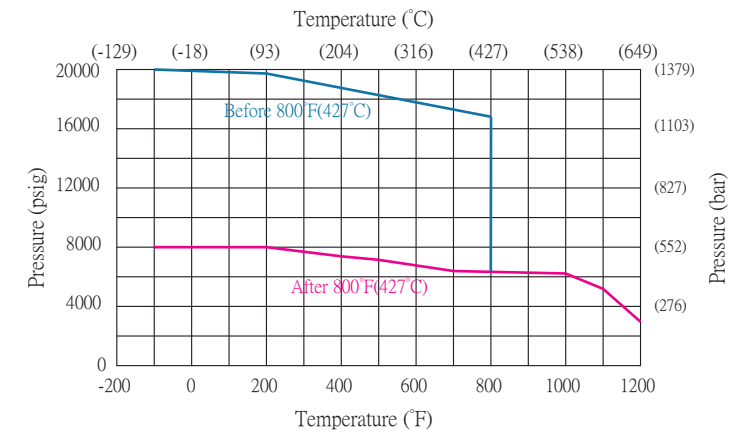

Standard Materials of Construction

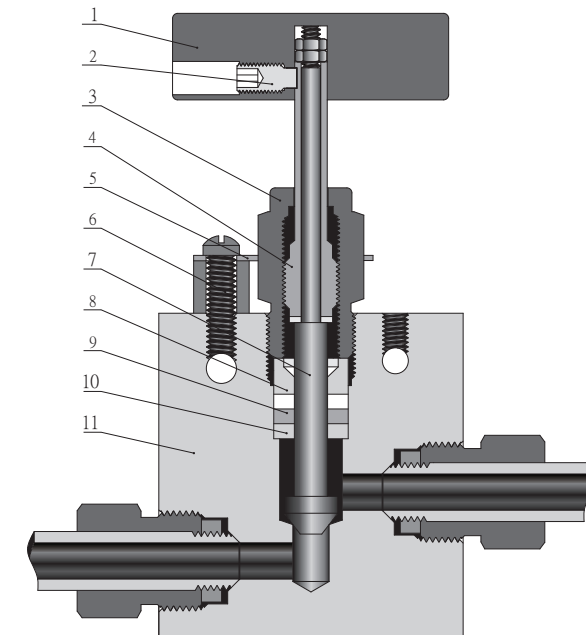

Item	Component	Material Grade/ASTM Specification
1	Handle	Stainless steel
2	Handle Screw	Stainless steel
3	Packing Gland	C63000/B150
4	Sleeve	316 SS/A479
5	Locking Plate	304 SS/A240
6	Locking Screw	Stainless steel
7	Stem	17-4PH/A564
8	Packing Ring	C63000/B150
9	Packing	PTFE/RPTFE/GRAPHITE/Extend stuffing box valve with of Graphite
10	Packing Washer	17-4PH/A564
11	Body	316 SS/A479
	Lubricant	Molybdenum disulfide

Dimensions

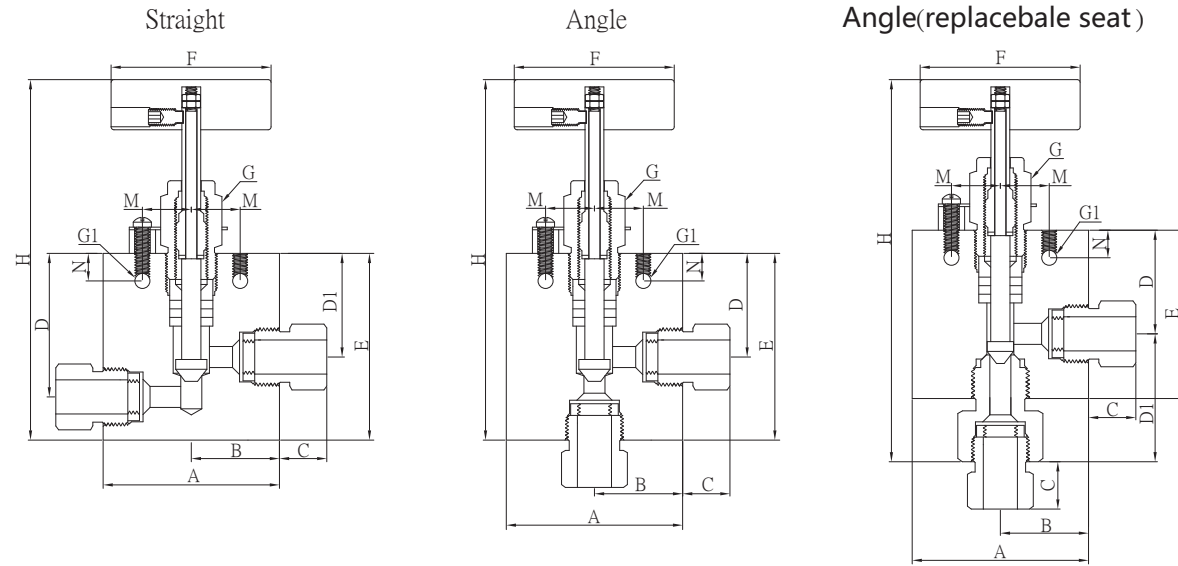

Dimensions (Straight)															
Ordering Number	Connection Type	Orifice in. (mm)	A	B	C	D	D1	E	F	G	G1	H	M	N	Thickness
			in.(mm)												
SS-N20-S4-1	20S4	0.125 (3.18)	2.00 (50.8)	1.00 (25.4)	0.38 (9.65)	1.62 (41.15)	1.19 (30.23)	2.00 (50.8)	3.00 (76.2)	0.75 (19.05)	0.22 (5.59)	4.69 (119.1)	0.62 (15.75)	0.38 (9.65)	0.75 (19.05)
SS-N20-S6-1	20S6	0.219 (5.56)	2.00 (50.8)	1.00 (25.4)	0.47 (11.94)	1.62 (41.15)	1.19 (30.23)	2.00 (50.8)	3.00 (76.2)	0.75 (19.05)	0.22 (5.59)	4.69 (119.1)	0.62 (15.75)	0.38 (9.65)	0.75 (19.05)
SS-N20-S9-1	20S9	0.312 (7.92)	2.50 (63.5)	1.25 (31.75)	0.53 (13.46)	2.38 (60.45)	1.75 (44.45)	2.88 (73.15)	4.00 (101.6)	1.00 (25.4)	0.34 (8.64)	5.93 (150.9)	0.69 (17.53)	0.50 (12.7)	1.00 (25.4)
SS-N20-S12-1	20S12	0.438 (11.13)	3.00 (76.2)	1.50 (38.1)	0.62 (15.75)	3.00 (76.2)	2.25 (57.15)	3.75 (95.25)	10.25 (260.4)	1.12 (28.45)	0.44 (11.18)	7.00 (177.8)	0.88 (22.35)	0.63 (16.0)	1.38 (35.05)
SS-N20-S16-1	20S16	0.562 (14.27)	4.12 (104.6)	2.06 (52.3)	0.63 (16.00)	3.75 (95.25)	2.81 (71.37)	4.63 (117.6)	10.25 (260.4)	1.62 (41.15)	0.56 (14.22)	9.00 (228.6)	1.25 (31.75)	1.13 (28.7)	1.75 (44.45)

Dimensions (Angle)															
Ordering Number	Connection Type	Orifice in. (mm)	A	B	C	D	D1	E	F	G	G1	H	M	N	Thickness
			in.(mm)												
SS-N20-S4-2	20S4	0.125 (3.18)	2.00 (50.8)	1.00 (25.4)	0.38 (9.65)	1.19 (30.23)		2.44 (61.9)	3.00 (76.2)	0.75 (19.05)	0.22 (5.59)	4.81 (122.3)	0.62 (15.75)	0.38 (9.65)	0.75 (19.05)
SS-N20-S6-2	20S6	0.219 (5.56)	2.00 (50.8)	1.00 (25.4)	0.47 (11.94)	1.19 (30.23)		2.44 (61.9)	3.00 (76.2)	0.75 (19.05)	0.22 (5.59)	4.81 (122.3)	0.62 (15.75)	0.38 (9.65)	0.75 (19.05)
SS-N20-S9-2	20S9	0.312 (7.92)	2.50 (63.5)	1.25 (31.75)	0.53 (13.46)	1.75 (44.45)		3.38 (85.85)	4.00 (101.6)	1.00 (25.4)	0.34 (8.64)	6.43 (163.6)	0.69 (17.53)	0.50 (12.7)	1.00 (25.4)
SS-N20-S12-2	20S12	0.438 (11.13)	3.00 (76.2)	1.50 (38.1)	0.62 (15.75)	2.25 (57.15)		4.25 (108.0)	10.25 (260.4)	1.12 (28.45)	0.44 (11.18)	7.50 (190.5)	0.88 (22.35)	0.63 (16.0)	1.38 (35.05)
SS-N20-S16-2	20S16	0.562 (14.27)	4.12 (104.6)	2.06 (52.3)	0.63 (16.00)	2.81 (71.37)		5.12 (130.1)	10.25 (260.4)	1.62 (41.15)	0.56 (14.22)	9.00 (228.6)	1.25 (31.75)	1.13 (28.7)	1.75 (44.45)

Dimensions (Angle/replaceable seat)															
Ordering Number	Connection Type	Orifice in. (mm)	A	B	C	D	D1	E	F	G	G1	H	M	N	Thickness
			in.(mm)												
SS-N20-S4-3	20S4	0.125 (3.18)	2.00 (50.8)	1.00 (25.4)	0.38 (9.65)	1.19 (30.23)	2.13 (53.98)	2.25 (57.15)	3.00 (76.2)	0.75 (19.05)	0.22 (5.59)	5.75 (146.1)	0.62 (15.75)	0.38 (9.65)	0.75 (19.05)
SS-N20-S6-3	20S6	0.219 (5.56)	2.00 (50.8)	1.00 (25.4)	0.47 (11.94)	1.19 (30.23)	2.13 (53.98)	2.25 (57.15)	3.00 (76.2)	0.75 (19.05)	0.22 (5.59)	5.75 (146.1)	0.62 (15.75)	0.38 (9.65)	0.75 (19.05)
SS-N20-S9-3	20S9	0.312 (7.92)	2.50 (63.5)	1.25 (31.75)	0.53 (13.46)	1.75 (44.45)	2.50 (63.5)	3.13 (79.38)	4.00 (101.6)	1.00 (25.4)	0.34 (8.64)	7.34 (186.7)	0.69 (17.53)	0.50 (12.7)	1.00 (25.4)
SS-N20-S12-3	20S12	0.438 (11.13)	3.00 (76.2)	1.50 (38.1)	0.62 (15.75)	2.25 (57.15)	3.44 (87.38)	4.25 (108.0)	10.25 (260.4)	1.12 (28.45)	0.44 (11.18)	9.00 (228.6)	0.88 (22.35)	0.63 (16.0)	1.38 (35.05)
SS-N20-S16-3	20S16	0.562 (14.27)	4.12 (104.6)	2.06 (52.3)	0.63 (16.00)	2.69 (68.33)	4.38 (111.1)	5.25 (133.4)	10.25 (260.4)	1.62 (41.15)	0.56 (14.22)	11.00 (279.7)	1.25 (31.75)	1.13 (28.7)	1.75 (44.45)

Dimensions

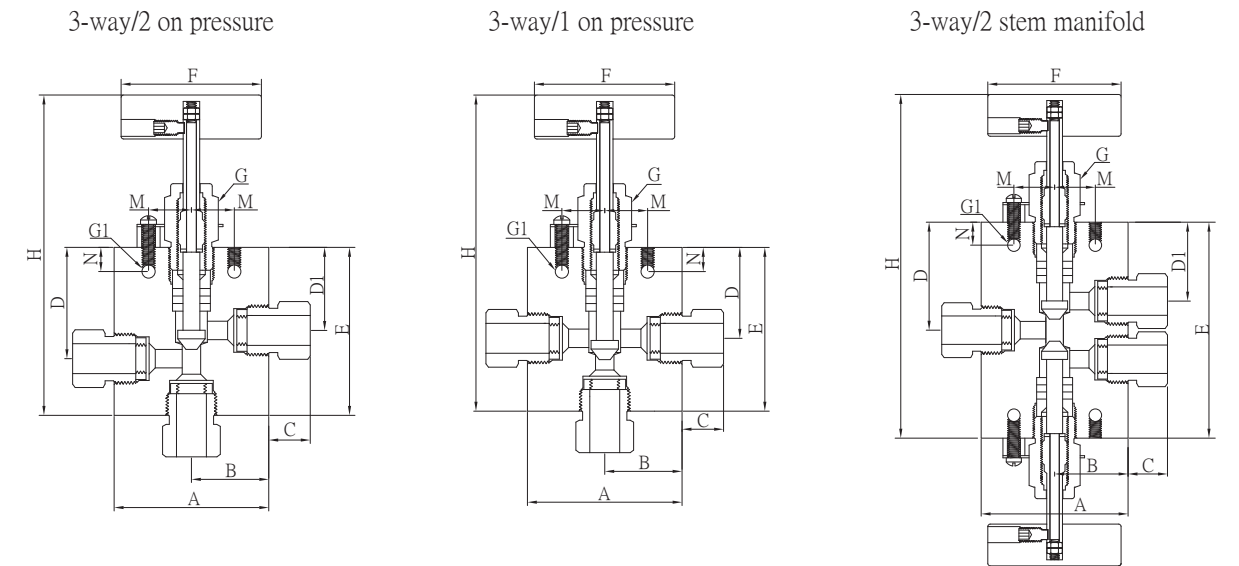

Dimensions (3-way/2 on pressure)															
Ordering Number	Connection Type	Orifice in. (mm)	A	B	C	D	D1	E	F	G	G1	H	M	N	Thickness
			in.(mm)												
SS-N20-S4-4	20S4	0.125 (3.18)	2.00 (50.8)	1.00 (25.4)	0.38 (9.65)	1.63 (41.28)	1.19 (30.23)	2.63 (66.68)	3.00 (76.2)	0.75 (19.05)	0.22 (5.59)	5.00 (127.0)	0.62 (15.75)	0.38 (9.65)	0.75 (19.05)
SS-N20-S6-4	20S6	0.219 (5.56)	2.00 (50.8)	1.00 (25.4)	0.47 (11.94)	1.63 (41.28)	1.19 (30.23)	2.63 (66.68)	3.00 (76.2)	0.75 (19.05)	0.22 (5.59)	5.00 (127.0)	0.62 (15.75)	0.38 (9.65)	0.75 (19.05)
SS-N20-S9-4	20S9	0.312 (7.92)	2.50 (63.5)	1.25 (31.75)	0.53 (13.46)	2.38 (60.45)	1.75 (44.45)	3.63 (92.08)	4.00 (101.6)	1.00 (25.4)	0.34 (8.64)	6.51 (165.6)	0.69 (17.53)	0.50 (12.7)	1.00 (25.4)
SS-N20-S12-4	20S12	0.438 (11.13)	3.00 (76.2)	1.50 (38.1)	0.62 (15.75)	3.00 (76.20)	2.25 (57.15)	4.63 (117.5)	10.25 (260.4)	1.12 (28.45)	0.44 (11.18)	7.88 (200.0)	0.88 (22.35)	0.63 (16.0)	1.38 (35.05)
SS-N20-S16-4	20S16	0.562 (14.27)	4.12 (104.6)	2.06 (52.3)	0.63 (16.00)	3.75 (95.25)	2.81 (71.37)	5.88 (149.4)	10.25 (260.4)	1.62 (41.15)	0.56 (14.22)	9.75 (247.9)	1.25 (31.75)	1.13 (28.7)	1.75 (44.45)

Dimensions (3-way/1 on pressure)															
Ordering Number	Connection Type	Orifice in. (mm)	A	B	C	D	D1	E	F	G	G1	H	M	N	Thickness
			in.(mm)												
SS-N20-S4-5	20S4	0.125 (3.18)	2.00 (50.8)	1.00 (25.4)	0.38 (9.65)	1.19 (30.23)		2.44 (61.90)	3.00 (76.2)	0.75 (19.05)	0.22 (5.59)	4.81 (122.3)	0.62 (15.75)	0.38 (9.65)	0.75 (19.05)
SS-N20-S6-5	20S6	0.219 (5.56)	2.00 (50.8)	1.00 (25.4)	0.47 (11.94)	1.19 (30.23)		2.44 (61.90)	3.00 (76.2)	0.75 (19.05)	0.22 (5.59)	4.81 (122.3)	0.62 (15.75)	0.38 (9.65)	0.75 (19.05)
SS-N20-S9-5	20S9	0.312 (7.92)	2.50 (63.5)	1.25 (31.75)	0.53 (13.46)	1.75 (44.45)		3.38 (85.85)	4.00 (101.6)	1.00 (25.4)	0.34 (8.64)	6.31 (160.5)	0.69 (17.53)	0.50 (12.7)	1.00 (25.4)
SS-N20-S12-5	20S12	0.438 (11.13)	3.00 (76.2)	1.50 (38.1)	0.62 (15.75)	2.25 (57.15)		4.25 (108.0)	10.25 (260.4)	1.12 (28.45)	0.44 (11.18)	7.5 (190.5)	0.88 (22.35)	0.63 (16.0)	1.38 (35.05)
SS-N20-S16-5	20S16	0.562 (14.27)	4.12 (104.6)	2.06 (52.3)	0.63 (16.00)	2.81 (71.37)		5.12 (103.1)	10.25 (260.4)	1.62 (41.15)	0.56 (14.22)	9.09 (231.1)	1.25 (31.75)	1.13 (28.7)	1.75 (44.45)

Dimensions (3-way/2 stem manifold)															
Ordering Number	Connection Type	Orifice in. (mm)	A	B	C	D	D1	E	F	G	G1	H	M	N	Thickness
			in.(mm)												
SS-N20-S4-6	20S4	0.125 (3.18)	2.00 (50.8)	1.00 (25.4)	0.38 (9.65)	1.69 (42.85)	1.19 (30.15)	3.38 (85.73)	3.00 (76.2)	0.75 (19.05)	0.22 (5.59)	8.13 (206.4)	0.62 (15.75)	0.38 (9.65)	0.75 (19.05)
SS-N20-S6-6	20S6	0.219 (5.56)	2.00 (50.8)	1.00 (25.4)	0.47 (11.94)	1.69 (42.85)	1.19 (30.15)	3.38 (85.73)	3.00 (76.2)	0.75 (19.05)	0.22 (5.59)	8.13 (206.4)	0.62 (15.75)	0.38 (9.65)	0.75 (19.05)
SS-N20-S9-6	20S9	0.312 (7.92)	2.50 (63.5)	1.25 (31.75)	0.53 (13.46)	2.56 (65.07)	1.75 (44.45)	5.13 (130.2)	4.00 (101.6)	1.00 (25.4)	0.34 (8.64)	11.31 (287.6)	0.69 (17.53)	0.50 (12.7)	1.00 (25.4)
SS-N20-S12-6	20S12	0.438 (11.13)	3.00 (76.2)	1.50 (38.1)	0.62 (15.75)	3.00 (76.2)	2.25 (57.15)	6.50 (165.1)	10.25 (260.4)	1.12 (28.45)	0.44 (11.18)	13.0 (330.2)	0.88 (22.35)	0.63 (16.0)	1.38 (35.05)
SS-N20-S16-6	20S16	0.562 (14.27)	4.12 (104.6)	2.06 (52.3)	0.63 (16.00)	3.75 (95.25)	2.81 (71.37)	7.50 (190.5)	10.25 (260.4)	1.62 (41.15)	0.56 (14.22)	15.44 (392.4)	1.25 (31.75)	1.13 (28.7)	1.75 (44.45)

Note:

1. G is the drill dimension of packing gland mounting hole.
2. G1 is the dimension of bracket mounting hole.
3. Panel mounting drill size: 0.25 all valves.
4. H is the dimension of stem in closed position.
5. All dimensions are for reference only and are subject to change. For dimensions not shown above, please contact the authorized representative or FINELOK.

N30 Series

30,000 psi (2068 bar)

Features

- ☆ Tubing sizes available for 1/4", 3/8", 9/16".
- ☆ Non-rotating stem and bar stock body design.
- ☆ Easy to assemble and replace packing.
- ☆ Metal-to-metal seating achieves ideal shutoff, longer stem/seat service lifetime for abrasive flow, excellent corrosion resistance and greater durability for repeated on/off cycles.
- ☆ PTFE is the standard packing material, RPTFE glass and Graphite also available.
- ☆ Extend stuffing box valve with of Graphite can be operated to 1200°F (649°C).
- ☆ The material of packing gland and stem sleeve have been selected to achieve reduced handle torque and extended thread cycle life.
- ☆ The material of valve body is 316SS, The material of valve stem is 17-4PH SS.
- ☆ Options for Vee or Regulating stem tips.
- ☆ The locking device of packing gland is reliable.
- ☆ Five flow patterns are available.

Technical Data

Tube OD in.	Connection Type	Orifice in. (mm)	Rated Cv	Pressure @ Room temperature psig (bar)
1/4	60S4	0.094 (2.39)	0.12	30,000 (2068)
3/8	60S6	0.125 (3.18)	0.23	30,000 (2068)
9/16	60S9	0.125 (3.18)	0.33	30,000 (2068)

Notes:

- ☆ The value of Cv shown are for 2-way straight valve pattern. The value of Cv for 2-way angle pattern will be increase about 50% (Base on water).
- ☆ Extreme Temperatures
PTFE is the standard packing material for FINELOK Needle valve; RPTFE glass, Graphite and Extend stuffing box valve with graphite also available.
Normal Needle valve with PTFE packing can be operated to 450°F(232°C).
Normal Needle valve with RPTFE glass packing can be operated to 600°F(316°C).
Normal Needle valve with Graphite packing can be operated to 800°F(427°C).
Extend stuffing box valve with of Graphite can be operated to 1200°F(649°C).

Flow Data at 100°F (38°C)

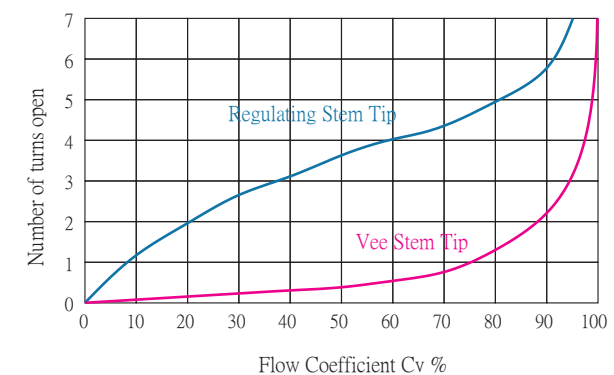

Pressure & Temperature

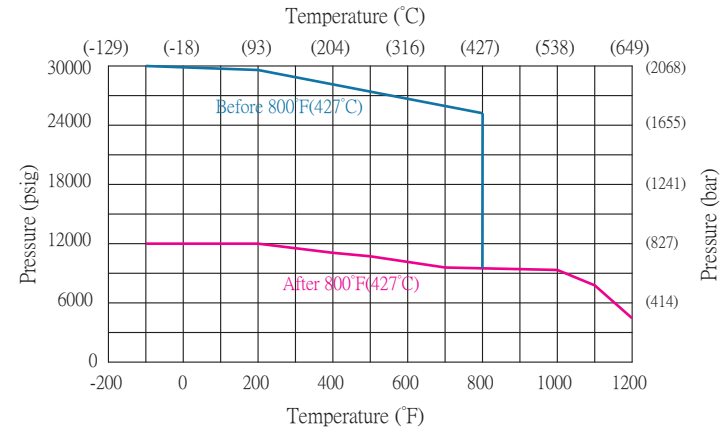

Standard Materials of Construction

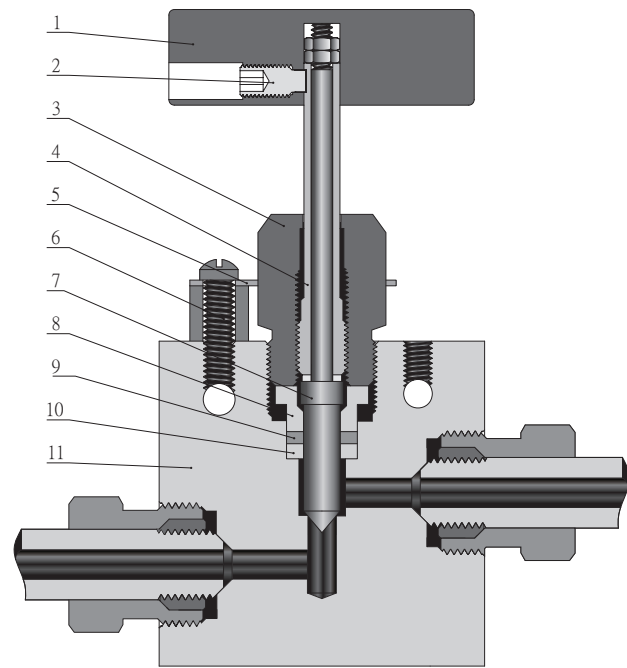

Item	Component	Material Grade/ASTM Specification
1	Handle	Stainless steel
2	Handle Screw	Stainless steel
3	Packing Gland	C63000/B150
4	Sleeve	316 SS/A479
5	Locking Plate	304 SS/A240
6	Locking Screw	Stainless steel
7	Stem	17-4PH/A564
8	Packing Ring	17-4PH/A564
9	Packing	PTFE/RPTFE/GRAPHITE/Extend stuffing box valve with of Graphite
10	Packing Washer	17-4PH/A564
11	Body	316 SS/A479
	Lubricant	Molybdenum disulfide

Dimensions

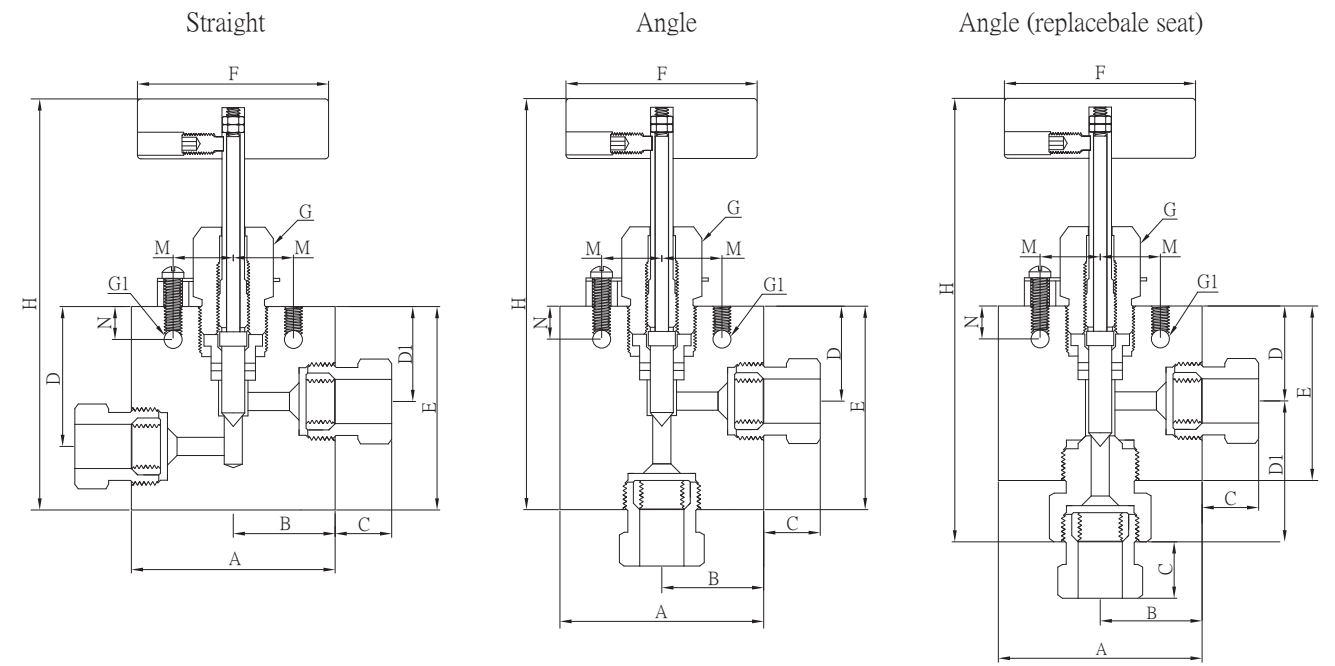

Dimensions (Straight)															
Ordering Number	Connection Type	Orifice in. (mm)	A	B	C	D	D1	E	F	G	G1	H	M	N	Thickness
			in.(mm)												
SS-N30-S4-1	60S4	0.094 (2.39)	2.00 (50.8)	1.00 (25.4)	0.50 (12.7)	1.50 (38.1)	1.12 (28.45)	2.00 (50.8)	3.00 (76.2)	1.00 (25.4)	0.22 (5.59)	4.62 (117.4)	0.69 (17.53)	0.38 (9.65)	1.00 (25.4)
SS-N30-S6-1	60S6	0.125 (3.18)	2.00 (50.8)	1.00 (25.4)	0.53 (13.46)	1.50 (38.1)	1.12 (28.45)	2.00 (50.8)	3.00 (76.2)	1.00 (25.4)	0.22 (5.59)	4.68 (118.9)	0.69 (17.53)	0.38 (9.65)	1.00 (25.4)
SS-N30-S9-1	60S9	0.125 (3.18)	2.62 (66.55)	1.31 (33.27)	0.81 (20.57)	1.56 (39.62)	1.12 (28.45)	2.44 (61.98)	3.00 (76.2)	1.00 (25.4)	0.28 (7.11)	5.06 (128.5)	0.69 (17.53)	0.38 (9.65)	1.50 (38.1)

Dimensions (Angle)															
Ordering Number	Connection Type	Orifice in. (mm)	A	B	C	D	D1	E	F	G	G1	H	M	N	Thickness
			in.(mm)												
SS-N30-S4-2	60S4	0.094 (2.39)	2.00 (50.8)	1.00 (25.4)	0.50 (12.7)	1.12 (28.45)		2.00 (50.8)	3.00 (76.2)	1.00 (25.4)	0.22 (5.59)	4.62 (117.4)	0.69 (17.53)	0.38 (9.65)	1.00 (25.4)
SS-N30-S6-2	60S6	0.125 (3.18)	2.00 (50.8)	1.00 (25.4)	0.53 (13.46)	1.12 (28.45)		2.13 (54.0)	3.00 (76.2)	1.00 (25.4)	0.22 (5.59)	4.68 (118.9)	0.69 (17.53)	0.38 (9.65)	1.00 (25.4)
SS-N30-S9-2	60S9	0.125 (3.18)	2.62 (66.55)	1.31 (33.27)	0.81 (20.57)	1.12 (28.45)		2.44 (61.98)	3.00 (76.2)	1.00 (25.4)	0.28 (7.11)	5.06 (128.5)	0.69 (17.53)	0.38 (9.65)	1.50 (38.1)

Dimensions (Angle/replaceable seat)															
Ordering Number	Connection Type	Orifice in. (mm)	A	B	C	D	D1	E	F	G	G1	H	M	N	Thickness
			in.(mm)												
SS-N30-S4-3	60S4	0.094 (2.39)	2.00 (50.8)	1.00 (25.4)	0.50 (12.7)	1.12 (28.45)	2.06 (52.32)	2.38 (60.45)	3.00 (76.2)	1.00 (25.4)	0.22 (5.59)	5.80 (147.3)	0.69 (17.53)	0.38 (9.65)	1.00 (25.4)
SS-N30-S6-3	60S6	0.125 (3.18)	2.00 (50.8)	1.00 (25.4)	0.53 (13.46)	1.12 (28.45)	2.31 (58.67)	2.38 (60.45)	3.00 (76.2)	1.00 (25.4)	0.22 (5.59)	6.05 (153.7)	0.69 (17.53)	0.38 (9.65)	1.00 (25.4)
SS-N30-S9-3	60S9	0.125 (3.18)	2.62 (66.55)	1.31 (33.27)	0.81 (20.57)	1.19 (30.23)	2.62 (66.55)	2.44 (61.98)	3.00 (76.2)	1.00 (25.4)	0.28 (7.11)	6.45 (163.8)	0.69 (17.53)	0.38 (9.65)	1.50 (38.1)

Dimensions

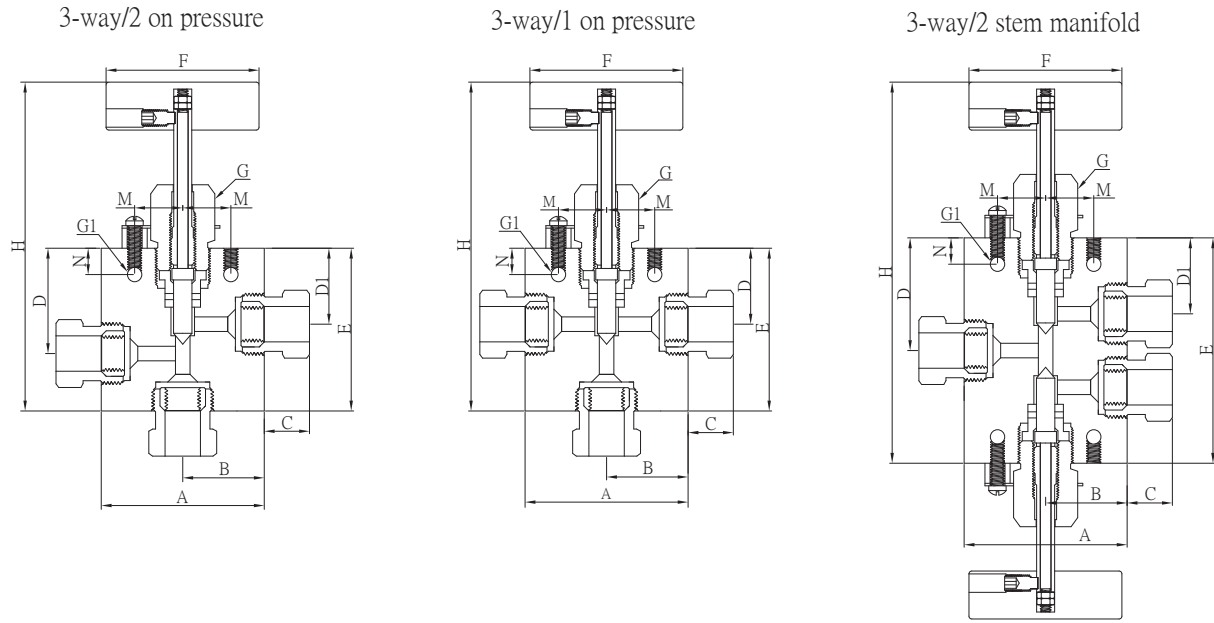

Dimensions (3-way/2 on pressure)															
Ordering Number	Connection Type	Orifice in. (mm)	A	B	C	D	D1	E	F	G	G1	H	M	N	Thickness
			in.(mm)												
SS-N30-S4-4	60S4	0.094 (2.39)	2.00 (50.8)	1.00 (25.4)	0.50 (12.7)	1.50 (38.1)	1.12 (28.45)	2.12 (53.85)	3.00 (76.2)	1.00 (25.4)	0.22 (5.59)	4.74 (120.4)	0.69 (17.53)	0.38 (9.65)	1.00 (25.4)
SS-N30-S6-4	60S6	0.125 (3.18)	2.00 (50.8)	1.00 (25.4)	0.53 (13.46)	1.50 (38.1)	1.12 (28.45)	2.50 (63.5)	3.00 (76.2)	1.00 (25.4)	0.22 (5.59)	5.12 (130.1)	0.69 (17.53)	0.38 (9.65)	1.00 (25.4)
SS-N30-S9-4	60S9	0.125 (3.18)	2.62 (66.55)	1.31 (33.27)	0.81 (20.57)	1.56 (39.62)	1.12 (28.45)	2.88 (73.15)	3.00 (76.2)	1.00 (25.4)	0.28 (7.11)	5.49 (139.5)	0.69 (17.53)	0.38 (9.65)	1.50 (38.1)

Dimensions (3-way/1 on pressure)															
Ordering Number	Connection Type	Orifice in. (mm)	A	B	C	D	D1	E	F	G	G1	H	M	N	Thickness
			in.(mm)												
SS-N30-S4-5	60S4	0.094 (2.39)	2.00 (50.8)	1.00 (25.4)	0.50 (12.7)	1.12 (28.45)		2.00 (50.8)	3.00 (76.2)	1.00 (25.4)	0.22 (5.59)	4.62 (117.4)	0.69 (17.53)	0.38 (9.65)	1.00 (25.4)
SS-N30-S6-5	60S6	0.125 (3.18)	2.00 (50.8)	1.00 (25.4)	0.53 (13.46)	1.12 (28.45)		2.00 (50.8)	3.00 (76.2)	1.00 (25.4)	0.22 (5.59)	4.74 (120.4)	0.69 (17.53)	0.38 (9.65)	1.00 (25.4)
SS-N30-S9-5	60S9	0.125 (3.18)	2.62 (66.55)	1.31 (33.27)	0.81 (20.57)	1.12 (28.45)		2.44 (61.98)	3.00 (76.2)	1.00 (25.4)	0.28 (7.11)	5.12 (130.1)	0.69 (17.53)	0.38 (9.65)	1.50 (38.1)

Dimensions (3-way/2 stem manifold)															
Ordering Number	Connection Type	Orifice in. (mm)	A	B	C	D	D1	E	F	G	G1	H	M	N	Thickness
			in.(mm)												
SS-N30-S4-6	60S4	0.094 (2.39)	2.00 (50.8)	1.00 (25.4)	0.50 (12.7)	1.53 (38.86)	1.12 (28.45)	3.06 (77.72)	3.00 (76.2)	1.00 (25.4)	0.22 (5.59)	5.68 (144.3)	0.69 (17.53)	0.38 (9.65)	1.00 (25.4)
SS-N30-S6-6	60S6	0.125 (3.18)	2.00 (50.8)	1.00 (25.4)	0.53 (13.46)	1.62 (41.15)	1.12 (28.45)	3.25 (82.55)	3.00 (76.2)	1.00 (25.4)	0.22 (5.59)	5.87 (149.1)	0.69 (17.53)	0.38 (9.65)	1.00 (25.4)
SS-N30-S9-6	60S9	0.125 (3.18)	2.62 (66.55)	1.31 (33.27)	0.81 (20.57)	1.88 (47.75)	1.12 (28.45)	3.75 (95.25)	3.00 (76.2)	1.00 (25.4)	0.28 (7.11)	6.37 (161.8)	0.69 (17.53)	0.38 (9.65)	1.50 (38.1)

- Note:
- G is the drill dimension of packing gland mounting hole.
 - G1 is the dimension of bracket mounting hole.
 - Panel mounting drill size: 0.25 all valves.
 - H is the dimension of stem in closed position.
 - All dimensions are for reference only and are subject to change. For dimensions not shown above, please contact the authorized representative or FINELOK.

N60 Series
60,000 psi (4137 bar)

Features

- ☆ Tubing sizes available for 1/4", 3/8", 9/16".
- ☆ Non-rotating stem and bar stock body design.
- ☆ Easy to assemble and replace packing.
- ☆ Metal-to-metal seating achieves ideal shutoff, longer stem/seat service lifetime for abrasive flow, excellent corrosion resistance and greater durability for repeated on/off cycles.
- ☆ Nylon is the standard packing material, RPTFE glass and Graphite also available.
- ☆ Extend stuffing box valve with of Graphite can be operated to 1200°F (649°C).
- ☆ The material of packing gland and stem sleeve have been selected to achieve reduced handle torque and extended thread cycle life.
- ☆ The material of valve body is 316SS, The material of valve stem is 17-4PH SS.
- ☆ Options for Vee or Regulating stem tips.
- ☆ The locking device of packing gland is reliable.
- ☆ Five flow patterns are available.

Technical Data

Tube OD in.	Connection Type	Orifice in. (mm)	Rated Cv	Pressure @ Room temperature psig (bar)
1/4	60S4	0.062 (1.57)	0.08	60,000 (4137)
3/8	60S6	0.062 (1.57)	0.09	60,000 (4137)
9/16	60S9	0.078 (1.98)	0.14	60,000 (4137)

- Notes:
- ☆ The value of Cv shown are for 2-way straight valve pattern. The value of Cv for 2-way angle pattern will be increase about 50% (Base on water).
 - ☆ Extreme Temperatures
Nylon is the standard packing material for FINELOK Needle Valve; RPTFE glass, Graphite and Extend stuffing box valve with graphite also available.
Normal Needle valve with Nylon packing can be operated to 230°F(110°C).
Normal Needle valve with RPTFE glass packing can be operated to 600°F(316°C).
Normal Needle valve with Graphite packing can be operated to 800°F(427°C).
Extend stuffing box valve with of Graphite can be operated to 1200°F(649°C).

Flow Data at 100°F (38°C)

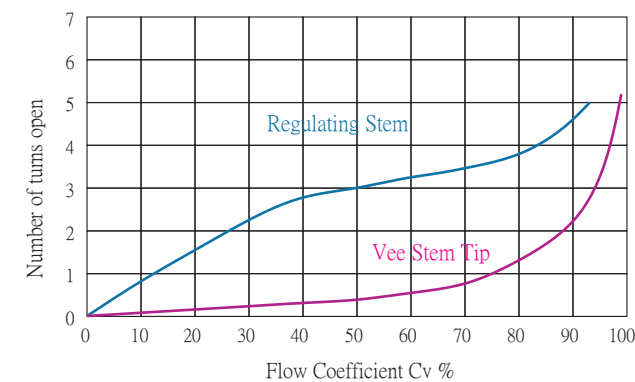

Pressure & Temperature

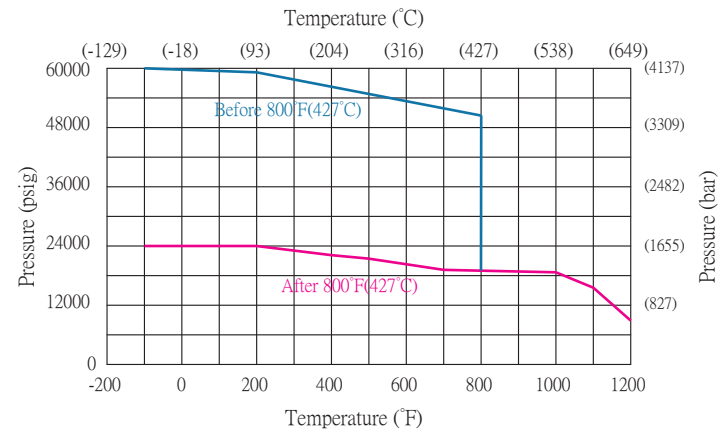

Standard Materials of Construction

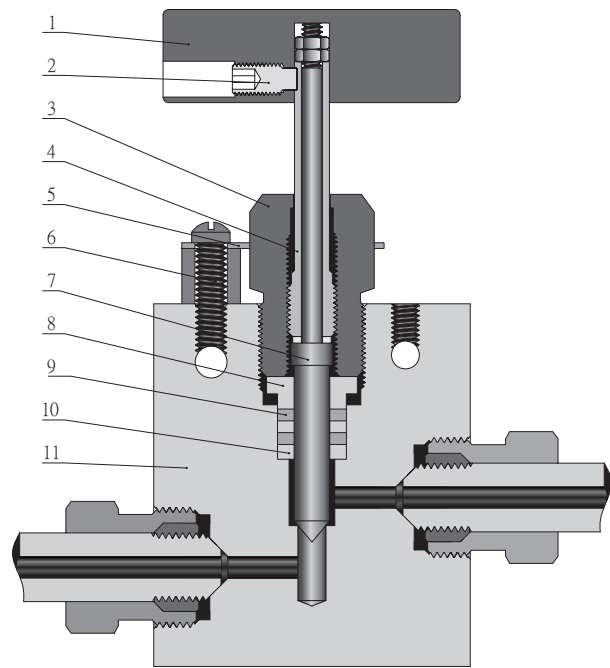

Item	Component	Material Grade/ASTM Specification
1	Handle	Stainless steel
2	Handle Screw	Stainless steel
3	Packing Gland	C63000/B150
4	Sleeve	316 SS/A479
5	Locking Plate	304 SS/A240
6	Locking Screw	Stainless steel
7	Stem	17-4PH/A564
8	Packing Ring	17-4PH/A564
9	Packing	Nylon/RPTFE/GRAPHITE/Extend stuffing box valve with of Graphite
10	Packing Washer	17-4PH/A564
11	Body	316 SS/A479
	Lubricant	Molybdenum disulfide

Standard Materials of Construction

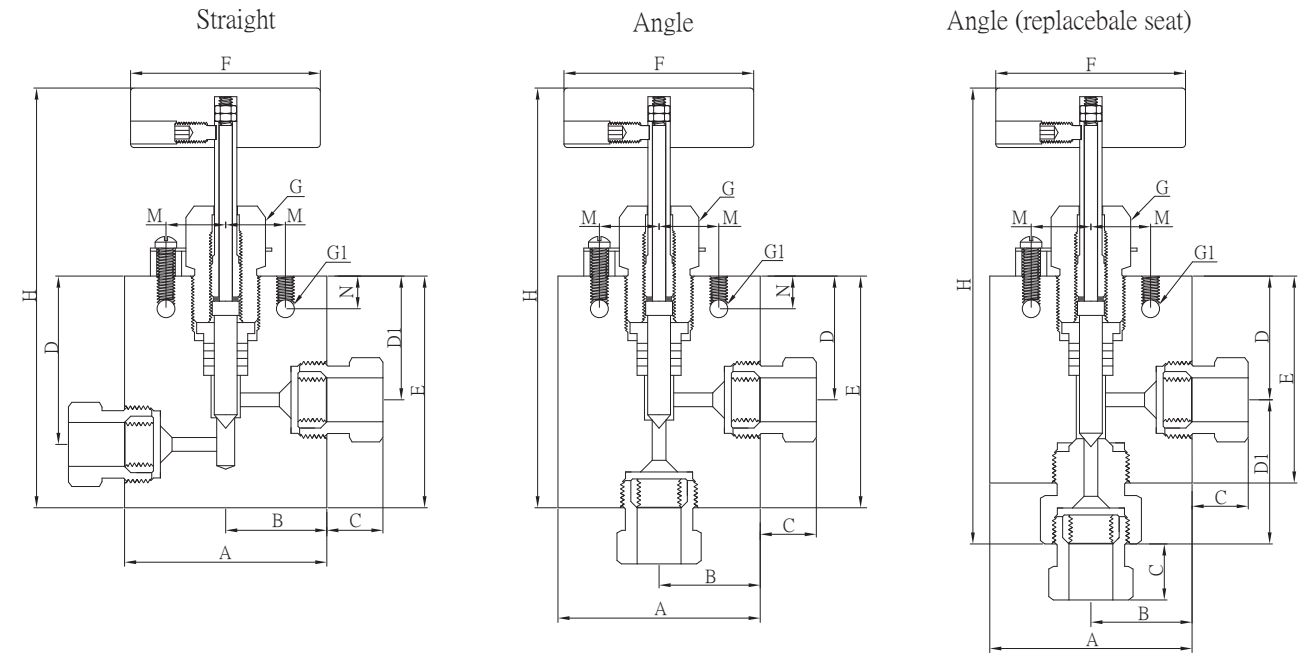

Dimensions (Straight)															
Ordering Number	Connection Type	Orifice in. (mm)	A	B	C	D	D1	E	F	G	G1	H	M	N	Thickness
			in.(mm)												
SS-N60-S4-1	60S4	0.062 (1.57)	2.00 (50.8)	1.00 (25.4)	0.50 (12.7)	1.69 (42.93)	1.31 (33.27)	2.13 (54.0)	3.00 (76.2)	1.00 (25.4)	0.22 (5.59)	4.75 (120.7)	0.69 (17.53)	0.38 (9.65)	1.00 (25.4)
SS-N60-S6-1	60S6	0.062 (1.57)	2.00 (50.8)	1.00 (25.4)	0.53 (13.46)	1.69 (42.93)	1.31 (33.27)	2.25 (57.15)	3.00 (76.2)	1.00 (25.4)	0.22 (5.59)	4.75 (120.7)	0.69 (17.53)	0.38 (9.65)	1.00 (25.4)
SS-N60-S9-1	60S9	0.078 (1.98)	2.62 (66.55)	1.31 (33.27)	0.72 (18.29)	1.75 (44.45)	1.31 (33.27)	2.50 (63.5)	3.00 (76.2)	1.00 (25.4)	0.28 (7.11)	5.13 (130.3)	0.69 (17.53)	0.38 (9.65)	1.50 (38.1)

Dimensions (Angle)															
Ordering Number	Connection Type	Orifice in. (mm)	A	B	C	D	D1	E	F	G	G1	H	M	N	Thickness
			in.(mm)												
SS-N60-S4-2	60S4	0.062 (1.57)	2.00 (50.8)	1.00 (25.4)	0.50 (12.7)	1.31 (33.27)		2.38 (60.45)	3.00 (76.2)	1.00 (25.4)	0.22 (5.59)	5.00 (127.0)	0.69 (17.53)	0.38 (9.65)	1.00 (25.4)
SS-N60-S6-2	60S6	0.062 (1.57)	2.00 (50.8)	1.00 (25.4)	0.53 (13.46)	1.31 (33.27)		2.62 (66.55)	3.00 (76.2)	1.00 (25.4)	0.22 (5.59)	5.25 (133.4)	0.69 (17.53)	0.38 (9.65)	1.00 (25.4)
SS-N60-S9-2	60S9	0.078 (1.98)	2.62 (66.55)	1.31 (33.27)	0.72 (18.29)	1.31 (33.27)		2.81 (71.37)	3.00 (76.2)	1.00 (25.4)	0.28 (7.11)	5.44 (138.2)	0.69 (17.53)	0.38 (9.65)	1.50 (38.1)

Dimensions (Angle/replaceable seat)															
Ordering Number	Connection Type	Orifice in. (mm)	A	B	C	D	D1	E	F	G	G1	H	M	N	Thickness
			in.(mm)												
SS-N60-S4-3	60S4	0.062 (1.57)	2.00 (50.8)	1.00 (25.4)	0.50 (12.7)	1.31 (33.27)	2.12 (53.85)	2.62 (66.55)	3.00 (76.2)	1.00 (25.4)	0.22 (5.59)	6.28 (159.5)	0.69 (17.53)	0.38 (9.65)	1.00 (25.4)
SS-N60-S6-3	60S6	0.062 (1.57)	2.00 (50.8)	1.00 (25.4)	0.53 (13.46)	1.31 (33.27)	2.36 (59.94)	2.62 (66.55)	3.00 (76.2)	1.00 (25.4)	0.22 (5.59)	6.52 (165.6)	0.69 (17.53)	0.38 (9.65)	1.00 (25.4)
SS-N60-S9-3	60S9	0.078 (1.98)	2.62 (66.55)	1.31 (33.27)	0.72 (18.29)	1.31 (33.27)	2.68 (68.07)	2.62 (66.55)	3.00 (76.2)	1.00 (25.4)	0.28 (7.11)	6.90 (175.3)	0.69 (17.53)	0.38 (9.65)	1.50 (38.1)

Dimensions

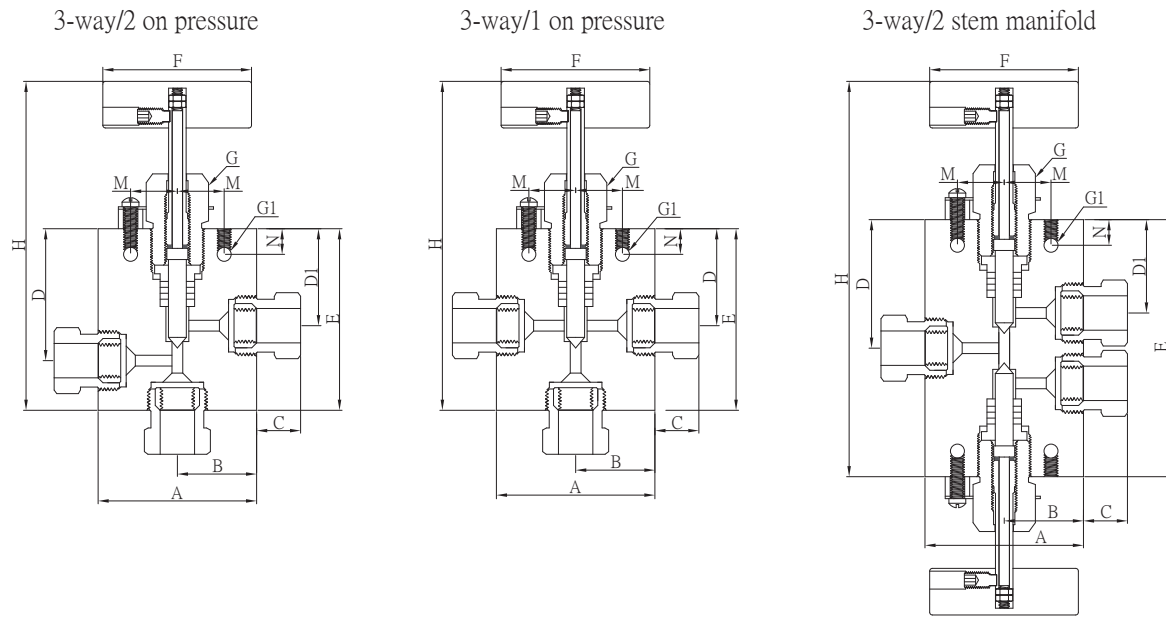

Ordering Information

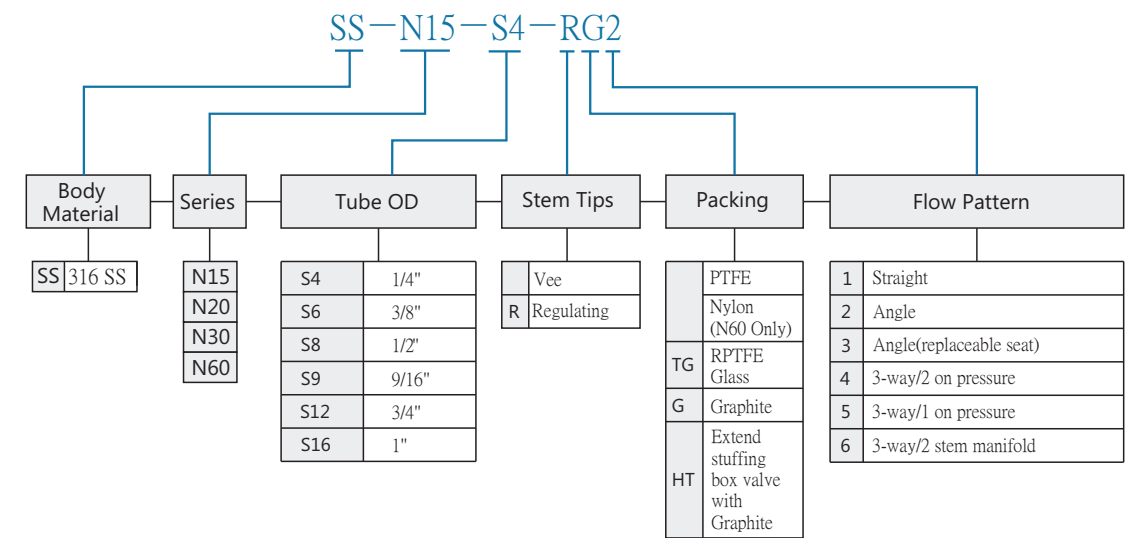

Dimensions (3-way/2 on pressure)															
Ordering Number	Connection Type	Orifice in. (mm)	A	B	C	D	D1	E	F	G	G1	H	M	N	Thickness
			in.(mm)												
SS-N60-S4-4	60S4	0.062 (1.57)	2.00 (50.8)	1.00 (25.4)	0.50 (12.7)	1.69 (42.93)	1.31 (33.27)	2.38 (60.45)	3.00 (76.2)	1.00 (25.4)	0.22 (5.59)	4.75 (120.7)	0.69 (17.53)	0.38 (9.65)	1.00 (25.4)
SS-N60-S6-4	60S6	0.062 (1.57)	2.00 (50.8)	1.00 (25.4)	0.53 (13.46)	1.69 (42.93)	1.31 (33.27)	2.75 (68.85)	3.00 (76.2)	1.00 (25.4)	0.22 (5.59)	4.87 (123.7)	0.69 (17.53)	0.38 (9.65)	1.00 (25.4)
SS-N60-S9-4	60S9	0.078 (1.98)	2.62 (66.55)	1.31 (33.27)	0.72 (18.29)	1.75 (44.45)	1.31 (33.27)	3.03 (76.96)	3.00 (76.2)	1.00 (25.4)	0.28 (7.11)	5.13 (130.3)	0.69 (17.53)	0.38 (9.65)	1.50 (38.1)

Dimensions (3-way/1 on pressure)															
Ordering Number	Connection Type	Orifice in. (mm)	A	B	C	D	D1	E	F	G	G1	H	M	N	Thickness
			in.(mm)												
SS-N60-S4-5	60S4	0.094 (2.39)	2.00 (50.8)	1.00 (25.4)	0.50 (12.7)	1.31 (33.27)		2.38 (60.45)	3.00 (76.2)	1.00 (25.4)	0.22 (5.59)	5.00 (127.0)	0.69 (17.53)	0.38 (9.65)	1.00 (25.4)
SS-N60-S6-5	60S6	0.125 (3.18)	2.00 (50.8)	1.00 (25.4)	0.53 (13.46)	1.31 (33.27)		2.62 (66.55)	3.00 (76.2)	1.00 (25.4)	0.22 (5.59)	5.25 (133.4)	0.69 (17.53)	0.38 (9.65)	1.00 (25.4)
SS-N60-S9-5	60S9	0.125 (3.18)	2.62 (66.55)	1.31 (33.27)	0.72 (18.29)	1.31 (33.27)		2.81 (71.37)	3.00 (76.2)	1.00 (25.4)	0.28 (7.11)	5.44 (138.2)	0.69 (17.53)	0.38 (9.65)	1.50 (38.1)

Dimensions (3-way/2 stem manifold)															
Ordering Number	Connection Type	Orifice in. (mm)	A	B	C	D	D1	E	F	G	G1	H	M	N	Thickness
			in.(mm)												
SS-N60-S4-6	60S4	0.094 (2.39)	2.00 (50.8)	1.00 (25.4)	0.50 (12.7)	1.72 (43.69)	1.31 (33.27)	3.44 (87.38)	3.00 (76.2)	1.00 (25.4)	0.22 (5.59)	6.07 (154.2)	0.69 (17.53)	0.38 (9.65)	1.00 (25.4)
SS-N60-S6-6	60S6	0.125 (3.18)	2.00 (50.8)	1.00 (25.4)	0.53 (13.46)	1.88 (47.75)	1.31 (33.27)	3.75 (95.25)	3.00 (76.2)	1.00 (25.4)	0.22 (5.59)	6.37 (161.8)	0.69 (17.53)	0.38 (9.65)	1.00 (25.4)
SS-N60-S9-6	60S9	0.125 (3.18)	2.62 (66.55)	1.31 (33.27)	0.72 (18.29)	2.06 (52.32)	1.31 (33.27)	4.12 (104.7)	3.00 (76.2)	1.00 (25.4)	0.28 (7.11)	6.37 (161.8)	0.69 (17.53)	0.38 (9.65)	1.50 (38.1)

- Note:
1. G is the drill dimension of packing gland mounting hole.
 2. G1 is the dimension of bracket mounting hole.
 3. Panel mounting drill size: 0.25 all valves.
 4. H is the dimension of stem in closed position.
 5. All dimensions are for reference only and are subject to change. For dimensions not shown above, please contact the authorized representative or FINELOK.