

# Excess Flow Valves

## EF Series

### Introduction

Applied to industry use. If downstream line ruptures, the excess flow valve can stop uncontrolled release of system media. When system works normally, the working element remains in the open position by spring. If the excess flow occurs downstream, the working element quickly moves to the tripped position to stop bleeding. When system pressure reaches balance through the bleed vent, the spring can reset the working element to the open position automatically. The flow which through bleed vent should be lower than one percent of the flow rate in the trip range.

### Features

- ☆ Compact design for convenient installation
- ☆ Maximum working pressure: 6000 psig (414 bar)
- ☆ Working temperature: -10°F to 400°F (-23°C to 204°C)
- ☆ Variety of end connections
- ☆ Stainless steel construction
- ☆ Leak-tight performance testing for every valve with nitrogen at the maximum working pressure



**End Connection:**  
tube fitting, thread or face sealed

- ☆ Easy installation
- ☆ Improved system reliability

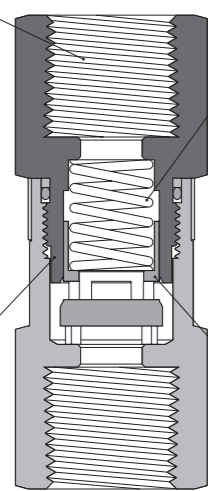

**Spring Drive to Brake**

- ☆ Easy operation
- ☆ Enabled to work in any direction and improve the safety of system

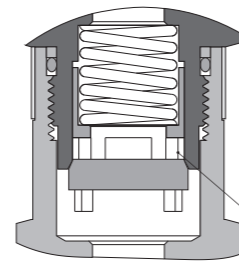

**Bleed Vent**

- ☆ Eliminate complicated by-pass mechanism
- ☆ Spring resets the element automatically

**All Metal Seat**

- ☆ Enhanced durability
- ☆ No maintenance needed

**Working Element**

- ☆ Improved capability and reliability
- ☆ High flow capability
- ☆ Nuisance tripping eliminated

### Temperature Ranges for Different Seal Materials

O-ring Material	Temperature Ranges °F (°C)
Buna N	-40 to 250 (-40 to 121)
Ethylene Propylene	-50 to 300 (-45 to 148)
Fluorocarbon FKM	-10 to 400 (-23 to 204)
Kalrez	-10 to 527 (-23 to 275)
Neoprene	-40 to 250 (-40 to 121)

### Flow Data at 70°F (20°C)

Orifice Size: 0.19 in. (4.8 mm)

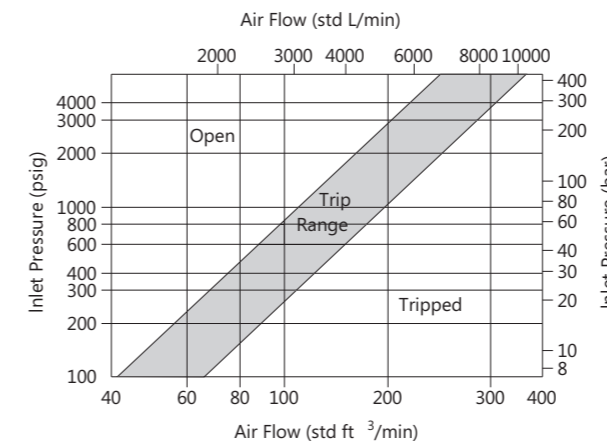

Orifice Size: 0.33 in. (8.4mm)

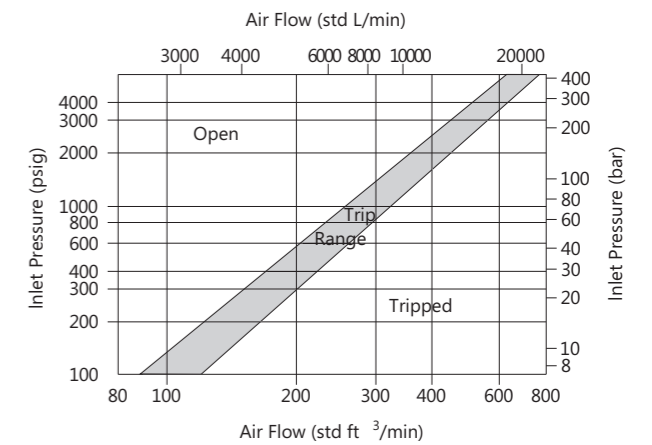

Orifice Size: 0.39 in. (10 mm)

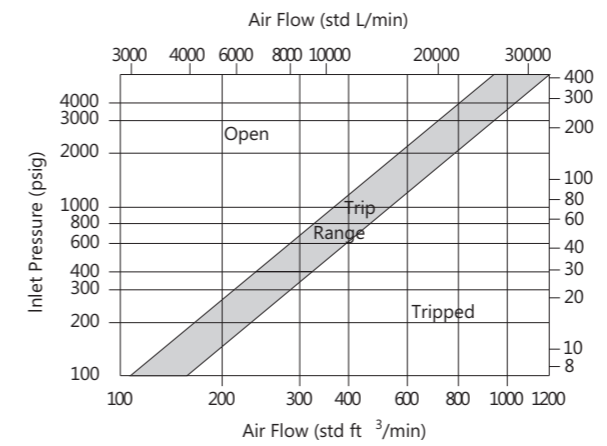

### Water Flow

Orifice in. (mm)	Trip Range Std ft³/min (L/min)
0.19 (4.8)	0.52 to 0.77 (14.7 to 21.9)
0.33 (8.4)	1.09 to 1.34 (31.0 to 37.8)
0.39 (10)	1.50 to 2.00 (42.3 to 56.3)

### Standard Materials of Construction

Component	Material Grade/ASTM Specification
1 Inlet Body	316 SS/A479
2 Mark Ring	6061 Al/B491
3 Working Element	316 SS/A479
4 Spring	302 SS/A313
5 O-ring	Fluorocarbon FKM
6 Seal Ring	PTFE/D1710
7 Outlet Body	316 SS/A479

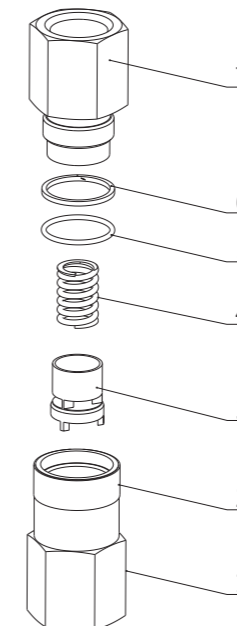

## Dimensions

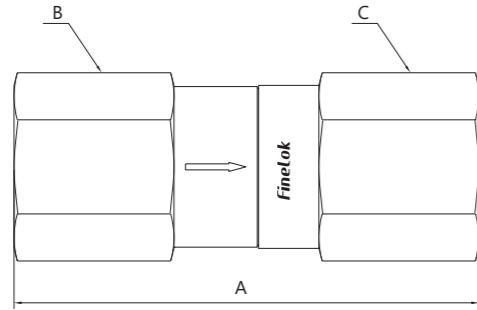

Basic Ordering Number	Connections Type and Size		Orifice in. (mm)	Dimension, in. (mm)		
	Inlet	Outlet		A	B	C
-EF-S4-4	1/4" FINELOK	1/4" FINELOK	0.19 (4.8)	2.43 (61.7)	11/16 (17.46)	11/16 (17.46)
-EF-S6-6	3/8" FINELOK	3/8" FINELOK	0.33 (8.4)	2.75 (69.9)	1 (25.4)	1 (25.4)
-EF-S8-8	1/2" FINELOK	1/2" FINELOK	0.39 (10)	2.64 (75.4)		
-EF-SM6-4	6 mm FINELOK	6 mm FINELOK	0.19 (4.8)	2.43 (61.7)	11/16 (17.46)	11/16 (17.46)
-EF-SM8-6	8 mm FINELOK	8 mm FINELOK	0.33 (8.4)	2.70 (68.6)	1 (25.4)	1 (25.4)
-EF-SM10-6	10 mm FINELOK	10 mm FINELOK		2.80 (71.1)		
-EF-SM12-8	12 mm FINELOK	12 mm FINELOK	0.39 (10)	2.96 (75.2)		
-EF-FNT2-4	1/8 Female NPT	1/8 Female NPT	0.19 (4.8)	1.87 (47.5)	11/16 (17.46)	11/16 (17.46)
-EF-FNT4-4	1/4 Female NPT	1/4 Female NPT		2.12 (53.8)		
-EF-FNT6-6	3/8 Female NPT	3/8 Female NPT	0.33 (8.4)	2.55 (64.8)	1 (25.4)	1 (25.4)
-EF-FNT8-8	1/2 Female NPT	1/2 Female NPT	0.39 (10)	3.03 (77.0)	1 1/16 (26.99)	1 1/16 (26.99)
-EF-NT2-4	1/8 Male NPT	1/8 Male NPT	0.19 (4.8)	1.79 (45.5)	11/16 (17.46)	11/16 (17.46)
-EF-NT4-4	1/4 Male NPT	1/4 Male NPT		2.17 (55.1)		
-EF-NT6-6	3/8 Male NPT	3/8 Male NPT	0.33 (8.4)	2.36 (59.9)	1 (25.4)	1 (25.4)
-EF-NT8-8	1/2 Male NPT	1/2 Male NPT	0.39 (10)	2.73 (69.3)		
-EF-NT4-S4-4	1/4 Male NPT	1/4" FINELOK	0.19 (4.8)	2.30 (58.4)	11/16 (17.46)	11/16 (17.46)
-EF-NT6-S6-6	3/8 Male NPT	3/8" FINELOK	0.33 (8.4)	2.56 (65.0)	1 (25.4)	1 (25.4)
-EF-NT8-S8-8	1/2 Male NPT	1/2" FINELOK	0.39 (10)	2.85 (72.4)		
-EF-NT4-FNT4-4	1/4 Male NPT	1/4 Female NPT	0.19 (4.8)	2.13 (54.1)	11/16 (17.46)	11/16 (17.46)
-EF-NT6-FNT6-6	3/8 Male NPT	3/8 Female NPT	0.33 (8.4)	2.46 (62.5)	1 (25.4)	1 (25.4)
-EF-NT8-FNT8-8	1/2 Male NPT	1/2 Female NPT	0.39 (10)	2.89 (73.4)		1 1/16 (26.99)

1. FINELOK means FINELOK double ferrule tube fittings.
2. Sizes and types listed are standard. Other sizes and types are available upon request.
3. Dimensions are shown with FINELOK nuts finger-tightened. All dimensions are for reference only and are subject to change. For dimensions not shown above, please contact the authorized representative or FINELOK.

## Ordering Information

