



"T" BUCKET FRAME & CHASSIS

Chassis shown (#21464) Stage 4 with coil-overs and rear end upgrade



MORE CHOICES FOR YOU

You have more options with CCR's chassis. They are offered in four stages. Stage 1 is the bare frame; Stage 2 is the bare frame with all the mounting brackets that need to be welded, welded in place. Stages 3 and 4 give you many of the chassis components, including complete front-ends and rear-end housing (stage 4), and steering, brake, and suspension options.

STAGE 1

Stage 1 is the 103" wheel based "T" (14" bed) bucket frame, completely jig welded. It's the best foundation you can build your "T" on top of.

21102 • Bare Frame \$479.95

21105 • Frame w/front perch \$529.95

STAGE 2

Stage 2 gives you the frame and all mounting brackets jig welded in place. Your chassis will be set up for the motor, transmission and rear-end you will be using. Specify the standard or long body.

21222 • Stage 2 for rear spring \$929.95

21224 • Stage 2 for coil-overs \$969.95

21226 • Stage 2 for Jag Rear-end \$1150.95

• Power Brake brkts. Upgrade, add \$39.00

STAGE 3

The Stage 3 chassis is designed to give you a great start on your chassis at an affordable price. It includes the stage II chassis as well as many other parts to get you started on your complete chassis, including the side mounts for mounting the motor, the transmission dropout for setting up your trans., and the front axle and spindles for mounting your brakes and tires. Just add the rest of the parts as they are needed.

21352 • Stage 3 with rear spring . \$2750.00

21354 • Stage 3 with coil-overs . . \$2850.00

21356 • Stage 3 setup for Jag \$2895.00

• Power Brake brkts. Upgrade add \$39.00

STAGE 4

The Stage 4 "T" bucket chassis is our most complete chassis. With our Stage 4 chassis you just need front brakes, wheels and tires and you're rolling. It contains everything listed in the chassis parts list to the right, and is the best start for your car.

21462 • Stage 4 w/ rear spring ... \$3895.00

21464 • Stage 4 w/ coil-overs \$4095.00

21466 • Stage 4 set up for Jag ... \$3795.00

No Third Member included in price.

• Power Brake Brakes add \$210.00

• Assy. Charge for Will Call \$250.00

(For Stage 3 or 4 chassis)

CHROME PACKAGES

FOR STAGE 3 AND STAGE 4 CHASSIS

You can get your Stage 3 and Stage 4 chassis in chrome. It contains all of the parts on the chassis list marked with a star (★) beautifully chromed to give your car a show quality finish.

Stage 3 Chrome Package add \$2150.00

Stage 4 Chrome Package add \$2350.00

*** Shipping not included in prices. Chassis and frames must be shipped disassembled by truck. Allow 3-5 weeks for chassis build. Allow 2-4 weeks for delivery (an additional 2-3 weeks for chrome).**

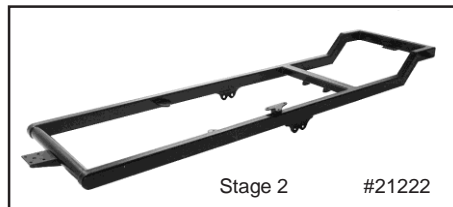

Hours: T-F 9-5 PST • Sat 9-12 • Closed Sundays and Mondays
909-393-4005 • 909-627-1188 fax

Building Street Rods Since 1971

www.californiacustomroadsters.com



"T" BUCKET CHASSIS PARTS LIST



"T" BUCKET FRAME AND CHASSIS

California Custom Roadsters, Inc., commonly known as CCR, is committed to offering the best chassis and component parts for your street rod. For over 30 years we have been building "T" bucket chassis for the street rod enthusiast. Although all "T" chassis have similar looks and functions, there are many differences in design, quality, and strength. A close look at the details reveals the commitment we have to being the best.

CCR's chassis is completely heli-arc welded in our precision jig. The frame is much more durable than most; built from 2" x 3" x 3/16" (.1875") tubing instead of the usual 1-1/2" x 3" x 1/8" (.125) used by others. The larger tubing means your chassis will be stronger—great if you use a big block. Also, your chassis will look nicer because the corners of the larger tubing have nice round edges instead of skinny, square edges found on smaller tubing. This is important because a lot of your chassis is exposed. All of the chassis brackets are made to blend into the chassis, not just welded on top, or on the side. For example, the front perch mounts under the frame, not over, so the front of your car shows the beautiful paint job. The radius rod brackets mount under the frame, not on the side, once again for great appearance. The tie rod runs behind the axle—not way out in front—and the drag link runs parallel to the radius rods instead of crisscrossing them. The front of your "T," which is completely exposed, has a

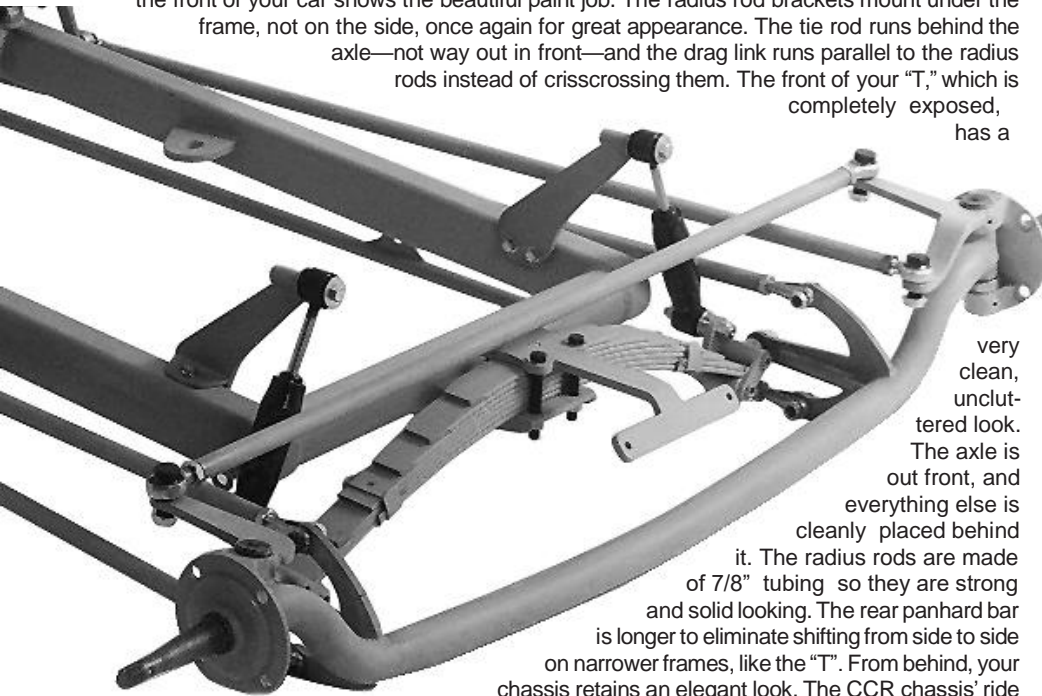

very clean, uncluttered look.

The axle is out front, and everything else is cleanly placed behind it. The radius rods are made of 7/8" tubing so they are strong and solid looking. The rear panhard bar is longer to eliminate shifting from side to side on narrower frames, like the "T". From behind, your chassis retains an elegant look. The CCR chassis' ride is complemented by not only the front spring but a pair of shocks as well.

For a great look and ride, the CCR chassis is your best choice.



COMPARE THE DIFFERENCES IN A CCR CHASSIS



WHAT DO YOU GET WITH IT?

These are the parts that come with a coil-over chassis, other setups will come with their respective pieces.

STAGE 1

- Frame (specify standard or long body)
- Front Spring Perch

STAGE 2

- Motor Mount Frame Bracket
- Steering Box Mount
- Radius Rod Hangers
- Transmission Cross-member
- Master Cylinder Bracket
- Rear Upper Coil-Over Mounts
- Panhard Bar Mounts
- Shock Tower (weld-on)
- Brake tabs

STAGE 3

- ✱ Front Perch w/Bolt Kit
- ✱ Front Multi-Leaf Spring
- ✱ Front Shackle Hangers
- ✱ Front Shackles
- ✱ Front Tube Axle w/Spring Hangers
- ✱ Custom Spindles w/King Pins installed
- ✱ Tie Rod w/ends
- ✱ Front Radius Rods w/ends
- ✱ Side Mounts w/biscuit set
- ✱ Drop-Out Transmission Mount
- ✱ Rear Radius Rods w/ends
- ✱ Rear Radius Rod Hangers
- ✱ Coil-Over Shocks
- ✱ Lower Coil-Over Bracket
- ✱ Coil-Over Bolt Kit
- ✱ Panhard Bar w/Bolt Kit
- ✱ Panhard Bar Rearend Bracket

STAGE 4

- ✱ Reversed Corvair Steering Box w/Arm
- ✱ Drag Link w/ends
- ✱ Rear Axle Housing
- ✱ Lower Front Shock Mount
- ✱ Front Shocks
- ✱ Front Shock Mounting Bolts
- ✱ Front Shock Studs
- ✱ Master Cylinder
- ✱ Brake Pedal Assembly

✱ Indicates items that are available in chrome.

Get a complete list of parts for a chassis set up for a transverse spring and rear shocks or Jag rear-end by calling or emailing CCR.



Hours: T-F 9-5 PST • Sat 9-12 • Closed Sundays and Mondays
909-393-4005 • 909-627-1188 fax

www.californiacustomroadsters.com

Building Street Rods Since 1971





"T" BUCKETBODIES

1915 "T" BUCKET BODY

CCR's 1915 "T" bucket body is available as a special order only. Please allow 5-7 weeks before delivery. It comes with a flat dashboard and front lower part of body notched to fit wider frames. The floorboard, turtle deck, and all beds must be trimmed to fit. Length 49", body width 43", firewall width 24", height at back 29", at door lines 17", and at firewall 17".

81101 • 1915 "T" Bucket Body .(special order only). \$895.00

Please Note: The 1915 body will need some trimming in the floor and firewall area in order to fit on our chassis. Also, the drop-in interior kit is not made for this body, but can be custom made for \$225 more than the standard interior.

INNOVATIVE DESIGN—ONE PIECE BODY WITH FLOOR

For the ultimate in strength, appearance, and design, we have reengineered our popular 1923 "T" bucket and smooth "T" bodies. When you order the bodies with the floorboard installed, you will get our all new, one-piece, cored floor design. The body and floor are one piece. The underside of the body is clean and smooth, rounding seamlessly into the body. The finish on all of our bodies is so clean that it requires very little prep work for paint. All floors are 3" up from the bottom of the bodies. For the best looking, strongest—and easiest—"T" body, choose CCR!

1923 "T" BUCKET BODY

CCR's 1923 "T" bucket & Smooth "T" bodies are the finest fiberglass "T" bodies available. The bodies are sturdy enough to use without wood reinforcement. They have a custom dash & firewall, and you can get CCR's popular drop-in interior kit for it. You have your choice of turtle deck, 14", or 20" pick-up bed. The pick-up beds are made to fit the bodies perfectly, & easily bolt on. There's no need for fiberglass or resin reinforcing.

81104 • 1923 "T" Body (with floorboard—one-piece) \$1350.00

81156 • 1923 "T" Body (with floor & 14" bed installed) \$1750.00

81158 • 1923 "T" Body (with floor & 20" bed installed) \$1750.00

81160 • 1923 "T" Body (with floor & turtle deck installed) \$N/A

81105 • 1923 "T" Body (with floor & functioning door) \$1950.00

1923 EXTENDED "T" BUCKET BODY

The Limousine of "T" Bodies—Stretched 8 Inches

If you need your space, CCR has what you're looking for—our Smooth "T" body is a full 8" longer than standard "T" bodies. It is 5 inches longer in the passenger area and 3 inches in the cowl. All door and body lines have been removed to keep you in style with the clean, smooth look of today's show-winning street rods. The Smooth "T" body comes with our new one-piece, cored floor, just like the standard 1923 body, so there are no rough edges underneath—completely smooth top to bottom.

81114 • 1923 Smooth "T" (with floorboard—one-piece) \$1650.00

81168 • 1923 Smooth "T" Body (w/floor & 20" bed) \$1995.00

81170 • 1923 Smooth "T" Body (with floor & sport deck) \$2275.00

Add \$85.00 for boxing charge on any body

NOTE: All bodies must be shipped by truck; call for estimate of shipping cost.

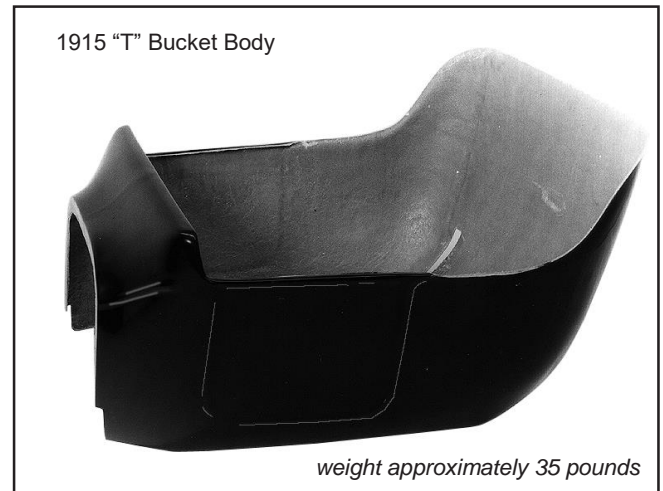

Hours: T-F 9-5 PST • Sat 9-12 • Closed Sundays and Mondays
909-393-4005 • 909-627-1188 fax

Building Street Rods Since 1971

www.californiacustomroadsters.com



"T" PICK-UP BEDS



"T" BUCKET BODY DIMENSIONS

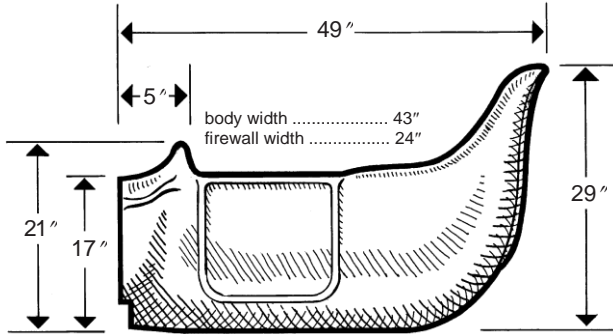

1915 "T" Bucket Body

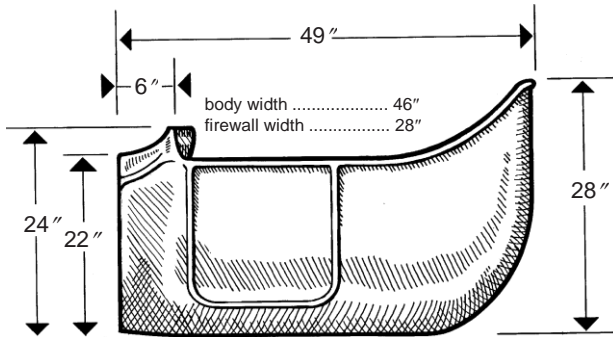

1923 "T" Bucket Body

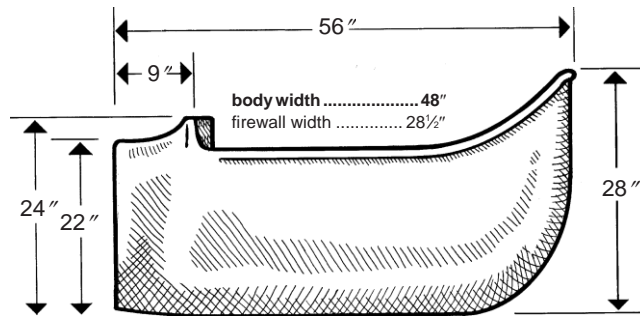

1923 Smooth "T" Body

Standard "T" Pick-Up Beds



14" Pick-Up Bed

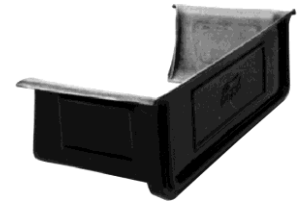

20" Standard Bed

PICK-UP BEDS FOR STANDARD "T" BODY

CCR's pick-up beds are all manufactured with the floor molded in, as one piece. All beds for our standard body have body lines on the sides. The 14" pick-up bed has a Ford script tailgate. The 20" beds are available with a Ford script tailgate or a smooth recess for the license plate.

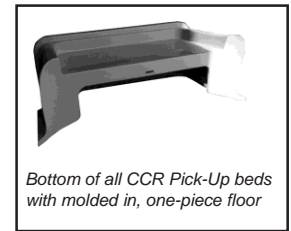

Bottom of all CCR Pick-Up beds with molded in, one-piece floor

The tailgates are molded in—to eliminate extra body work, and to provide superior strength and stability. W:42", H:15 1/2", weight: approx. 20#. Beds can be shipped by UPS (oversized).

81024F • 14" Standard Pick-Up Bed w/Ford script tail \$299.95

81026 • 20" Standard Pick-Up Bed w/recess tailgate \$299.95

81026F • 20" Standard Pick-Up Bed w/Ford script \$299.95

Add \$20.00 for boxing charge on any bed

Smooth "T" Pick-Up Bed



Bed for Smooth "T" body shown with Recess Tailgate

PICK-UP BEDS FOR SMOOTH "T" BODY

CCR's Smooth pick-up beds also have the floor molded in—as one piece—like our standard "T" beds. The beds for the Smooth "T" body have smooth sides to match the body. You may choose the Ford script tailgate or the smooth license recess. The tailgates are molded in to eliminate extra body work, and to provide superior strength and stability. The Smooth "T" Beds are 20" deep. can be shipped UPS (oversized).

81025 • 20" Smooth Pick-Up Bed w/recess tailgate \$299.95

81025F • 20" Smooth Pick-Up Bed w/Ford script tailgate . \$299.95

Add \$20.00 for boxing charge on any bed

TAILGATES ONLY

81032 • Standard Tailgate w/Ford script \$89.95

81034 • Smooth Tailgate w/license recess \$89.95



Hours: T-F 9-5 PST • Sat 9-12 • Closed Sundays and Mondays
909-393-4005 • 909-627-1188 fax

www.californiacustomroadsters.com

Building Street Rods Since 1971





"T" BODY WITH DOOR

"T" BODY WITH OPENING DOOR

The world's best "T" bucket body is now available with a door.

California Custom Roadsters, Inc., has finally manufactured a "T" bucket body with a functional passenger side door. This door is complete with hidden hinges, door latches, bumpers and a full tube steel support structure. To ensure quality, the new door body is only available as an assembled unit (body with floor and door). The choice of beds, or turtle deck, is still up to you as separate pieces to allow for any combination.

Up until late 1992 when California Custom Roadsters introduced the first "one-piece body and cored floorboard," there was not a proper way to support a door and door jam without major inner structure on the body and door. The strength of the one-piece unit allowed CCR to build the finest "T" bucket body, with a functional passenger side door for ease of entry and exit.

The door jam in the body is designed for maximum strength even without the steel tube body brace. The body brace not only stiffens the body but also serves as a solid mounting point for the door catch and seat riser. A separate steel tube brace attaches the windshield/dash area to the body side and into your frame through the cored laminated floorboard of the CCR body, while also serving as a mounting point for the pair of hidden hinges that allow a full 90 degree of swing.

The door itself shows how dedicated we are to providing the best product possible—the mounting points for the hinges are backed by 1/4" steel plate, the door latch and hinges mount flush with the inner door skin, which is bonded to the outer door skin in the mold to keep tolerance tight. There are even rubber door bumpers set into the door to eliminate any rattles or movement and to keep the glossy black gelcoat finish perfect even before painting. (Note: door kit is not sold separately).

If you are even thinking about purchasing a "T" bucket body, you owe it to yourself to check out our bodies. There really is no other body being built that compares in construction, looks or quality to any of our "T" bodies.

81105 • "T" Body w/opening door \$1950.00

(Complete with floor, functioning door, door supports, hinges, and door latch installed)

81120 • Smooth "T" Body w/door \$2250.00

Add \$85.00 for boxing charge on any body

NOTE: All bodies must be shipped by truck; call for estimate of shipping cost.

Now Available!

Smooth "T" Long Body with Opening Door

#81120 \$2250.00



Standard "T" Body with Opening Door

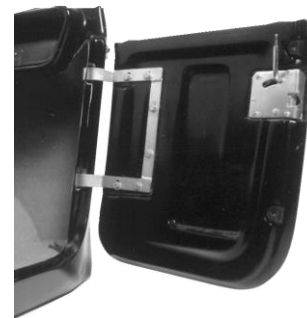

"T" BUCKET BEDS TO FINISH OFF YOUR BODY—IT'S YOUR CHOICE

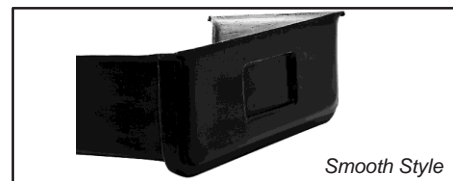

Smooth Style



Traditional Look

All of CCR's "T" bucket ↑ beds now have the same Super strong "one-piece with floorboard" design as our bodies.



CCR's Turtle Deck →

You can get CCR's 20" beds in either smooth style (a recess for license plate) or traditional look (Ford script).



Hours: T-F 9-5 PST • Sat 9-12 • Closed Sundays and Mondays
909-393-4005 • 909-627-1188 fax

Building Street Rods Since 1971

www.californiacustomroadsters.com



rev:12.04.18