



# SAFETY / TUG / MINI TUG INSTALLATION MANUAL

232



**WARNING:** To ensure the longevity of your system, reading and following these instructions is necessary. Make sure to follow the recommended maintenance intervals found on page 14.



## HORNBLASTERS SHOCKER 2-GALLON KIT CONTENTS

- Air Compressor (3Q)
- HornBlasters 2-Gallon Air Tank
- HornBlasters Air Horn (Varies)
- 17' 1/2" Airline
- Air Filter Relocation Kit (in compressor box)
- Ear Plugs
- Air line Cutter
- HornBlasters Universal Wiring Kit
- PS-150H Pressure Switch

### Identifying Fittings

The diameter of the thread (X) will indicate what size thread a fitting has. If you're not sure which fittings are 1/2", 3/8", or 1/4", measure the thread on each fitting and match it up with the values below.

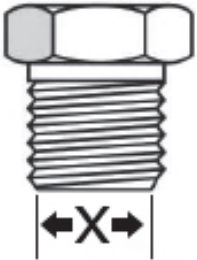

1/2" NPT  
0.84"

3/8" NPT  
0.675"

1/4" NPT  
0.54"

1/8" NPT  
0.405"



1x  
Safety Blowoff Valve



1x  
1/2" PTC  
Fitting



1x  
Drain Cock Fitting



1x  
Reducer Bushing



1x  
Air Gauge

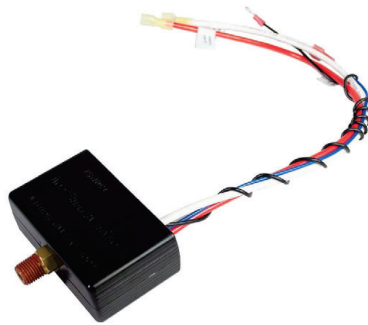

1x  
Pressure Switch



1x  
Universal Wiring Kit



## Safety Tips and Important Information

### IMPORTANT SAFETY INSTRUCTIONS



#### **Caution: To prevent the risk of electric shock or electrocution:**

- Do not disassemble any electrical components of this horn kit (air compressor, air valve, pressure switch).
- Do not attempt repairs or modifications of any component. Please refer to qualified service agencies for all service and repairs.
- Do not operate any component where it can fall or be submerged into water or any kind of liquid.
- Do not reach for any component that has fallen or been submerged into water or any kind of liquid.
- Use the included components with 12 volt DC systems only.
- Do not leave the air system unattended during use.

#### **WARNING: To prevent injury:**

- Never allow children to operate the compressor or air horn. Use close supervision when operating this equipment near children or animals.
- The air compressor will become very HOT during and immediately after operation. Do not touch any part of the compressor with your bare hands during or immediately after use.
- Do not use this product near open flames or explosive materials or where aerosol products are being used.
- Do not operate this product where oxygen is being administered.
- Do not pump anything other than atmospheric air.
- Never use this product while sleepy or drowsy.
- Do not use any tools or attachments with the supplied air source unit without first determining maximum air pressure for that tool or attachment.
- Never point any air nozzle or air sprayer toward another person or any part of your body.
- The included compressor is equipped with an automatic reset thermal protector and can automatically restart after the thermal protector resets. Always cut off power source when thermal protector becomes activated.
- Use only in well ventilated areas.
- Do not sound the air horn(s) in close proximity to another person's or your own ear(s).
- Do not fill the included air tank above 150 PSI. Doing so may result in death or serious injury.
- Disconnect the battery negative cable before doing anything. Failure to disconnect this terminal can lead to damaged electrical components.
- Use eye protection when operating drills or other power tools during the install.
- Ensure the parking brake is engaged before you get underneath the vehicle.
- Do not wire the system without the fuse holder.
- Do not allow the compressor to run when the vehicle is off.



## Recommended Tools + Addons

### Recommended Tools

- Wire Stripper / Crimp Tool
- 10mm Socket/Wrench
- Adjustable Wrench for brass fittings
- Drill (10mm bit)

### Compatible Add-on Kits *(available @ [www.HornBlasters.com](http://www.HornBlasters.com))*

Name	Description	Part #
Tire Inflation Kit	Adds a quick disconnect to your system which allows you to use air tools with our kit.	AA-TIK-H
Electric Drain Valve Kit	Replaces the drain cock with a solenoid valve; allows for remote draining of the system	AM-D04K
Digital Air Gauge	2' Digital Air Pressure Gauge allows you to monitor the tank pressure in the cab	GA-220H
Compressor Mounting Bracket	L-shaped mounting bracket for your compressor	CP-BRACKET-H
Dual Compressor Upgrade	2nd Compressor add-on for your kit - Cuts fill time in half	DCU-3Q

### Optional Install Items *(Not required but will make your install easier)*

- **Fuse Tap** - Great for tapping into a key-power source like the cigarette lighter from your fuse-box.
- **Self-Tapping Screw** - These can be used for ground points on the pressure switch, compressor, and valve.
- **Slotted Angle Iron** - Can be used to mount the horns without making a plate.
- **Cable Ties** - Used to keep your air line looking clean and organized.
- **Heat Shrink Tubing** - Can be used over the terminal connectors to better seal them up against the elements.
- **1" Adjustable Wrench** - Makes it easier to get the brass fittings into the tank. You can use one wrench for all the fittings on the system.
- **PTFE Thread Sealant** - Can be used instead of Teflon to seal fittings.

## Preparing For the Install (continued)



### Recommended Install Locations for Trucks (Compressor)

- The toolbox is a great location for the compressor. Do not use the toolbox as a ground point as it will not be directly connected to the frame of the vehicle.
  - Mounting the compressor/tank underneath the bed is a great option. There's plenty of room available and mounting the compressor outside will help it run cooler and save space in your bed / toolbox.
  - The engine bay is a good spot for the compressor as long as you keep it away from the exhaust manifold and engine block. The engine generates a lot of heat and will keep the compressor from running cool. If the compressor overheats, it will not run until it has cooled off.
- \*Keep in mind that the air tank has to be close to the compressor. The leader hose on the compressor is 18" long.**

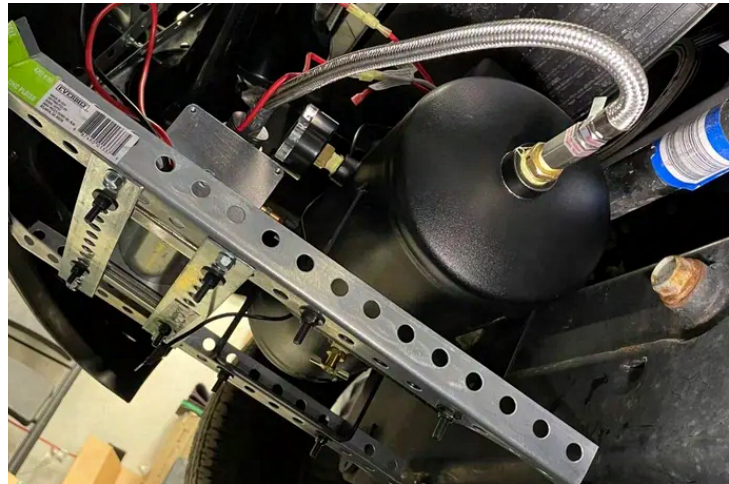

### Recommended Install Locations (Horns)

- You can mount these horns underneath the bed as shown below.
- If you face the horns forward when mounted underneath they may pickup some dirt/dust from the road. This is normal and will not damage the horn. We suggest using a blowgun to remove excess dirt/dust bell semi-annually.





## Preparing the Air Compressor

Start by locating the hardware that was packaged with your air compressor. You should have a set of mounting bolts, two barb fittings, and an air filter housing. A picture of each is shown to the left for reference.



Barb Fittings  
(Male & Female)

Let's start by taking the fitting on the left with the male thread and inserting it into the compressor inlet. The other fitting (female end) can be threaded onto the filter housing directly. Your compressor/filter should look like the image below. At this point, you can use the supplied air line that was packaged with the compressor to connect the compressor and filter together.

**\*This line is not meant to hold pressure. Do not use this for anything other than the filter.**



Filter Housing



Relocation Air Line

Connect fittings to  
compressor & filter



Route 3/8" air line in  
between filter/compressor

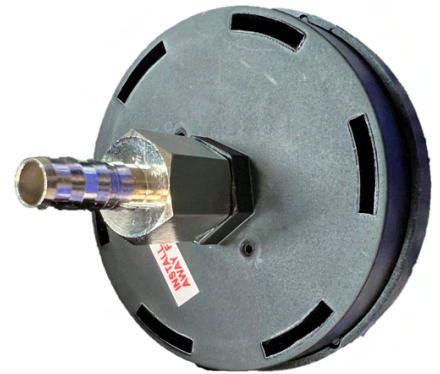

## Filter Placement

Your compressor is fully sealed against the elements. If the compressor is mounted outside with the air filter on the end of the compressor, the filter will get wet and water will get pulled into the compressor. To prevent this, the filter must be relocated to an **ENCLOSED AND DRY** location. If your compressor is mounted in the bed of your truck or underneath the bed, the filter could be relocated into the cab of the vehicle. The filter must be relocated to an area where it will not be exposed to debris or moisture.

**If the air filter is not relocated, the compressor will pull in water/dirt and will stop working properly. 9 out of 10 compressors that fail within the first year have pulled in water/debris from the intake.**

**WE DO NOT WARRANTY COMPRESSORS THAT HAVE FAILED DUE TO WATER/DEBRIS BEING PULLED INTO THE INTAKE/FILTER**

Route the air filter up into the bed as shown to the right. This will ensure the compressor **ALWAYS** pulls dry clean air. If you cannot route the filter into the bed, route it somewhere high and dry. **DO NOT JUST LET IT HANG OFF THE COMPRESSOR.**



## Preparing the Air Compressor (continued)

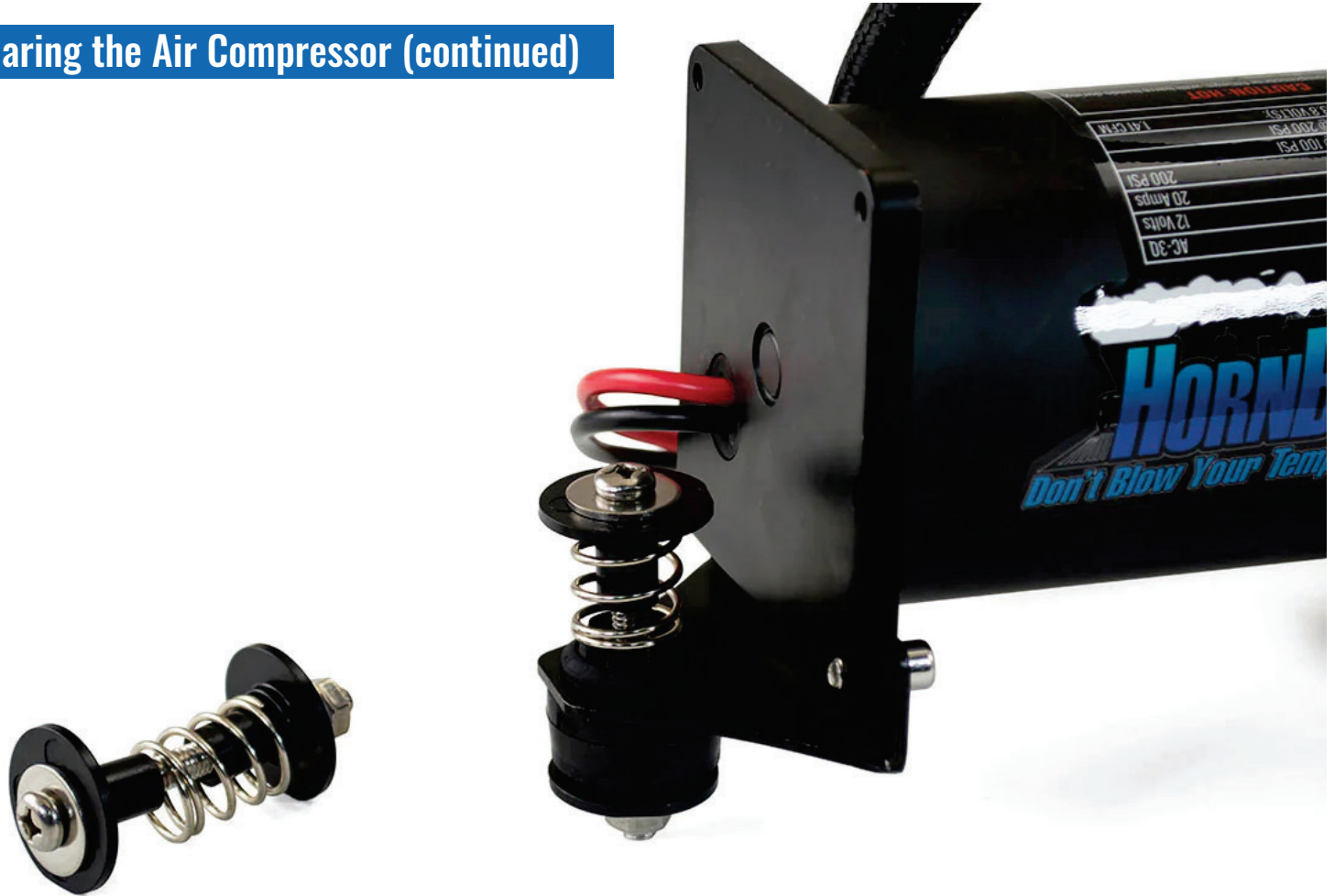

The 3Q air compressor features a pair of 3 feet with a spring-loaded rubber mount to reduce the vibration from the compressor while it fills the tank. The feet must be assembled as shown above for the right fit. Do not over tighten these! Finger tight + 1/2 turn is plenty.

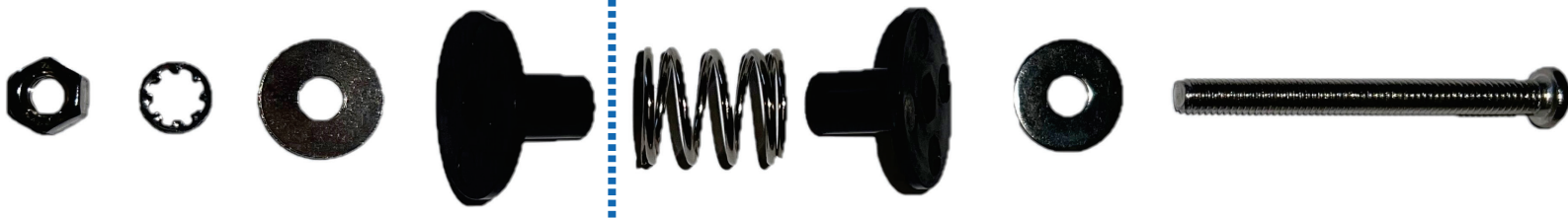

Each foot will use the hardware as shown above. Use a Phillips head screwdriver and a 10mm wrench/socket to tighten each foot. Remember, hand tight + 1/2 turn. If you over-tighten the assembly these feet will transfer all of the compressor vibration directly to your vehicle. The dotted blue line in the assembly above is where the rubber part of the foot will be when you assemble the hardware together. The plastic cup that faces towards the bolt will go on the bottom of the rubber along with the nut/washers.

## Recommended Tank Assembly



\*Always make sure the drain cock is facing DOWN. Regardless of how you decide to assemble the tank, the drain fitting needs to point down to allow water to drain. Gravity will pull water to the bottom of the tank.

### Option 1



### Option 2







## Plumbing the Compressor Into the Tank

Once you have assembled and mounted both the tank & compressor, plumb the compressor into the tank. The compressor's braided hose will thread into the reducer bushing that we plumbed into the end-cap of the tank, (on the right hand side of the tank in the photos on page 8).

The photo to the right shows the check valve plumbed into the reducer bushing.

It is extremely important that you **do not over-tighten this piece**. Over-tightening this piece can lead to the compressor not filling the tank.

Use a small amount (2-3 wraps) of teflon on this fitting. If teflon won't seal well, we recommend Loctite 545.

The check valve needs to be torqued to 12-14 ft lbs. Screw this piece in hand-tight and give it another 1/4" turn with a wrench.

It helps if you tighten the reducer bushing into the tank all the way first, that way the reducer isn't spinning with the check valve.



## Plumbing the Air Valve to the Tank

Now that the compressor's plumbed into the tank, let's get the horns connected. Locate the roll of 1/2" air line that was supplied with your kit. Make sure both ends are cut straight/flush. If one end is not cut straight, the line will not make a proper seal in the fitting. Once the line is cut, go ahead and push the line into the fitting on the end of the tank. The line will simply push into the fitting and lock into place.

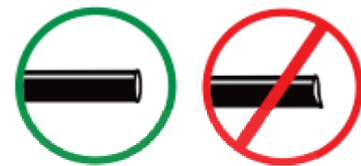

GOOD CUT POOR CUT

Be careful not to bend the airline right out of the fitting. This can cause the fitting to leak over time. Take a larger bend further away from the fitting to prevent the line from stretching the fitting out.

These fittings can be re-used with the same line multiple times. If you need to remove the line, follow these steps:

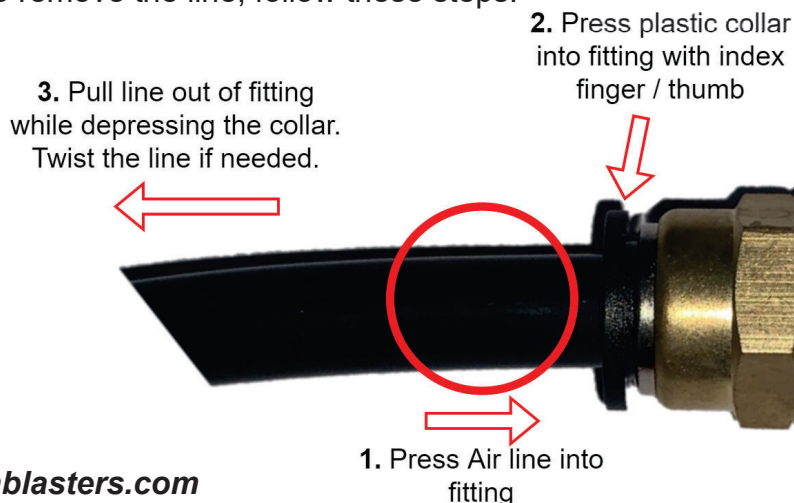
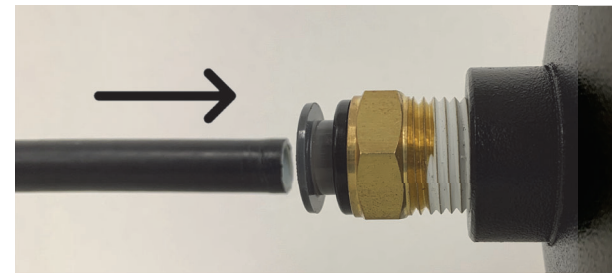

## Plumbing the Horn to the Tank

The horn side will connect differently from the tank side. The valve on the horn uses a compression fitting.

Get started by using an adjustable wrench to remove the nut from the compression fitting.

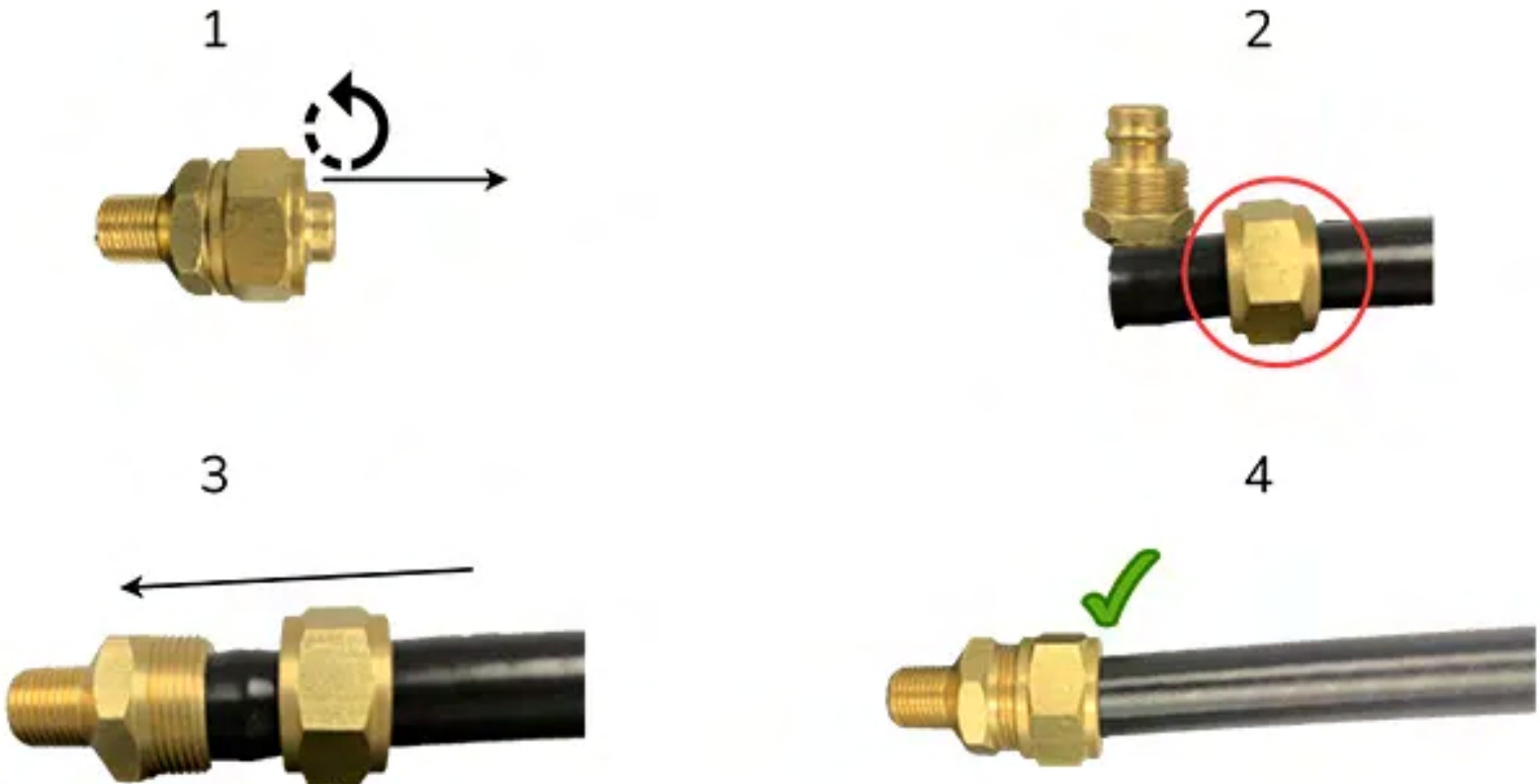

**Bad Cut**

**Good Cut**



Ensure each air line is fully seated over the compression fitting before tightening the nut down over it. If the line is not fully seated over the barb, it can slip off the fitting even with the nut in place. Firmly hold the line in place and use a wrench to tighten the compression ferrule down. The line will not seal properly if you don't hold it down in place while tightening the nut. It will slip off!

The horn will sound very weak if the line isn't seated properly. If the line is too stiff, you can heat it up to make it more malleable. Don't over-do it on the heat as it will melt at a certain point.

**\*Take note of the air line to the left. If the line is not cut flush, it will not seal and will create a leak directly out of the tank.**

## Wiring the Compressor (150H)

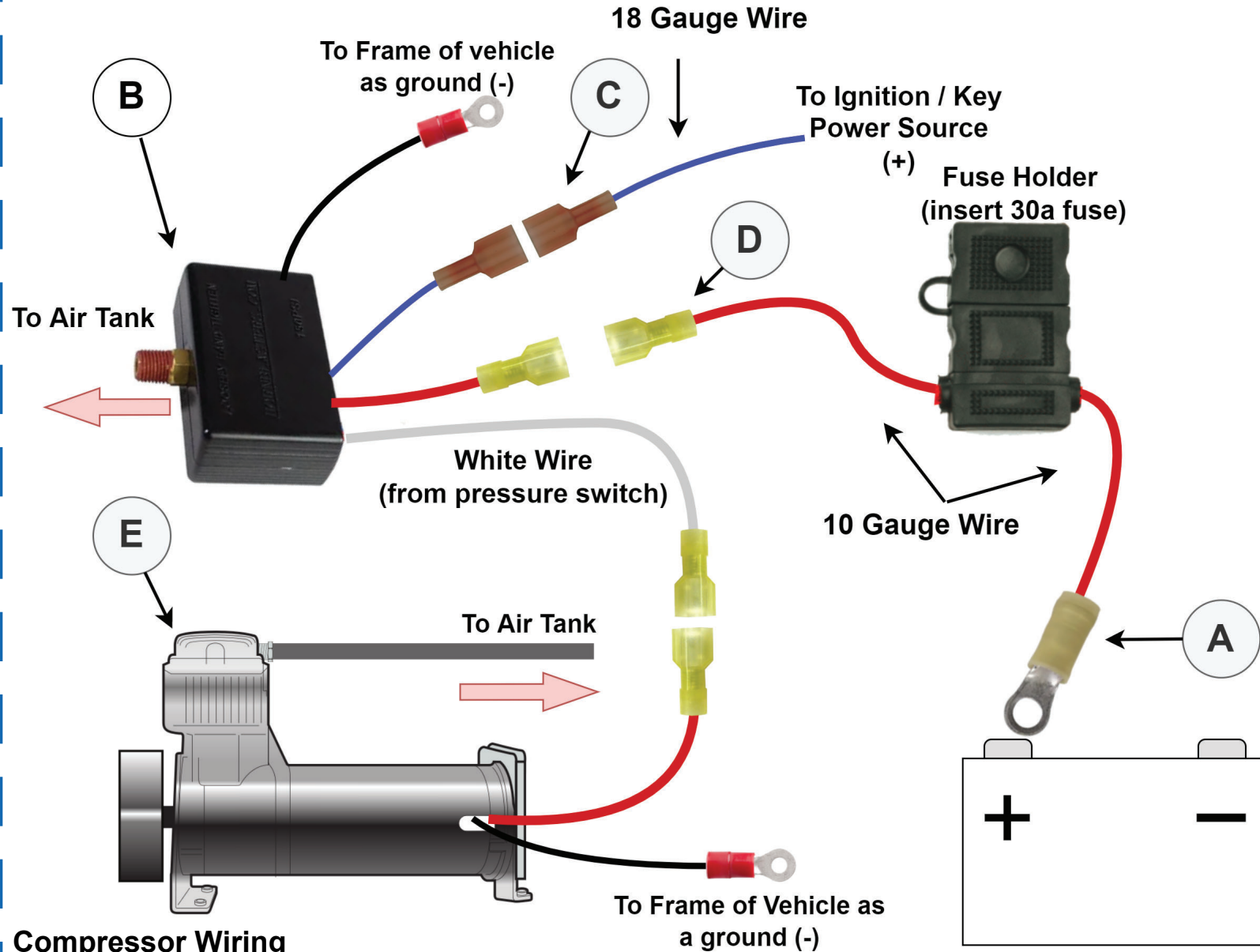

### Compressor Wiring

A = 10 GAUGE TAN RING TERMINAL

B = PRESSURE SWITCH

C = 18 GAUGE RED MALE SPADE CONNECTOR

D = 10 GAUGE YELLOW/GREEN FEMALE SPADE CONNECTOR

E = AIR COMPRESSOR

An **ignition/key power source** can be any circuit that is hot when the vehicle is on. Good examples of these are the radio, daytime running lights, power seats, cigarette lighter, or even an accessory fuse. You can use the included T-tap or Scotchlok connector to tap onto one of these circuits

Alternatively, an add-a-fuse can be sourced separately and be used to pull key-power from the fuse box. The cigarette lighter fuse is almost always key-power on, as well as any fuses for power outlets throughout the vehicle. If the compressor runs when the vehicle is off, your power source is hot all the time.

Make sure to run the supplied 10-gauge red wire from the fuse holder up to the pressure switch's red wire. You can use the supplied 18-gauge wire for the key-power connection. (blue wire)



## Maintenance / Tips (Do not throw this away!)

### Once every...

#### • 2 Weeks

- Drain the air tank of moisture! Do not let the water build-up in the tank longer than 2 weeks. The water can find it's way into your horns and cause them to sound squeaky or not at all. The water can also find it's way into your pressure switch and cause it to fail.

#### • Month

- Check the air filter element for the compressor. If the element is showing signs of dust/dirt build-up, replace it with a new one.

#### • 2 Months

- Check your air lines and make sure they're not rubbing against anything. Inspect the horns for damage.
- Check your wiring for corrosion (**especially in the winter time**) If the terminal connectors become oxidized or corroded, the kit could stop working at random in the future.

#### • 3 Months

- Replace the filter if you haven't already. Inspect the filter if it was recently replaced.
- Check the tank for leaks. After being installed on your vehicle for some time, the vibration from daily use can cause a small leak to occur at the fittings or air line connections. Spray down with Windex or soapy water to find the leak point.

#### • Year

- Check your ground connections. If the connection to the frame isn't that good or comes loose, the compressor or solenoid valve will stop working properly.
  - Use a wire brush to clean these up if needed.
- Inspect your mounting hardware for the compressor/tank/horns. Ensure all components are still secured nice and tight.



Drain Cock  
Closed Position



Drain Cock  
Open Position



Use a flathead screwdriver to pry the filter housing apart. You can insert the flat end of the screwdriver into seam, where the arrow is.

Remove the old filter element from the housing. Insert the new element into the center so that the white portion of the filter lines up with the plastic tabs. Replace the cover back over the housing, lining the tabs up on the sides of the cover.



## Troubleshooting

### Compressor

- **The compressor doesn't turn on.**
  - Try connecting the compressor to a 12v battery directly.
    - Take the red wire to the positive terminal and the black wire to the negative terminal.
    - Give us a call if the compressor doesn't run. If it does, go to the next step.
  - Double check the blue wire on the pressure switch.
    - If this blue wire is not hooked up or doesn't have +12v power, the compressor will never run.! This blue wire receives a signal from the car to let the system know the car is on. This is to prevent the system from running when the car is off.
  - Make sure the fuse isn't blown
    - If the fuse is blown, this could be due to a short in your wiring. Before you put a new one in,! check and ensure your wire is not frayed or exposed anywhere.
- **The compressor doesn't fill the tank**
  - Make sure the drain cock isn't open
    - Refer to page 14. If the drain is open, the tank is not sealed and cannot pressurize.
  - Make sure the valve isn't open or backward
    - If the valve is open, the air from the compressor is escaping through it constantly. If the valve! is backward, air will escape through it constantly.
  - Check the compressor's air inlet
    - If the plug from the inlet was not removed, the compressor cannot suck in air. Remove the! filter and remove the plug.
    - Make sure to check that you removed the plug from the end of the compressor's leader hose.! If the plug is still present, the compressor will not be able to push air out of the hose.
- **The tank loses pressure after a few hours**
  - Spray each fitting and air line with soapy water or Windex®.
    - The liquid will bubble up anywhere a leak is present. Typically, fittings need to be tightened! further or more Teflon tape needs to be applied to the thread. If you have a leak from the air! line connections, re-cut the lines flush and re-seat them into the PTC fittings.
  - Make sure the compressor's check valve wasn't overtightened
    - If the check valve is overtightened, it will leak back to the compressor and the air will escape! from the filter. **This may also lead to a blown fuse.**



## Troubleshooting

### Horns

- **The horns won't honk**

- Check the air tank for air pressure. If your air gauge reads 0 PSI, refer to the steps on page 15 to remedy the lack of air in the tank.
- Check the wiring for the horn solenoid valve. If the valve has a loose ground connection, it will not work properly. Make sure the valve is connected to your activation switch.
- Check the power source for the horn activation. Use a test light or voltmeter to check for +12v on the lead coming from your stock horn wire or power source. Make sure power is coming into and out of the activation switch/button.

- **The horns don't sound right**

- If your horns start to squeak or sound high-pitched, drain the tank. Moisture buildup in the tank is finding it's way from the tank into your horns. This causes them to squeak.
  - Drain the tank of moisture.
  - Make sure the horn isn't full of water - it will squeak if water is present in the bell. Give the horn a nice long honk to clear it out.
- Check and ensure the end of each bell isn't obstructed or blocked. The horns will sound off at a different pitch when the opening of the bell is blocked.

- **The horn honks on it's own as soon as it is wired up**

- This is a tricky problem to fix and can be confusing to most. On some vehicles, the stock horn receives a constant feed of power from the battery. When the wheel is pressed, a switch inside the steering wheel creates the ground for the horn circuit and the horn honks. When you wire your OEM horn wire to our valve, the valve ground completes the circuit and causes the constant honk.
  - We can fix this problem by following these steps:
    - Disconnect the valve ground from the frame.
    - Splice from the OEM horn NEGATIVE lead and route this to the toggle switch.
    - Connect the opposite lead of the toggle to the black wire on the valve.
  - This makes it so that the valve is actuated from the negative side of the OEM wiring. If you have trouble with this, give our team a call @ (877)-209-8179.
- Make sure the valve isn't connected to a constant power source. If the valve is receiving power constantly, it will stay open.

**Can't find your issue listed above? Give our team a call @  
(877)-209-8179 or shoot us an email to [sales@hornblasters.com](mailto:sales@hornblasters.com)**



**HORNBLASTERS**

*Don't Blow Your Temper, Blow Your Horns!*