



P.A. SYSTEM INSTALLATION MANUAL

100 Watt Public Address w/ Sirens



WARNING: To ensure the longevity of your system, reading and following these instructions are recommended.

PUBLIC ADDRESS SYSTEM INSTALLATION GUIDE

BEFORE GETTING STARTED

Read over the entire instruction guide before you begin your installation.

KIT CONTENTS:

- HornBlasters PA Control unit with microphone
- HornBlasters PA speaker
- Wiring Kit

IMPORTANT: This complete public address system uses 12 volt DC components. Only install this kit with a 12 volt DC power source.

IMPORTANT SAFETY INSTRUCTIONS

This document provides all the necessary information to allow your HornBlasters product to be properly and safely installed. Before beginning the installation and/or operation of your new product, the installation technician and operator must read this manual completely. Important information is contained herein that could prevent serious injury or damage.

- Proper installation of this product requires the installer to have a good understanding of automotive electronics, systems, and procedures.
- If mounting this product requires drilling holes, the installer must be sure that no vehicle components or other vital parts could be damaged by the drilling process. Check both sides of the mounting surface before drilling begins. Also de-burr any holes and remove any metal shards or remnants. Install grommets into all wire passage holes.
- Do not install this product or route any wires in the deployment area of your air bag. Equipment mounted or located in the air bag deployment area will damage or reduce the effectiveness of the air bag, or become a projectile that could cause serious personal injury or death. Refer to your vehicle owner's manual for the air bag deployment area. The User/Installer assumes full responsibility to determine proper mounting location, based on providing ultimate safety to all passengers inside the vehicle.
- For this product to operate at optimum efficiency, a good electrical connection to chassis ground must be made. The recommended procedure requires the product ground wire to be connected directly to the NEGATIVE (-) battery post.
- This product uses a remote device to activate or control the unit, make sure this control is located in an area that allows both the vehicle and the unit to be operated safely in any driving condition. **DO NOT ATTEMPT TO ACTIVATE OR CONTROL THIS DEVICE IN A HAZARDOUS DRIVING SITUATION.**
- It is recommended that these instructions be stored in a safe place and referred to when performing maintenance and/or reinstallation of this product.
- **FAILURE TO FOLLOW THESE SAFETY PRECAUTIONS AND INSTRUCTIONS COULD RESULT IN DAMAGE TO THE PRODUCT OR VEHICLE AND/OR SERIOUS INJURY TO YOU AND YOUR PASSENGERS!**

SAFETY DURING INSTALLATION

- Disconnect the ground of your battery before beginning your installation.
- Use eye protection when operating drills.
- Take your time and do not rush your installation.

INSTALLING YOUR PUBLIC ADDRESS SYSTEM

The HornBlasters PA-100H can be installed in many different types of vehicles. The guidelines for the installation of the product are written so that no matter what vehicle is being used, the installation and operation will be simple and straight forward.

SELECTING A MOUNTING LOCATION

The following guidelines will help you select a good location.

- The unit should be mounted on a metal surface to aid heat dissipation. Be sure that this surface is not one that either generates or is exposed to excessive heat during normal operation of the vehicle.
- Do not select a location where the unit will be exposed to potential damage from any unsecured or loose equipment in the vehicle.
- Be sure the area selected will not allow the unit to be exposed to water.
- When routing the wires, it is important to choose a path that will keep these wires away from excessive heat and from any vehicle equipment that could compromise the integrity of the wires (ex. trunk lids, door jams, etc.)
- When the best mounting location has been determined, securely fasten the unit to its mounting surface using the supplied hardware.

Caution: As it will be necessary to drill holes into the mounting surface, the installer **MUST** be sure that no vehicle components or other vital parts could be damaged by the drilling process. Check both sides of the mounting surface before drilling begins.

- Position the unit in its proposed mounting location to ensure that it fits properly. With the unit in place, insert an awl or other suitable tool into the mounting screw area of the unit and scribe the areas that are to be drilled.
- Remove the unit from its mounting area and using as appropriately sized drill bit, drill a hole in each of the areas scribed in the previous step.
- Return the unit to its mounting location and using the supplied screws, mount the unit onto its mounting surface.

Important

Disconnect the ground (Negative -) terminal from your battery until you are finished making all electrical connections.

WIRING YOUR PA

- Make sure all connections have a good contact and are secure. Use the provided quick-connect terminals or butt connectors to make connections between all wires.
- Make sure you have a good, clean ground. Clean all grime from the grounding location until you have bare metal or run a wire to the negative terminal on the battery to insure a clean ground.

ACCESSORY SWITCHES

IMPORTANT: We do not offer support on accessory switches and any accessories you attach to the PA system. Opening the PA control unit will void your warranty with HornBlasters.

- Your amplifier comes with two optional accessory switches that may be used to control other automotive accessories. These switches are optional to use.
- To power high-amp devices and to reduce risk of damage to your amplifier, use these switches each with a relay. You can use a 4-pin relay to facilitate toggling an accessory on and off, or a 5-pin relay to switch between two accessories (e.g. between a high pitch air horn and a train horn). To do this, please refer to the high-amp diagram on page 4.
- When wiring the switches, the inputs may be negative or positive. The output will be the same as the input per switch. (e.g. Attach 'Accessory 2 Input' to positive: when the second toggle switch is turned on (1), 'Accessory 2 Output' will be a positive; when it is off (0) the output will be dead/not connected).

WIRING DIAGRAM

IMPORTANT: Disconnect the ground (Negative -) terminal from your battery until you are finished making all electrical connections.

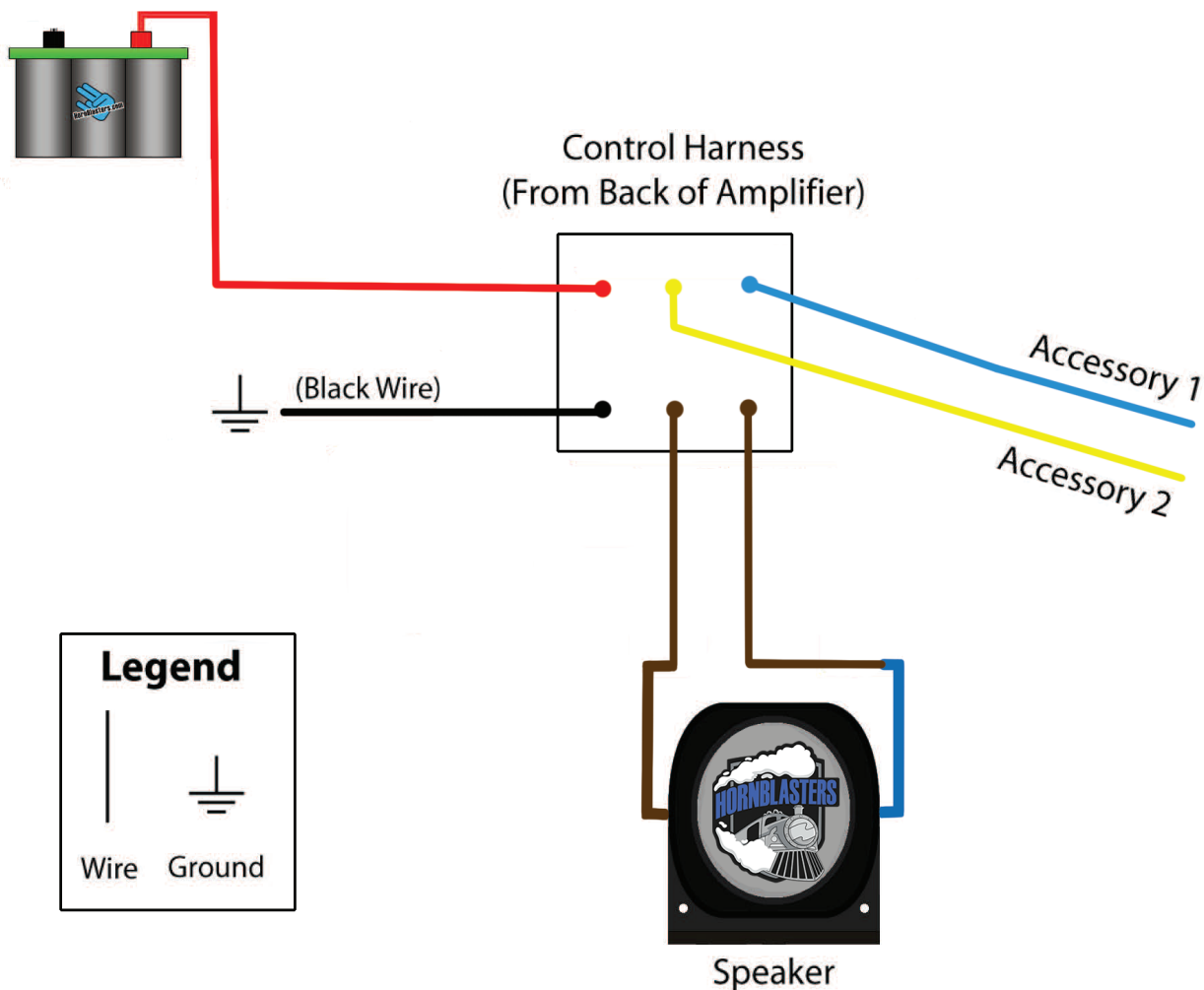

- The control harness in the diagram is a representation of the harness at the back of the amplifier.
- The yellow and blue wires, may be used to wire up accessories. Please refer to the 'Accessory Switches' section in the manual on page 2.
- Although the amplifier contains 3 fuses (one for the input power, and one for each of the accessory switches) we recommend installing an inline fuse from the battery. This will make the connections safer against fire and also make maintenance easier.
- If your accessories will draw less than 8 amps each, you may use the diagram above. If your accessories pull more than 8 amps then follow the wiring diagram on page 4.
- The speaker wires (brown) may be reversed. This will reverse the speaker phase and should make no apparent difference to the listener. Ignore the fact that the speaker has red and black wires.

Having trouble? Call us today at 877.209.8179.

FINISHING UP

Once you have finished your installation, make sure the gain of your amplifier is turned to the 'off' position, the accessory switches are in the off (0) positions, fuses are inserted into any fuse block you installed, and finally to reconnect the ground terminal of your battery.

TESTING YOUR INSTALLATION

Before using your public address and siren system, you should test the work you've done.

1. Make sure every electrical connection is solid and that there are no loose wires. A loose wire could create an electrical fire, blow a fuse, or cause other havoc in your vehicle.
2. Verify that the speaker and amplifier are mounted securely. They must be able to withstand jerks, vibrations, and any other shock that your vehicle exposes them too. If either does not feel secure, remount it and secure the unit safely before continuing.

Read the usage instructions below carefully before using your public address system

USING YOUR PA-100H SYSTEM

Before using your Public Address & Siren system, please make sure you have read this entire instruction manual. Always make sure that no person or animal is close to the system speaker when it is in use. You and anyone close to the device should always use hearing protection. Failure to do so may lead to permanent injury. Use safety at all times.

USING YOUR PUBLIC ADDRESS SYSTEM

1. Turn the function dial to 'radio' on the front of your amplifier.
2. Turn the gain up on your amplifier (must be to an audible level)
3. Press and hold the button the side of the mic while speaking into it.

USING THE AIR HORN SOUND & SIRENS

You must be authorized to use the emergency sirens and sound effects. Please check with the local, state, and federal law enforcement agencies before sounding a siren or using the air horn sound.

USING THE AIR HORN SOUND

The air horn sound is a distinctive emergency air horn tone. You may use this sound while the amplifier is in any function mode.

1. Make sure the gain is turned up on your amplifier (must be to an audible level).
2. Push up the air-horn/manual siren paddle to the air horn label. The amplifier will play the sound as long as you hold the paddle up.

USING THE AUTOMATIC SIRENS

The automatic siren functions will sound a siren repeatedly until the amplifier is turned off or function dial is turned back to 'radio'.

1. Make sure the gain is turned up on your amplifier (must be to an audible level).
2. Turn the function dial to any of the siren options: Manual, Wail, Yelp, Yelp-1 or Hi-lo. Your amplifier should begin to play the selected siren automatically until it is turned off.

USING THE MANUAL SIREN

The manual siren may be used to override any of the automatic sirens, or while using the 'radio' function to play the siren for a brief amount of time.

1. Make sure the gain is turned up on your amplifier (must be to an audible level).
2. While using any of the functions, push the air horn/manual siren paddle down to the manual siren label. The amplifier will play the manual siren for a short period of time. You may interrupt it by turning your amplifier off, pushing the talk button on the mic (while in 'radio' function), or using the air horn sound effect momentarily.

Having trouble? Call us today at 877.209.8179.

MAINTENANCE & TIPS

GENERAL PUBLIC ADDRESS SYSTEM MAINTENANCE

- Make sure all wired connections are secure and making good contact.
- Periodically check to make sure that your speaker is free from dirt and debris.

TIPS

- Make sure your engine is running when your public address is in use to insure proper voltage proper

TROUBLESHOOTING

Problem	Possible Cause(s)	Corrective Action
Public address system does not turn on when gain is turned up. (Light should light up on control panel)	<ol style="list-style-type: none"> 1. Fuse is blown. 2. Bad electrical connections. 3. Light has burnt out. (Unlikely) 	<ol style="list-style-type: none"> 1. Check all electrical connections. When okay, replace fuse. 2. Make sure your negative and positive connections are good. 3. Replace light and confirm the PA is receiving power.
No sound is being output from the speaker. (The amplifier is receiving power and light turns on when gain is turned up)	<ol style="list-style-type: none"> 1. The gain turned up. 2. The speaker is not connected properly. 3. You are not using the mic correctly while on the 'radio' function, and are not using a siren function. 	<ol style="list-style-type: none"> 1. In order to hear anything from the speaker, the gain must be turned up to an audible level. 2. Make sure one brown wire is connected to the brown wire on the speaker, and the other to the blue wire on the speaker. 3. You must depress the mic button firmly while speaking to produce sound. Otherwise, you may turn the function dial to anything other than 'radio'.
Accessory switches do not do anything.	<ol style="list-style-type: none"> 1. These switches only function if you add the additional wiring circuits as described in the wiring diagram. You have not made these yet. 2. Blown fuse. 3. Bad electrical connections. 	<ol style="list-style-type: none"> 1. You may wire either a positive or negative connection to the accessory input and then use the output to provide power to your accessory. (You do not have to wire both switches). 2. You must open your amplifier and replace the internal fuse. 3. Check connection with a multi-meter to insure everything is hooked up correctly.

CAN'T FIGURE IT OUT?

No problem! Give us a call at 877-209-8179, or email at sales@hornblasters.com and we'll be more than happy to help you fix your system. Also feel free to visit our online train horn community, www.TrainHornForums.com, for more information.

No problem! Give us a call at 877-209-8179, or email at sales@hornblasters.com and we'll be more than happy to help you fix your system. Also feel free to visit our online train horn community, www.TrainHornForum.com, for more information.

Having Trouble? Call us today! +1 (877) 209-8179