



## HornBlasters Dixie Electric Horn Install Guide

Thank you for your purchase! Your new Dixie air horn is the perfect addition to give your vehicle that iconic flair. Versatile in installation, this horn is commonly mounted behind the front bumper/grille, with the compressor neatly positioned around the crash bar – a setup suitable for almost any vehicle.

Your Dixie horn package includes a 40A relay, the dedicated Dixie Horn Compressor, the Dixie horns, 7 feet of air line, and a comprehensive set of mounting hardware. As you prepare for installation, here are some important considerations to keep in mind:

- 🔊 The compressor for these horns will draw ~28 amps under load. Make sure to use **10AWG wire or larger!**
- 🔊 Each air line from the compressor to the bells must be the same length, otherwise the tune will not sound off correctly.
- 🔊 The 40A relay must be used. If you connect this compressor directly to your stock horn wires, it can blow the horn fuse and could cause irreversible damage to your vehicle. Mount the compressor upright so that the air outlets face upward. Mounting the compressor upright will minimize the wear on the internal components.
- 🔊 18-Gauge wire can be used for the trigger connections on the relay (pins 85/86)

The Dixie horn can be used with either the steering wheel or a separate push button. If your vehicle has auxiliary switches installed, these can be used as well.

### Mounting Each Horn Bell

Each horn can be mounted to your vehicle using one of the plastic tabs along with a nut and bolt from the hardware bag. Start by locating one of the nuts, bolts, and plastic tabs for the horn. Insert the bolt through the mounting tab and use a nut to secure the tab for the bolt. Leave room in-between the plastic tab and head of the bolt.



Locate one of the horn bells. The head of the bolt will slide into the base of the horn as shown below. Make sure the alignment tab for the plastic mount is lined up with the slot on the horn as circled below. At this point, the horn is ready to be mounted. Once your mounting hole is drilled, remove the nut from the bolt and insert the bolt through the mounting hole. Re-thread

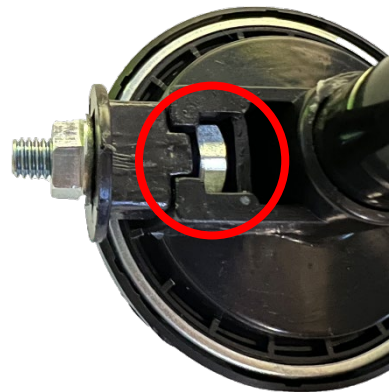

the nut on the bolt and tighten it down. Don't over-tighten it or the plastic will break. You will repeat this process for all five horn bells.

### Mounting the Compressor

The compressor is mounted similarly to the horn bells. In the hardware bag, there is a bolt/nut that is bigger than the rest. This is used to mount the compressor. Slide the bolt into the mounting tab on the compressor. Locate the square-shaped rubber block that was packed with the hardware. You can use this in between the compressor mounting tab and your mounting surface to prevent noise from vibration. Use the included nut to secure the compressor to the desired install location. Once mounted, locate the roll of air line that came with the horns.





## Running the Lines

Locate the farthest bell from the compressor. Since all the lines need to be the same length, each line will need to match the length of the line that runs from the compressor to the farthest bell. You may have to coil the line up for the closest bell to keep it organized. If you find that the included hose is not long enough for your application, this line is vinyl tubing and the size is 8mm ID.

## Wiring the Compressor

The Dixie can be wired to operate off your steering wheel, a separate push button, or your auxiliary switch(es). Each method requires the use of our 40A relay, even if your auxiliary switch has a relay.

### Push Button Method

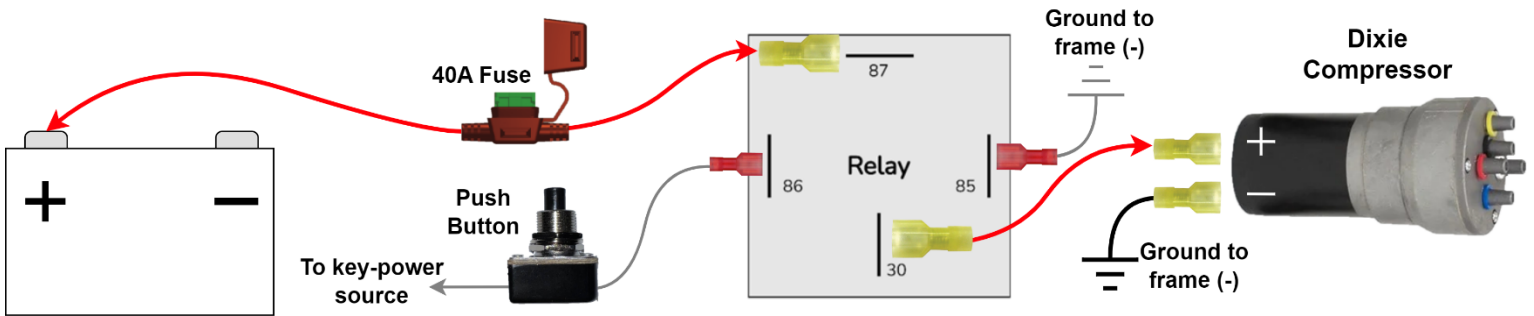

Start by cutting the fuse holder in half to make two ends. Connect one end to the battery. Use a butt connector on the opposite end to run 10-gauge wire to pin 87 on the relay. You will also use a section of 18-gauge wire from the end of the fuse holder to the push button. Use the red 10-gauge (larger) wire from pin 30 to the compressor, as well as for the compressor ground. Use 18-gauge (smaller) wire from the push button to pin 86, and from pin 85 to the desired ground point.

### Steering Wheel Method

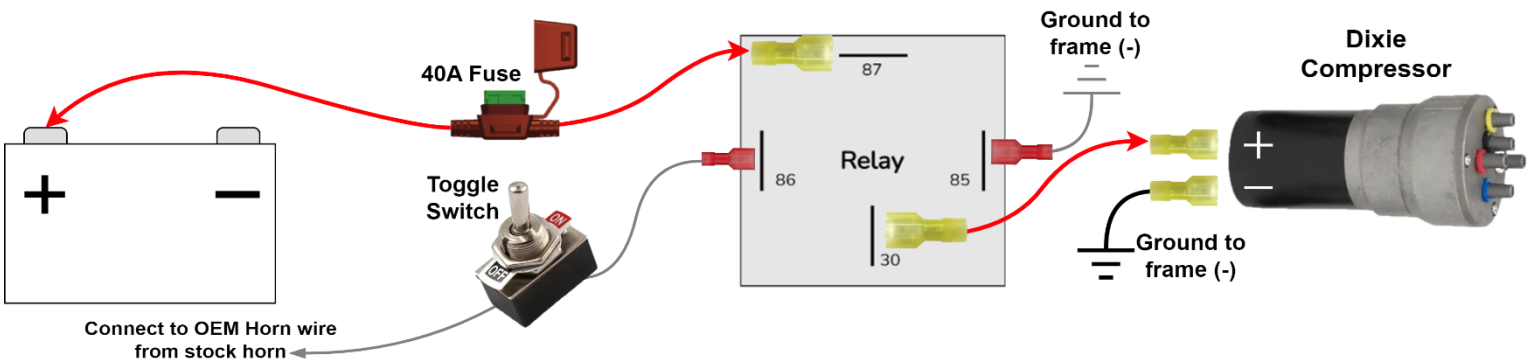

The easiest way to do this is to locate the stock horn in the front grille or fender well. Locate the two-wire connector going into the horn. One of these two wires is the positive lead. You can use a test light to probe each portion of the horn connector. Press the steering wheel to determine which of the two wires is positive. Keep in mind that when you press the wheel, the stock horn will go off with the Dixie horn. This method works best if you plan to replace the OEM horn with the Dixie entirely. A detailed guide is available on our website that goes over locating the OEM horn wire. Scan the QR code to the right of this paragraph for instant access.

At this point, you're ready to make some noise. Test the horn! If you have any questions or need help with the install, give our team a call @ (877)-209-8179.

