

PUMPS



Owners Manual



⚠ WARNING

This equipment must be installed and serviced by a qualified technician. Improper installation can create electrical hazards which could result in property damage, serious injury or death. Improper installation will void the warranty.



Notice to Installer

This manual contains important information about the installation, operation and safe use of this product. Once the product has been installed **this manual must be given to the owner/ operator of this equipment.**

Table of Contents

LOCATION	01
INSTALLATION	01
ELECTRICAL CONNECTION	02
THREE PHASE MOTOR	02
WIRING DIAGRAM	02
PRIMING	03
MAINTENANCE	04
FLUID TEMPERATURE	04
SERVICING	04
GENERAL SAFETY RULES	05
WARNINGS FOR INSTALLATION AND ASSEMBLY TASKE	06
WARNINGS FOR ASSEMBLY AND MAINTENANCE TASKE	06
TROUBLESHOOTING	07

LOCATION

The pump must be located as close as practical to the pool. The pump must also be in a position that enables easy access for periodic servicing.

Care must also be taken to position the pump in an area that is free from flooding in a well ventilated and dry area.

INSTALLATION

Waterco Limited use the latest technology when designing and manufacturing our pumps, a few simple precautions during installation will ensure years of trouble free operation.

1. The pump suction line should be not smaller than 1 1/2" (40mm imperial) or 50mm true metric.
2. The suction line is to have as few bends or elbows as possible. There must not be an air trap on the suction line.
3. Use only the pump barrel unions supplied with the pump.
4. Bolt the pump to the required position (prevent movement).
5. The pump electrical cable must be wired for the proper voltage and rotation in accordance with the wiring instructions.
6. All wiring (electrical) work must be carried out by licensed electricians and must be installed in accordance to the local codes.
7. The motor must be grounded.
8. The weight of the plumbing and fittings is to be independently supported and not carried by the pump.

~ **IMPORTANT ELECTRICAL NOTICE** ~

The electrical installation is to be done by a licensed electrician.

Each pump requires a circuit breaker to separate the pump from the electrical supply.

The contact separation has to provide full disconnection in all poles under overvoltage category III conditions.

*If the pump is to be installed on a swimming pool or pond situation it is **MANDATORY** that an earth leakage circuit breaker with a rated tripping current not exceeding **30mA** be installed.*

Check the pumps name plate for the following: Voltage, Amp draw and Cycle.

*The power cord, including the ground wire shall have a quality of **245 IEC66 (H07RN-F)** for models **greater than 1Kw** power input.*

*For models less than **1Kw** input the quality shall be of **245 IEC57 (H05RN-F)**.*

*All installations must comply with local codes, based on **IEC 364-7-702** requirements.*

• RESPECT THE MINIMUM GAUGE GIVEN IN THE CHART OF THE TECHNICAL MANUAL.

ELECTRICAL CONNECTION

Check that the information on the nameplate corresponds to the power supply.

Employ a competent electrician to ensure wiring installation is made in accordance with any local electrical codes. Every motor requires either a **fused disconnect switch or a circuit breaker**.

A SINGLE PHASE MOTOR has a built in thermal overload switch.

THREE PHASE MOTOR

THREE PHASE MOTORS requires a starter switch or magnetic starter with correctly sized overload protection in addition to the fused disconnect switch.

CHECK THE ROTATION OF THREE PHASE MOTORS.

The motor is only suitable for clockwise operation when viewed from the motor end fan (cowl) cover.

Three phase motors could rotate in either direction. Changing any 2 wires of the cable on a three phase motor will reverse the direction of rotation. To check the rotation of the motor, turn on for approximately 1 second. If it is running in the wrong direction turn off power and interchanging any 2 wires and repeat the above step to check.

When installing three phase pumps a separate device must be available for permanent installation, this is so the pump can be isolated from the mains power. **A contact distance of 3mm per pole is required for both three phase and single phase units.**

Motor protection **MUST** be installed corresponding to the nominal current of the motor. **SEE VALUE ON RATING PLATE.**

It is the **RESPONSIBILITY** of the user to ensure adequate protection between the motor and the power supply.

The installer must protect all three phases on the supply of the motor so that the pump cannot run on 1 or 2 phases only.

⚠ WARNING

Before disconnecting electrical connections, shut of the electricity at its source:

EXAMPLE : The fuse or circuit breaker box. Before work is carried out on the pump ensure the pump switch or timers are turned off and **MAKE CERTAIN THE MAINS POWER IS SWITCHED OFF.**

WIRING DIAGRAM

• SINGLE PHASE



• THREE PHASE



• ROTATION OF 3 PHASE PUMP

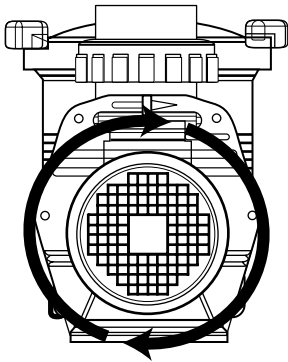

CLOCKWISE ROTATION

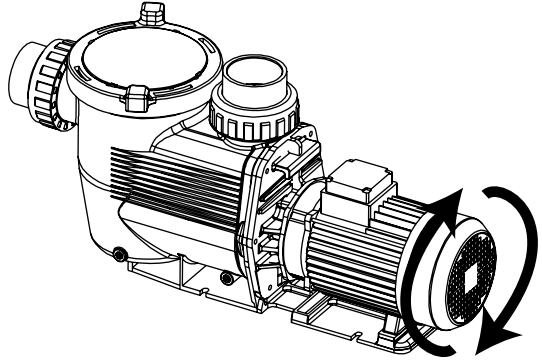

PRIMING

The Waterco Limited pump will prime and re prime providing the hair and lint pot bowl is full of water and there is sufficient supply from the suction point.

If you lose water from the hair and lint pot bowl it will be necessary to re fill it before starting.

1. Remove the clear lid and fill the hair and lint pot bowl with water.
2. Replace the lid ensuring **the o-ring is correctly** located and start the pump.

After you have done this allow a **few minutes (maximum)** for the pump to start delivering water.

⚠ WARNING

High suction lift or long suction lines will require additional time to prime and can severely affect the performance of the pump. If the pump will not prime, (flow) repeat step 1 and 2 above.

⚠ WARNING

Mechanical seals if allowed to run dry can be damaged rapidly and may need to be replaced.

ENSURE that there is always adequate water in the hair and lint pot bowl before you commence start up.

If you are unable to prime the pump please see the trouble-shooting guide.

*Ensure all **suction and discharge** valves are open before you start the pump, operating the pump with these valves shut can damage the pump.*

MAINTENANCE

The strainer basket in the hair and lint pot bowl should be inspected and cleaned at **regular intervals**.

1. Remove lid and lift out basket.
2. Remove debris and hose off with clean water if necessary.
3. Inspect the lid gasket, lubricate with **SILICON** based grease only if needed.
If it is damaged replace.
4. Replace the strainer.
5. Re-prime the hair and lint pot bowl.
6. Correctly locate the o-ring.
7. Replace the lid (**hand tighten**) only.
8. Switch on pump.

In Climates where the pump may be **exposed to frost or freezing**, care must be taken to ensure the pump is protected from damage.

It is recommended that if the pump is not used during this winter period it should be **drained completely**.

Waterco Limited supply drain plugs for this purpose.

Do not replace the drain plug. Store it in a safe place until you require the use of the pump.
An example would be within the hair and lint pot bowl basket.

If at all possible remove the pump away and store it in a dry location during this period.

When you re activate the pump ensure all seals and o-rings are in operational condition, re-grease if necessary (**replace**) if unsure of condition.

- *Check that the motor shaft moves freely before re-activation.*

FLUID TEMPERATURE

The permissible temperature is **> than 0°C and < than 35°C**. The pump should never be operated outside of these temperatures or damage may occur.

SERVICING

If the need arises or you are unable to service your Waterco Limited pump always contact your **authorized Waterco Limited Service agent** for advise or infield service.

- *Always use genuine Waterco Limited replacement parts when carrying out pump maintenance.*

GENERAL SAFETY RULES

1. The machines mentioned in the manual are specially designed for the pre-filtering and re-circulation of water in swimming pools.
2. They are designed to work with clean water at a temperature not exceeding **35 degrees Celsius (95 degrees Fahrenheit)**.
3. The installation should be carried out in accordance to the safety instructions of swimming pools, **especially Standard HD 384.7.702**, and the specific instructions for each facility.
4. The rules enforce on accident prevention should be carefully followed.
5. Any modification of the pump requires the **prior consent of the manufacturer**. Original replacement parts and accessories authorized by the manufacturer ensure a high level of safety. The manufacturer of the pump assumes no liability for the damage and injuries **caused by unauthorized replacement parts and accessories**.
6. During operation, some parts of the pump are subject to dangerous electric voltage. Work may only be performed on each pump or on the equipment connected to it after **disconnecting them from the mains power, and after disconnecting the starting device**.
7. The user should make sure that assembly and maintenance tasks are carried out by **qualified authorized persons** and that these persons have first carefully read the instructions for service and installation.
8. The operating safety of the pump is only guaranteed if the installation and service instructions are correctly followed.
9. The limit values stated in the Technical table **should not be exceeded under any condition**.
10. In the event of defective operation or fault, contact the technical support department of the manufacturer or its nearest authorized agents.
11. If the supply cord is damaged, it must be replaced by an authorized service agent.
12. This appliance is not intended for use by persons (including children) with reduced physical, sensory or mental capabilities, or lack of experience and knowledge, unless they have been given supervision or instruction concerning use of the appliance or instruction concerning use of the appliance.

WARNINGS FOR INSTALLATION AND ASSEMBLY TASKS

1. When connecting electric cables to the motor of the pump, be careful to correctly arrange them inside the connection box, verify that no bits of cable are left inside the box on closing it. **See that the earth wire is correctly connected.** When connecting the motor, follow the wiring diagram supplied with the pump.
2. Be especially careful **that no water enters the motor or electrical parts under voltage.**
3. In the event that the planned use is not as specified, adaptations and supplementary technical rules may be necessary.

• **WARNINGS FOR START UP**

Before starting the pump, verify the calibration of the electrical protection devices of the motor and that the protections against electrical and mechanical contacts are correctly positioned and attached.

WARNINGS FOR ASSEMBLY AND MAINTENANCE TASKS

1. **Be especially careful that no water enters the motor or the electrical parts under voltage.**
2. Avoid all contact, even accidental, with the moving parts of the pump.
3. Wait until the pump has stopped completely before handling it in any way.
4. **Before carrying out electrical or mechanical maintenance tasks, make sure that the machine has been disconnected from the mains and that starting devices have been locked.**
5. It is advisable to follow the steps listed below before handling the pump in any way.
 - a) Turn off the voltage to the pump.
 - b) Lock starting devices.
 - c) Verify that there is no voltage in the circuits, including ancillary devices and auxiliary circuits.
 - d) Wait until motor stops completely.

The above list should be considered indicative and not binding for the purpose of safety; specific safety rules may exist in particular regulations.

Regularly verify:

1. The correct attachments of the mechanical parts and of the support screws of the pump.
2. The correct position, attachment and condition of the supply cables and of the insulating parts.
3. The temperature of the motor. In the event of any irregularity stop the machine immediately and have it repaired.
4. The vibration of the pump. In the case of any irregularity, stop the machine immediately and have it repaired.

Owing to the complexity of the cases covered, the instructions for installation, use and maintenance contained in this manual do not attempt to examine all possible and imaginable cases of service and maintenance. If supplementary instructions are required or if special problems arise, do not hesitate to contact the distributor or to address directly the manufacturer of the pump.

TROUBLE SHOOTING

SYMPTOMS	PROBABLE CAUSE	ACTION
1. PUMP WILL NOT PRIME	Suction air leak	Make sure water level is correct through suction points. Ensure baskets and strainers are free of debris. Tighten all fittings / unions on the suction side of the pump, remove and replace mechanical seal.
	No water in the pump Closed valves or blocked lines	Make sure hair and lint pot is full. Open all valves in system, clean skimmer and pump basket, check pump impeller of blockage.
2. MOTOR WILL NOT RUN	No power to motor	Check that all electrical switches are on. Ensure the circuit breakers are properly set. Check if timer is set properly. Check motor wiring at terminals.
	Pump jammed	With power switched off turn pump shaft (should spin freely). If not contact electrician or nearest Waterco Limited branch for service.
3. LOW FLOW	Dirty filter	Backwash or clean cartridge.
	Dirty Skimmer and Pump strainer	Clean skimmer and pump strainer.
	Suction air leak Closed valve or blocked line	See 1. See 1.
4. MOTOR RUNS HOT	Low or incorrect voltage	Supply to be corrected by Electrician. Motors run hot to touch and is normal. Thermal overload protector will function to turn them off if there is an overload or high temperature problem.
	Installed in direct sunlight	Shield from the weather.
	Poor ventilation	Do not tightly cover or enclose motor.
5. NOISY PUMP OPERATION	Bad bearing	Have electrician replace.
	Air leak in suction	See 1.
	Suction blockage	Locate and clear blockage.
	Foreign matter in impeller	Dismantle pump and remove foreign matter and debris from around impeller.
	Cavitations	Improve suction, reduce suction lift, reduce number of fittings, increase pipe size, increase discharge pressure and reduce flow by throttling discharge valve.
6. MOTOR OVER LOAD CUTS OUT	Motor not connected properly	Have electrician check wiring.
	Low incoming voltage	Have electrician check voltage, ensure pump is not running on an extension cord. Report low supply to authorities.
	Over load due to binding in pump or wrong size impeller	Contact Waterco Limited for service.

Warning: If the Waterco Limited pump is within the stated warranty period and you experience faults always contact your supplier or the nearest Waterco Limited branch for advice. Failure to do this may void warranty. Refer to warranty documentation supplied with pump.

All electrical work is to be carried out by a Qualified Electrician; under no circumstances should you attempt repairs on the electrical components of Waterco Limited pumps unless you are qualified to do so.

OFFICES - AUSTRALIA

NSW - Sydney
(HEAD OFFICE)
Tel : +61 2 9898 8686
VIC/ TAS - Melbourne
Tel : +61 3 9764 1211
WA - Perth
Tel : +61 8 9273 1900
QLD - Brisbane
Tel : +61 7 3299 9900
SA/ NT - Adelaide
Tel : +61 8 8244 6000
ACT Distributor
Tel : +61 2 6280 6476

OFFICES - OVERSEAS

Waterco USA
Augusta, USA
Tel : +1 706 793 7291
Waterco Canada
St-Hyacinthe, QC, Canada
Tel : +1 450 796 1421
Waterco (Europe) Limited
Sittingbourne, Kent. UK
Tel : +44(0) 1795 521 733
Waterco (NZ) Limited
Auckland, New Zealand
Tel : +64 9 525 7570

Waterco (C) Limited
Guangzhou, China
Tel : +8620 3222 2180
Waterco (Far East) Sdn. Bhd.
Selangor, Malaysia
Tel : +60 3 6145 6000
PT Waterco Indonesia
Jakarta, Indonesia
Tel : +62 21 4585 1481

WATERCO

Waterco Limited ABN 62 002 070 733

Member
**WATER
QUALITY
ASSOCIATION** [®]

