

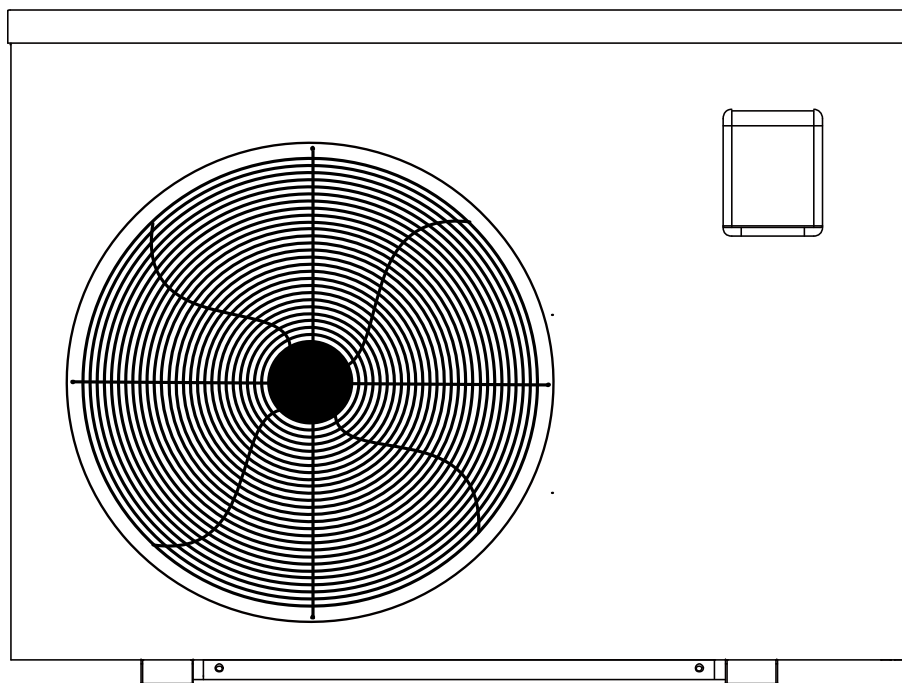

Summer Eco

INVERTER POOL HEAT PUMP



USER'S MANUAL

Table of contents

A. Foreword	4
B. Safety Precautions	5
1. Warning	5
2. Attention	6
3. Safety	6
C. About your heat pump	7
1. Transportation	7
2. Accessories:	7
3. Features	7
4. Operating condition and range:	8
5. Introduction of different modes:	8
6. Technical parameter	9
7. Dimensions	10
D. Installation guidance	11
1. Installation requirements	11
2. Placing the unit and water connections	12
3. Wiring	13
4. Electric wiring Diagram	13
5. Reference for protecting devices and cable specification	13
E. Operation guidance	14
1. Controller overview and key Function	14
2. Controller functions and settings	15
F. Testing	16
1. Heat pump checks before use	16
2. Refrigerant leak detection method	16
3. Trial run	16
4. Running status check	16
G. Maintenance	17
H. Trouble shooting for common faults	19
I. Appendix	21
J. WiFi operation	1

A. Foreword

Thank you for choosing the Madimack high efficiency inverter pool heat pump.

All our heat pumps are built and designed to the highest standard and are protected by our extended warranty service for peace of mind.

We hope you enjoy using our heat pumps.

Thank you!

B. Safety Precautions

We have provided important safety messages in this manual for the installation, maintenance and repair of your heater.

Please read thoroughly and obey all safety messages.

Environmentally friendly R32 Refrigerant is used in this heat pump

1. Warning



a. This WARNING sign denotes a hazard. It calls attention to a procedure, practice, or the like, which, if not correctly performed or adhered to, could result in personal injury or injury to a third party. These signs are rare, but are extremely important.

	a. Keep the heat pump away from fire sources.
	b. It must be placed in a well-ventilated area; indoor or enclosed areas are not allowed.
	c. Repair and disposal must be carried out by trained service personnel
	a. Vacuum the system completely before welding. Welding should only be carried out only by professionally trained personnel.

Safety Precautions

2. Attention

- a. Please read the following instructions before installation, use and maintenance.
- b. Installation, must be completed only by competent persons only, and in accordance with this manual.
- c. Check all water connections are sealed and testes before operating the machine
- d. Except for the methods recommended by the manufacturer, do not use any methods to accelerate the defrosting process or clean the frosted parts.
- e. If a repair is required, please contact the nearest after-sales service center. The repair process must be strictly in accordance with manual. Repairs made by unauthorized persons may void the warranty.
- f. Correctly set temperature required for personal preference making sure to avoid overheating or overcooling.
- g. Please do not stack substances or other materials which may block the air flows to the inlet or outlet areas. This causes the efficiency of the heater to be reduced, and may damage the machine.
- h. Do not use or stock combustible gas or liquids such as thinners, paint and fuel, to avoid fire!
- i. In order to optimize the heating effect, please install heat preservation insulation on pipes between swimming pool and the heater, and please use a recommended cover on the swimming pool.
- j. Connecting pipes of the swimming pool and the heater should be less than 10m.

3. Safety

- a. Please keep the main power supply switch out of reach from the children.
- b. If power is suddenly disconnected during operation, and later the power is restored, the heater will start up automatically.
- c. Please switch off the main power supply in high storm weather to prevent the machine from damage that could be caused by lightning strikes.
- d. Any repairs should be carried out in a well-ventilated area. Any source of ignition is prohibited during the inspection.
- e. Safety inspection must be carried before the maintenance or repair for heat pumps with R32 gas in order to minimize the risk.
- f. If R32 gas leaks during the installation process, all operations must be stopped immediately and call the service center.

C. About your heat pump

1. Transportation

a. Always keep upright

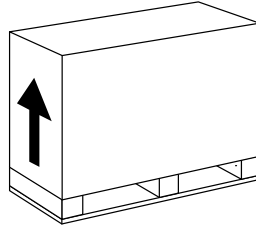

b. Do not lift with the water unions
(The titanium heat exchanger
inside the heat pump may be damaged)

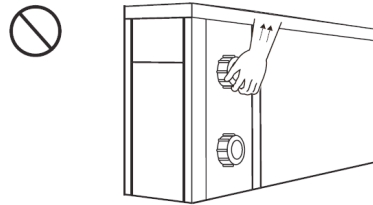

2. Accessories:

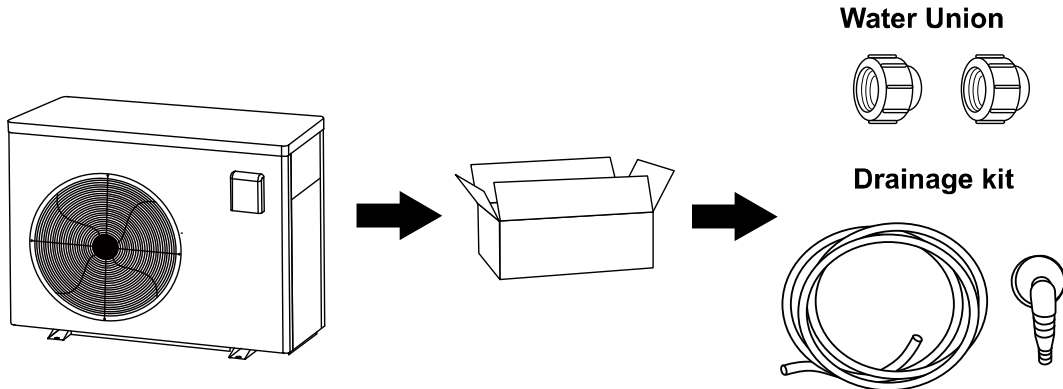

3. Features



- Stable DC inverter compressor
- EEV Technology
- Quick hot gas defrosting with Saginomiya 4-way valve
- High-efficiency twisted titanium heat exchanger
- High pressure and low pressure protection
- Soft start & wide voltage application
- Stable inverter control system

4. Operating condition and range:

- a. Air temperature operating range: 0°C~43°C
- b. Heating temperature setting range: 18°C~35°C
- c. The heat pump will have best performance in operating temperature range of ambient Air 15°C~25°C

5. Introduction of different modes:

- a. The heat pump has two modes: Boost and Silence.
- b. They have different strengths under different conditions.

Mode	Modes	Strength
	Boost mode	Heating capacity: 20% to 100% capacity Intelligent optimization Fast heating
	Silent mode	Heating capacity: 20% to 80% capacity Sound level: 3dB (A) lower than Boost mode

6. Technical parameter

Model	SUME60 /240MM	SUME80 /240MM	SUME110/ 240MM	SUME130/ 240MM	SUME160/ 240MM	SUME200/ 240MM	SUME250/ 240MM
PERFORMANCE CONDITION: Air 27°C/ Water 27°C/ Humid. 80%							
Heating capacity (kW)	6.3	8.0	9.5	13.0	16.0	20.0	25.0
COP Range	5.5~10.1	5.2~10.1	5.4~10.5	5.6~10.8	5.8~10.9	5.7~10.5	5.8~11
PERFORMANCE CONDITION: Air 15°C/ Water 26°C/ Humid. 70%							
Heating capacity (kW)	4.4	6.0	7.0	9.5	11.2	13.5	17.0
COP Range	4.1~6.3	4.0~6.2	4.2~6.5	4.0~6.2	4.3~6.6	4.2~6.5	4.0~6.6
TECHNICAL SPECIFICATIONS							
Advised pool volume (m ³) *	15~25	20~40	25~50	35~65	40~75	50~90	60~110
Operating air temperature (°C)	0°C~43°C						
Rated input power (kW)	0.21~1.07	0.29~1.50	0.32~1.67	0.45~2.38	0.50~2.60	0.62~3.21	0.76~4.25
Rated input current (A)	0.94~4.88	1.32~6.82	1.47~7.58	2.05~10.80	2.27~11.84	2.80~14.61	3.44~19.32
Maximum input current (A)	6.5	8	9.5	12.5	17	19.5	20
Sound level at 10m dB(A)	19.8~31.2	21.8~32.1	21.6~33.5	23.9~34	26.2~37.3	26.3~38.1	26.9~38.7
Advised water flux (m ³ /h)	2~4	2~4	3~5	4~6	6~8	7~10	10~12
Water connection (mm)	40						

Remarks:

This heat pump is able to perform normal within air temp 0°C~+43°C, efficiency will not be guaranteed out of this range. Please take into consideration that the pool heater performance and parameters are different under various conditions.

Related parameters are subject to adjustment periodically for technical improvement without further notice. For up to date details please refer to nameplate on the heat pump.

7. Dimensions

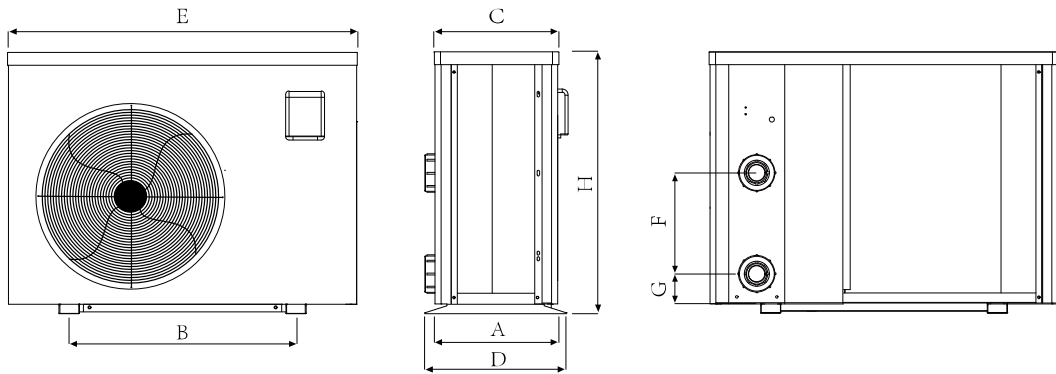

Size(mm) / Name / Model	A	B	C	D	E	F	G	H
SUME60/240MM	324	560	348	349	872	250	74	654
SUME80/240MM	324	560	348	349	872	250	74	654
SUME100/240MM	324	560	348	349	872	250	74	654
SUME130/240MM	324	560	348	349	872	290	74	654
SUME160/240MM	324	590	348	349	962	350	74	654
SUME200/240MM	324	590	348	349	962	390	74	754
SUME250/240MM	404	720	388	429	1084	620	74	948

※ Above data is subject to modification without notice.

Please note the picture above and specification diagram of the pool heater is for the technician's installation and layout reference only. The product is subject to adjustment periodically for improvement without further notice.

D. Installation guidance

1. Installation requirements

Only competent persons are authorised to install the heat pump and should be educated with the relevant building codes and standards of their current state or local governing body for all electrical, mechanical and water services to prevent danger or damage to the unit.

a. Location and clearances



The inverter pool heat pump should be installed in a well-ventilated place.

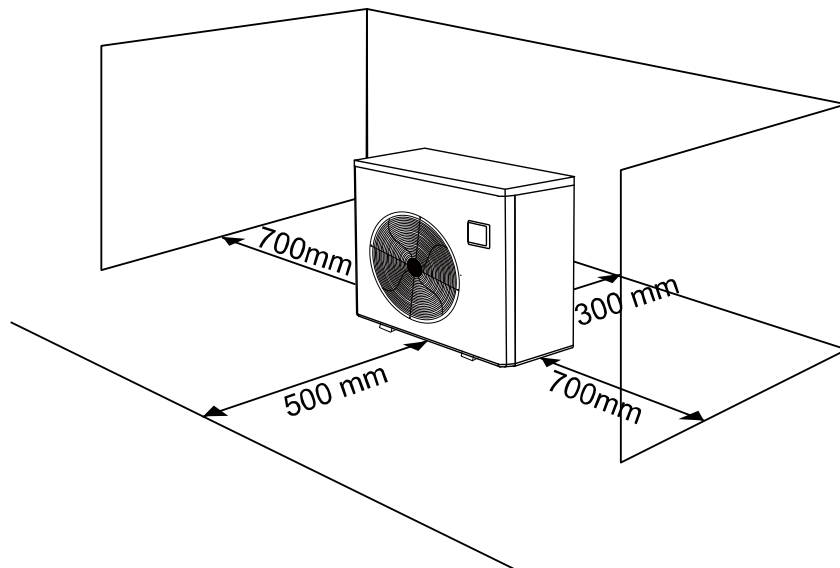

b. Typical plumbing installation diagram

Please note water connection locations may differ from the diagram and are for illustration only

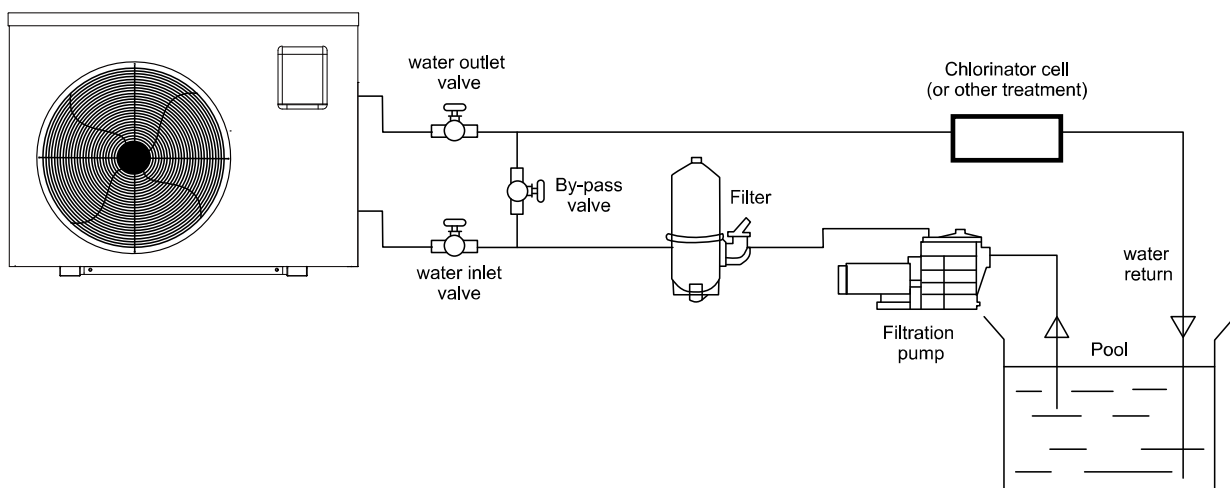

2. Placing the unit and water connections

a. Placing the unit and fixing

- The frame must be fixed by bolts (M10) to a concrete foundation or brackets. The concrete foundation must be solid and fastened; the bracket must be strong enough and anti-rust treated.
- Do not stack substances that will block air flow near the inlet or outlet area, and there should be no obstruction within 50cm behind the machine. Suffocation of air reduces the efficiency of the heater and could damage the unit.
- If the machine needs an appended pump (not supplied). The recommended pump must adhere to the specification-flux, please refer to the Technical Parameters.

b. Water connections and condensation

- The inlet and outlet water unions should not be installed with soft flexible pipes. The heat pump **must** be connected with rigid pipes!
- When the machine is running, condensation is created and discharged from the bottom. Please place the drainage nozzle (accessory included) into the hole and clip it well, then connect a pipe to drain the condensation water away.

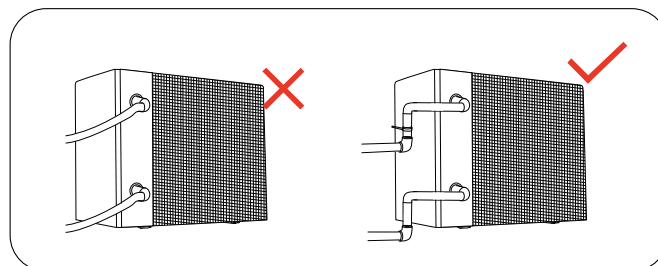

3. Wiring

- Connect to appropriate power supply, the voltage should comply with the rated voltage of the products.
- The machine **must** be earthed
- Wiring must be handled by a professional technician according to the circuit diagram.
- Set earth leakage protector according to local code for wiring (leakage operating current $\leq 30\text{mA}$).
- The layout of power cable and signal cable should be orderly and not affecting each other.

4. Electric wiring Diagram

For power supply: 230V/50Hz

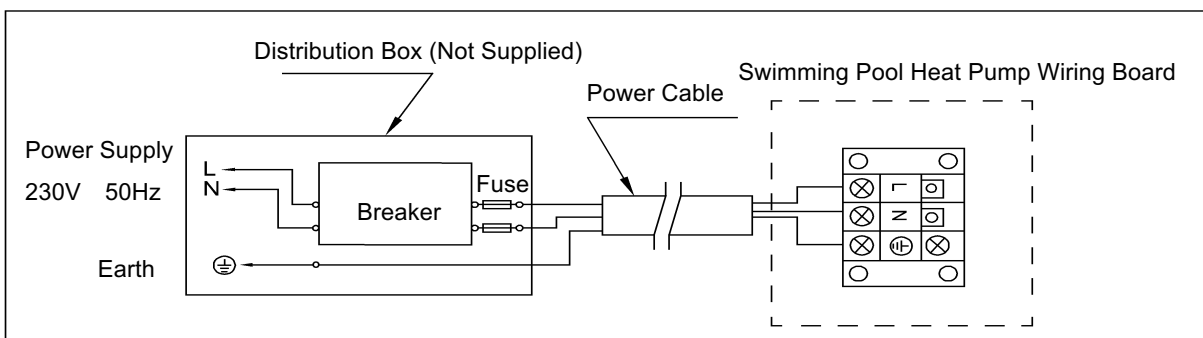

5. Reference for protecting devices and cable specification

MODEL		SUME60/ 240MM	SUME80/ 240MM	SUME110 /240MM	SUME13 0/240MM	SUME16 0/240MM	SUME20 0/240MM	SUME25 0/240MM
Breaker	Rated Current A	8	9.5	11.5	15	20.5	23.5	24
	Rated Residual Action Current mA	30	30	30	30	30	30	30





※ Above data is subject to modification without notice.

Note: The above data is associated to power cables less than 10m. If power cable is longer than 10m, the wire diameter must be increased in accordance with current regulations. The signal cable can be extended to a maximum of 50m.

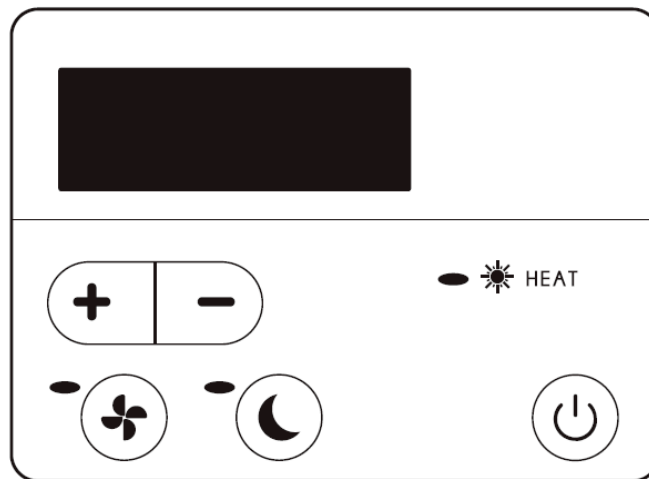
E. Operation guidance

1. Controller overview and key functions



Symbol	Designation	Function
	ON/OFF	Power On/Off
	Boost Mode	Press to start Boost mode
	Silence Mode	Press to start Silence mode
	UP/DOWN	Temperature Setting & Displaying

Attention:

The controller has a built-in memory so all parameters are saved in the event of power loss

2.Controller functions and settings

a. Switching the unit on and mode selection

- **Power On & Power Off**

Press  to power on or power off machine.

- **Temperature Setting**

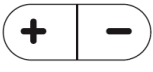
Press  to display and adjust set temperature.

- **Mode Selection**



Press  to start boost mode, and light will turn on.

Press  to start silence mode, and light will turn on.





* Default mode is set to full power boost mode.

b. Defrosting

- Automatic active defrosting:

When machine is defrosting,  starts flashing; after defrosting  is on continuously

- Forced defrosting: When the machine is heating and the compressor is working continuously for

10 minutes, In heating mode, press  and  on controller simultaneously for 5 seconds to start forced defrosting, when  symbol is flashing, defrost starts, when  symbol stops flashing forced defrost has stopped.

*Note: the interval between forced defrosting should be more than 30 minutes.

F. Testing

1. Heat pump checks before use

- The air inlets and outlets are free of any debris and are not obstructed.
- Refrigeration pipes or components are not installed in a corrosive environment.
- Check electric wiring and connections are tight adhere to electrical schematic and the unit is fully earthed
- Check for water leaks around the machine and all new water connections





2. Refrigerant leak detection method

- Leak testing is prohibited in enclosed areas
- Any source of ignition is prohibited during leak checks. A halide torch (or any other detector using a naked flame) should not be used.
- Leak detection fluids can be applied with most refrigerants but the use of products containing chlorine should be avoided as the chlorine may react with the refrigerant and corrode the copper pipe.
- Vacuum machine completely before welding. Welding can only be carried out by a professional person in a service center.
- Please stop immediately if a gas leak occurs, and contact your local service center.

3. Trialrun

- The circulation pump must start before the heat pump and stop after the heat pump to avoid any damage occurring to the machine.
- Before starting the heat pump, please check for any leaks of water or other dangers.
- In order to protect the heat pump pool heater, the machine is equipped with a time lag start function, the fan will run 1 minute earlier than the compressor when starting the machine, and it will stop running 1 minute later than the compressor when power off the machine.
- After the heat pump starts, check for any abnormal noises from the machine.

4. Running status check

- Press and hold  symbol for five seconds, to enter running status mode.
- After five seconds the display will show status code C0 and a corresponding value
- Change status code by pressing  or 
- Press  to quit running status mode

Running status codes and corresponding value

Code	Content	Unit
C0	Inlet water temperature	°C
C1	Outlet water temperature	°C
C2	Ambient air temperature	°C
C3	Exhaust air temperature	°C
C4	Outer coil pipe temperature	°C
C5	Refrigerant gas suction temperature	°C
C6	Inner coil pipe temperature	°C
C9	Radiator temperature	°C
C10	Electronic expansion valve opening	P

F. Commissioning

1. Flow Rates

Each Pool Heat Pump has a minimum flow rate requirement please check the specification table water flux section to ensure the circulation pump in use is adequately sized.

Calibrating the flow rate.

By using the running status function on the touch controller, it is easy to calibrate the check valves installed for optimum flow rates through the heat pump.

OPTIMUM FLOW RATE DIFFERENTIAL FROM INLET TO OUTLET IS BETWEEN 2-4 DEGREES

Madimack Heat Pumps have a built-in flow switch which will deactivate the heating function if not enough water flow is detected. The Heat Pump has a large range operation up to a seven-degree differential. If the temperature differential is above 8 degrees, the flow switch or E6 Error will be displayed indicating not enough flow detected.

Recommended procedure

- a. Fully open all valves including the by-pass and switch the unit on to max temp.
- b. If Error E3 is displayed slowly close by pass valve until unit initiates.
- c. Wait 3-4 minutes until heat pump is at 100% Capacity
- d. Check inlet and outlet temperature through the on screen controller running status check
- e. Open the by-pass valve to increase temperature differential
- f. Close the by-pass valve to decrease temperature differential
- g. Once optimum temperature achieved lock position of by-pass if possible.

G. Maintenance



“SWITCH OFF” power supply to the heater
before cleaning, examination or repairing

1. Precautions in winter season when the unit is due to not be operating for a long period of time.
 - a. Switch off all power supply to prevent any machine damage.
 - b. Drain water completely from the machine.
 - c. Cover the machine when not in use.

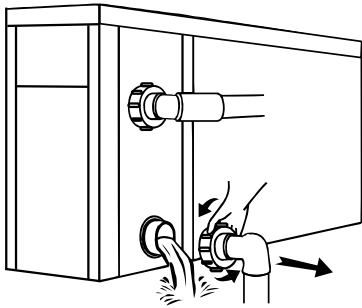

!!!Important:

Unscrew the water nozzle of inlet pipe to let the water flow out.

When the water in machine freezes in winter season, the titanium heat exchanger may be damaged.

2. Please clean this machine with household detergents or clean water, NEVER use gasoline, thinners or any similar fuel.
3. Check bolts, cables and connections regularly.
4. If repairs or removal is required, please contact an authorized service center.
5. Do not attempt to work on the equipment by yourself. Improper operation may cause danger.
6. To reduce risks, safety inspections must be carried before the maintenance or repairing for heat pumps with R32 gas.

H. Trouble shooting for common faults

1. Repairing Guidance



WARNING:

If repairs or removal is required, contact authorized service center.

Requirements for Service Personnel

- a. Any person who is involved with working on or breaking into a refrigerant circuit should hold a current valid certificate from an industry-accredited assessment authority, which authorizes their competence to handle refrigerants safely in accordance with an industry recognized assessment specification.
- b. Do not attempt to work on the equipment by yourself. Improper operation may cause danger.
- c. Strictly comply with the manufacturer's requirements when charging R32 gas and equipment maintenance. This chapter focuses on special maintenance requirements for swimming pool heat pump with R32 gas. Please refer to the technical service manual for detailed maintenance operation.
- d. Vacuum system completely before welding. Welding should only be carried out by professional person in a service center.

2. Failure solution and code

Failure	Reason	Solution
Heat pump doesn't run	No power	Wait until the power recovers
	Power switch is off	Switch on the power
	Fuse may be broken	Check and change the fuse
	The circuit breaker is off	Check and turn on the breaker
Fan running but with insufficient heating	Evaporator is blocked	Remove the obstacles
	Air outlet blocked	Remove the obstacles
	3 minutes start delay	Wait patiently
Display normal, but no heating	Set temp. too low	Set proper heating temperature
	3 minutes start delay	Wait patiently
If above solutions don't work, please contact your installer with detailed information and your model number. Don't try to repair it yourself.		

Note: If the following conditions happen, please stop the machine immediately, and cut off the power supply immediately, then contact your dealer:

1. Inaccurate switch action.
2. The fuse is frequently broken or earth leakage detector activated often

Protection & Failure code

NO.	Display	Not failure description
1	E3	No water flow protection
2	E5	Power supply excesses operation range
3	E6	Excessive temp difference between inlet and outlet water. (Insufficient water flow protection)
4	Eb	Ambient temperature too high or too low protection
5	Ed	Anti-freezing reminder
NO.	Display	Failure description
1	E1	High pressure protection
2	E2	Low pressure protection
3	E4	3 phase sequence protection (three phase only)
4	E7	Water outlet temp too high or too low protection
5	E8	High exhaust temp protection
6	EA	Evaporator overheat protection (only at cooling mode)
7	P0	Controller communication failure
8	P1	Water inlet temp sensor failure
9	P2	Water outlet temp sensor failure
10	P3	Gas exhaust temp sensor failure
11	P4	Evaporator coil pipe temp sensor failure
12	P5	Gas return temp sensor failure
13	P6	Cooling coil pipe temp sensor failure
14	P7	Ambient temp sensor failure
15	P8	Cooling plate sensor failure
16	P9	Current sensor failure
17	PA	Restart memory failure
18	F1	Compressor drive module failure
19	F2	PFC module failure
20	F3	Compressor start failure
21	F4	Compressor running failure
22	F5	Inverter board over current protection
23	F6	Inverter board overheat protection
24	F7	Current protection
25	F8	Cooling plate overheat protection
26	F9	Fan motor failure
27	Fb	Power filter plate No-power protection
28	FA	PFC module over current protection

I. Appendix

Water pump: 230V, less than 500W

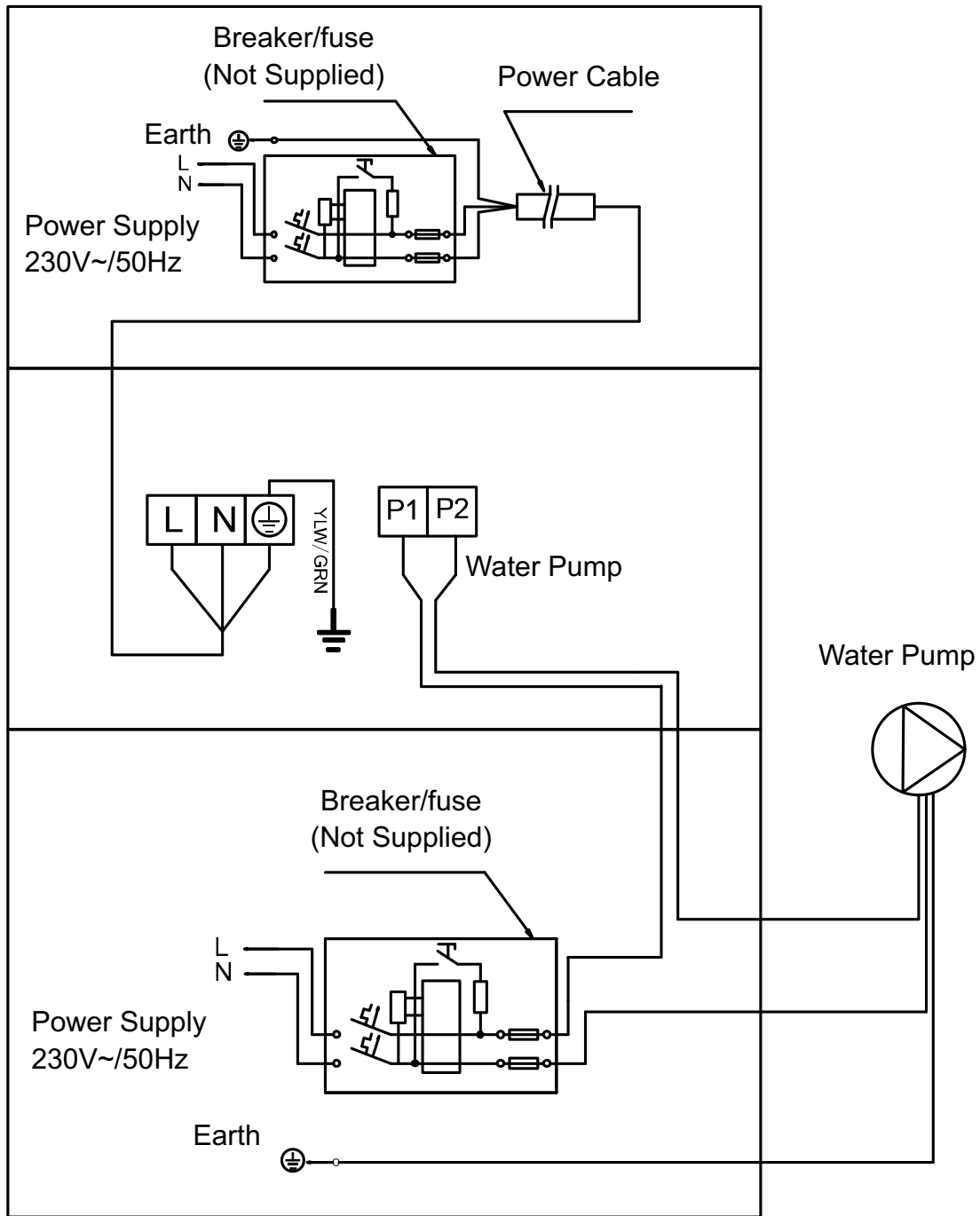

Water pump: 230V, over 500W

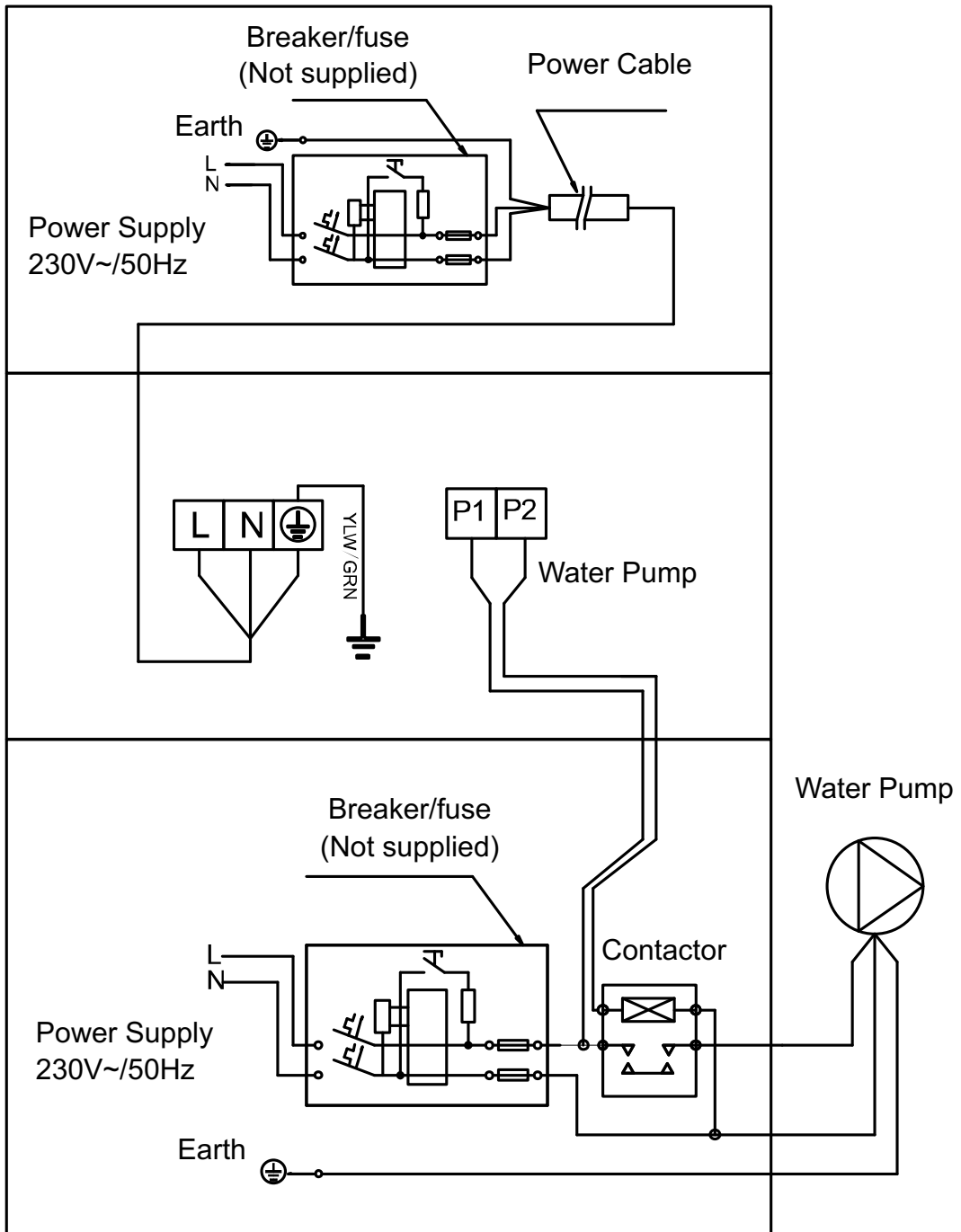

Water pump control and timer connection

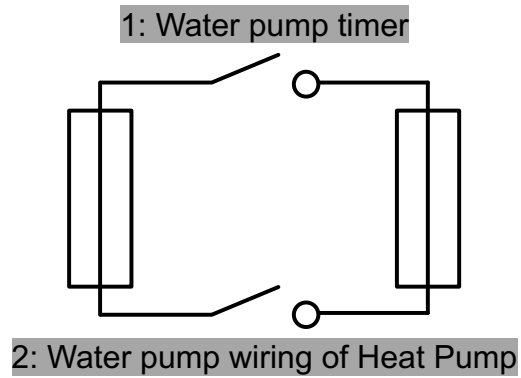

Note: The installer should connect 1 parallel with 2 (as above picture). To start the water pump, condition 1 or 2 is connected. To stop the water pump, both 1 and 2 should be disconnected.

J. WiFi operation

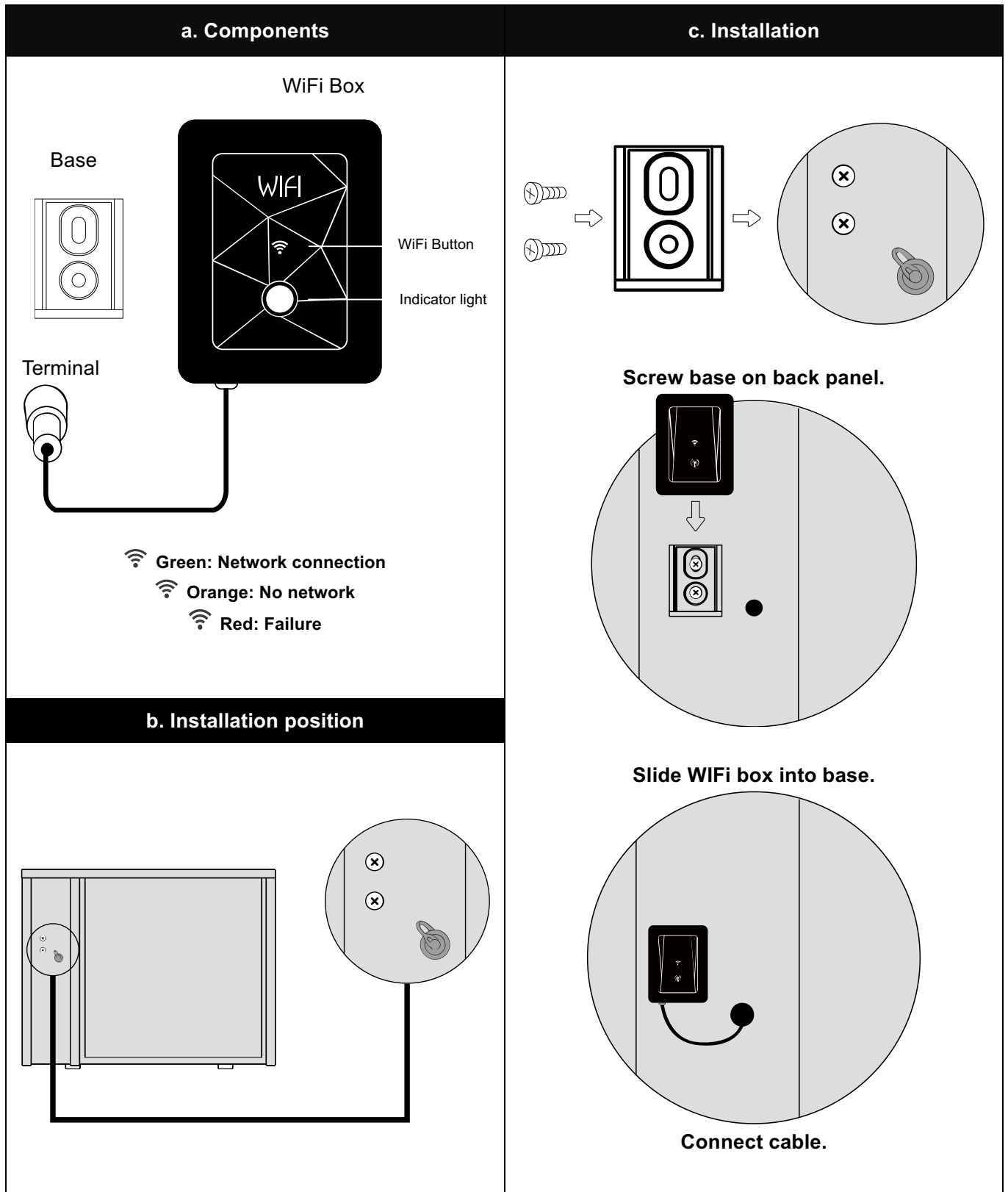

1. APP Download



Android mobile please download from



iPhone please download from



2. APP Binding



a. Press WiFi button  for 3 seconds to enter binding program,  light will flash.

b. Enter "Configure new device" in APP, follow indication to finish binding.

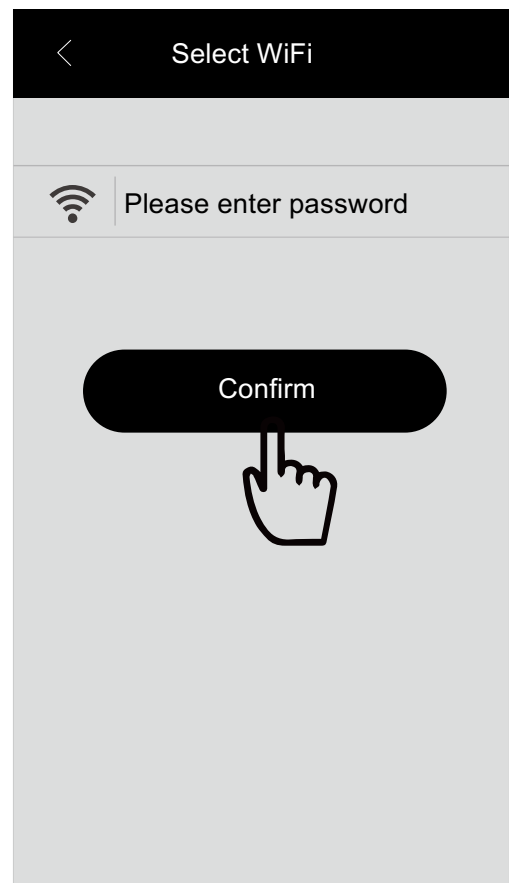

3. Operation(Heating Only)

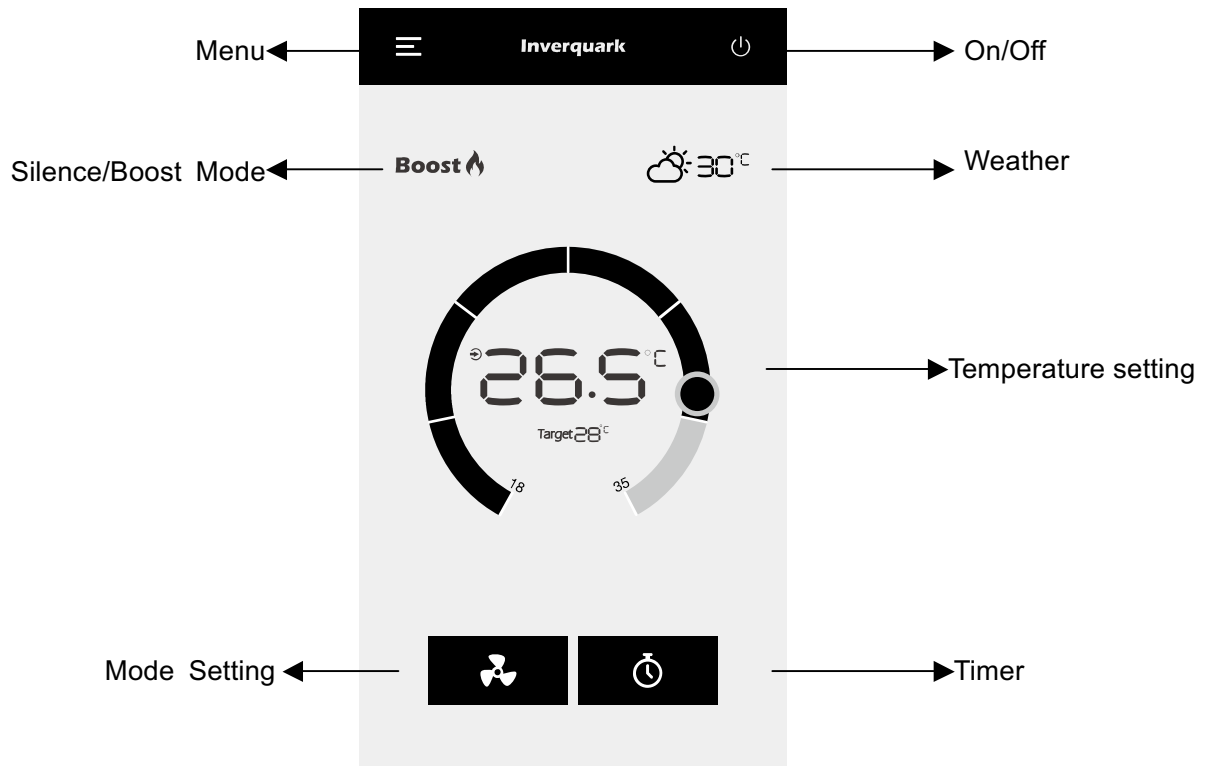

4. Operation(Heating& Cooling)

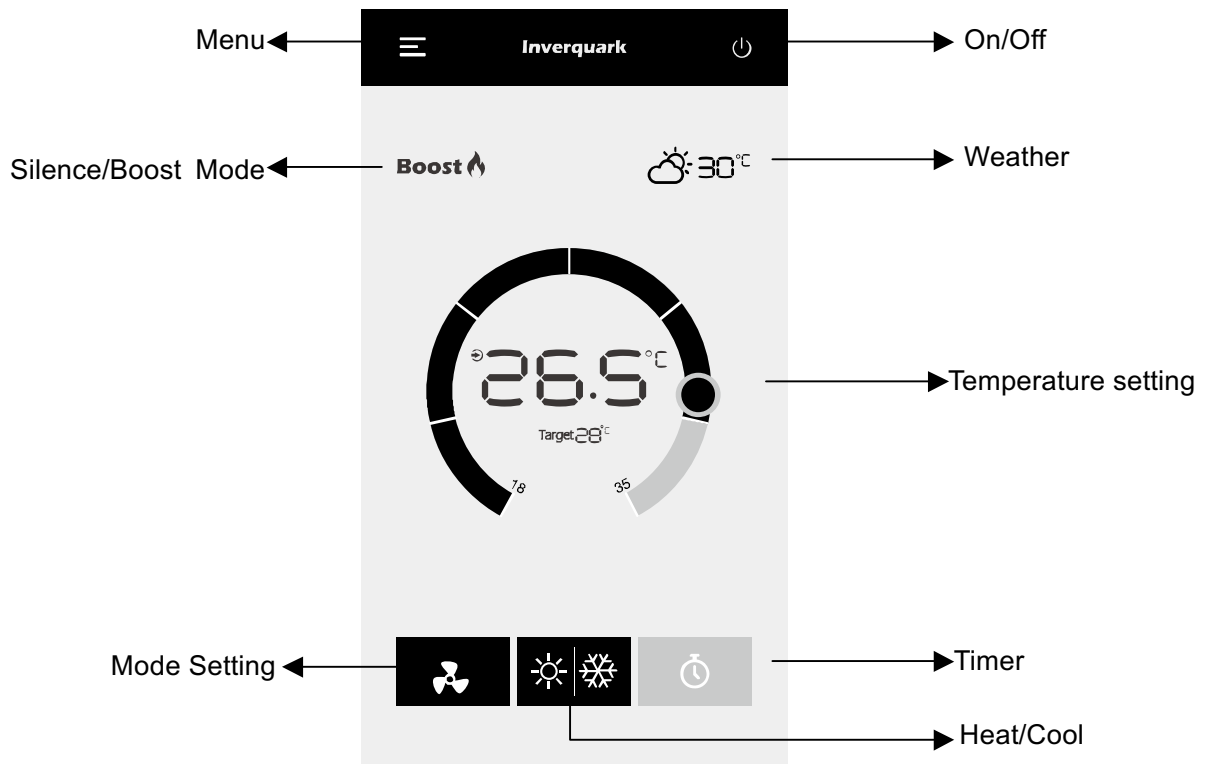

Notice:

1. If WiFi signal does not cover machine, please speak to your electrician to expand WiFi network
2. The weather forecast is for reference only.

This App is subject to updating without notice.

