

## INSTALLATION INSTRUCTIONS

**INSTALLER** – READ ENTIRE INSTRUCTION SHEET BEFORE PROCEEDING TO INSTALL.

**POOL OWNER** – PLEASE KEEP THESE INSTRUCTIONS FOR FUTURE REFERENCE.

**PLEASE NOTE**  
**THESE INSTALLATION INSTRUCTIONS APPLY TO**  
**AQUA-QUIP EVO2 LED LIGHTS FOR CONCRETE POOLS ONLY.**

Included in the package are the following items:



Evo2 Flush Mounted Pool Light – Concrete

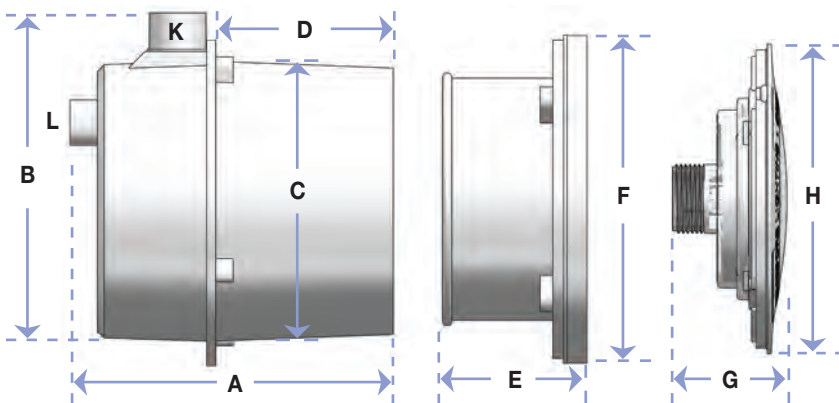

Dimensions for the major components of Aqua-Quip Evo2 LED Pool Lights are obtained by cross-referencing the relevant code against the table

CODE	DIMENSIONS (mm)
	<b>EVO2</b>
A	144
B	154
C	120 max
D	79
E	63
F	143
G	49
H	135

**K** Accepts 20mm conduit or 25mm socket

**L** Accepts 20mm socket

## HOUSING INSTALLATION

**Housing Installation** – see Diagram 1

**1 Evo2 Housing** should be tied to the steel reinforcing, before concreting the pool. A **red Concrete Cap** is supplied to fit inside the front of the Housing prior to concreting.

**2 The Housing** has two conduit connection points to accept rigid PVC conduit, do not use flexible conduit. Choose the appropriate provision for the situation and run conduit above water level to form an anti-siphon loop. Top provision accepts 20mm conduit or 25mm conduit fitting. This is the most popular choice as it features a cable gland fitting on the interior of the **Housing**. Rear provision accepts 20mm coupling. If using the **Rear Provision**, be sure to plug the **Top Provision** using a 25mm conduit cap.

**3** Use tie wire or cable ties through the holes on the outer perimeter of the **Housing** to securely fasten it to the steel reinforcing bars. Position the **Housing** so that the front will finish level with the concrete.

**4** It is very important to locate **Housing** at a suitable location and depth to allow for future servicing of the pool light. Excavate sufficiently around the rear of the **Housing** to allow approximately 100mm of concrete to encase it. If pool is out of ground and fully formed, ensure the formwork allows for concrete to encase the **Housing**.

**5** During pouring/spraying, concrete should be undercut around the front perimeter of the **Housing** to allow for a construction adhesive to be applied prior to the application of the internal pool surface.

**6** Concrete should be applied to reduce the likelihood of a void occurring on the underside of the **Housing**. Once concrete has cured, construction adhesive must be applied around the **Housing** to seal it to the concrete.

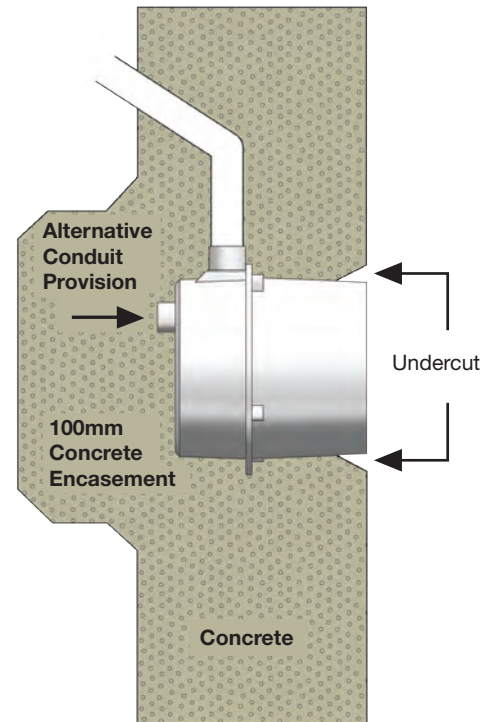

Diagram 1 – After Concreting

### TECHNICAL SPECIFICATIONS EVO2 LED FLUSH MOUNTED POOL LIGHTS

Nominal Supply Voltage:	12V AC 50/60 Hz
Voltage Tolerance:	+20%, -20%
Protection Rating:	IPX8 (to 2.0m depth)
Temperature Range:	-10°C ~ +40°C water temperature
Power Consumption:	White, blue and green = 8 VA
Power Consumption:	Spectrum III Multi Colour = 16 VA maximum
Lamp Life:	>50,000 hours
Light Output (typical):	White-550 lumens, blue-180 lumens, green-500 Lumens
Fault Protection:	Power-cycle “run dry” thermal cut-out. Voltage transient clamping.



Evo2 LED Lights must only be operated underwater as they are water-cooled.

Install in an accessible location, ensure that sufficient cable is wound up inside the housing to allow the light to be floated to the deck level. If being installed facing up, ensure that there is minimum 100mm of water cover.

Evo2 LED Pool Lights can be installed on a vertical or horizontal pool surface. Up to 1.6m of cable can be wound up inside the Evo2 Concrete Housing.

## DRESS RING INSTALLATION

### Adjustable Dress Ring Installation –

After Concreting and Sealing (Diagram 2)

**7** Remove **red-coloured Concrete Cap**. Use pvc glue or construction adhesive to secure the **Adjustable Dress Ring** inside the **Housing** to your required depth and alignment. If **Housing** protrudes out from the concrete, a maximum of 20mm can be cut off from the front. If the housing has been set back too far in the wall, then a special extension ring (P/N ASL 076) is available. The eyeball feature on the **Adjustable Dress Ring** allows adjustment so that the **Adjustable Dress Ring** face can be aligned flush with the anticipated pool interior finish even if the **Housing** is out of alignment. When gluing or securing the **Adjustable Dress Ring**, ensure that 2 of the screw holes are located horizontally.

**8** Evo2 **Cable** can be drawn through, excess cable must be coiled up and stored inside **Housing**. The **Connector Cap** must remain on end of **Quick Connect Plug Kit**. **Important: Allow enough cable to enable pool light to be floated to pool deck.**

**Cable Seal Assembly** is factory-fitted onto the black cable. Slide the **Cable Clamp, Seal, Washer** and **Cable Nut** up the cable and tighten onto the male thread that is fixed to the inside of the **Housing**. This will prevent water entering the conduit.

**9** The **Adjustable Dress Ring** is now in position ready for the pool interior to be applied. Push on the **green-coloured Plaster Cap** into the **Adjustable Dress Ring** by lining up the arrows on the **Plaster Cap** with the screw provisions on the **Adjustable Dress Ring**, push in firmly. Pool interior should finish flush with the front face of the **Adjustable Dress Ring**.

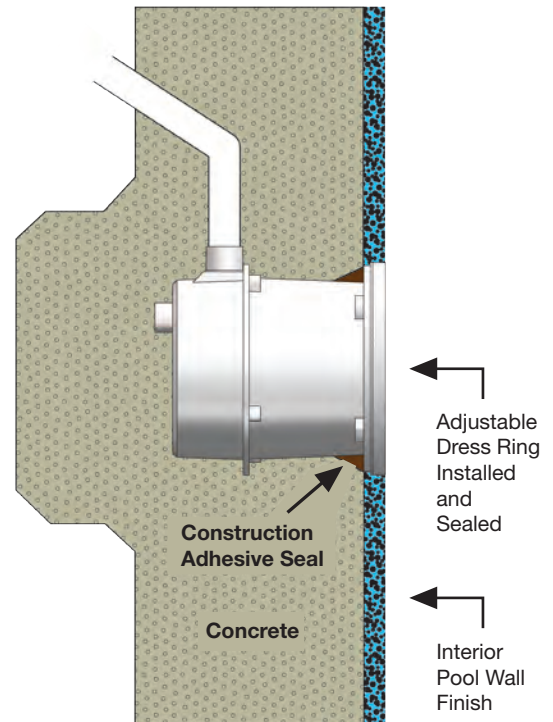

Diagram 2 – Sealing

### AQUA-QUIP EVO2 LED QUICK CONNECT PLUG KIT



The Evo2 LED pool light cable is 2-core, 1mm<sup>2</sup> cable with an outer diameter of  $\pm 7$ mm.

It is supplied factory fitted with the Quick Connect Plug Kit and Protective Connector Cap. This allows the installer/builder to install the cable and build the pool without the need to connect the pool light until just prior to filling.

The cable is also supplied factory fitted with the Cable Seal Assembly. The components of the Cable Seal Assembly will slide up the cable, tighten and seal onto the male thread that is fixed to the inside of the housing, preventing pool water from entering the conduit.

## POOL LIGHT INSTALLATION

### Pool Light Installation

**10** Remove **green-coloured Plaster Cap**. Clean any debris that may have entered the **Housing** and **Adjustable Dress Ring** during pool construction. Unwind Evo2 **Cable** and unscrew the white **protective Connector Cap** and remove it (retain for possible future use). Ensure the two O-rings are lubricated and in good order, clean any grit or dust that may be around the O-rings. Push the **Quick-Connect Plug Kit** into the rear of the Evo2 Pool Light and tighten **Connector Nut** firmly by hand. Insert and coil up excess cable into the **Housing**.

Evo2 self-locates onto the **Adjustable Dress Ring**, use two 5/8" CSK stainless steel screws provided to attach pool light to **Adjustable Dress Ring**, do not overtighten.

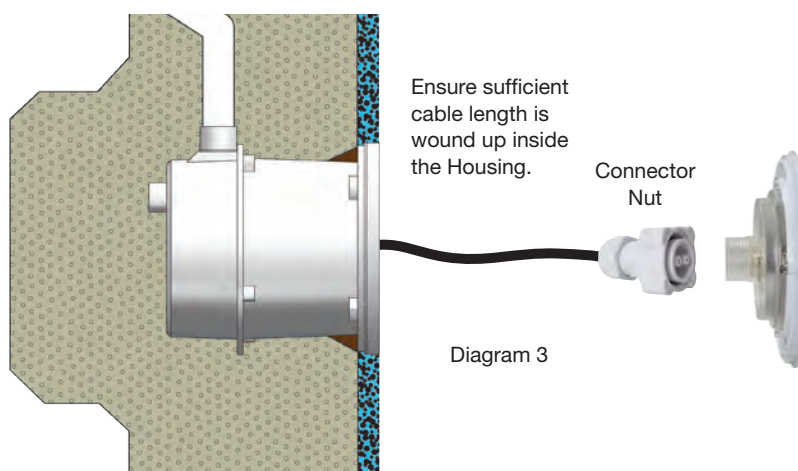

**11** Fit optional Polished **Stainless Steel Trim Ring** if required, using the 7/8" CSK stainless steel screws provided in the Stainless Steel Trim Ring Kit.

**12** Only turn pool light on when completely submerged under water.

The Evo2 LED Pool Light is factory-sealed and is not user-serviceable.

### ELECTRICAL CONNECTION AND OPERATION

- Install Light(s) and Transformer(s) in accordance with AS/NZS 3000:2007 as amended.
- Aqua-Quip's extra low voltage Transformers have either 2 or 4 secondary outputs, each being 12v 50VA, refer to Diagram 1.
- Dimming of Evo2 LED Fixed Colour Lights (i.e. white, blue and green) is possible. Aqua-Quip recommends the HPM Leading Edge Dimmer Cat. 200L. Evo2 Multi-Colour LED Lights cannot be dimmed.
- If your lights are Evo2 Multi-Colour, then see included "LED Programming Instructions".

### TRANSFORMERS

Diagram 4 – Transformers



APL502 and APL 512 run up to 2 x 50VA lights.

APL504 and APL514 run up to 4 x 50VA lights.

### WARNING

Never stare directly at LED Pool Lights. Prolonged direct exposure can cause eye damage.