



AIRLESS PAINT LINE STRIPER SERVICE/OPERATION MANUAL



Spray and Stripe 3000

TABLE OF CONTENTS

SECTION	FIGURE
Introduction.....	1
Safety Warnings	2
Setting Up.....	5
Flushing	5
How to Flush	6
Starting Up	7
Pressure Relief Procedure	8
Daily Maintenance	8
Line Striping Operation.....	9
Airless Spray Gun Operation.....	10
Airless Spray gun Assembly	11
Airless Spray Gun Troubleshooting.....	12
Rev Tips	13
Field Troubleshooting	13
Servicing Fluid Pump	14
Servicing Outlet Valve	15
Servicing Inlet Valve	15
Packing Replacement Procedures	16
Inspection/Replacement of Control Valve.....	18
Pressure Control Calibration	18
Bypass Valve Assembly.....	19
Gearbox Assembly	20
Frame Assembly.....	21
Spray Gun Assembly	22
Gun Mount Assembly	22
Suction Assembly	23
Striping Accessories	24
Notes	25
Airlessco Accessories.....	26
1 Filling the Packing Nut/Wet Cup.....	5
2. Spray Tip	6
3. Control Valve	6
4. Choke, Fuel Throttle	6
5. Static Discharge	6
6. Gun Safety Latch.....	10
7. Major Gun Components	10
8. Spray Tip	10
9. Spray Tip Assembly	10
10. Airless Spray Gun Assembly	11
11. Fluid Pump.....	14
12. Outlet Valve	15
13. Inlet Valve	15
14. Packing.....	16
15. Packing Cutaway	17
16. Bypass Valve Assembly.....	19
17. Gearbox Assembly	20
18. Frame Assembly.....	21
19. Spray Gun Assembly	23
20. Gun Mount Assembly	23
21. Suction Assembly	23



INTRODUCTION



The Spray & Stripe 3000 is a mobile airless sprayer designed to be used and strong enough to stripe parking lots yet light on it's wide tires to stripe sports fields. Plus it's based on a contractor quality paint spray pump so the gun can be snapped out of its holder and can be used as a mobile airless painting system for general exterior painting. Built on a compact, well balanced frame, with "No Tools" removable handlebars, the 3000 combines a dependable commercial 4-cycle engine, and the proven durability of our LP "Slow-Stroking" stainless steel piston paint pump.

Forget about stripers that lack the power to spray pure paint. The 3000 is H2NO READY!, so you don't have to figure out how much water to add to the paint to properly atomize at the pressure designed into the sprayer. You simply just adjust the 3000's pressure control knob for optimal atomization of pure paint, or the water/paint mix that you want to spray or stripe with.

	SS3000
Part No.	305-401
Max Pressure	1500 PSI
Output (At Pressure)	0.62 GPM
Tip Size 1 Gun	0.025 in.
Motor	Durotech 4HP
Weight	162 lbs

WARNING

**HANDLE THIS UNIT AS YOU WOULD A LOADED FIREARM!
HIGH PRESSURE SPRAY CAN CAUSE EXTREMELY
SERIOUS INJURY. OBSERVE ALL WARNINGS!**

MANUAL NOTATIONS

WARNING - Alerts user to avoid or correct conditions that could cause bodily injury.

CAUTION - Alerts user to avoid or correct conditions that could cause damage to or destruction of equipment.

IMPORTANT - Alerts users to steps or procedures that are essential to proper equipment repair and maintenance.

NOTE - Identifies essential procedures or extra information.

BEFORE OPERATING THIS UNIT, READ AND FOLLOW ALL SAFETY WARNINGS AND INSTRUCTIONS RELATED TO THE USAGE OF THIS EQUIPMENT ON PAGES 2, 3 & 4. READ, LEARN, AND FOLLOW THE PRESSURE RELIEF PROCEDURE ON PAGE 8 OF THIS MANUAL.

All Service Procedures to be performed by an Authorized Airlessco Service Center **ONLY**.
NO MODIFICATIONS or alterations of any **AIRLESSCO** Equipment or part is allowed.

WARNINGS

MEDICAL ALERT - Airless Spray Wounds

If any fluid appears to penetrate your skin, get **EMERGENCY MEDICAL CARE AT ONCE. DO NOT TREAT AS A SIMPLE CUT.** Tell the doctor exactly what fluid was injected. Have him read the following "NOTE TO PHYSICIAN".

NOTE TO PHYSICIAN: Injection in the skin is a traumatic injury. It is important to treat the injury surgically as soon as possible. **DO NOT DELAY** treatment to research toxicity. Toxicity is a concern with some exotic coatings injected directly into the blood stream. Consultation with a plastic surgeon or reconstructive hand surgeon may be advisable.

WARNING

HIGH PRESSURE SPRAY CAN CAUSE EXTREMELY SERIOUS INJURY. OBSERVE ALL WARNINGS. THIS SPRAYER IS FOR PROFESSIONAL USE ONLY.

INJECTION HAZARD

FLUIDS UNDER HIGH PRESSURE FROM SPRAY OR LEAKS CAN PENETRATE THE SKIN AND CAUSE EXTREMELY SERIOUS INJURY, INCLUDING THE NEED FOR AMPUTATION.

NEVER point the spray gun towards anyone or at any part of the body.

NEVER put hand or fingers over the spray tip. Do not use rag or other materials over your fingers. Paint will penetrate through material and into the hand.

NEVER try to stop or deflect leaks with your hand or body.

ALWAYS have gun tip guard in place when spraying.

ALWAYS lock gun trigger when you stop spraying.

ALWAYS remove tip from the gun to clean it.

NEVER try to "blow back" paint, it's not an air sprayer.

ALWAYS follow the **PRESSURE RELIEF PROCEDURE**, as shown on page 8, before cleaning or removing the spray tip or servicing any system equipment.

Be sure equipment safety devices are operating properly before each use.

ALWAYS tighten all fluid connections before each use.

MEDICAL TREATMENT

If any fluid appears to penetrate your skin, get **EMERGENCY CARE AT ONCE.**

DO NOT TREAT AS A SIMPLE CUT.

- Go to an emergency room immediately.
- Tell the doctor you suspect an injection injury.
- Tell him what kind of material you were spraying with and have him read **NOTE TO PHYSICIAN** above.

GENERAL PRECAUTION

NEVER alter equipment in any manner.

NEVER smoke while in spraying area.

NEVER spray highly flammable materials.

NEVER use around children.

NEVER allow another person to use sprayer unless he is thoroughly instructed on its' safe use and given this operators manual to read.

ALWAYS wear a spray mask, gloves and protective eye wear while spraying.

ALWAYS ensure fire extinguishing equipment is readily available and properly maintained.

NEVER LEAVE SPRAYER UNATTENDED WITH PRESSURE IN THE SYSTEM. FOLLOW PRESSURE RELIEF PROCEDURES ON PAGE 8.

ALWAYS INSPECT SPRAYING AREA

Keep spraying area free from obstructions.

Make sure area has good ventilation to safely remove vapors. **NEVER** keep flammable material in spraying area. **NEVER** spray in vicinity of open flame or other sources of ignition. Spraying area must be at least 20 ft. away from spray unit.

SPRAY GUN SAFETY

ALWAYS set safety lock on the gun in "**LOCKED**" position when not in use and before servicing or cleaning.

DO NOT remove or modify any part of gun.

ALWAYS remove spray tip when cleaning.

Flush unit with **LOWEST POSSIBLE PRESSURE.**

CHECK operation of all gun safety devices before each use. Be very careful when removing the spray tip or hose from gun. A plugged line contains fluid under pressure. If the tip or line is plugged, follow the **PRESSURE RELIEF PROCEDURE** as outlined on page 8.

TIP GUARD

ALWAYS have the tip guard in place on the spray gun while spraying. The tip guard alerts you to the injection hazard and helps prevent accidentally placing your fingers or any part of your body close to the spray tip.

SPRAY TIP SAFETY

USE EXTREME CAUTION when cleaning or changing spray tips. If the spray tip clogs while spraying, engage the gun safety latch immediately.

ALWAYS follow the **PRESSURE RELIEF PROCEDURE** before removing the spray tip to clean it.

NEVER wipe off build up around the spray tip.

ALWAYS remove tip & tip guard to clean **AFTER** pump is turned off and the pressure is relieved by following the **PRESSURE RELIEF PROCEDURE.**

WARNINGS CONTINUED ON NEXT PAGE.....

WARNINGS - CONTINUED

ALWAYS INSPECT SPRAYING AREA

Keep clear of moving parts when starting or operating the sprayer. Do not put your fingers into any openings to avoid amputation by moving parts or burns on hot parts. Precaution is the best insurance against an accident.

When starting the engine, maintain a safe distance from moving parts of the equipment.

Before adjusting or servicing any mechanical part of the sprayer, follow the **PRESSURE RELIEF PROCEDURE** on page 8, and remove the ignition cable from the spark plug to prevent accidental starting of sprayer.

HOSES

Tighten all fluid connections securely before each use. High pressure fluid can dislodge a loose coupling or allow high pressure spray to be emitted from the coupling and result in an injection injury or serious bodily injury.

Use only hose that has a spring guard. The spring guard helps protect the hose from kinks or other damage which could result in hose rupture and cause an injection injury.

NEVER use a damaged hose, which can result in hose failure or rupture and cause in injection injury or other serious bodily injury or bodily damage. Before each use, check entire hose for cuts, leaks, abrasion or bulging of cover, or damage or movement of couplings. If any of these conditions exist, replace the hose immediately. Never use tape or any device to try to mend the hose as it cannot contain the high pressure fluid. **NEVER ATTEMPT TO RECOUPLE THE HOSE.** High pressure hose is not recoupleable.

Help prevent damage to the hose by handling and routing it carefully. Do not move the sprayer by pulling it with the hose.

LABELING

Keep all labels on the unit clean and readable. Replacement labels are available from manufacturer.

TOXIC FLUID HAZARD

Hazardous fluid or toxic fumes can cause serious injury or death if splashed in eyes or on skin, inhaled or swallowed. Know the hazards of the fluid you are using. Store & dispose of hazardous fluids according to manufacturer, local, state & national guidelines.

ALWAYS wear protective eyewear, gloves, clothing and respirator as recommended by fluid manufacturer.

GROUNDING

Ground the sprayer and other components in the system to reduce the risk of static sparking, fire or explosion which can result in serious bodily injury and property damage.

ALWAYS GROUND ALL OF THESE COMPONENTS:

1. Sprayer: Connect a ground wire and clamp (supplied) to a true earth ground.
2. Fluid Hose: use only grounded hoses.
3. Spray gun or dispensing valve: grounding is obtained through connection to a properly grounded fluid hose and pump.
4. Object being sprayed: according to your local code.
5. All solvent pails used when flushing should only be metal pails which are conductive.

Once each week, check electrical resistance of hose (when using multiple hose assemblies, check overall resistance of unpressurized hose must not exceed 29 megohms (max) for any coupled length or combination of hose lengths. If hose exceeds these limits, replace it immediately.

Never exceed 500 Ft. (150 m.) overall combined hose length to assure electrical continuity.

WARNINGS CONTINUED ON NEXT PAGE.....

WARNINGS - CONTINUED

AVOID COMPONENT RUPTURE

This sprayer operates at 3000 psi (205 bar). **ALWAYS** be sure that all components and accessories have a maximum working pressure of at least 3000 psi to avoid rupture which can result in serious bodily injury including injection and property damage.

NEVER leave a pressurized sprayer unattended to avoid accidental operation of it which could result in serious bodily injury.

ALWAYS follow the **PRESSURE RELIEF PROCEDURE** whenever you stop spraying and before adjusting, removing or repairing any part of the sprayer.

NEVER alter or modify any part of the equipment to avoid possible component rupture which could result in serious bodily injury and property damage.

NEVER use weak or damaged or non-conductive paint hose. Do not allow kinking or crushing of hoses or allow it to vibrate against rough or sharp or hot surfaces. Before each use, check hoses for damage and wear and ensure all fluid connections are secure.

REPLACE any damaged hose. **NEVER** use tape or any device to mend the hose.

NEVER attempt to stop any leakage in the line or fittings with your hand or any part of the body. Turn off the unit and release pressure by following **PRESSURE RELIEF PROCEDURE**.

ALWAYS use approved high pressure fittings and replacement parts.

ALWAYS ensure fire extinguishing equipment is readily available and properly maintained.

WARNING

Do not use halogenated solvents in this system. The prime valve, 2 gun manifold and most airless guns have aluminum parts and may explode. Cleaning agents, coatings, paints or adhesives may contain halogenated hydrocarbon solvents. **DON'T TAKE CHANCES!** Consult your material suppliers to be sure. Some of the most common of these solvents are: Carbontetrachloride, Chlorobenzene, Dichloroethane, Dichloroethyl Ether, Ethylbromide, Ethylchloride, Tetrachloroethane. Alternate valves and guns are available if you need to use these solvents.

PREVENT STATIC SPARKED FIRE/ EXPLOSIONS

ALWAYS be sure all equipment and objects being sprayed are properly grounded. **ALWAYS** ground sprayer, paint bucket and object being sprayed. See "grounding" on page 3 for detailed grounding information.

Vapors created when spraying can be ignited by sparks. To reduce the risk of fire, always locate the sprayer at least 20 feet (6 m.) away from the spray area. **DO NOT** plug in or unplug any electrical cords in the spray area, which can create sparks, when there is any chance of igniting vapors still in the air. Follow the coating & solvent manufacturers safety warnings and precautions.

Use only conductive fluid hoses for airless applications. Be sure gun is grounded through hose connections. Check ground continuity in hose & equipment. Overall (end to end) resistance of unpressurized hose must not exceed 29 megohms for any coupled length or combination of hose length. Use only high pressure airless hoses with static wire approved for 3000 psi.

FLUSHING

Reduce the risk of injection injury, static sparking or splashing by following the specific cleaning procedure on page 6 and 8.

ALWAYS follow the **PRESSURE RELIEF PROCEDURE** on page 8.

ALWAYS remove the spray tip before flushing. Hold a metal part of the gun firmly to the side of a metal pail and use the lowest possible fluid pressure during flushing.

NEVER use cleaning solvents with flash points below 140 degrees F. Some of these are: acetone, benzene, ether, gasoline, naphtha. Consult your supplier to be sure.

NEVER SMOKE IN THE SPRAYING/CLEANING AREA.

GAS ENGINE PRECAUTIONS

Place unit 25 feet away from spraying in ventilated area.

NEVER operate in buildings unless exhaust is piped outside.

NEVER allow hose to lay against engine mufflers or hot parts.

NEVER refill fuel tank while engine is hot or is running.

IMPORTANT: United States Government safety standards have been adopted under the Occupational Safety & Health Act. These standards, particularly the General Standards, Part 1910, & the Construction Standards, part 1926 should be consulted.

WHEN SPRAYING & CLEANING WITH FLAMMABLE PAINTS OR THINNERS:

1. When spraying with flammable liquids, the unit must be located a minimum of 25 feet away from the spraying area in a well ventilated area. Ventilation must be sufficient enough to prevent the accumulation of vapors.
2. To eliminate electrostatic discharge, ground the spray unit, paint bucket and spraying object. Use only high pressure airless hoses approved for 3000 psi which is conductive.
3. Remove spray tip before cleaning gun and hose. Make contact of gun with bucket and spray without the tip in a well ventilated area, into the grounded steel bucket.
4. Never use high pressure in the cleaning process. **USE MINIMUM PRESSURE.**
5. Do not smoke in spraying/cleaning area.

SETTING UP

1. CONNECT THE HOSE AND GUN

- Remove the plastic cap plug from the outlet and screw a conductive or grounded 3000 psi spray hose onto fluid outlet.
- Connect an airless spray gun to the other end of the hose, but do not install the spray tip yet!

NOTE: Do not use thread sealer on swivel unions as they are made to self seal.

NOTE: The 6' whip hose should always be 3/8".

2. FILL THE PACKING NUT/WET CUP

Fill the Packing Nut/Wet Cup 1/3 full with Airlessco Throat Seal Oil (TSO). **FIG 1 BELOW.**

FIG. 1

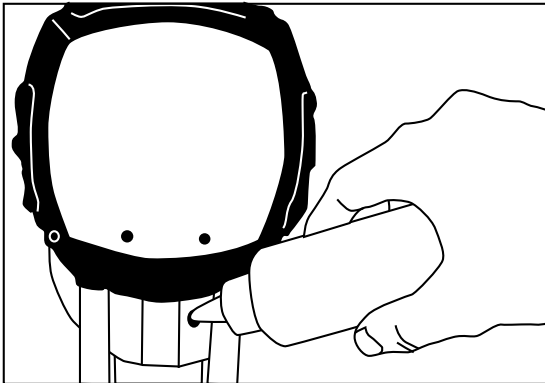

3. CHECK THE ENGINE OIL LEVEL

- Unscrew the oil fill plug. The dipstick is attached to the plug.
- Without threading the plug into place, check to be sure the oil is up to the top mark on the dipstick.
- If oil is needed, refer to engine manual.

4. FILL THE FUEL TANK

WARNING: Fuel spilled on a hot surface can cause a fire or explosion and cause serious bodily injury and property damage. Always shut off the engine and let it cool before filling the tank, and carefully follow steps a - c below being sure not to spill any fuel.

- Close the fuel shutoff valve.
- Use only clean, fresh, well-known brands of unleaded regular grade gasoline.
- Remove the fuel cap and fill tank. Be sure the air vent in the fill cap is not plugged so fuel can flow to the carburetor, then replace the cap.

5. FLUSH THE SPRAYER

- Flush sprayer per instructions below.

FLUSHING

1. NEW SPRAYER

Your unit was factory tested in an anti-freeze solution which was left in the pump. Before using oil-base paint, flush with mineral spirits only.

Before using water-base paint flush with mineral spirits, followed by soapy water, then a clean water flush.

2. CHANGING COLORS

Flush with a compatible solvent such as mineral spirits or water.

3. CHANGING FROM WATER-BASE TO OIL-BASE PAINT

Flush with soapy water, then mineral spirits.

4. CHANGING FROM OIL-BASE TO WATER-BASE PAINT

Flush with mineral spirits, followed by soapy water, then a clean water flush.

5. STORAGE

Oil-base paint: Flush with mineral spirits.

Water-base paint: Flush with water, then mineral spirits and leave the pump, hose and gun filled with mineral spirits.

For longer storage, use mixture of mineral spirits and motor oil (half & half). Shut off the sprayer, follow **PRESSURE RELIEF PROCEDURE** on page 8 to relieve pressure and make sure prime valve is left open.

6. START UP AFTER STORAGE

Before using water-base paint, flush with soapy water and then a clean water flush.

When using oil-base paint, flush out the mineral spirits with the material to be sprayed.

HOW TO FLUSH

1. Be sure the gun safety latch is engaged and there is no spray tip in the gun. Refer to Fig. 2. Refer to your separate instruction manual provided with your gun on its safety features and how to engage safety latch.
2. Pour enough clean, compatible solvent into a large, empty metal pail to fill the pump and hoses.
3. Place the suction tube into the pail or place the pail under the pump.
4. Turn the Control Valve to low/prime position (counter clockwise). This will allow an easy start Refer to Fig. 3.
5. Turn the engine ON/OFF switch to ON.
6. Move the choke toward the closed position as per Fig.4.
7. Move the throttle lever slightly to the left as per Fig.4.
8. Turn the fuel valve ON as per Fig. 4. Pull the start rope. Pull the engine over against compression stroke and then let the rope rewind slowly into the starter. Pull firmly and rapidly to start the engine. Do NOT drop the rope. Hold on to the handle while rewinding, or the rope may rewind improperly and jam the assembly. If the engine does not start, open the choke a little more. If the engine floods, open the choke all the way and continue cranking.
9. After the engine is warm, gradually close the choke, raise the RPM of engine slightly by moving throttle to the left. Unit will start to prime. Refer to Fig. 3
10. Point the gun into the metal pail and hold a metal part of the gun firmly against the pail Refer to fig. 5.
11. Disengage the gun safety latch and squeeze the gun trigger. At the same time, slowly turn the pressure control valve knob clockwise just enough to move liquid at low pressure.
12. Allow the pump to operate until clean solvent comes from the gun.
13. Release the trigger and engage the gun safety latch.
14. If you are going to start spraying, place the pump or suction tube into the supply container. Release the gun safety latch and trigger the gun into another empty, metal container, holding a metal part of the gun firmly against the metal pail (Fig. 5), forcing the solvent from the pump and hose. When paint starts coming from gun, turn control valve to minimum pressure, and engage the gun safety latch.
15. If you are going to store the sprayer, remove the suction tube or pump from the solvent pail force the solvent from the pump and hose. Engage the gun safety latch and refer to the "Storage" Procedure on page 5. Step 5.
16. Whenever you shut off the sprayer follow the **PRESSURE RELIEF PROCEDURE** warning on page 8.

FIG. 2

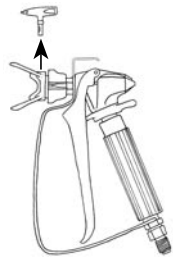

REMOVE SPRAY TIP. ENGAGE GUN SAFETY LATCH.

FIG. 3

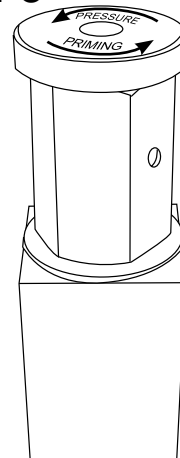

FIG. 4

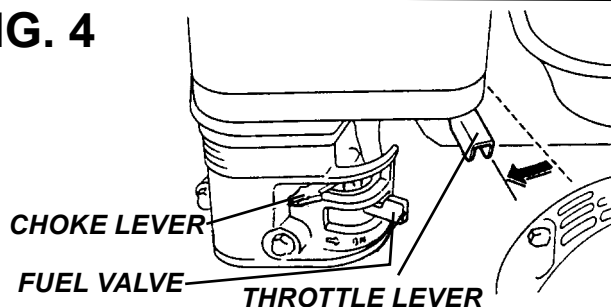
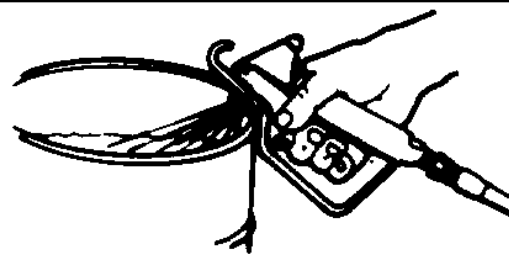

FIG. 5

MAINTAIN FIRM METAL TO METAL CONTACT BETWEEN GUN AND CONTAINER



WARNING: To reduce the risk of static sparking, which can cause fire or explosion, always hold a metal part of the gun firmly against the metal pail when flushing. This also reduces splashing. Refer to Fig 6.

STARTING UP

1. LEARN HOW TO OPERATE THE CONTROL VALVE

The control valve sets the prime or pressure position as well as the spraying pressure. When the valve is fully counter-clockwise the unit is in the prime position. As the control valve is turned clockwise, the unit's output pressure to the gun is gradually increased until the control valve is fully clockwise and the unit is at its maximum output pressure of 1500 psi. This will fully atomize any stain or paint without needing to dilute the material.



FOLLOW "PRESSURE RELIEF PROCEDURES" ON PAGE 8 WHENEVER YOU:

- are instructed to relieve pressure
- stop spraying
- checking or servicing any of the system equipment.
- install or clean the spray tip.

2. PREPARE THE MATERIAL

- Prepare the material according to the material manufacturer's recommendations.
- Place the suction tube into the material container.

3. STARTING THE SPRAYER

- Control Valve must be "OPEN" in the priming position.
- When you have ensured that the gun safety latch is engaged, attach tip and safety guard.
- Turn the engine ON/OFF switch to the "ON" position. Pull rope vigorously until engine starts.
- After the pump is primed, turn Control Valve to clockwise start building pressure. Continue turning the Control valve to set the desired spray pressure.
- Disengage the gun safety latch and you are ready to spray.

4. ADJUSTING THE PRESSURE

- Turn the Control Valve clockwise to increase pressure and counterclockwise to decrease pressure.
- Always use the lowest pressure necessary to completely atomize the material.

NOTE: OPERATING THE SPRAYER AT HIGHER PRESSURE THAN NEEDED, WASTES MATERIAL, CAUSES EARLY TIP WEAR, AND SHORTENS SPRAYER LIFE.

- If more coverage is needed, use a larger tip rather than increasing the pressure.
- Check the spray pattern. The tip size and angle determines the pattern width and flow rate.

WARNING

FOLLOW THE "PRESSURE RELIEF PROCEDURE".

To reduce the risk of injection, never hold your hand, body, fingers or hand in a rag in front of the spray tip when cleaning or checking for a cleared tip. Always point the gun toward the ground or into a waste container when checking to see if the tip is cleared or when using a self-cleaning tip.

WARNING

When you spray into the paint bucket, always use the lowest spray pressure and maintain firm metal to metal contact between gun and container.

WARNING

To stop the unit in an emergency, turn the engine off. Then relieve the fluid pressure in the pump and hose as instructed in the **PRESSURE RELIEF PROCEDURE**.

5. WHEN SHUTTING OFF THE SPRAYER

- Whenever you stop spraying, even for a short break, follow the "Pressure Relief Procedure".
- Clean the tip & gun as recommended in the separate Gun Manual supplied with the gun.
- Flush the sprayer at the end of each work day, if the material you are spraying is water-based, or if it could harden in the sprayer overnight. See "Flushing". Use a compatible solvent to flush, then fill the pump and hoses with an oil based solvent such as mineral spirits.
- For long term shutdown or storage, refer to the "Flushing" section of this manual.

WARNING

Be sure to relieve pressure in the pump after filling with Airlessco Pump Conditioner.

AVOIDING TIP CLOGS

There is an easy way to keep the outside of the tip clean from material build up:

Every time you stop spraying, for even a minute, lock the gun and submerge it into a small bucket of thinner suitable for the material sprayed.

Thinner will dissolve the buildup of paint on the outside of tip, tip guard and gun much more effectively if the paint doesn't have time to dry out completely.

PRESSURE RELIEF PROCEDURE



IMPORTANT!

TO AVOID POSSIBLE SERIOUS BODY INJURY, ALWAYS FOLLOW THIS PROCEDURE WHENEVER THE SPRAYER IS SHUT OFF, WHEN CHECKING IT, WHEN INSTALLING, CHANGING OR CLEANING TIPS, WHENEVER YOU STOP SPRAYING, OR WHEN YOU ARE INSTRUCTED TO RELIEVE THE PRESSURE.

1. Engage the gun safety latch. Refer to the separate instruction manual provided with your gun on its safety features and how to engage safety latch.
2. Turn the unit off.
3. Disengage the gun safety latch and trigger the gun to relieve residual fluid pressure.
4. Re-engage gun safety latch.
5. Turn Control Valve (Prime/Pressure Relief Valve) as shown open (priming) to relieve fluid pressure.

HOLD METAL PART OF THE GUN IN CONTACT WITH GROUNDED METAL PAIL. USE MINIMUM PRESSURE !

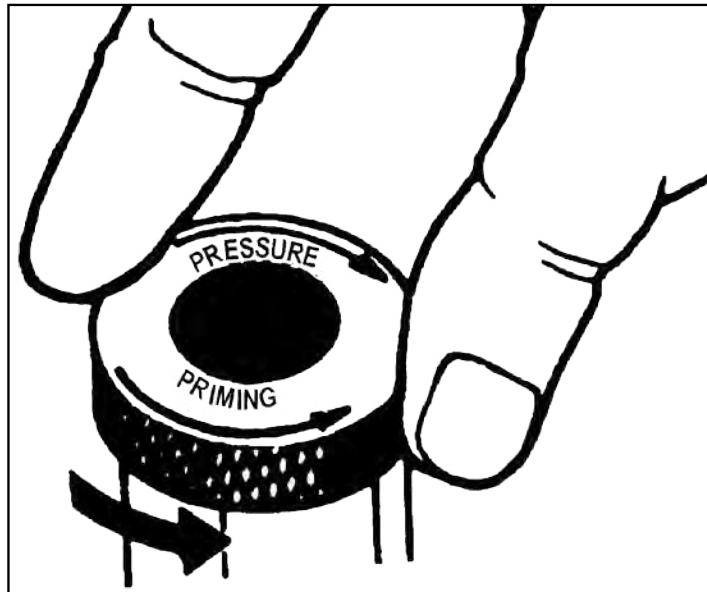
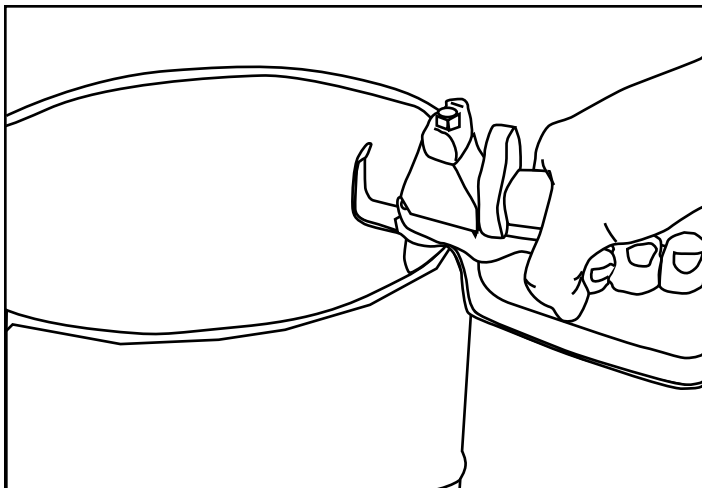

DAILY MAINTENANCE

1. Always stop the pump at the bottom of its stroke when you take a break or at the end of the day. This helps keep material from drying on the rod, damaging the packings.
2. Keep the displacement pump packing nut/wet cup 1/3 full of Airlessco Throat Seal Oil at all times. The TSO helps protect the packings and rod.
3. Lubricate Connecting Rod Pin every 3 months.
4. Inspect the packing nut daily. Your paint pump has Airlessco's patented "Triple Life Packing System". Packing life will be extended a minimum of 3 times if the proper packing tightening procedure is followed!

PACKING TIGHTENING PROCEDURE:

Inspect the packing nut daily! If seepage of paint into the packing nut and/ or movement of the piston upward is found (while not spraying), the packing nut should be tightened enough to stop leakage only, but not any tighter. **OVERTIGHTENING WILL DAMAGE THE PACKINGS** and reduce the packing life to the life of other piston pumps.

LINE STRIPING OPERATION

1. CHOOSE THE GUN ARM POSITION

There is a hole in each corner of the striper frame, in which the gun arm can be mounted. In a standard set up, the gun arm would be mounted in the right hand near the single wheel. This allows for an easier visual check for straight line striping and for basic arc striping.

2. SETTING UP THE GUN

- a. Ensure that a striping tip is in the gun.
- b. Pick a tip size for the desired line width.
EXAMPLE: a 317ST tip for a four inch line.
- c. Place gun into the gun holder, so that the top of the taper on the gun handle is flush with the edge of the gun holder.
- d. Set gun height for the desired line width. Adjust height by loosening the small black handle on the gun holder assembly and slide the gun arm to the correct height. Now tighten the handle. This will require some experimentation to find the correct height. It is suggested that tape, or some other method is used to mark the height of commonly used settings.
- e. Attach the swivel heads to the gun if painting curbs or wide stripes.
- f. Angle the gun slightly forward. This allows the spray pressure from the guns to help blow dirt and debris out of the path of the new stripes.

3. CABLE TENSION ADJUSTMENT

Once the handle and gun arm assembly is set up to the preferred position, pressurize the unit and trigger the gun to ensure that it activates and releases correctly. If not, adjust the cable tension as follows:

- a. Locate the adjustment knobs on the base of the gun trigger, where the cable connects to the gun trigger assembly.
- b. Loose the locking nut and move the adjusting screw until the slack has been removed from the cable.
- c. Tighten locking nut and retest gun trigger for proper function.

NOTE: THERE IS AN ADDITIONAL CABLE ADJUSTMENT WHERE THE CABLE ATTACHES TO THE GUN HOLDER ASSEMBLY. USE ONLY IF THE GUN TRIGGER ADJUSTMENT IS INSUFFICIENT.

4. MISCELLANEOUS OPERATIONS

- a. **CURBS:** Adjust gun to desired height and turn swivel head towards curb.
- b. **WIDE STRIPES:** Install wider fan striping tips and raise the gun height to achieve the desired width line.
- c. **STENCILS:** Install standard spray tip on the gun. Remove this gun from the gun holder and spray out the stencils. A second gun and hose can be attached and bolted with a ball valve for stencils.
- d. **STANDARD PAINTING:** Same as stencils, but use additional paint hose as required.

AIRLESS SPRAY GUN OPERATION

SPRAY

Attach spray gun to airless unit and tighten fittings securely. Set the gun safety latch. (Also may be called gun safety lock, or trigger lock)

* The gun safety latch should always be set when the gun is not being triggered.

Read all warnings and safety precautions supplied with the spray gun and in product manual.

FIG. 6

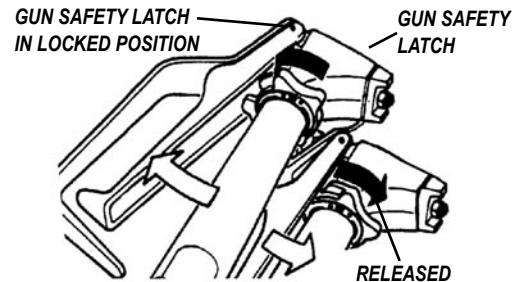

MAJOR COMPONENTS OF SPRAY GUN AND REVERSIBLE SPRAY TIP

FIG. 7

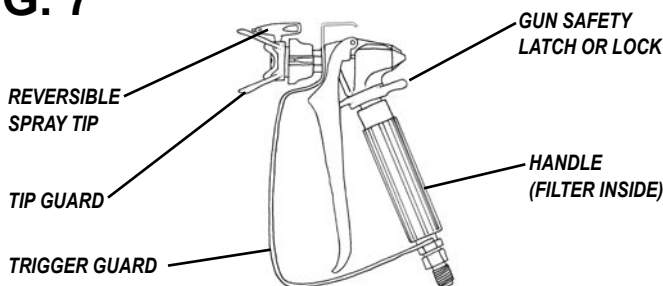
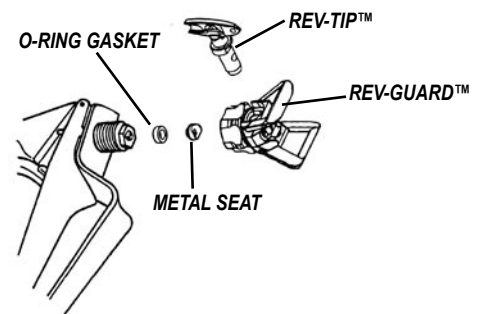

FIG. 8



SPRAY TIP ASSEMBLY

1. Be sure pressure relief procedure is followed before assembling tip and housing to the gun.
2. Lock gun safety latch.
3. Insert REV-TIP™ cylinder into the REV-GUARD™ (guard housing assembly).
4. Guide metal seat into REV-GUARD™ (guard housing assembly) through retaining nut & turn until it seats against the cylinder.
5. Insert O-Ring gasket on metal seat so it fits in the grooves.
6. Finger tighten REV-GUARD™ retaining nut onto the gun.
7. Turn guard in the desired position.
8. Completely tighten the retaining nut.

FIG. 9

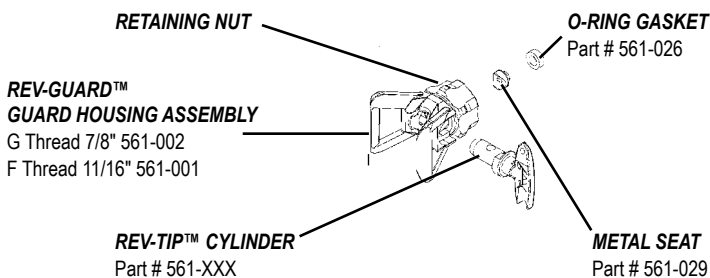

CLEANING SPRAY GUN

Immediately after the work is finished, flush the gun out with a solvent. Brush pins with solvent and oil them lightly so they will not collect dried paint.

CLEANING FILTER IN GUN HANDLE

To clean the filter, use a brush dipped in an appropriate solvent. Change or clean filters at least once a day. Some types of latex may require a filter change after four hours of operation.

TO REMOVE CLOGS FROM SPRAY TIP

1. Lock gun safety latch.
2. Turn REV-TIP™ handle 180 degrees.
3. Disengage trigger lock & trigger gun into pail.
4. If the REV-TIP™ handle appears locked (resists turning), loosen the retaining nut. The handle will now turn easily.
5. Engage gun safety latch & return handle to the spray position.

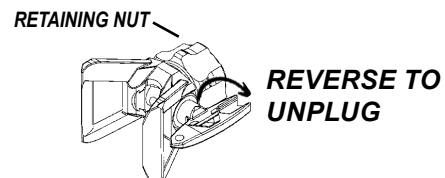

Spray Position Shown

CLOGGED FLAT TIP

Should the spray tip become clogged, relieve pressure from hose by following the "Pressure Relief Procedure." Secure gun with the safety latch, take off guard, take out the tip, soak in appropriate solvent & clean with a brush. (Do not use a needle or sharp pointed instrument to clean the tip. The tungsten carbide is brittle and can chip.)

AIRLESS SPRAY GUN

FIG. 10

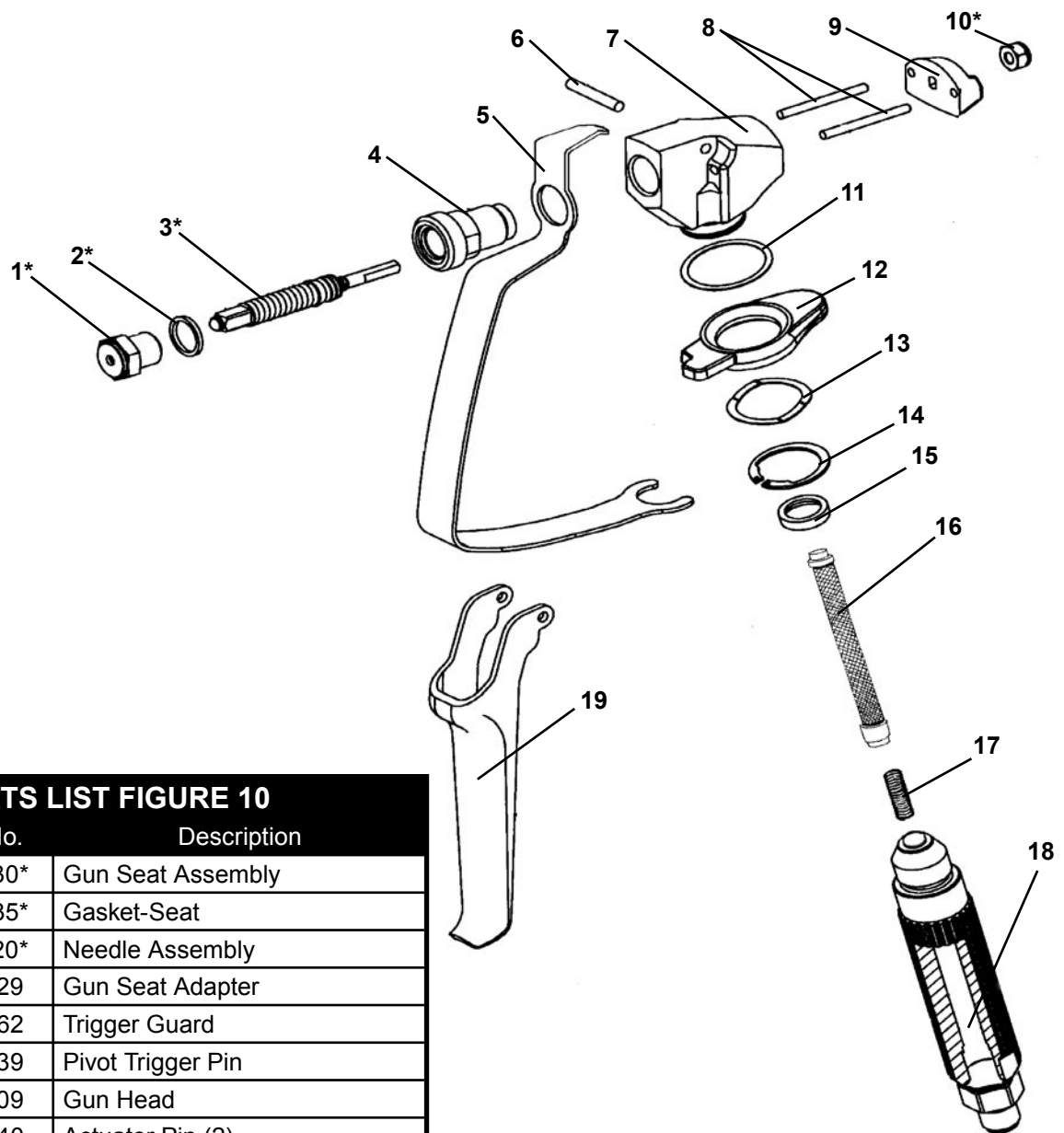

PARTS LIST FIGURE 10

Item No.	Part No.	Description
1	120-530*	Gun Seat Assembly
2	120-535*	Gasket-Seat
3	120-520*	Needle Assembly
4	120-529	Gun Seat Adapter
5	120-562	Trigger Guard
6	120-539	Pivot Trigger Pin
7	120-509	Gun Head
8	120-540	Actuator Pin (2)
9	120-536	Gun Plate
10	120-038*	Nut
11	120-056	Plastic Washer
12	120-538	Gun Trigger Lock
13	120-055	Wave Washer
14	120-049	Retaining Ring
15	120-082	Handle Seal
16	120-090CX	Gun Filter-Coarse
	120-090FX	Gun Filter-Fine
17	120-088	Spring
18	120-099	Gun Handle Assembly
19	120-506	Gun Trigger
*	120-534	Gun Repair Kit

AIRLESS SPRAY TROUBLESHOOTING

DEFECTS	CAUSE	CORRECTION
Coarse spray	Low pressure	Increase the pressure
Excessive fogging (overspray)	High pressure Material too thin	Reduce the pressure to satisfactory pattern distribution Use less thinner
Pattern too wide	Spray angle too large	Use smaller spray angle tip
Pattern too narrow	Spray angle too small	use larger spray angle tip (if coverage is OK, try tip in same nozzle group)
Too much material	Nozzle too large Material too thin Pressure too high	Use smaller nozzle Reduce pressure
Too little material	Nozzle too small	Use next larger nozzle Material too thick
Thin distribution in center of pattern "horns"	Worn tip Wrong tip	Change to new tip Use nozzle with narrow spray angle
Thick skin on work	Material too viscous Application too heavy	Thin cautiously Reduce pressure and/or use tip in next smaller nozzle group
Coating fails to close & smooth over	Material too viscous	Thin cautiously
Spray pattern irregular, deflected	Orifice clogged Tip damaged	Clean carefully Replace with new tip
Craters or pock marks, bubbles on work	Solvent balance	Use 1 to 3% "short solvents remainder "long" solvents (this is most likely to happen with material of low viscosity, lacquers, etc.)
Clogged screens	Extraneous material in paint Course pigments Poorly milled pigments (paint pigments glocculate)	Clean screen Use coarse screen if orifice size allows. Use courser screen, larger orifice tips. Obtain ball milled paint. If thinner has been added, test to see if a cover screen. Incompatible drop placed on top of paint mixes or flattens out on the paint mixture & thinners on the surface. If not, try different thinner in fresh batch of paint.

TEST THE PATTERN

GOOD, FULL



SPOTTY PATTERN, INCREASE PRESSURE



LINE STRIPING TIP CHART

NOTE: STRIPING TIPS SHOULD NOT BE USED FOR REGULAR SPRAYING.

REV-TIP™ for Striping, Part Number 562-xxxST

TIP IDENTIFICATION

- 1st 3-digits identifies it as a **REV-TIP™** for airless line striping (Part Number 562-xxxST).
- 4th digit is the fan width - the number is half the fan width, e.g., 2 means a 4" line width.
- 5th and 6th digits are for the orifice size and is measured in thousandths of an inch, e.g., 17 = 0.017 inch.

The higher the number, the larger the tip.

REVERSIBLE STRIPING TIP SIZE CHART

REV-TIP™ FOR STRIPING 562-XXXST

FAN WIDTH (6" FROM SURFACE)		ORIFICE SIZE (INCHES)				
INCHES	MILLIMETERS	.013	.015	.017	.019	.021
1-2	25-51	113ST	115ST	117ST		
2-4	51-102		215ST	217ST	219ST	221ST
4-6	102-152		315ST	317ST	319ST	321ST
6-8	152-203		415ST	417ST	419ST	421ST
Striping paint		Oil Base	Oil Base	Latex	Latex	Latex

REV-TIP™ protected By U.S. Patent No. 6,264,115. Other U.S. & foreign patents applied for.

TIP REPLACEMENT

During use, high pressure will cause the orifice to grow larger. This destroys the pattern or will leave tailing or two heavy lines on the outside of the pattern. **REPLACE SPRAY TIP FREQUENTLY!**

FIELD TROUBLESHOOTING

PROBLEM	CAUSE	SOLUTION
Unit doesn't prime	Airleak due to: <ul style="list-style-type: none"> • Loose suction nut • Worn o-rings • Hole in suction hose Stuck or fouled balls	<ul style="list-style-type: none"> • tighten suction nut • replace o-ring (106-011) on suction seat & o-ring (106-020) below suction seat • replace suction hose (331-290) • service outlet valve suction assembly
Unit primes but has poor or no pressure	Pressure set too low Filter(s) are clogged Outlet valve fouled/worn Control valve bypassing excessively* Packings and/or piston worn	<ul style="list-style-type: none"> • turn up pressure • clean or replace gun filter, inlet filter, and/or manifold filter • service outlet valve • clean or replace control valve • tighten packing nut • repack unit
Unit does not maintain good spraying pressure	Blown spray tip Packings and/or pistons worn Upper seat worn	<ul style="list-style-type: none"> • replace spray tip • repack unit • replace upper seat

***NOTE: THE CONTROL VALVE WILL ALWAYS BE BYPASSING WHEN THE UNIT IS BUILDING MORE PRESSURE THAN IS BEING RELEASED BY THE GUN.**

SERVICING THE FLUID PUMP

FLUID PUMP DISCONNECT

REFER TO FIGURE 11

1. Follow the Pressure Relief Procedure on page 8.
2. Flush the material you are spraying out of the machine.
3. Remove the connecting rod shield.
4. Move the piston rod to its lowest position by cycling pump slowly.
5. Turn off the motor.
6. Disconnect fluid hose from fluid pump.
7. Remove the retaining ring from the connecting rod and slide the sleeve down revealing the connecting rod pin.
8. Remove the suction tube assembly from the fluid pump by unscrewing the suction nut with the packing adjustment tool (189-211).
9. Using a 1/2" wrench unscrew the two bolts from the cover assembly. The fluid pump will be hanging loosely at this point.
10. Remove the connecting rod pin out of the connecting rod, allowing the removal of the fluid pump from the machine.

FLUID PUMP REINSTALL

REFER TO FIGURES 11 & 13

1. Loosen the packing nut and ensure that the piston rod is in its upper position in the fluid pump body. Slip the sleeve & the retaining ring over the piston rod.
2. Push the piston rod up into the connecting rod & align the holes. Insert the connecting rod pin through the connecting rod & piston. Slip the sleeve up over the connecting rod pin and insert the retaining ring into the groove on the connecting rod.
3. Push the two bolts through the tube spacers & screw them into the cover assembly. Using a 1/2" wrench, tighten the two bolts evenly (alternating between them) until you reach 20 ft-lbs.
4. Reassemble lower suction valve assembly by placing the suction seat, O-ring, suction ball & suction ball guide in the suction nut & screw onto fluid pump body.
5. Reconnect fluid hose to fluid pump.
6. Start the machine and operate slowly to check the piston rod for binding. Adjust the two bolts, holding the fluid pump body to the cover assembly, if necessary. This will eliminate any binding.
7. Tighten packing nut clockwise until resistance is felt against the Belleville Springs, go 3/4 of a turn more. Put five drops of Airlessco Throat Seal Oil in the packing nut.
8. Run the machine at full pressure for several minutes. Release the pressure by following the Pressure Relief Procedure & readjust the packing nut per step 7 above.
9. Install the connecting rod shield so that the small hole is in the upper right hand corner.

FIG. 11

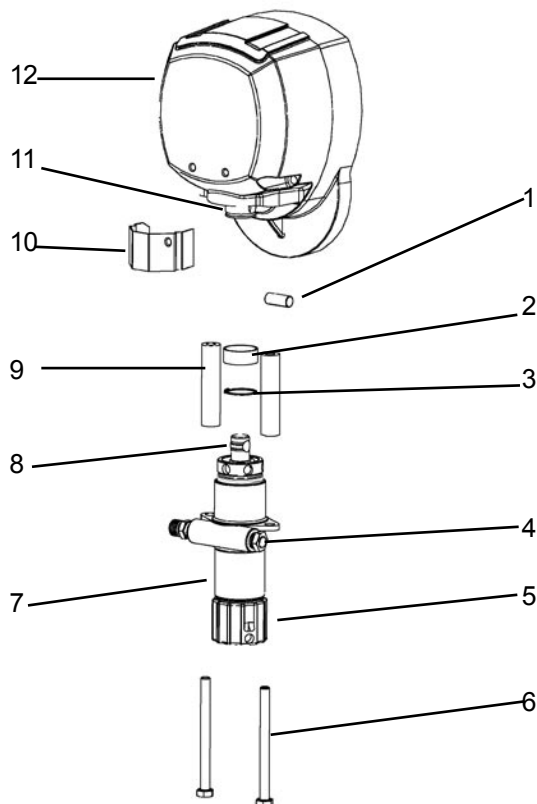

PARTS LIST FIGURE 11

Item No.	Part No.	Description
1	119-028	Connecting Rod Pin
2	331-117	Sleeve
3	331-062	Retaining Ring
4	115-019	Hose Connector
5	331-034	Suction Nut
6	100-318	Bolts
7	331-209	Fluid Pump
8	331-093	Piston Rod
9	331-074	Tube Spacers
10	331-111	Connection Rod Shield
11	331-038	Connecting Rod
12	331-537	Cover Assembly

SERVICING THE OUTLET VALVE

DISASSEMBLY OF THE OUTLET VALVE

1. Disconnect the Fluid Pump following instructions on page 14.
2. Place piston holder in a vise. Slide piston into the holder & lock in place with a 3/8" dowel.
3. Use a 1/4" allen wrench to unscrew the outlet seat retainer from the piston.
4. Remove the outlet seat, O-ring and outlet ball.
5. Inspect outlet ball & seat for wear. Replace as necessary. Ensure seat is right side up.
6. While piston is still locked in the holder, install parts back into the piston in the following order:

BALL, OUTLET SEAT AND O-RING

Before reinstalling the outlet seat support, apply two drops of Loctite No. 242 (blue) on the threads & torque to 20 ft-lbs.

NOTE: Airlessco LP pump tool kit 188-197 is required for this task. Kit includes: Tightening Bar (189-211), Packing Removal Tool (331-465), Piston Holder (331-195), 3/8" dowel (331-196).

FIG. 12

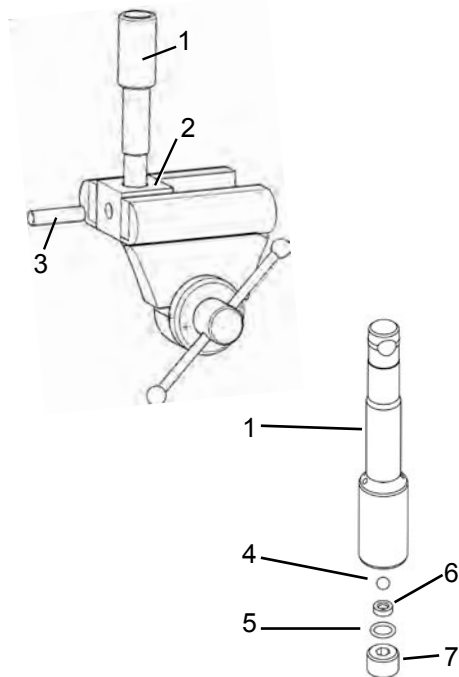

SERVICING THE INLET ASSEMBLY

1. Un-thread and remove suction nut from the fluid pump body.
2. Remove suction seat, O-ring, suction ball and suction retainer.
3. Clean all parts and inspect them for wear or damage, replacing parts as needed.
4. Clean inside of the fluid pump body.
5. Reassemble lower suction valve assembly by placing the suction seat, O-ring, suction ball & suction ball guide in the suction nut & screw onto fluid pump body.

FIG. 13

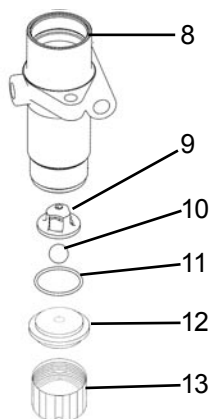

PARTS LIST FIGURE 12 & 13

Item No.	Part No.	Description
1	331-708	Piston
2	331-195	Piston Holder
3	331-196	Dowel Pin
4	331-027	Outlet Ball
5	331-100	O-Ring
6	331-026	Outlet Seat
7	331-314	Outlet Seat Retainer
8	331-011	Fluid Pump Body
9	331-029	Suction Ball Guide
10	331-030	Suction Ball
11	106-011	O-Ring
12	331-409	Suction Seat
13	331-034	Suction Nut

PACKING REPLACEMENT PROCEDURES











DISASSEMBLY OF THE FLUID PUMP

REFER TO FIGURE 14 & 15

1. Disconnect the Fluid Pump as instructed on page 14.
 2. Unscrew & remove the packing nut.
 3. Push the piston rod down through the packings & out of the pump.
 4. Now push the packing removal tool up through the pump & remove from the top bringing packings, spacer & springs along with it, leaving fluid body empty.
- *MAKE SURE ALL OLD PACKINGS & GLANDS HAVE BEEN REMOVED FROM FLUID PUMP.**
5. Clean inside of fluid body.
 6. Disassemble all parts & clean for reassembly. Discard any old packings.
 7. Lubricate leather packing in lightweight oil for 10 minutes prior to reassembly.

REASSEMBLY

REFER TO FIGURE 14

1. Take lower male gland & place it down on the flat side. 
2. Take three of the lower polyethylene packings & two of the leather packings & place onto the male gland in the following order with the inverted side down  **POLYETHYLENE, LEATHER, POLYETHYLENE, LEATHER, POLYETHYLENE.**
3. Take the female adaptor, which is inverted on both sides , & place it on top of your assembled lower packings.
4. Follow step 2 with your packings inverted side up. 
5. Take the second lower male gland and place it on top of your assembled packings with the rounded side down. 
6. Take assembled glands & packings (13 pieces) & slide onto the lower half of the piston.
7. Take the spacer & slide over the top of the piston (it doesn't matter which direction it sits, falling onto lower packings).
8. Take three Belleville Springs & slide over the top of the piston in the following order:
 - First spring, curve facing down 
 - Second spring, curve facing up 
 - Third spring, curve facing down 
9. Take the upper male gland & place it rounded side up. 
10. Take three upper polyethylene packings & two leather packings & assemble with inverted side down,  on to the male gland in the following order: polyethylene, leather, polyethylene, leather, polyethylene.
11. Take upper female gland & place on top of assembled upper packings with the inverted side down. 
12. Take assembled upper glands & packings (7 pieces) & slide on over the top of the piston, making sure inverted sides are down.

13. Take the packing holder & replace the white O-ring & the black O-ring with new ones from the packing kit.
14. Slide the packing holder over the top of the upper packings so they fit inside.
15. Lubricate inside of the fluid pump body & the outside of the packings with a light weight oil.
16. Slide assembly into fluid pump body.

TO KEEP PACKINGS SECURED IN CORRECT POSITION, HOLD THE PUMP BODY UPSIDE DOWN & PUSH THE COMPLETED ASSEMBLY UPWARDS INTO THE PUMP BODY. ONCE PLACED INSIDE, TILT PUMP BODY BACK UP TO KEEP ALL PIECES IN.

17. Tighten packing nut onto the top of the fluid pump body & tighten until you feel slight resistance against the Belleville Springs. Using the Packing Adjustment Tool, tighten another 3/4 of a turn.
18. Reinstall Fluid Pump as instructed on page 14.

FIG. 14 PARTS LIST ON FOLLOWING PAGE

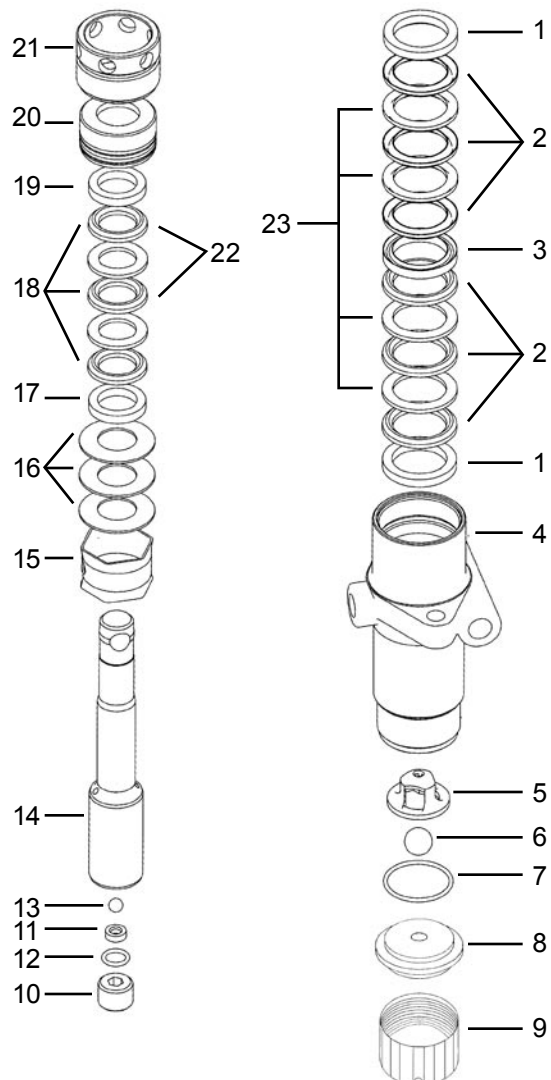

PACKING REPLACEMENT PROCEDURES

FIG. 15

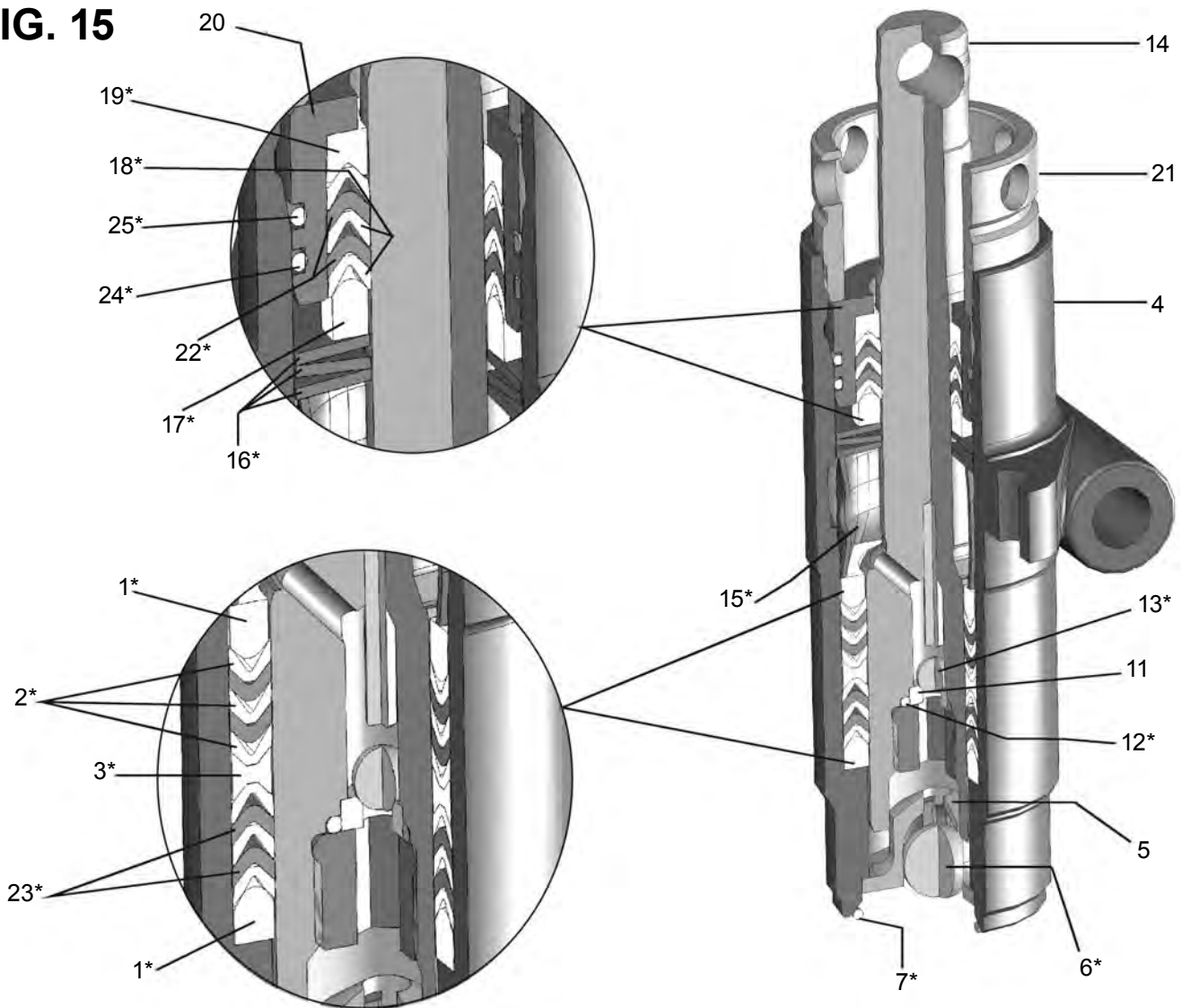

PARTS LIST FIGURE 14 & 15

Item No.	Part No.	Description
1	331-014*	Male Gland
2	331-016*	Packing Polyethylene
3	331-308*	Female Adaptor
4	331-011	Fluid Pump Body
5	331-029	Suction Ball Guide
6	331-030*	Suction Ball
7	106-011*	O-Ring
8	331-409	Suction Seat
9	331-034	Suction Nut
10	331-314	Outlet Seat Retainer
11	331-026	Outlet Seat
12	331-100*	O-Ring
13	331-027*	Outlet Ball

PARTS LIST FIGURE 14 & 15 CONT

Item No.	Part No.	Description
14	331-708	Piston
15	331-018*	Spacer
16	331-025*	Belleville Springs
17	331-022*	Male Gland
18	331-023*	Packing Polyethylene
19	331-021*	Female Gland
20	331-019	Packing Holder
21	331-037	Packing Nut
22	331-307*	Packing Leather
23	331-306*	Packing Leather
24	106-009*	White O-Ring
25	106-010*	Black O-Ring
*	331-210	Packing Kit

INSPECTION & REPLACEMENT OF CONTROL VALVE, BALL & SEAT

1. Use a wrench to unscrew control valve with Stat O-Seal.
2. Make sure that the control valve knob turns freely and that its stem is not worn unevenly, mushroomed or otherwise damaged.
3. Remove TC guide, verify that it is unbroken, clean and notch side is up.
4. Remove control ball. Inspect for any cuts, scratches, chips, rust or other damage.
5. Use a 7/16" allen wrench to unscrew the control seat from the valve body. Clean seat and inspect bevel edge for damage. Also ensure that the gasket on the underside of the seat is intact.
6. If no obvious damage to the control ball and seat, place ball into seat and fill with water. If water leaks out between ball and seat, they must be replaced.
7. Replace control valve, ball, seat and/or TC guide as necessary.
8. Clean and inspect valve body opening, where the control seat was installed.
9. Grease valve body opening with multipurpose grease.
10. Screw control seat into valve body and torque to 85 ft-lbs.
11. Place TC guide into control seat with notched side up.
12. Drop control ball into TC guide.
13. Screw control valve with ring seal into pump head. Torque to 15 ft-lbs.
14. If a new control valve, ball or seat is installed, complete the Pressure Calibration Procedure.

A REPAIR KIT WITH THE CONTROL BALL AND SEAT IS AVAILABLE AS KIT-3-3100.

PRESSURE CONTROL CALIBRATION

DO NOT USE THIS PROCEDURE WITHOUT A TEST GAUGE!

1. Install a gun, flexible airless hose and Airlessco part # 111-045 glycerin filled test gauge onto unit.
2. Prime unit.
3. Turn the control valve knob fully clockwise (maximum pressure setting).
4. Read the gauge, it should be approximately 1500 PSI.
5. If maximum pressure is incorrect, remove the orange plastic cap from the control valve knob. Insert a 3/16" allen wrench into the control valve knob set screw, turn clockwise to increase pressure and counter-clockwise to decrease pressure. Replace orange plastic cap.
6. ***NEVER*** set the maximum pressure above 1500 PSI.

NOTE: NEW CONTROL VALVE REQUIRES A BREAK-IN PERIOD. RUN THE UNIT UNDER PRESSURE FOR APPROXIMATELY 15 MINUTES OR UNTIL THE MAXIMUM PRESSURE IS STEADY.

BYPASS VALVE ASSEMBLY (305-264)

FIG. 16

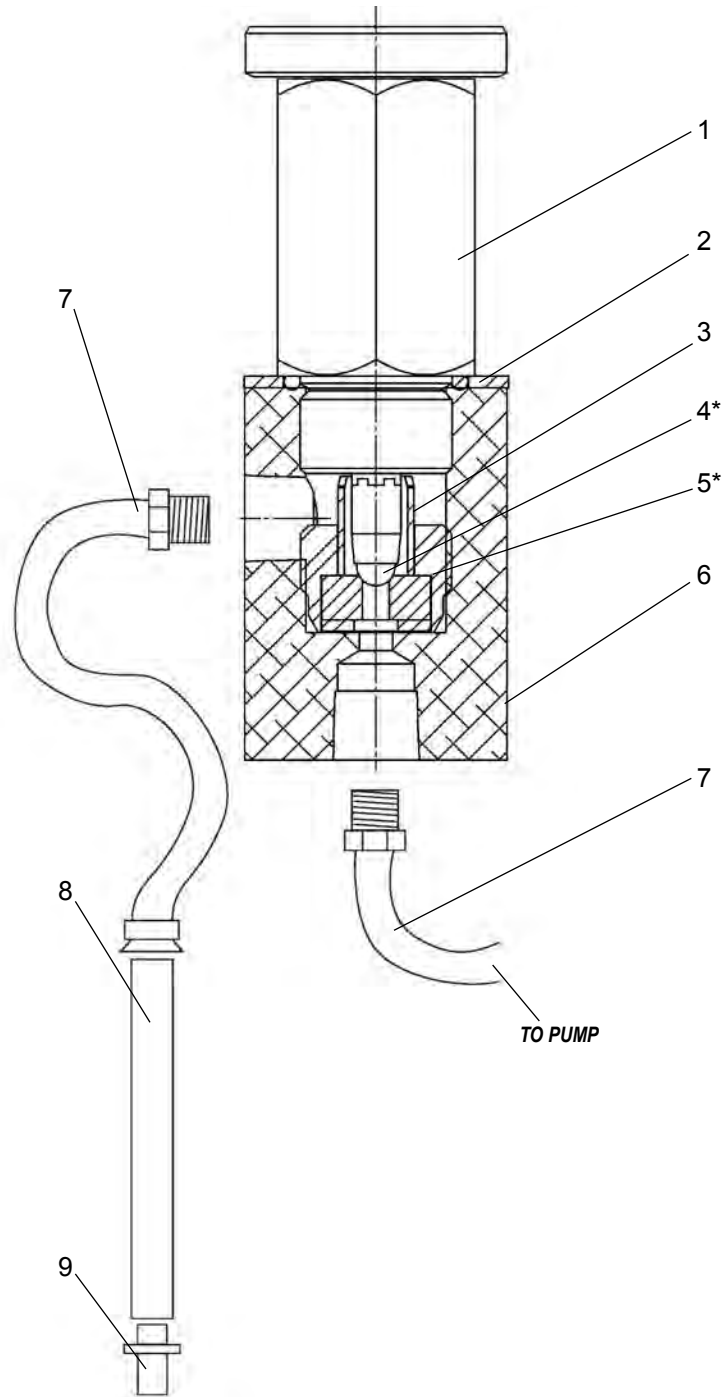

PARTS LIST FIGURE 16		
Item No.	Part No.	Description
1	115-058	Control Valve
2	115-028	Stat-O-Seal
3	115-031	Guide T.C.
4	*115-017	Ball
5	*115-016	Control Valve Seat Assy

PARTS LIST FIGURE 16 CONT		
Item No.	Part No.	Description
6	305-194	PR Regulator Housing
7	100-040	Whip Hose (2)
8	188-377	Return Tube
9	305-293	Deflector
*	KIT-3-3100	Repair Kit

GEARBOX (305-378)

FIG. 17

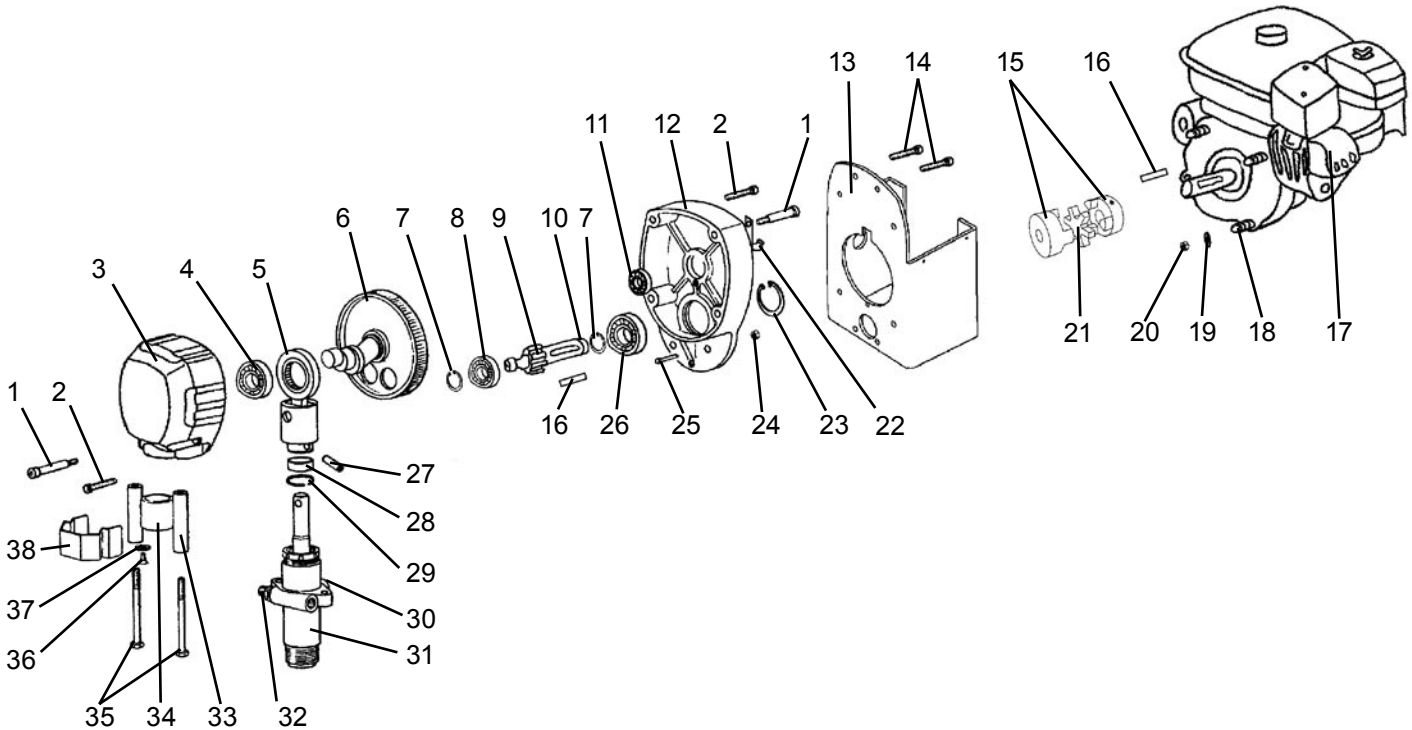

PARTS LIST FIGURE 17		
Item No.	Part No.	Description
1	100-380	Shoulder Screw (2)
2	100-381	Screw (2)
3	331-537	Cover
4	331-046	Ball Bearing
5	331-038	Crosshead Assy
6	331-407	Crank Assy
7	113-093	Retaining Ring
8	112-068	Ball Bearing
9	305-199	Pinion Shaft
10	106-019	O-Ring
11	305-047	Ball Bearing
12	305-287	End Bell
13	305-342	Mounting Box Bracket
14	100-374	Screw (4)
15	305-281	Coupling Hub (2)
16	112-029	Key (2)
17	175-032	Motor Duro 4HP
18	100-309	Set Screw (4)
19	113-023	Washer (4)
20	100-315	Nut (4)

PARTS LIST FIGURE 17 CONT		
Item No.	Part No.	Description
21	305-284	Spider Gear
22	106-031	J-Clip
23	100-398	Retaining Ring
24	136-217	Nut (2)
25	188-041	Screw(2)
26	117-008	Bearing
27	119-028	Pin
28	331-117	Sleeve
29	331-062	Retaining Spring
30	100-028	1/4" Plug
31	331-209	Fluid Pump
32	115-019	Hose Connector
33	331-074	Spacer (2)
34	331-061	Sleeve Bearing
35	100-318	Screw (2)
36	331-197	Screw (2)
37	331-103	Washer (2)
38	331-111	Cover Guard
*	331-132	Grease (1 lb)

FRAME ASSEMBLY (305-213)

FIG. 18

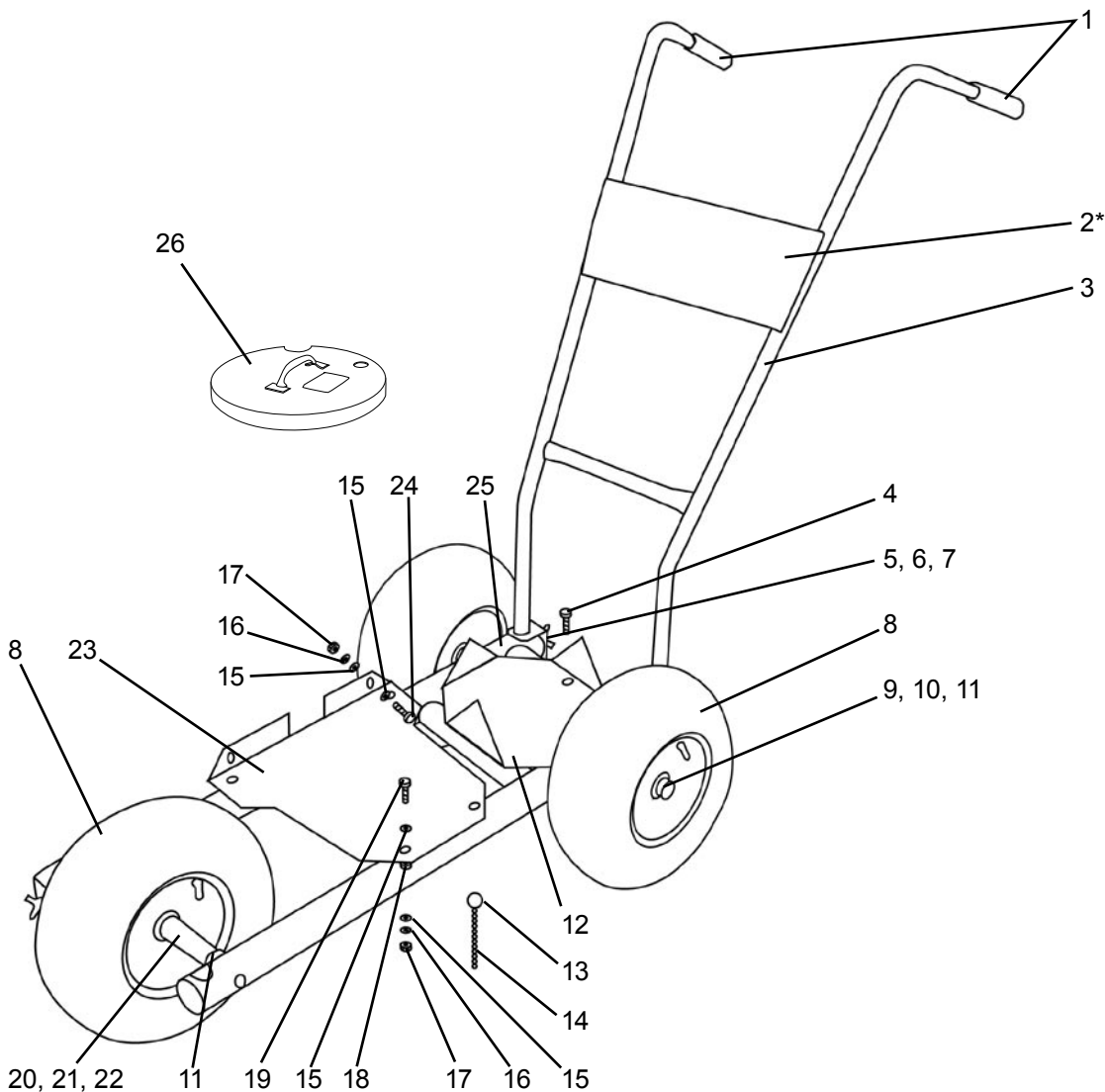

*** NOT INCLUDED IN FRAME ASSEMBLY**

PARTS LIST FIGURE 18

Item No.	Part No.	Description
1	305-058	Rubber Grip (2)
2*	101-349	Label - SS3000
3	139-053	Handle
4	119-026	Screw (3)
5	100-320	Wing Screw (2)
6	305-051M	Clamp (2)
7	305-108	Plate (2)
8	301-166	Wheel (3)
9	188-367	Axle
10	113-030	Spacer (2)
11	143-029	Set Collar (4)
12	305-262	Bucket Base
13	136-133	Key Ring
14	136-131	Chain Sash

PARTS LIST FIGURE 18 CONT

Item No.	Part No.	Description
15	100-344	Washer (12)
16	113-023	Lock Washer (6)
17	113-022	Nut (6)
18	301-536	Shock Mount (4)
19	301-547	Screw (4)
20	113-032	Axle
21	112-059	Spacer
22	143-028	Washer (2)
23	305-343	Mounting Plate
24	169-050	Screw (2)
25	305-353	Striper Frame
26*	305-533	Bucket Lid
-	116-103	Spring Clip (4) (not shown)

SPRAY GUN ASSEMBLY (305-280)

FIG. 19

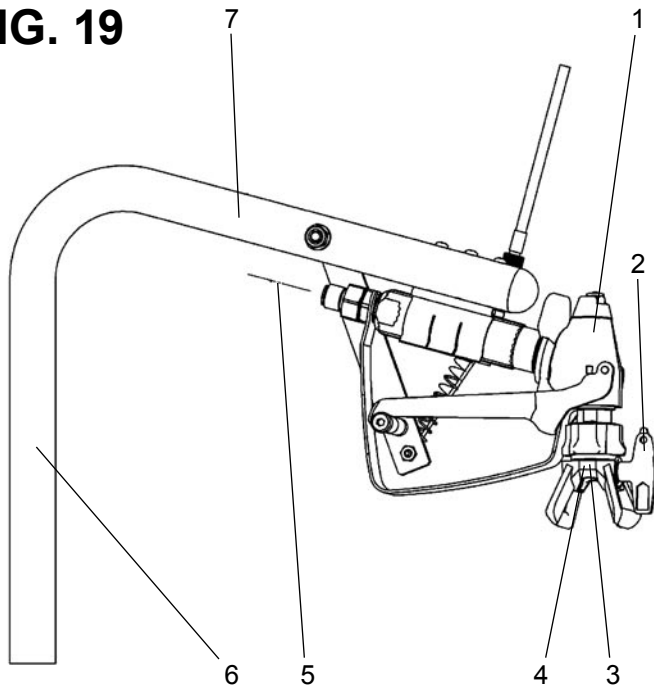

PARTS LIST FIGURE 19

Item No.	Part No.	Description
1	120-554	008 Gun
2	562-317ST	Striping Tip
3	561-025	Rev-Tip Male Seal
4	561-026	Rev- Tip Seal
5	100-011	Airless 1/4" x 50' Hose
6	116-105	Spring Clip
7	305-370	Gun Mount Assy
8	560-517	Painting Tip (not installed)

GUN MOUNT ASSEMBLY (305-370)

FIG. 20

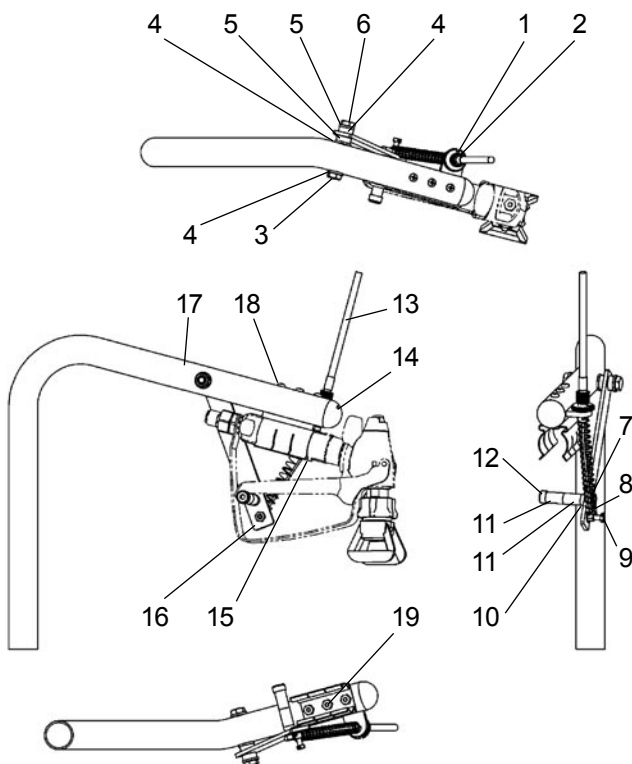

PARTS LIST FIGURE 20

Item No.	Part No.	Description
1	305-089	Cable Sleeve
2	305-141	Cable Adjustor
3	136-217	Nut
4	331-103	Washer (3)
5	305-273	Spacer (2)
6	119-049R	Screw
7	116-100	Compression Spring
8	305-079	Wire Swivel Assy
9	140-045	Nut
10	305-161	Spacer
11	305-159	Sleeve Bearing (2)
12	100-342	Screw
13	100-651	Cable Assy
14	143-027	Ball Guide
15	111-036	Spring Clip
16	305-274	Trigger Lever
17	305-272	Gun Mount Tube
18	119-050R	Screw (3)
19	119-052	Nut (3)
20	305-142	Lever Assy

SUCTION ASSEMBLY (331-290)

FIG. 21

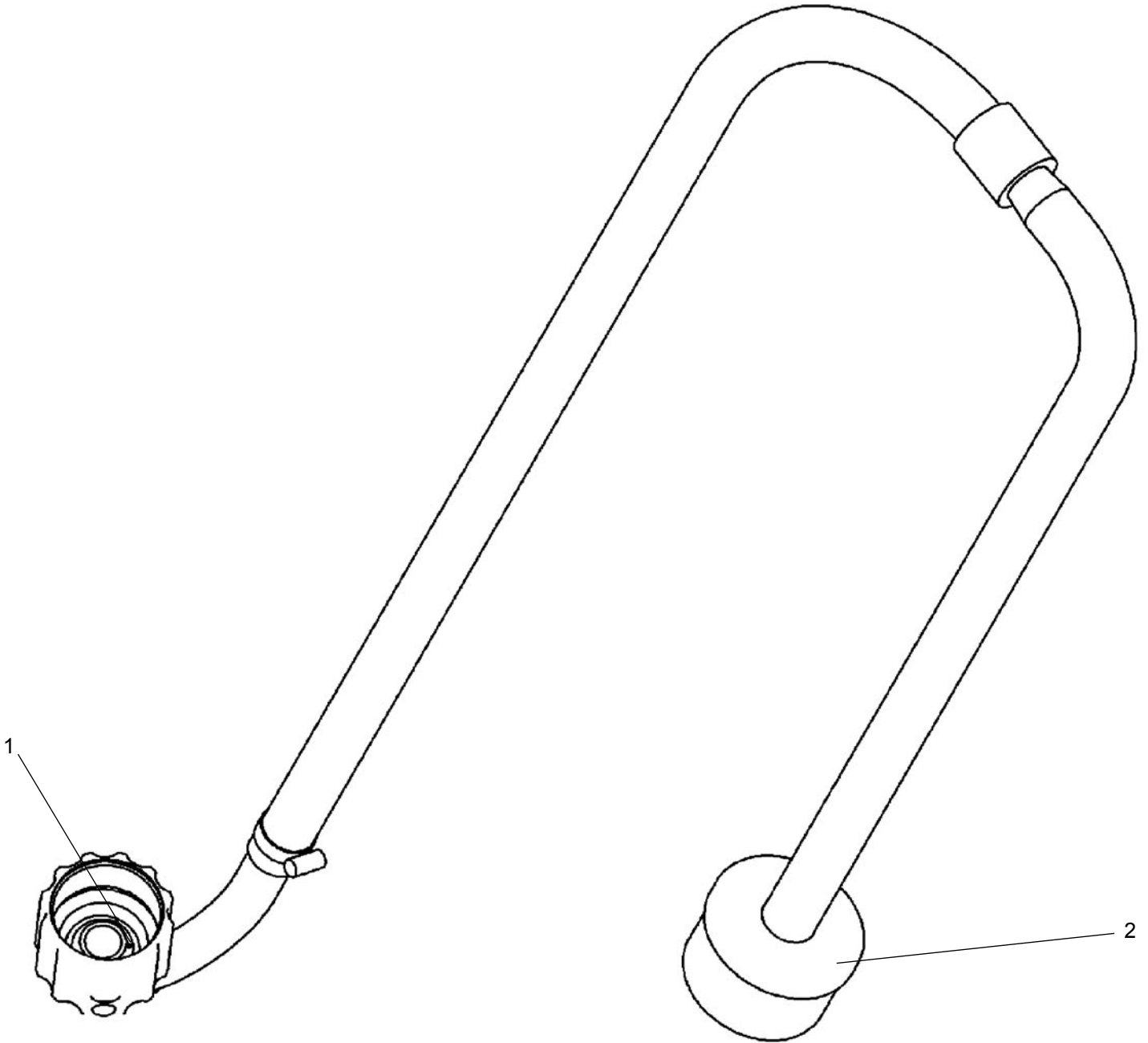

PARTS LIST FIGURE 21

Item No.	Part No.	Description
1	106-020	PTFE O-Ring
2	331-217	Suction Filter

STRIPING ACCESSORIES

POINTER

For easy line-up and striping of long lines.
PART # 136-069

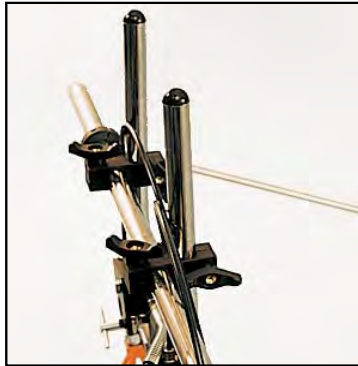

12GAL CONTAINER

High capacity plastic paint bucket
PART # 189-006



STENCIL KIT

For use on any single gun striper for stencilling or spraying paint. Includes a 2nd gun, 50' of 1/4" airless hose, 18" extension pole & shut-off ball valve.
PART # 305-399

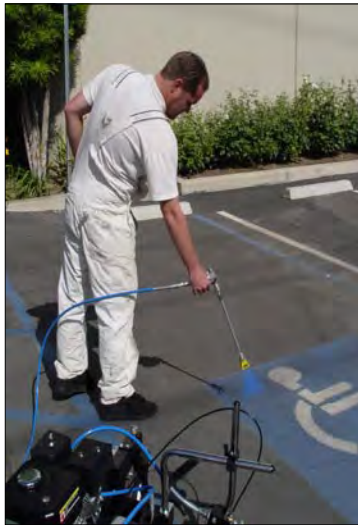

BEAD DISPENSERS

Gravity type glass bead dispenser kits.
1 GUN 4" PN 305-174
1 GUN 4-6" PN 305-186

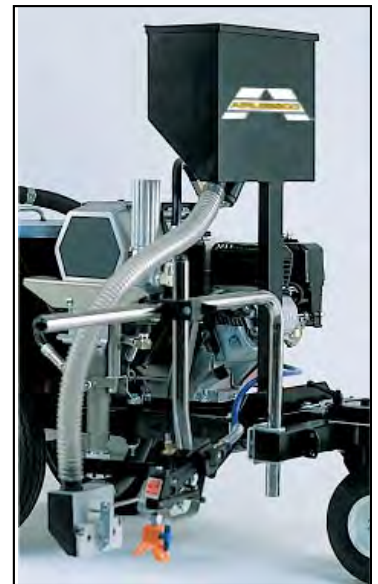

FLOATING SPRAY GUN KIT

Upgrades any Brite Striper 3000 striper to a floating gun mount for consistent width lines on bumpy, uneven surfaces like sports fields. Wheels provide added wind protection for spray pattern.
PART # 305-355. (PATENT PENDING)



Quick Flush™

- The only clean water flushing system
- Cuts sprayer clean-up time in half!
- Connects to standard garden hose to backflush sprayer through gun
- Includes "F" and "G" adapters to work with all brands of gun

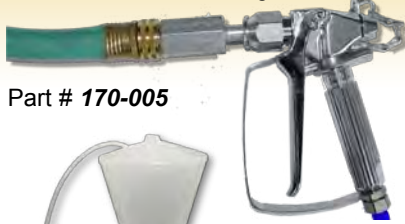

Part # 170-005



PAINT HOPPER

For use on small jobs where paint is kept in smaller than 5 gallon containers. Threads onto pick-up tube of carry or LoBoy framed Airlessco sprayers.

331-775 6 Liter Paint Hopper



PUMP CONDITIONER

Should be used on piston pumps between uses to prevent paint from drying on the piston & causing packing wear.

010-001 Display of 48 - 1 oz. bottles
 010-009 1 quart bottle
 010-019 1 Gallon bottle

Case quantity: 12 on quarts, 4 on gallons



PAINT STRAINERS

Pre-filter your paint using strainer bags. One dozen per pack.

100-064 Used to cover suction filter
 100-065 5 Gallon strainer



HOSE COVER

4 mil poly protects your airless hose from paint and abrasion damage. Comes in 1000' roll with perforations every 50'.

100-219 Hose Cover Roll
 100-426 Case of 6 Rolls



HIGH PRESSURE AIRLESS HOSE

Strong yet flexible, for airless sprayers up to 3300 PSI

Part No:	Hose Description
100-012	3/16" Whip Hose, 4 Ft.
100-040	1/4" Whip Hose, 3 Ft.
100-204	1/4" Whip Hose, 5 Ft.
100-199	3/8" Whip Hose, 6 Ft.
100-011	1/4" Hose, 50 Ft.
100-023	3/8" Hose, 50 Ft.
100-037	1/2" Hose, 50 Ft.
100-010	1/4" Hose Connector
100-009	3/8" Hose Connector



STAY CLEAN™

Spray protectant for machine to prevent paint from sticking to it. Keeps your sprayer looking new for years!

114-030 20 oz. can
 Case quantity: 12 cans



THROAT SEAL OIL

Used in the wet cup of a piston pump to prevent paint from drying on the piston & causing damage to the upper packing. Use with all piston pumps.

188-187 6 oz. Bottle
 188-392 1 qt. Bottle



XTEND-A-POLE SYSTEM

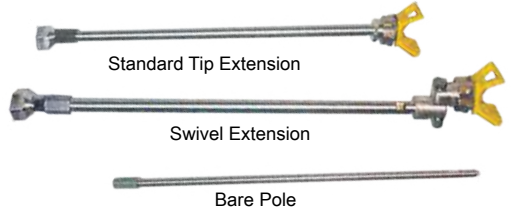

STANDARD TIP EXTENSION, "G" Thread

032-170 6" Long
 032-171 12" Long
 032-172 18" Long
 032-173 24" Long

SWIVEL EXTENSION, "G" Thread

032-184 36" Long

BARE POLE

Add Tip Extension or Swivel Extension to create desired length

032-053 24" Long
 032-054 36" Long

SWIVEL "G" THREAD

032-035 7/8" x 14 Swivel



ADAPTERS

	90° Pole to Gun Adapter 032-042
	Gun Nut "F" Thread 11/16-16 032-010
	Gun Nut "G" Thread 7/8-14 032-011
	"F to G" Gun adapter to attach Graco® tips to Airlessco guns. 032-012