

Repair - Parts List



LineLazer™ IV 3900, 5900, and FieldLazer R300 Airless Line Stripers

Chinese Patent ZL03801904.3; Australian Patent No. 2005319204, 2006208117; Russian Patent No. 2398927;
U.S. Patent 6,913,417; 7,654,771; Europe Patent No. 1841310, Ukraine Registration No. 90886

311020U
EN

- *For application of line striping materials* -

3300 psi (228 bar, 22.8 MPa) Maximum Working Pressure



Important Safety Instructions

Read all warnings and instructions in this manual. Save these instructions.



311017
312540



310643



311254



309055



311049

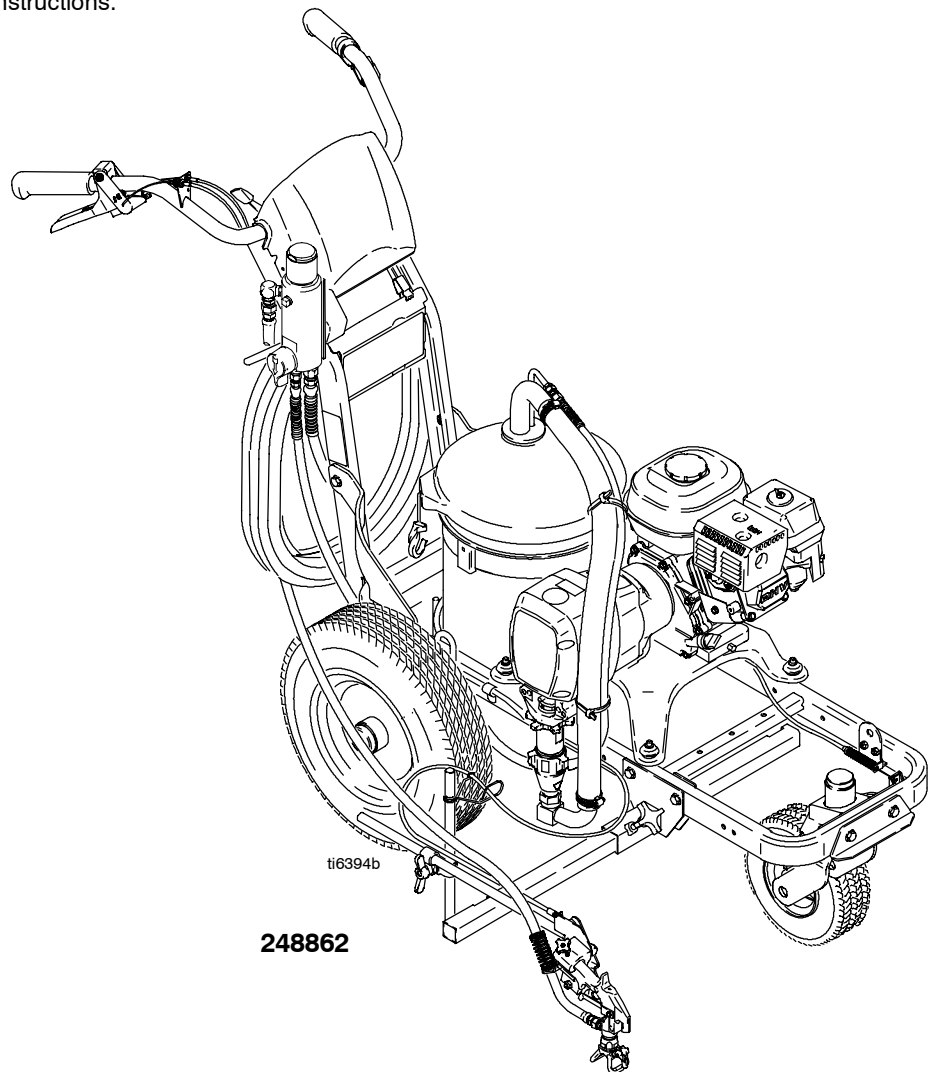

248862







PROVEN QUALITY. LEADING TECHNOLOGY.







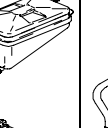
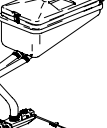
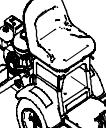







Table of Contents

Models	3	Distance Sensor Adjustment	19
Warnings	4	Control Board Diagnostics	20
Spray Tip Selection Table	6	Displacement Pump	21
Maintenance	7	Parts	
Troubleshooting	8	LineLazer IV 3900/5900	22
Repair		Drive and Pinion Housing Assemblies	23
Bearing Housing & Connecting Rod	11	Pressure Control Wiring Diagram	34
Drive Housing	12	Technical Data	35
Pinion Assembly/Clutch Armature/Clamp	13	Dimensions	35
Engine	16	Graco Phone Number	35
Pressure Control	17	Graco Warranty	36
Trigger Sensor Adjustment	19		

Models





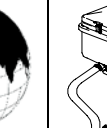
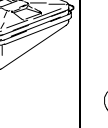

 3900						
248862	✓		✓			
248863		✓	✓			
249008	✓			✓		
249009		✓		✓		
248864	✓		✓		✓	
248865		✓	✓			✓

 R300								
24M605	✓		✓				✓	✓
24M607	✓		✓					

 5900						
248866	✓		✓			
248867		✓	✓			
249010	✓			✓		
249011		✓		✓		
248868	✓		✓		✓	
248869		✓	✓			✓

Warnings

The following Warnings are for safe setup, use, grounding, maintenance and repair of this equipment. The exclamation point symbol alerts you to a general warning and the hazard symbols refer to procedure-specific risks. Refer back to these Warnings.

 WARNING	
	<p>FIRE AND EXPLOSION HAZARD</p> <p>Flammable fumes, such as solvent and paint fumes, in work area can ignite or explode. To help prevent fire and explosion:</p> <ul style="list-style-type: none">• Use equipment only in well ventilated area.• Do not fill fuel tank while engine is running or hot; shut off engine and let it cool. Fuel is flammable and can ignite or explode if spilled on hot surface.• Eliminate all ignition sources; such as pilot lights, cigarettes, portable electric lamps, and plastic drop cloths (potential static arc).• Keep work area free of debris, including solvent, rags and gasoline.• Do not plug or unplug power cords, or turn power or light switches on or off when flammable fumes are present.• Ground equipment and conductive objects in work area. See Grounding instructions.• Use only grounded hoses.• Hold gun firmly to side of grounded pail when triggering into pail.• If there is static sparking or you feel a shock, stop operation immediately. Do not use equipment until you identify and correct the problem.• Keep a fire extinguisher in work area.
	<p>CARBON MONOXIDE HAZARD</p> <p>Exhaust contains poisonous carbon monoxide, which is colorless and odorless. Breathing carbon monoxide can cause death. Do not operate in an enclosed area.</p>
	<p>SKIN INJECTION HAZARD</p> <p>High-pressure fluid from gun, hose leaks, or ruptured components will pierce skin. This may look like just a cut, but it is a serious injury that can result in amputation. Get immediate surgical treatment.</p> <ul style="list-style-type: none">• Do not point gun at anyone or at any part of the body.• Do not put your hand over the spray tip.• Do not stop or deflect leaks with your hand, body, glove, or rag.• Do not spray without tip guard and trigger guard installed.• Engage trigger lock when not spraying.• Follow Pressure Relief Procedure in this manual, when you stop spraying and before cleaning, checking, or servicing equipment.
	<p>PRESSURIZED EQUIPMENT HAZARD</p> <p>Fluid from the gun/dispense valve, leaks, or ruptured components can splash in the eyes or on skin and cause serious injury.</p> <ul style="list-style-type: none">• Follow Pressure Relief Procedure in this manual, when you stop spraying and before cleaning, checking, or servicing equipment.• Tighten all fluid connections before operating the equipment.• Check hoses, tubes, and couplings daily. Replace worn or damaged parts immediately.
	<p>PRESSURIZED ALUMINUM PARTS HAZARD</p> <p>Do not use 1,1,1-trichloroethane, methylene chloride, other halogenated hydrocarbon solvents or fluids containing such solvents in pressurized aluminum equipment. Such use can cause serious chemical reaction and equipment rupture, and result in death, serious injury, and property damage.</p>

WARNING



EQUIPMENT MISUSE HAZARD

Misuse can cause death or serious injury.

- Do not exceed the maximum working pressure or temperature rating of the lowest rated system component. See **Technical Data** in all equipment manuals.
- Use fluids and solvents that are compatible with equipment wetted parts. See **Technical Data** in all equipment manuals. Read fluid and solvent manufacturer's warnings.
- Check equipment daily. Repair or replace worn or damaged parts immediately.
- Do not alter or modify equipment.
- Use equipment only for its intended purpose. Call your Graco distributor for information.
- Route hoses and cables away from traffic areas, sharp edges, moving parts, and hot surfaces.
- Do not kink or over bend hoses or use hoses to pull equipment
- Keep children and animals away from work area.
- Comply with all applicable safety regulations.



BURN HAZARD

Equipment surfaces and fluid that's heated can become very hot during operation. To avoid severe burns, do not touch hot fluid or equipment. Wait until equipment/fluid has cooled completely.



MOVING PARTS HAZARD

Moving parts can pinch or amputate fingers and other body parts.

- Keep clear of moving parts.
- Do not operate equipment with protective guards or covers removed.
- Pressurized equipment can start without warning. Before checking, moving, or servicing equipment, follow the **Pressure Relief Procedure** in this manual. Disconnect power or air supply.



PERSONAL PROTECTIVE EQUIPMENT

You must wear appropriate protective equipment when operating, servicing, or when in the operating area of the equipment to help protect you from serious injury, including eye injury, inhalation of toxic fumes, burns, and hearing loss. This equipment includes but is not limited to:

- Protective eyewear.
- Clothing and respirator as recommended by the fluid and solvent manufacturer.
- Gloves.
- Hearing protection.



RECOIL HAZARD

Brace yourself; gun may recoil when triggered and cause you to fall, which could cause serious injury.

Tip Selection

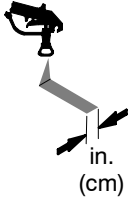
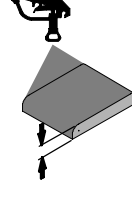
	 in. (cm)	 in. (cm)	 in. (cm)	 in. (cm)			
LL5213*	2 (5)				✓		
LL5215*	2 (5)					✓	
LL5217		4 (10)				✓	
LL5219		4 (10)					✓
LL5315*		4 (10)			✓		
LL5317		4 (10)			✓		
LL5319		4 (10)				✓	
LL5321		4 (10)				✓	
LL5323		4 (10)				✓	
LL5325		4 (10)					✓
LL5327		4 (10)					✓
LL5329		4 (10)					✓
LL5331		4 (10)					✓
LL5333		4 (10)					✓
LL5335		4 (10)					✓
LL5355		4 (10)					✓
LL5417			6 (15)		✓		
LL5419			6 (15)		✓		
LL5421			6 (15)		✓		
LL5423			6 (15)			✓	
LL5425			6 (15)			✓	
LL5427			6 (15)			✓	
LL5429			6 (15)			✓	
LL5431			6 (15)				✓
LL5435			6 (15)				✓
LL5621				12 (30)	✓		
LL5623				12 (30)	✓		
LL5625				12 (30)	✓		
LL5627				12 (30)	✓		
LL5629				12 (30)	✓		
LL5631				12 (30)		✓	
LL5635				12 (30)		✓	
LL5639				12 (30)			✓

* Use 100 mesh filter to reduce tip clogs

Maintenance



Pressure Relief Procedure

1. Lock gun trigger safety.
2. Turn engine ON/OFF switch to OFF.
3. Move pump switch to OFF and turn pressure control knob fully counterclockwise.
4. Unlock trigger safety. Hold metal part of gun firmly to side of grounded metal pail, and trigger gun to relieve pressure.
5. Lock gun trigger safety.
6. Open pressure drain valve. Leave valve open until ready to spray again.

If you suspect that the spray tip or hose is completely clogged, or that pressure has not been fully relieved after following the steps above, VERY SLOWLY loosen tip guard retaining nut or hose end coupling to relieve pressure gradually, then loosen completely. Now clear tip or hose.

CAUTION

- Minimum hose size allowable for proper sprayer operation is 3/8 in. x 50 ft
- For detailed engine maintenance and specifications, refer to separate Honda Engines Owner's Manual, supplied.

DAILY: Check engine oil level and fill as necessary.

DAILY: Check hose for wear and damage.

DAILY: Check gun safety for proper operation.

DAILY: Check pressure drain valve for proper operation.

DAILY: Check and fill the gas tank.

AFTER THE FIRST 20 HOURS OF OPERATION:

Drain engine oil and refill with clean oil. Reference Honda Engines Owner's Manual for correct oil viscosity.

WEEKLY: Remove air filter cover and clean element. Replace element, if necessary. If operating in an unusually dusty environment: check filter daily and replace, if necessary.

Replacement elements can be purchased from your local HONDA dealer.

WEEKLY: Check level of TSL in displacement pump packing nut. Fill nut, if necessary. Keep TSL in nut to help prevent fluid buildup on piston rod and premature wear of packings.

AFTER EACH 100 HOURS OF OPERATION:

Change engine oil. Reference Honda Engines Owner's Manual for correct oil viscosity.

SPARK PLUG: Use only BPR6ES (NGK) or W20EPR-U (NIPPONDENSO) plug. Gap plug to 0.028 to 0.031 in. (0.7 to 0.8 mm). Use spark plug wrench when installing and removing plug.

Caster Wheel

(See letter call-outs in **Parts** drawing on page 28)

1. Once each year, tighten nut (127) under dust cap (142) until spring washer bottoms out. Then back off the nut 1/2 to 3/4 turn.
2. Once each year, tighten nut (127) on screw (131) until it begins to compress spring washer. Then tighten the nut an additional 1/4 turn.
3. Once each month, grease the wheel bearing (F).
4. Check pin (55) for wear. If pin is worn out, there will be play in the caster wheel. Reverse or replace the pin as needed.
5. Check caster wheel alignment as necessary. To align: loosen screw (145), align wheel and tighten screw.

Troubleshooting



PROBLEM	CAUSE	SOLUTION
E=XX is displayed	Fault condition exists	Determine fault correction from table, page 20.
Engine won't start	Engine switch is OFF	Turn engine switch ON
	Engine is out of gas	Refill gas tank. Honda Engines Owner's Manual.
	Engine oil level is low	Try to start engine. Replenish oil, if necessary. Honda Engines Owner's Manual.
	Spark plug cable is disconnected or damaged	Connect spark plug cable or replace spark plug
	Cold engine	Use choke
	Fuel shutoff lever is OFF	Move lever to ON position
	Oil is seeping into combustion chamber	Remove spark plug. Pull starter 3 to 4 times. Clean or replace spark plug. Start engine. Keep sprayer upright to avoid oil seepage.
Engine operates, but displacement pump does not operate	Error code displayed?	Reference pressure control repair. Page 18.
	Pump switch is OFF	Turn pump switch ON.
	Pressure setting is too low	Turn pressure adjusting knob clockwise to increase pressure.
	Fluid filter (11) is dirty	Clean filter. Page 32.
	Tip or tip filter is clogged	Clean tip or tip filter. See spray gun manual.
	Displacement pump piston rod is stuck due to dried paint	Repair pump. See pump manual.
	Connecting rod is worn or damaged	Replace connecting rod. Page 11.
	Drive housing is worn or damaged	Replace drive housing. Page 12.
	Electrical power is not energizing clutch field	Check wiring connections. Page 16. Reference pressure control repair. Page 18. Reference wiring diagram. Page 34. With pump switch ON and pressure turned to MAXIMUM, use a test light to check for power between clutch test points on control board. Measure resistance across clutch coil. At 70° F, the resistance must be between 1.2 ±0.2Ω (LineLazer IV 3900); 1.7 ±0.2Ω (LineLazer IV 5900); if not, replace pinion housing. Have pressure control checked by authorized Graco dealer.
Clutch is worn, damaged, or incorrectly positioned	Replace clutch. Page 13.	
Pinion assembly is worn or damaged	Repair or replace pinion assembly. Page 13.	

Troubleshooting

PROBLEM	CAUSE	SOLUTION
Pump output is low	Strainer (34f) is clogged	Clean strainer.
	Piston ball is not seating	Service piston ball. See pump manual.
	Piston packings are worn or damaged	Replace packings. See pump manual.
	O-ring in pump is worn or damaged	Replace o-ring. See pump manual.
	Intake valve ball is not seating properly	Clean intake valve. See pump manual.
	Intake valve ball is packed with material	Clean intake valve. See pump manual.
	Engine speed is too low	Increase throttle setting. See operation manual.
	Clutch is worn or damaged	Replace clutch. Page 13.
	Pressure setting is too low	Increase pressure. See operation manual.
	Fluid filter (11), tip filter or tip is clogged or dirty	Clean filter. See operation or spray gun manual.
	Large pressure drop in hose with heavy materials	Use larger diameter hose and/or reduce overall length of hose. Use of more than 100 ft of 1/4 in. hose significantly reduces performance of sprayer. Use 3/8 in. hose for optimum performance (50 ft minimum).
Excessive paint leakage into throat packing nut	Throat packing nut is loose	Remove throat packing nut spacer. Tighten throat packing nut just enough to stop leakage.
	Throat packings are worn or damaged	Replace packings. See pump manual.
	Displacement rod is worn or damaged	Replace rod. See pump manual.
Fluid is spitting from gun	Air in pump or hose	Check and tighten all fluid connections. Reprime pump. See operation manual.
	Tip is partially clogged	Clear tip. See spray gun manual.
	Fluid supply is low or empty	Refill fluid supply. Prime pump. See operation manual. Check fluid supply often to prevent running pump dry.
Pump is difficult to prime	Air in pump or hose	Check and tighten all fluid connections. Reduce engine speed and cycle pump as slowly as possible during priming.
	Intake valve is leaking	Clean intake valve. Be sure ball seat is not nicked or worn and that ball seats well. Reassemble valve.
	Pump packings are worn	Replace pump packings. See pump manual.
	Paint is too thick	Thin the paint according to the supplier's recommendations
	Engine speed is too high	Decrease throttle setting before priming pump. See operation manual.
Clutch squeaks each time clutch engages	Clutch surfaces are not matched to each other when new and may cause noise	Clutch surfaces need to wear into each other. Noise will dissipate after a day of run time.
High engine speed at no load	Misadjusted throttle setting	Reset throttle to 3600 engine rpm at no load
	Worn engine governor	Replace or service engine governor

Troubleshooting

PROBLEM	CAUSE	SOLUTION
Gallon counter not working	Broken or disconnected wire	Check wires and connections. Replace broken wires.
	Bad sensor	Replace sensor
	Missing magnet	Reposition or replace magnet.
Sprayer operates, but display does not	Bad connection between control board and display	Remove display and reconnect
	Display damaged	Replace display
Distance counter not operating properly	Trigger sensor not set correctly	See "Spray icon does not show on display when fluid is sprayed"
	Bad wiring connections	Check connector, and reconnect
	Distance sensor not spaced correctly from gear	Adjust space between sensor and gear to .050 +/- .020 in. See page 19.
	Distance sensor and gear not aligned	Remove tire, and press in or pull out gear to align sensor and gear.
	Gear teeth missing or damaged.	Replace distance gear/wheel
	Wire cracked or broken	Replace sensor
Mils not calculating	Distance sensor	See "Distance counter not operating properly"
	Trigger sensor	See "Spray icon does not show on display when fluid is sprayed"
	Gallon counter	See "Gallon counter not working"
	Bad or damaged control board	Replace control board
Fluid spray starts after spray icon is shown on display	Interrupter (164) is improperly positioned	Turn screw (126) counterclockwise until spray icon synchronizes with fluid spray
Fluid spray starts before spray icon is shown on display	Interrupter (164) is improperly positioned	Turn screw (126) clockwise until spray icon is synchronized with fluid spray
Spray icon does not show on display when fluid is sprayed	Loose connector	Check connector and reconnect
	Interrupter (164) is improperly positioned	Turn screw (126) counterclockwise until spray icon synchronizes with fluid spray
	Reed switch assembly (166) is damaged	Replace reed switch assembly (166)
	Magnet on assembly (166) is missing	Replace reed switch assembly (166)
	Cut or sliced wire	Replace distance sensor harness (66)
	Control board is damaged	Replace control board
	Display is damaged	Replace display
Spray icon is always shown on display	Interrupter (164) is improperly positioned	Turn screw (126) clockwise until spray icon is synchronized with fluid spray
	Reed switch assembly (166) is damaged	Replace reed switch assembly (166)

Bearing Housing and Connecting Rod

Removal



1. Relieve pressure, page 7.
2. Fig. 2. Remove screws (187) and front cover (83).
3. Unscrew suction tube (34) from pump, hold wrench on pump intake valve (A) to keep pump from loosening.
4. Disconnect pump outlet hose (100) from displacement pump outlet nipple (60).
5. Fig. 1. Use screwdriver to push up retaining spring (236) at top of pump. Push out pin (235).

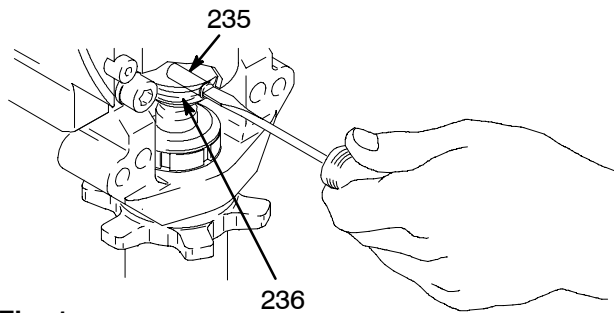

Fig. 1

7675B

6. Fig. 2. Loosen retaining nut (84). Unscrew and remove displacement pump (21).
7. Remove four screws (183) and lockwashers (173) from bearing housing (22).
8. Pull connecting rod (26) and lightly tap lower rear of bearing housing (22) with plastic mallet to loosen from drive housing (24). Pull bearing housing and connecting rod assembly (26) off drive housing.
9. Inspect crank (B) for excessive wear and replace parts as needed.

Installation

1. Evenly lubricate inside of bronze bearing (C) in bearing housing (22) with high-quality motor oil. Liberally pack top roller bearing (E), lower bearing (D) inside connecting rod assembly (26) with bearing grease.
2. Assemble connecting rod (26) and bearing housing (22).

3. Clean mating surfaces of bearing and drive housings.
4. Align connecting rod with crank (B) and carefully align locating pins (F) in drive housing (24) with holes in bearing housing (22). Push bearing housing onto drive housing or tap into place with plastic mallet.

CAUTION

DO NOT use bearing housing screws (183) to align or seat bearing housing with drive housing. Align these parts with locating pins (F), to avoid premature bearing wear.

5. Install screws (183) and lockwashers (173) on bearing housing. Torque evenly to note 3 value in Fig. 2.
6. Install pump. Refer to **Displacement Pump, Installation**, page 21.

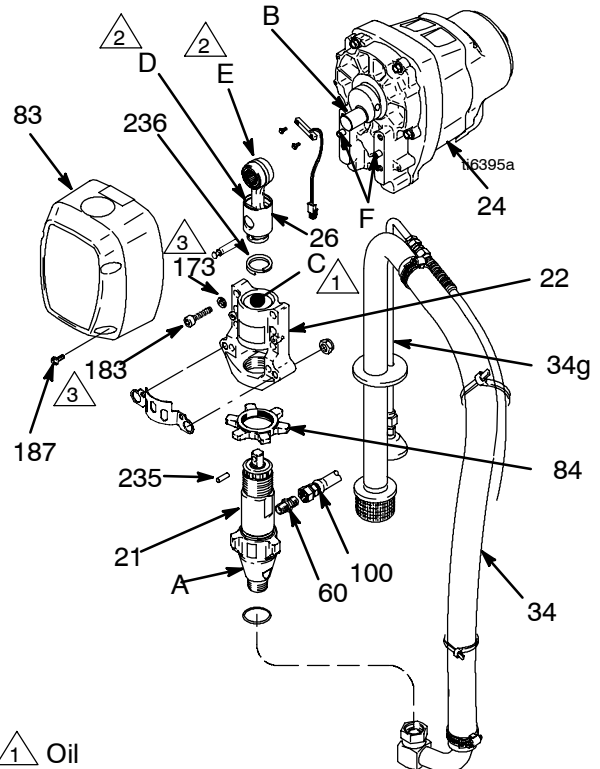

- 1 Oil
- 2 Pack with bearing grease 114819
- 3 LineLazer IV 3900: Torque to 200 in-lb (22.6 N·m)
LineLazer IV 5900: Torque to 25 ft-lb (34 N·m)

Fig. 2 **Model 248862 shown**

Drive Housing

Removal



1. Relieve pressure, page 7.
2. Fig. 3. Remove bearing housing. Do **Bearing Housing and Connecting Rod** procedure on page 11.
3. Remove two screws (158) and reed switch (182).
4. Remove six screws (189) from pinion housing (25).
5. Lightly tap around drive housing (24) to loosen drive housing. Pull drive housing straight off pinion housing. Be prepared to support gear cluster (23), which may also come out.

Installation

1. Liberally apply bearing grease (supplied with replacement gear cluster) to gear cluster (23) and to areas called out by note 2.
2. Place bronze colored washer (24g) on shaft protruding from large shaft of drive housing (24). Place silver colored washer (24h) on pinion housing. Clean mating surfaces of pinion and drive housings. Align gears and push new drive housing straight onto pinion housing and locating pins (A).
3. Install six screws (189). Torque evenly to note 1 value in Fig. 3.
4. Install reed switch (182) with two screws (158).
5. Install bearing housing. Do steps 1. through 6. of **Bearing Housing and Connecting Rod** procedure on page 11.

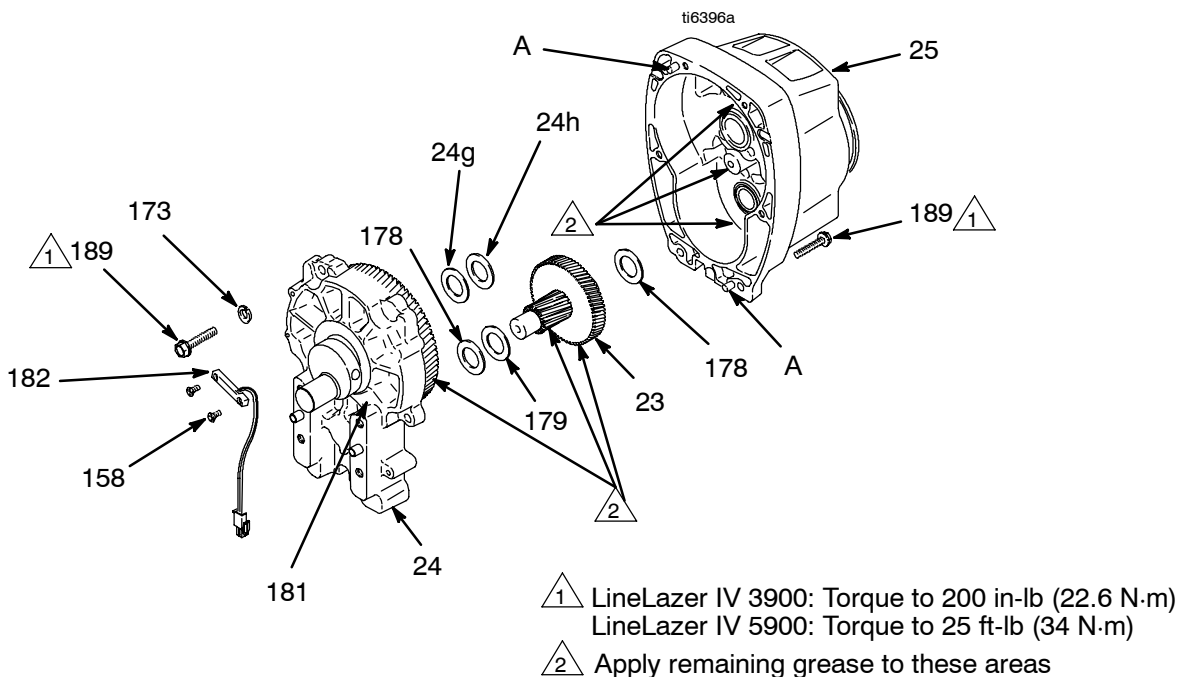

Fig. 3

Pinion Assembly/Clutch Armature/Clamp

Pinion Assembly/Clutch Armature Removal

Pinion Assembly

If pinion assembly (25) is not removed from clutch housing (85), do 1. through 3. Otherwise, start at 4.



1. Remove drive housing, page 12.
2. Fig. 12. Remove clip (251) and junction box (226).
3. Fig. 11. Disconnect pump stroke sensor and clutch cables.
4. Fig. 4. Remove four screws (189) and lockwashers (188) and pinion assembly (25).

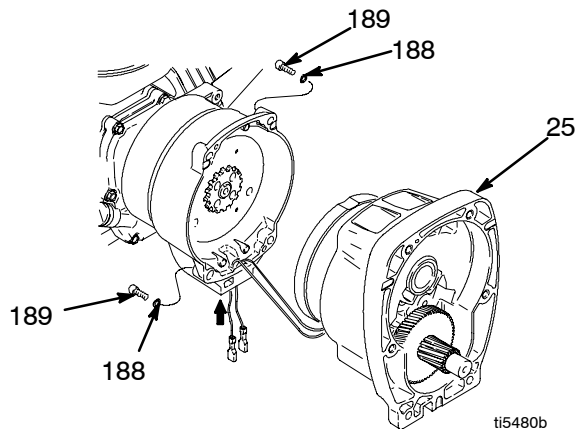

Fig. 4

5. Fig. 5. Place pinion assembly (25) on bench with rotor side up.
6. Remove four screws (170) and lockwashers (172). Install two screws in threaded holes (E) in rotor. Alternately tighten screws until rotor comes off.

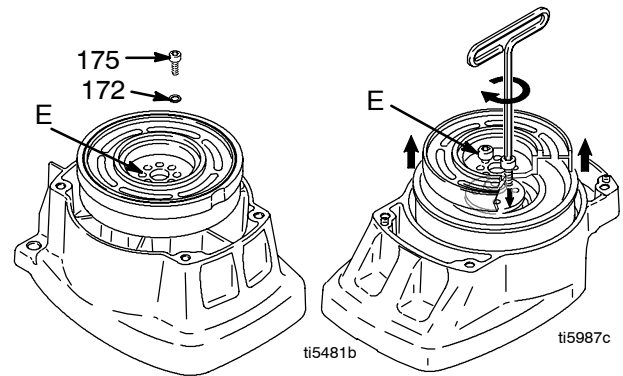

Fig. 5

7. Fig. 6. Remove retaining ring (25e).
8. Tap pinion shaft (25d) out with plastic mallet.

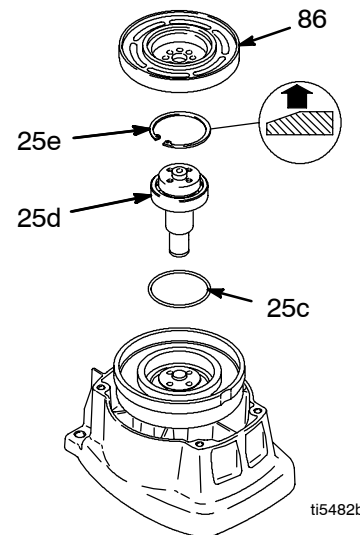

Fig. 6

Clutch Armature

9. Fig.7. Use an impact wrench or wedge something between armature (87) and clutch housing to hold engine shaft during removal.
10. Remove four screws (175) and lockwashers (172).
11. Remove armature (87).

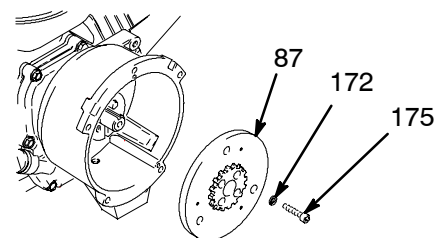

Fig. 7

Installation

Clutch Armature

1. Fig. 8. Lay two stacks of two dimes on smooth bench surface.
2. Lay armature (87) on two stacks of dimes.
3. Press center of clutch down on bench surface.

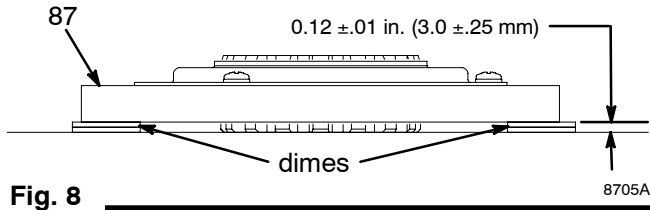

Fig. 8

4. Install armature (87) on engine drive shaft.
5. Install four screws (175) and lockwashers (172) with torque of 125 in-lb.

Clamp

Removal

1. Do Engine Removal.

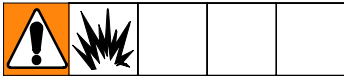

2. Drain gasoline from tank according to Honda manual.
3. Tip engine on side so gas tank is down and air cleaner is up.
4. Fig. 9. Loosen two screws (175) on clamp (82),
5. Push screwdriver into slot in clamp (82) and remove clamp.

Installation

1. Fig. 9. Install engine shaft key (88).
2. Tap clamp (82) on engine shaft (A) with plastic mallet. Maintain dimension shown note 2. Chamfer must face engine.
3. Check dimension: Place rigid, straight steel bar (B) across face of clutch housing (5). Use accurate measuring device to measure distance between bar and face of clamp. Adjust clamp as necessary. Torque two screws (175) to 125 ± 10 in-lb (14 ± 1.1 N.m).

Pinion Assembly

6. Fig. 6. Check o-ring (25c) and replace if missing or damaged.
7. Tap pinion shaft (25d) in with plastic mallet.
8. Install retaining ring (25e) with beveled side facing up.
9. Fig. 5. Place pinion assembly on bench with rotor side up.
10. Apply thread sealant to screws. Install four screws (170) and lockwashers (172). Alternately torque screws to 125 in-lb until rotor is secure. Use threaded holes to hold rotor.
11. Fig. 4. Install pinion assembly (25) with five screws (189) and lockwashers (188).
12. Fig. 11. Connect pump stroke sensor and clutch cables.
13. Fig. 12. Install junction box (226) with clip (251).

- 1 Face of clutch housing
- 2 2.55 ± 0.10 in. (39.37 ± 0.25 mm); LineLazer IV 3900
2.61 ± 0.10 in. (66.29 ± 0.25 mm); LineLazer IV 5900
- 3 Torque to 125 ± 10 in-lb (14 ± 1.1 N.m)
- 4 Chamfer this side

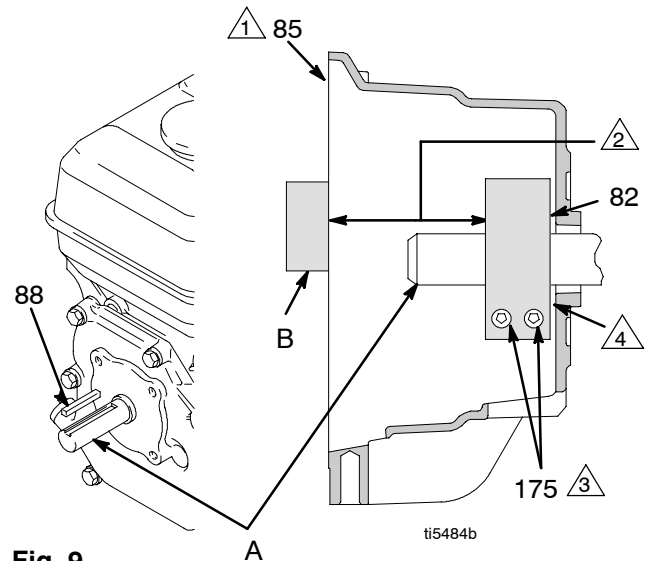

Fig. 9

Clutch Housing

Removal

1. Fig. 10. Remove four cap screws (186) and lock washers (188) which hold clutch housing (85) to engine.
2. Remove screw (177) from under mounting plate (96).
3. Pull off clutch housing (85).

Installation

1. Fig. 10. Push on clutch housing (5).
2. Install four cap screws (186) and lock washers (188) and secure clutch housing (85) to engine. Torque to 200 in-lb (22.6 N•m).
3. Install capscrew (177) from beneath mounting plate (96). Torque to 26 ft-lb (35.2 N•m).

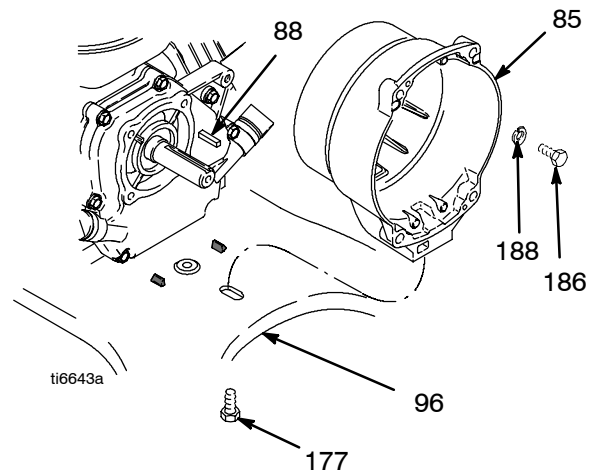

Fig. 10

Engine

Removal

1. Remove **Pinion Assembly/Clutch Armature/Clamp** and **Clutch Housing**. See pages 11 - 15.
2. Fig. 12. Remove clip (251) and junction box (226).
3. Fig. 11. Disconnect all necessary wiring.
4. Fig. 12. Remove screw (177). Remove two screws (117), locknuts (118), and ground conductor (230, 260) from base of engine (185).
5. Lift engine carefully and place on work bench.

NOTE: All service to the engine must be performed by an authorized HONDA dealer.

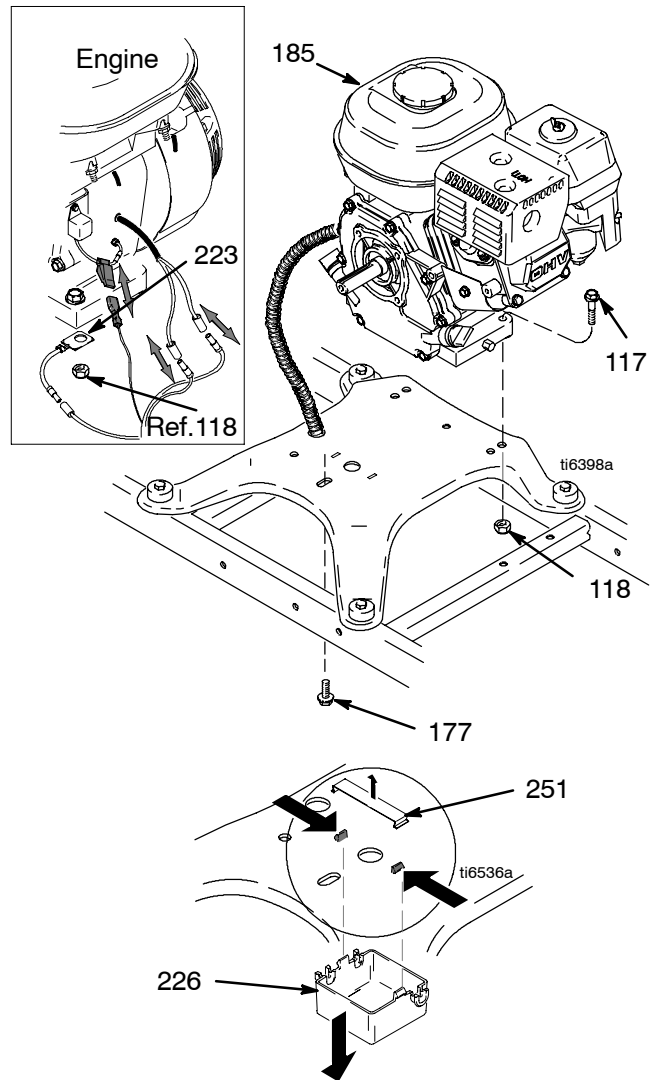

Fig. 12

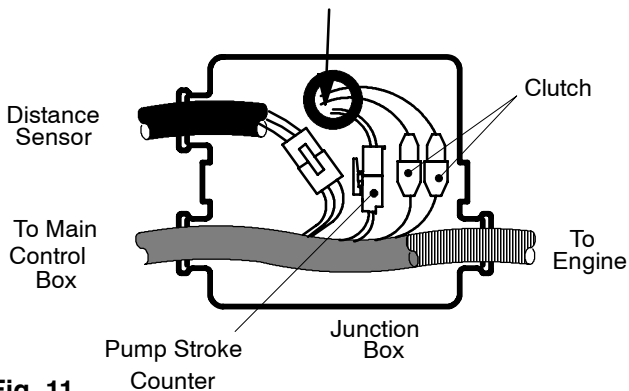
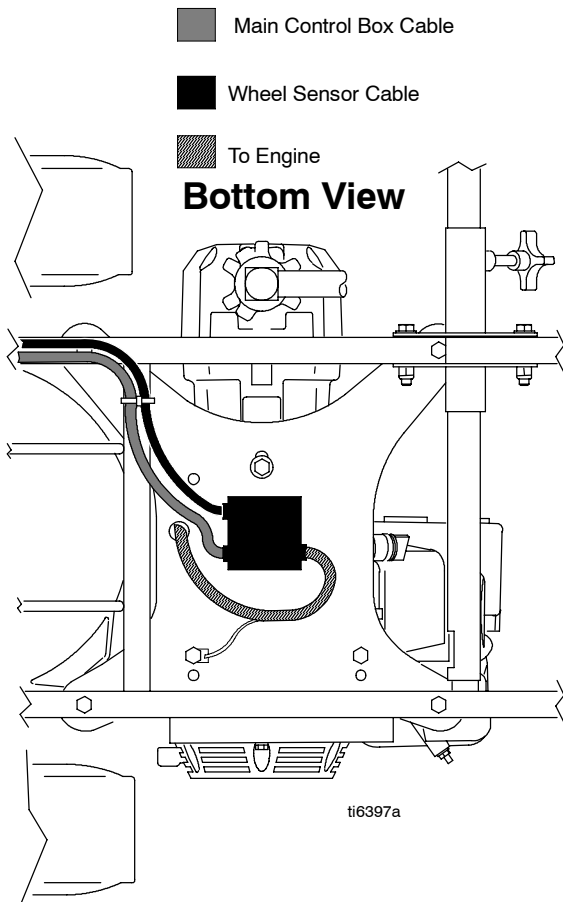

Fig. 11
16 311020

Installation

1. Lift engine carefully and place on cart.
2. Fig. 12. Install two screws (117) and ground conductor (223, 260) in base of engine and secure with locknuts (118). Torque to 20 to 30 ft.-lb.
3. Fig. 11. Connect all necessary wiring.
4. Install **Pinion Assembly/Clutch Armature/Clamp** and **Clutch Housing**. See pages 11 - 15.

Pressure Control

On/Off Switch

Removal



1. Relieve pressure, page 7.
2. Fig. 13. Remove two screws (125) and cover (31).
3. Pull display connector wings (A) open on PC board and pull display connector out.
4. Disconnect ON/OFF switch connector (B) from PC board.
5. Press in on two retaining tabs on each side of ON/OFF switch (15g) and remove switch.

Installation

1. Install ON/OFF switch (15g) so tabs of switch snap into place on inside of pressure control housing.
2. Connect ON/OFF switch connector (B) to PC board.
3. Push display connector into PC board close display connector wings (A) on PC board.
4. Install cover (31) with two screws (125).

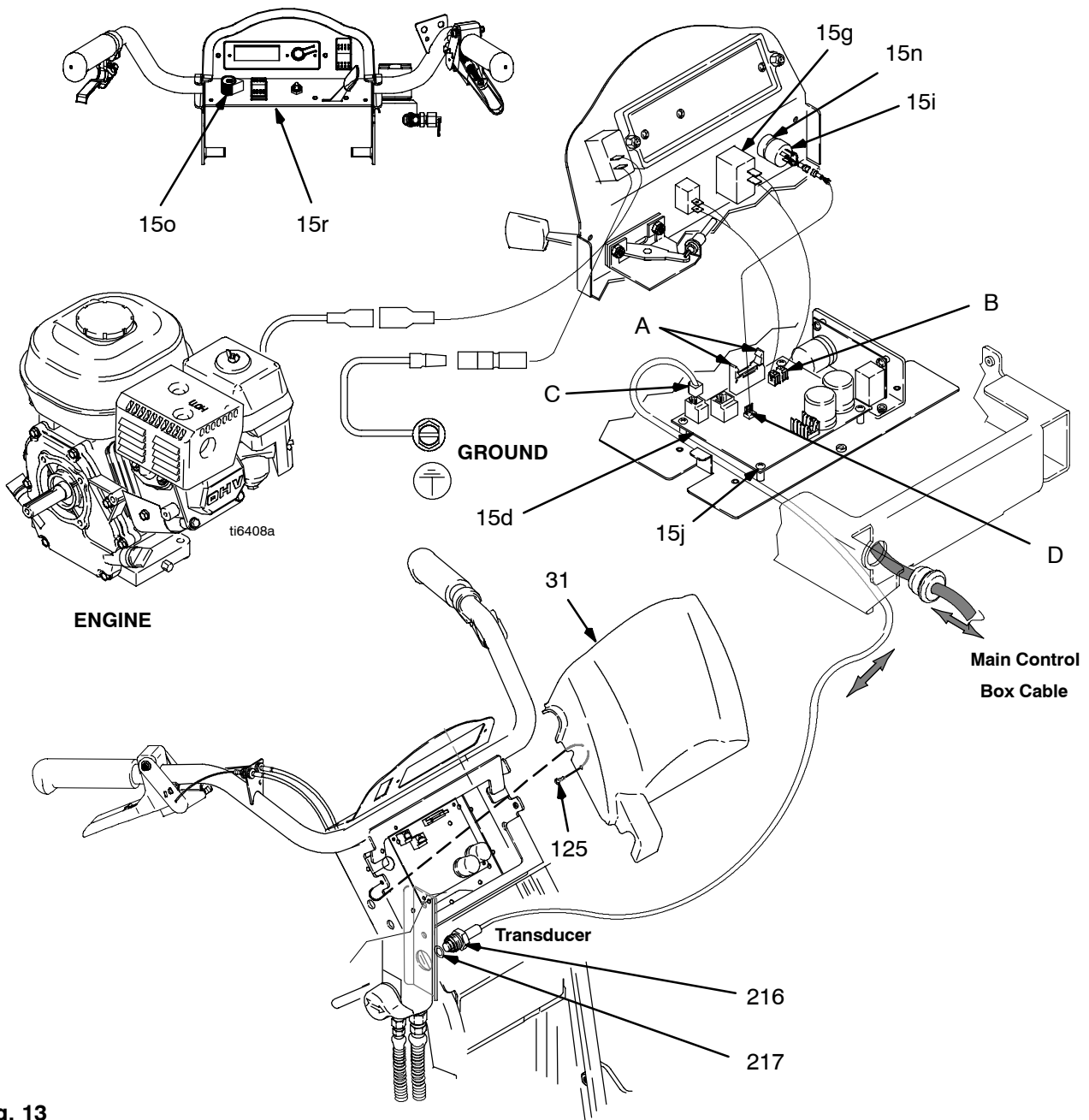

Fig. 13

Pressure Control

Control Board

Removal



1. Relieve pressure, page 7.
2. Fig. 13. Remove two screws (125) and control cover (31). Pull display connector wings open on PC board and pull display connector out.
3. Figs. 13 and 21. Note on a paper lead connections to the control board. Disconnect leads from control board (15d).
4. Fig. 13. Remove four screws (15j) from control board (15d).

Installation

1. Fig. 13. Install control board (15d) with four screws (15j).
2. Figs. 13 and 21. Refer to note on lead connections to the control board. Connect leads to control board (15d).
3. Fig. 13. Push display connector into PC board close display connector wings on PC board. Install control cover (31) with two screws (125).

Pressure Control Transducer

Removal



1. Relieve pressure, page 7.
2. Fig. 13. Remove two screws (125) and control cover (31).
3. Disconnect transducer lead (C) from control board (15d).

4. Remove pressure control transducer (216) and o-ring (217) from filter manifold (40).

Installation

1. Fig. 13. Install o-ring (217) and pressure control transducer (216) in filter manifold (40). Torque to 35–45 ft-lb.
2. Connect transducer lead (C) to control board (15d).
3. Install control cover (31) with two screws (125).

Pressure Adjust Potentiometer

Removal



1. Relieve pressure, page 7.
2. Fig. 13. Remove two screws (125) and control cover (31).
3. Disconnect lead (D) from control board (15d).
4. Loosen set screws on potentiometer knob (15o) and remove knob, shaft nut, lockwasher and pressure adjust potentiometer (15i).
5. Remove seal (15n) from potentiometer (15i).

Installation

1. Install seal (15n) on potentiometer (15i).
2. Fig. 13. Install pressure adjust potentiometer (15i), shaft nut, lockwasher and potentiometer knob (15o).
 - a. Turn potentiometer shaft (15i) clockwise to internal stop. Assemble potentiometer knob (15o) to strike pin on plate (15r).
 - b. After adjustment of step a., tighten both set screws in knob 1/4 to 3/8 turn after contact with shaft.
3. Connect lead (D) to control board (15d).
4. Install control cover (31) with two screws (125).

Trigger Sensor Adjustment

Refer to **Troubleshooting** for trigger sensor adjustment, and see operation manual.

Distance Sensor Adjustment

Gear Alignment



1. Relieve pressure, page 7.
2. Fig. 14. Remove dust cap (142) from wheel. Remove nut (127).
3. Remove wheel (120) from LineLazer.
4. Align gear (67) with sensor.
 - a. Pull gear out from wheel with gear puller.
 - b. Push gear in toward wheel with mallet.

5. Install wheel (120) on LineLazer.
6. Install nut (127) until tight, then back off 1/4 turn. Install dust cap (142) on wheel.

Sensor Height Adjustment

1. Remove wheel (120) from LineLazer.
2. Remove distance sensor (66).
3. Adjust sensor assembly height with two 17 mm nuts of sensor so bottom surface of sensor is 0.638 ± 0.020 from bottom surface of shield. Torque to 8 ± 2 in-lb.
4. Reassemble distance sensor (66) and wheel (82).

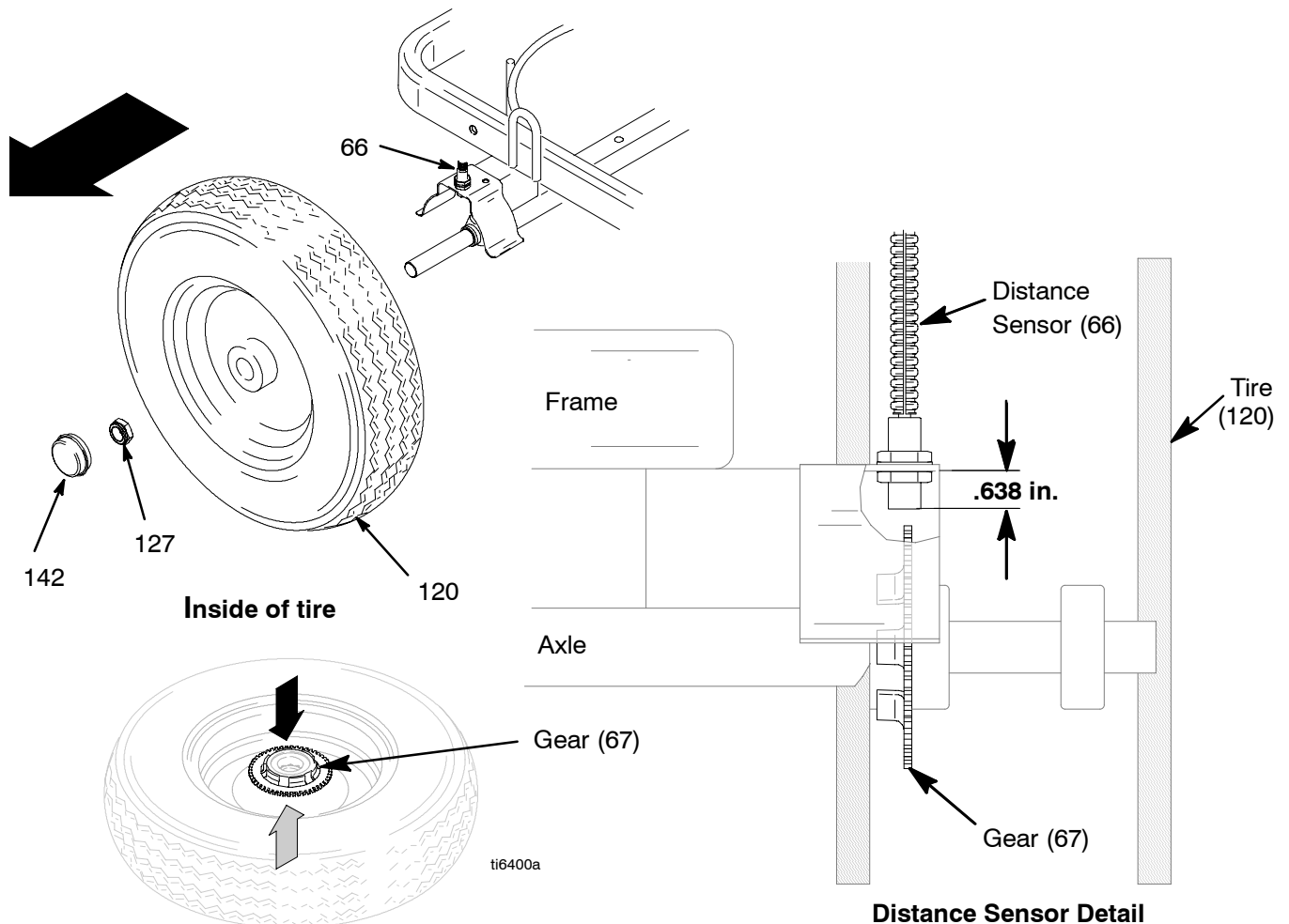

Fig. 14

Control Board Diagnostics

Digital Display Messages



Relieve pressure before repair; page 7. No display does not mean that sprayer is not pressurized.

DISPLAY	SPRAYER OPERATION	INDICATION	ACTION
No Display	Sprayer may be pressurized.	Loss of power or display not connected	Check power source. Relieve pressure before repair or disassembly. Verify display is connected.
----	Sprayer may be pressurized.	Pressure less than 200 psi (14 bar, 1.4 MPa)	Increase pressure as needed
3000 psi 210 bar 21 MPa	Sprayer is pressurized. Power is applied. (Pressure varies with tip size and pressure control setting.)	Normal operation	Spray
E-02	Sprayer stops. Engine is running.	Exceeded pressure limit	Remove any filter clogs or flow obstructions. Make sure gun trigger is locked open if using Auto-Clean valve.
E-03	Sprayer stops. Engine is running.	Pressure transducer faulty, bad connection or broken wire.	Check transducer connections and wire. Replace transducer or control board, if necessary.
E-05	Sprayer stops. Engine is running.	High clutch current	<ol style="list-style-type: none"> 1. Check clutch 7-pin bulkhead connector. Clean contacts. 2. Measure $1.2 \pm 0.2\Omega$ (LineLazer IV 3900); $1.7 \pm 0.2\Omega$ (LineLazer IV 5900) across clutch field at 70°F 3. Replace clutch field assembly

After a fault, follow these steps to restart sprayer:

1. Correct fault condition
2. Turn sprayer OFF
3. Turn sprayer ON

Displacement Pump

Removal

1. Flush pump.



2. Relieve pressure, page 7.
3. Fig. 15. Cycle pump piston rod (A) to lowest position.
4. Fig. 15. Remove suction tube (34) and hose (100).

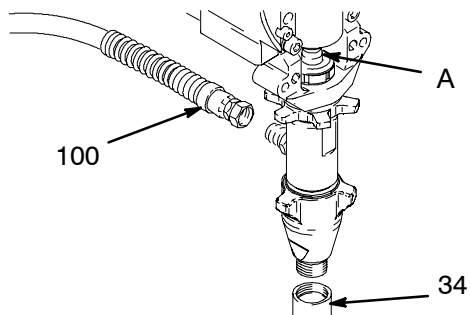

Fig. 15

7672C

Repair

See manual 310643 for pump repair instructions.

Installation

⚠ WARNING

If pin works loose, parts could break off due to force of pumping action. Parts could project through the air and result in serious injury or property damage. Make sure pin and retaining spring are properly installed.

CAUTION

If the pump locknut loosens during operation, the threads of the bearing housing will be damaged. Make sure locknut is properly tightened.

1. Fig. 18. Pull piston rod out 1.5 in. Screw in pump until holes in bearing cross link and piston rod align.

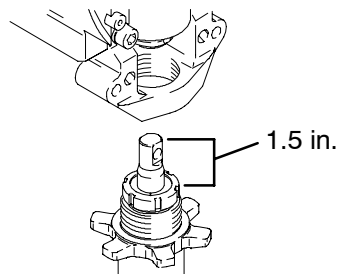

Fig. 18

7676B

5. Fig. 16. Use screwdriver: push retaining spring up and push out pin (235).

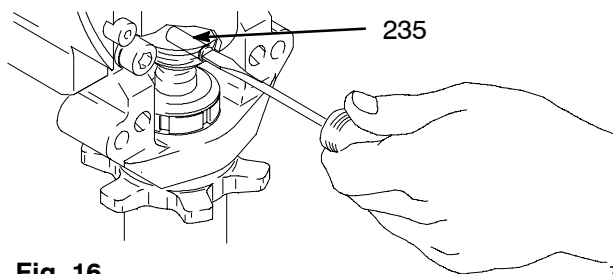

Fig. 16

7675B

6. Fig. 17. Loosen locknut by hitting firmly with a 20 oz (maximum) hammer. Unscrew pump.

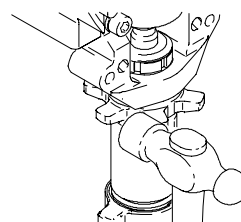

Fig. 17

7673B

2. Fig. 16. Push pin (235) into hole. Push retaining spring into groove around connecting rod.

Fig. 19. Screw jam nut down onto pump until nut stops. Screw pump up into bearing housing until it is stopped by jam nut. Back off pump and jam nut to align pump outlet to back. Tighten jam nut by hand, then tap 1/8 to 1/4 turn with a 20 oz (maximum) hammer to approximately 75 ± 5 ft-lb (102 N·m).

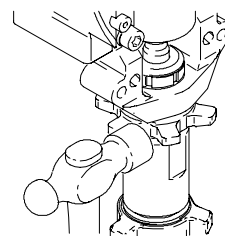

Fig. 19

7673B

Fig. 20. Fill packing nut with Graco TSL until fluid flows onto the top of seal.

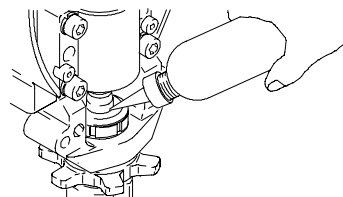
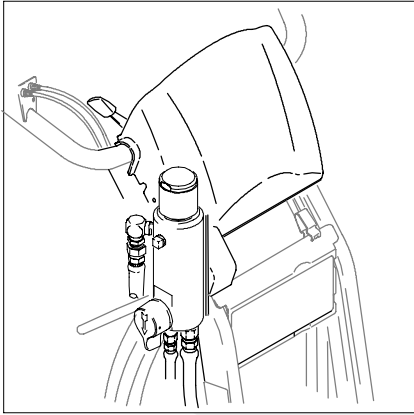

Fig. 20

7677B

Parts - LineLazer IV

Parts Page 32



Parts Page 26

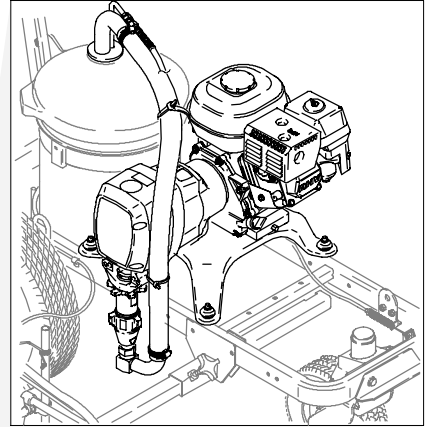

Parts Page 30

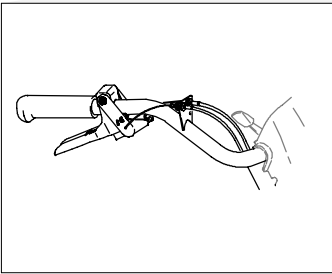

Parts Page 28

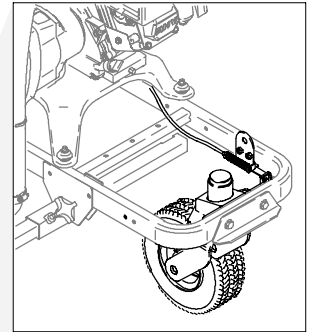

Parts Page 24

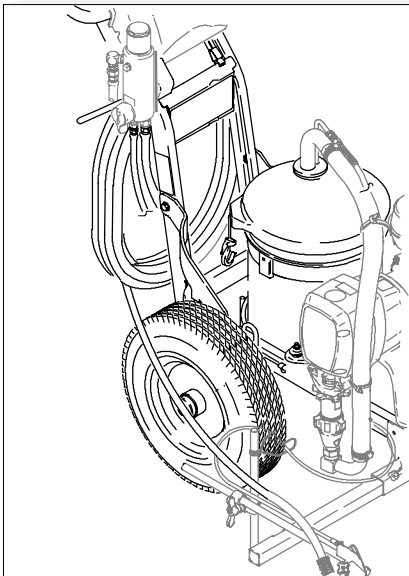

Parts Page 30

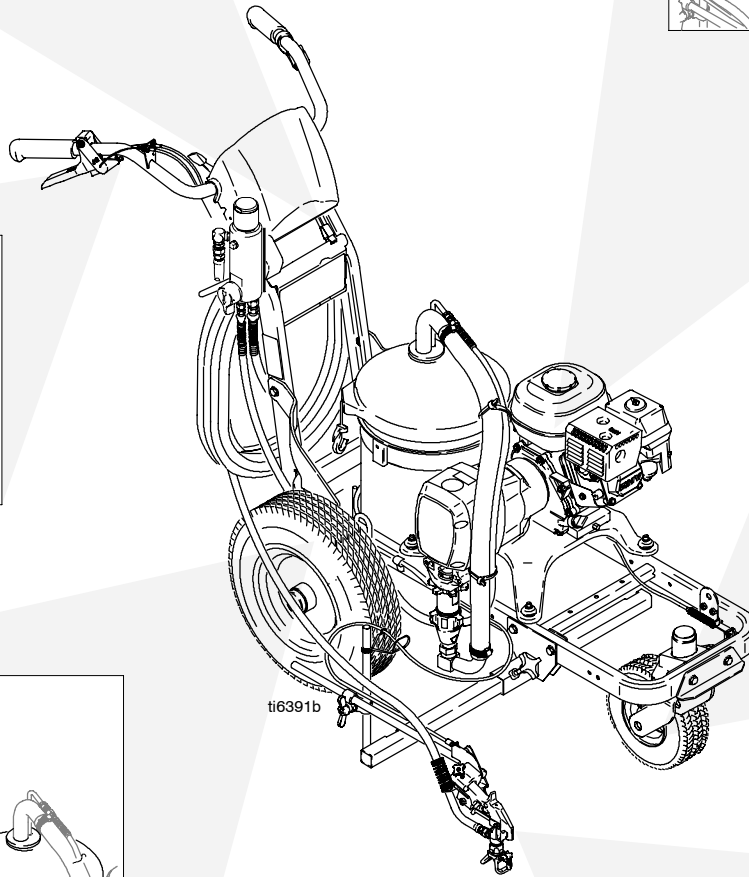
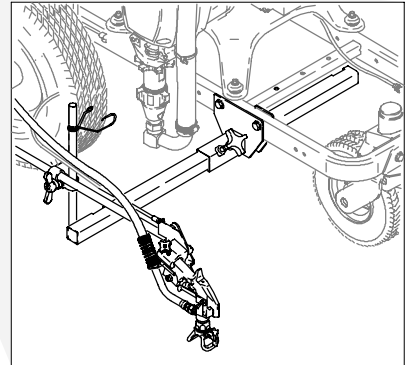

Parts - Drive and Pinion Housing Assemblies

Ref No. 24 and 25

Ref No. 24: Drive Housing Assembly 287467 for LineLazer IV 3900; Drive Housing Assembly 287469 for LineLazer IV 5900

Ref No. 25: Pinion Housing Assembly 287463 for LineLazer IV 3900; Pinion Housing Assembly 287465 for LineLazer IV 5900

Ref No.	Part No.	Description	Qty	Ref No.	Part No.	Description	Qty
24	287467	HOUSING, drive (3900)	1	25	287463	HOUSING, pinion (3900)	1
	287469	HOUSING, drive (5900)	1		287465	HOUSING, pinion (5900)	1
24g		WASHER		25a		KIT, repair, coil	
	107089	LineLazer IV 3900	1		287474	LineLazer IV 3900	1
	194173	LineLazer IV 5900	1		287476	LineLazer IV 5900	1
24h		WASHER		25b	105489	PIN	2
	116191	LineLazer IV 3900	1	25d*		PINION SHAFT	
	116192	LineLazer IV 5900	1		241110	LineLazer IV 3900	1
					241114	LineLazer IV 5900	1
				25e*		RETAINING RING, large	
					113094	LineLazer IV 3900	1
					112770	LineLazer IV 5900	1
				158	114528	SCREW, machine	2
				181	116618	MAGNET	1
				182	119562	SWITCH, reed w/connector	1

*Must be ordered separately.

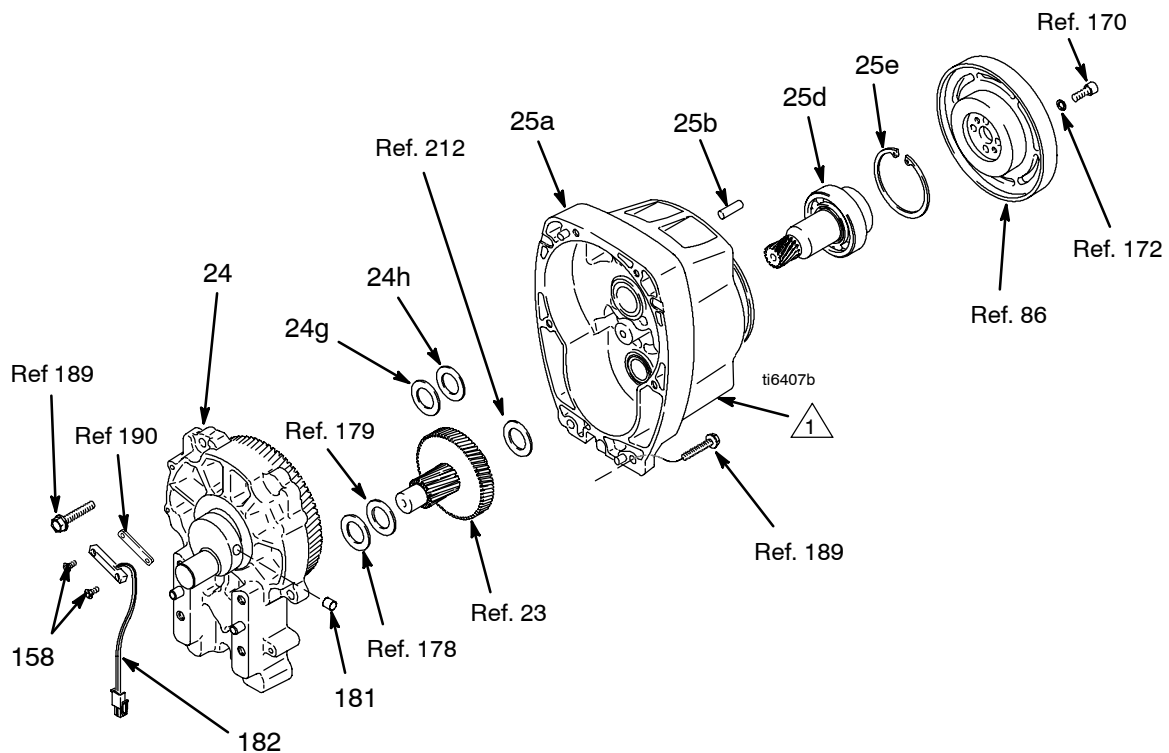

△ Pinion housing assembly (25) includes clutch field and connector

Parts - LineLazer IV

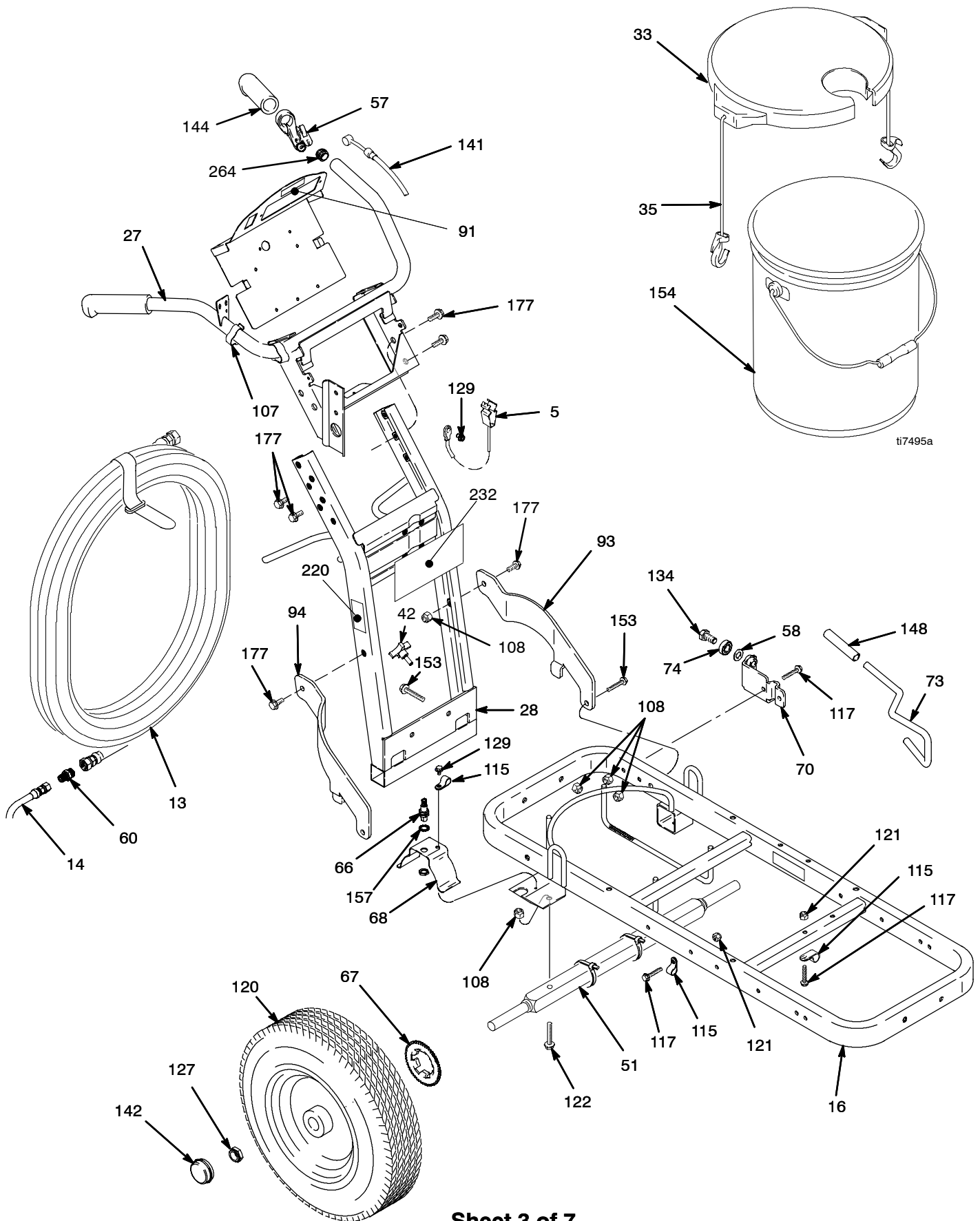

Sheet 3 of 7

Parts - LineLazer IV

Ref. No.	Part No.	Description	Qty.	Ref. No.	Part No.	Description	Qty.
5	237686	WIRE, ground assembly w/ clamp	1	115	108868	CLAMP, wire	3
13	245225	HOSE, 3/8 X 50 ft	1	117	110837	SCREW, flange, hex	3
14	245798	HOSE, 1/4 X 7 ft	2	120	255162	WHEEL, pneumatic	2
16	287623	FRAME, linestriper (painted)	1		249082	WHEEL, turf (models 24M605, 24M607)	2
27	287417	HANDLE	1	121	111040	NUT, lock, insert, nylock, 5/16	3
28	287622	SUPPORT, handle (painted)	1	122	111194	SCREW, cap flang hd	2
33	287590	KIT, pail cover, includes 35	1	127	112405	NUT, lock	2
	240926	KIT, Euro pail cover, no 35	1	129	112798	SCREW, thread forming, hex hd	2
35	119771	STRAP, cover	2	134	113961	SCREW, cap, hex hd	1
42	108471	KNOB, pronged	1	141	241445	CABLE, caster	1
51	193405	AXLE	1	142	114648	CAP, dust	2
57	194310	LEVER, actuator	1	144	114659	GRIP, handle	2
58	195134	SPACER, ball, guide	1	148	114808	CAP, vinyl	1
60	196176	ADAPTER, nipple	1	153	114982	SCREW, cap, flng hd	4
66	287698	KIT, sensor, distance, includes 68,115, 129, 157	1	154	115077	PAIL, plastic	1
				157	116287	WASHER, sst, external	1
67	245734	GEAR, distance, includes 120	1	158	114528	SCREW, mach, phillips, pnhd	2
68	198612	SHIELD, sensor, distance	1	177	112395	SCREW, cap, flnghd	6
70	198891	BRACKET, mounting	1	181	116618	MAGNET	1
73	198930	ROD, brake	1	182	119562	SWITCH, reed, with connector	1
74	198931	BEARING	1	220▲	15F638	LABEL, GMAX warning fire& skn	1
91	189919	KIT, label, blank	2	232	15F545	LABEL, brand, handle	1
93	15F577	BRACE, left (painted)	1		16N453	LABEL, brand, handle (models 24M605, 24M607)	1
94	15F576	BRACE, right (painted)	1				
107	178342	CLIP	2	264	120151	PLUG, tube	2
108	101566	NUT, lock	8	265	241104	HOPPER, 15 gal (models 24M605)	1

Parts - LineLazer IV

Models 248862 and 248866

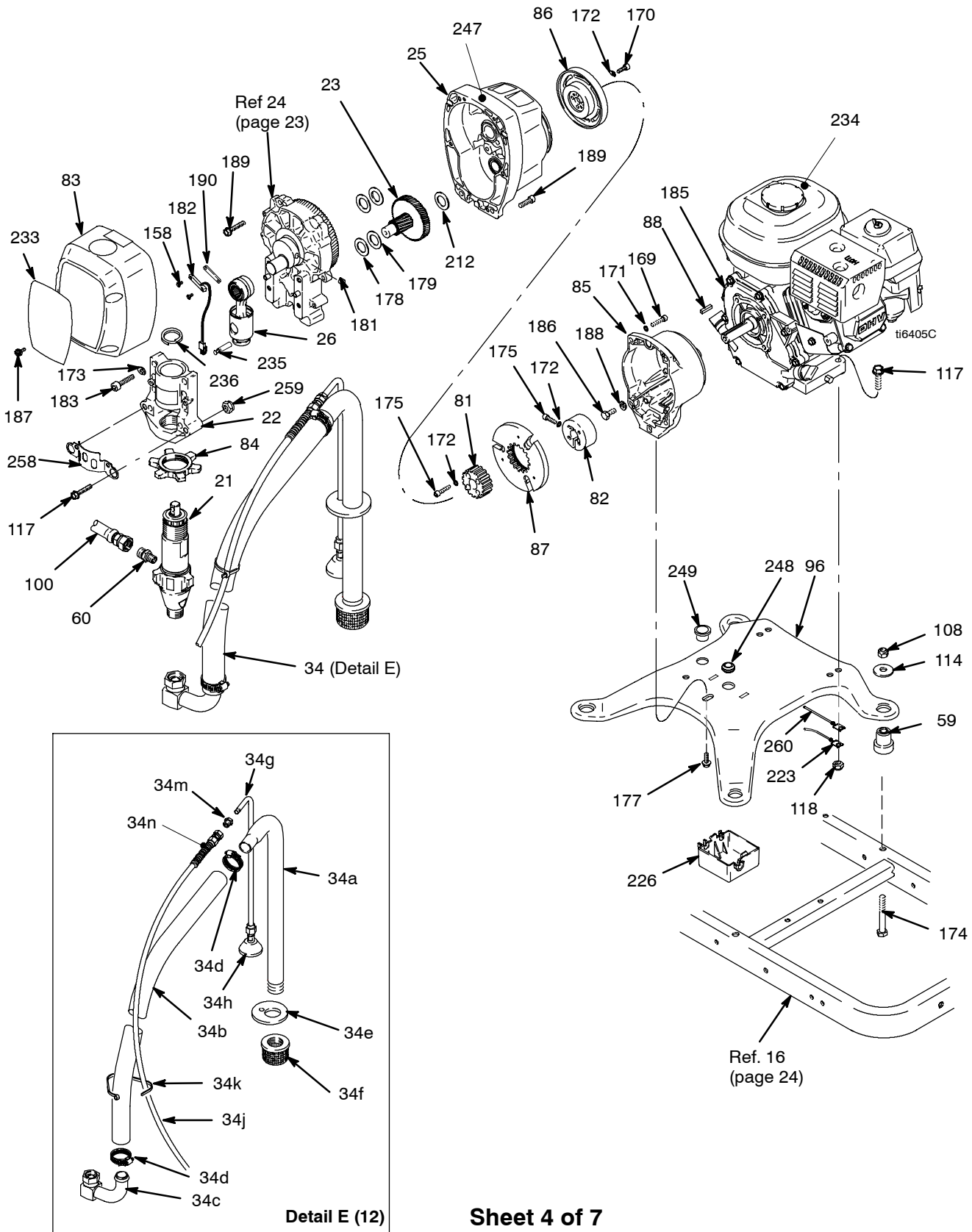

Parts - LineLazer IV

Ref. No.	Part No.	Description	Qty.	Ref. No.	Part No.	Description	Qty.
21	277069	PUMP, displacement (3900)	1	169	119426	SCREW, hex washr hd (3900)	4
	277070	PUMP, displacement (5900)	1		102962	SCREW, cap sch (5900)	4
22	287714	HOUSING, bearing (3900)	1	170†	101682	SCREW, cap, sch	4
	287715	HOUSING, bearing (5900)	1	171	104008	WASHER, lock, spring (5900)	4
23	287653	GEAR, combination (3900)	1	172†	105510	WASHER, lock, spr (hi-collar)	10
	287460	GEAR, combination (5900)	1	173		WASHER, lock, spr (hi-collar)	
26‡	287719	ROD, connecting (3900)	1		100214	(3900)	4
	287720	ROD, connecting (5900)	1		106115	(5900)	4
34	245730	HOSE ASSEMBLY, drain (items 34a thru 34n)	1	174	113743	SCREW, cap, hex hd	4
34a	170957	TUBE, suction	1	175†	108803	SCREW, hex, socket head	6
34b	185381	HOSE	1	177	112395	SCREW, cap, flnghd	1
34c	110194	SWIVEL, 180°	1	178	114672	WASHER, thrust	1
34d	101818	CLAMP, hose	1	179	114699	WASHER, thrust	1
34e	15F513	GASKET, pail	1	183	113467	SCREW, cap, soc hd (3900)	4
34f	181072	STRAINER	1		114666	SCREW, cap, soc hd (5900)	4
34g	245731	TUBE, drain (includes diffuser)	1	185	108879	ENGINE, gas, 4.0 hp (3900)	1
34h	241920	DIFFUSER	1		114530	ENGINE, gas, 5.5 hp (5900)	1
34j	245798	HOSE, coupled, 1/4 in. x 7 ft	1	186	108842	SCREW, cap, hex hd	4
34k	114958	STRAP, tie	2	187	118444	SCREW, machine hex washer hd	4
34m	196180	BUSHING	1	188	100214	WASHER, lock	4
34n▲	195119	LABEL, warning	1	189	119426	SCREW, mach, hex washr hd (3900)	8
59	119695	DAMPENER, engine mount	4		15C753	SCREW, mach, hex washr hd (5900)	6
60	196176	ADAPTER, nipple	1	190	15F947	SHIELD, magnetic	1
81†		HUB, armature	1	212	15F250	WASHER, thrust (3900)	1
82	193680	COLLAR, shaft	1		114672	WASHER, thrust (5900)	1
83	287521	COVER, front (3900)	1	223	119579	CONDUCTOR, ground (3900)	1
	287511	COVER, front (5900)	1		240997	CONDUCTOR, ground (5900)	1
84	192723	NUT, retaining (3900)	1	226	287695	BOX	1
	193031	NUT, retaining (5900)	1	233	15F546	LABEL, brand (3900)	1
85	15E535	HOUSING, clutch (3900)	1		15F547	LABEL, brand (5900)	1
	15E277	HOUSING, clutch (5900)	1		16N452	LABEL, brand, (R300) (models 24M605, 24M607)	1
86†		ROTOR, clutch, 4 in. (3900)	1	234▲	194126	LABEL, warning	1
		ROTOR, clutch, 5 in. (5900)	1	235		PIN, pump	
87†		ARMATURE, clutch, 4 in. (3900)	1		15F855	(3900)	1
		ARMATURE, clutch, 5 in. (5900)	1		15F856	(5900)	1
88	183401	KEY, parallel	1	236‡	119676	SPRING, retaining (3900)	1
96	15F583	PLATE, engine mount	1		119778	SPRING, retaining (5900)	1
100	245797	HOSE, 3/8 in. x 3.0 ft	1	247	290228	LABEL, caution	1
108	101566	NUT, lock	2	248	114629	GROMMET	1
114	108851	WASHER, plain	8	249	119569	BUSHING	1
117	110837	SCREW, flange, hex	2	258	15C762	SHIELD, pump rod	1
118	110838	NUT, lock	2	259	110996	NUT, hex	2
				260	240997	CONDUCTOR, ground (5900)	1

▲ Replacement warning labels may be ordered free of charge

† Included in Clutch Repair Kits 241109 (3900) and 241113 (5900)

‡ Included in Connecting Rod Kits

Parts - LineLazer IV

Models 248862 and 248866

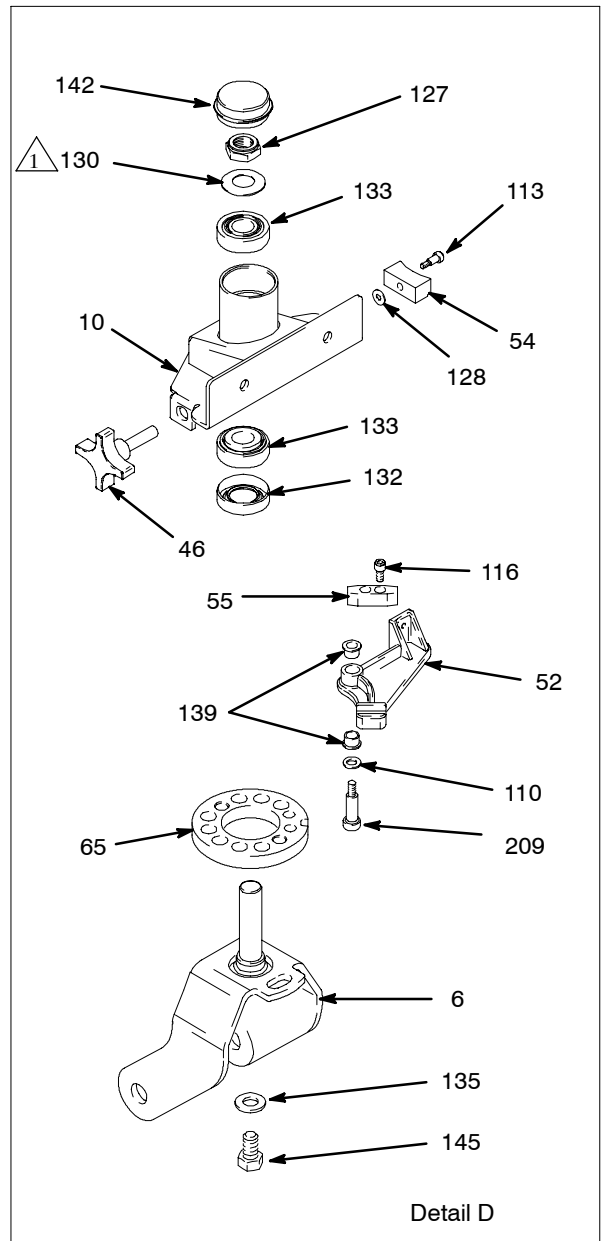
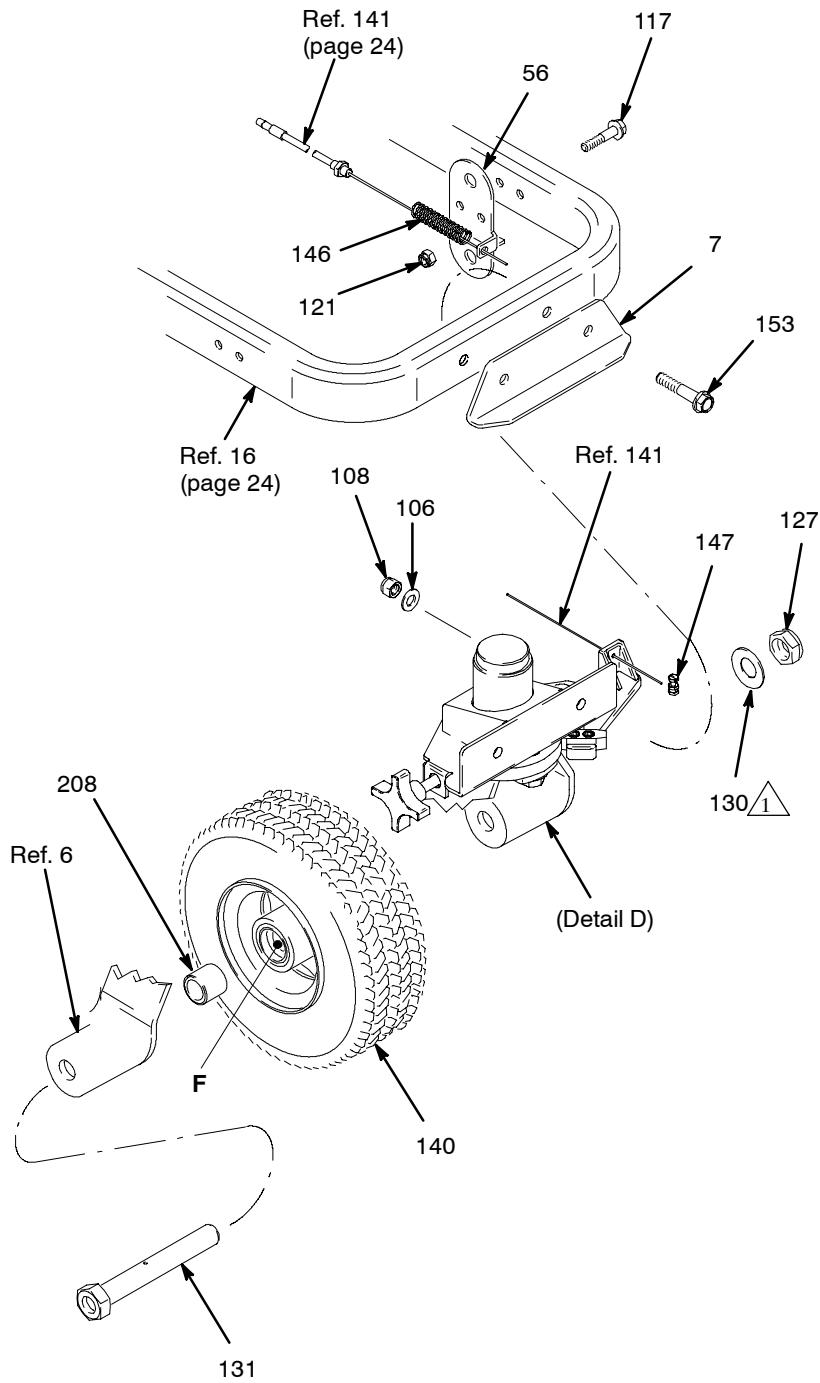

ti6404b

¹ Install washers (130) concave surface to inside.

Parts - LineLazer IV

Ref. No.	Part No.	Description	Qty.	Ref. No.	Part No.	Description	Qty.
6	240942	SHAFT, fork	1	128	112776	WASHER, plain	1
7	240991	BRACKET, caster, front	1	130	112825	SPRING, belleville	3
10*	15G952	BRACKET	1	131	113471	SCREW, cap, hex hd	1
46	181818	KNOB, pronged	1	132*	113484	SEAL, grease	1
52	193528	ARM, detent	1	133*	113485	BEARING, cup/cone	2
54	193661	JAW,	1	135	113962	WASHER, hardened, SAE	1
55	193662	STOP, wedge	1	139	114548	BEARING, bronze	2
56	15F910	BRACKET, cable	1	140	114549	WHEEL, pneumatic	1
65	198606	DISK, adjuster	1	142	114648	CAP, dust	1
106	100731	WASHER,	2	145	114681	SCREW, cap, hex hd	1
108	101566	NUT, lock	2	146	114682	SPRING, compression	1
110	15J603	WASHER, plain	1	147	114802	STOP, wire	1
113	108483	SCREW, shoulder, sch	1	153	114982	SCREW, cap, flng hd	2
116	110754	SCREW, cap, sch	2	208	193658	SPACER, seal	2
117	110837	SCREW, flange, hex	2	209*	120476	BOLT	1
121	111040	NUT, lock, insert, nylock, 5/16	2				
127	112405	NUT, lock	2				

* Included in 240940 Bracket Repair Kit; purchase separately

Parts - LineLazer IV

Models 248862 and 248866

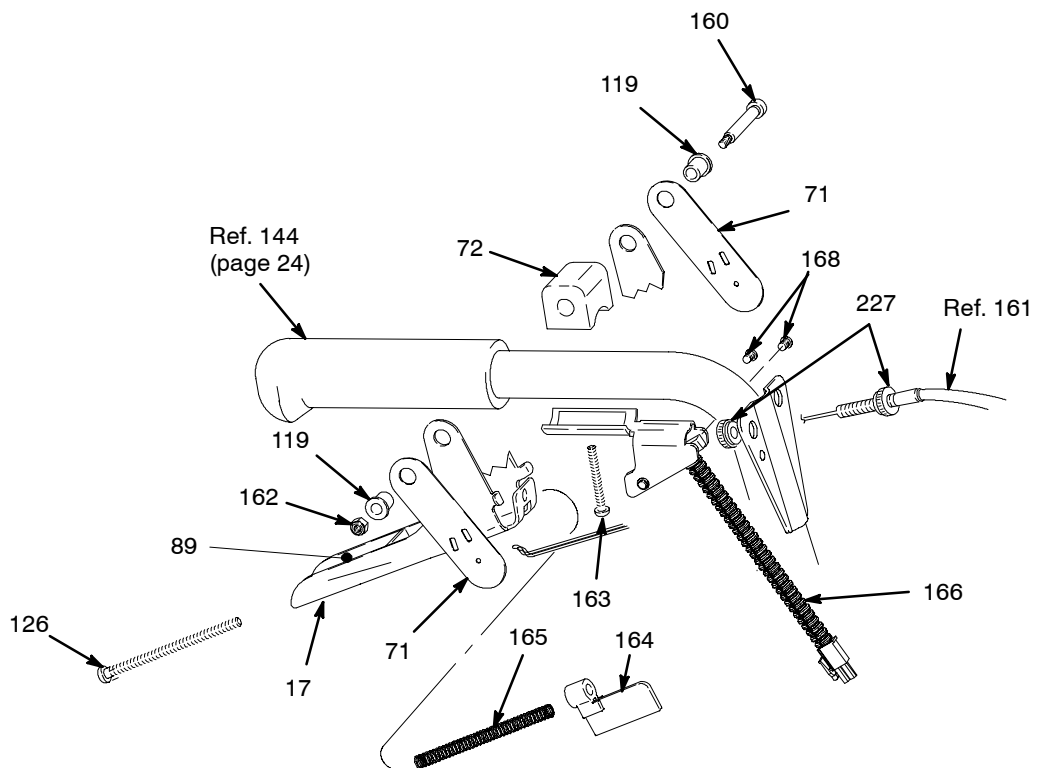
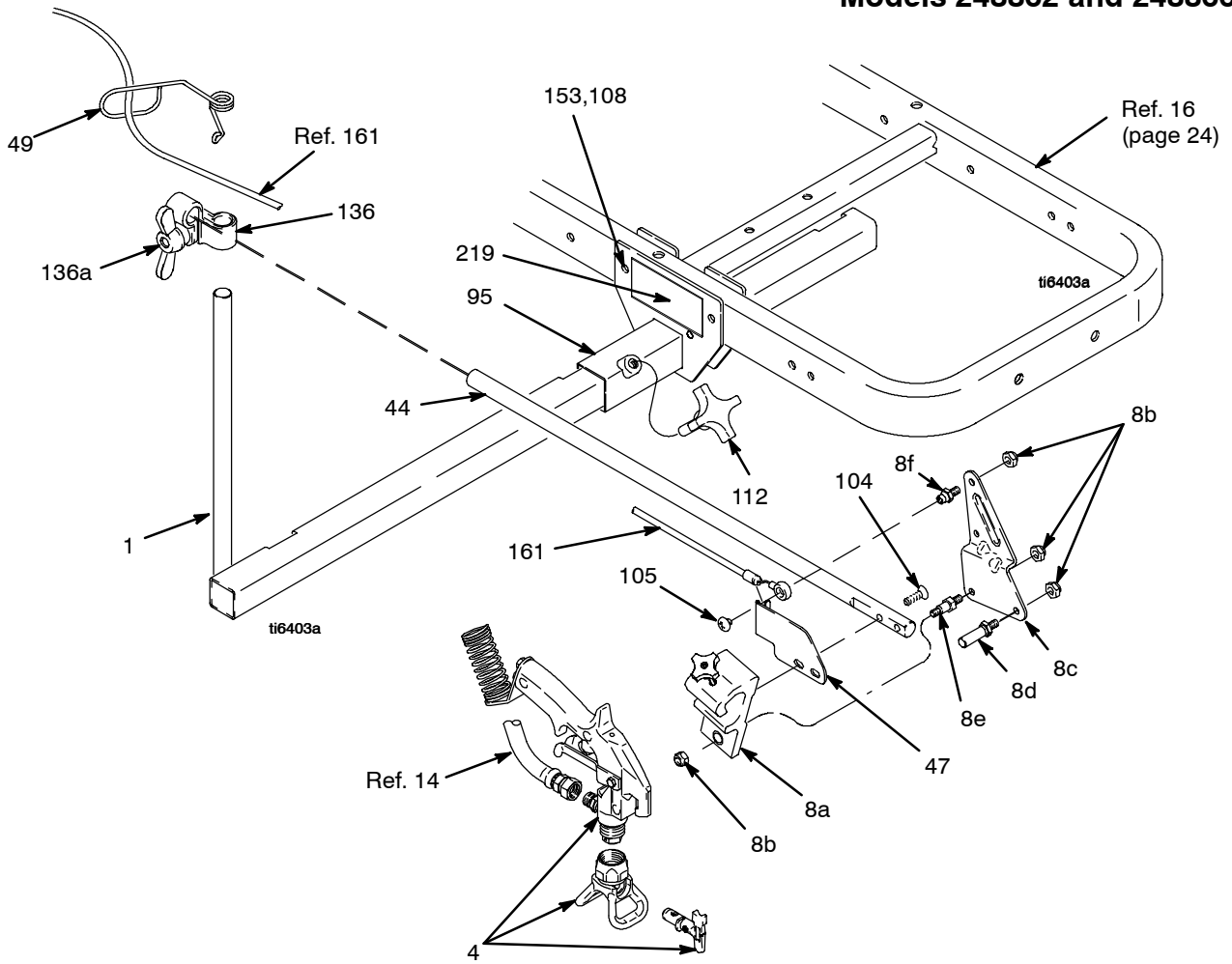

Sheet 6 of 7

Parts - LineLazer IV

Ref. No.	Part No.	Description	Qty.	Ref. No.	Part No.	Description	Qty.
1	224052	BRACKET, support gun	1	105	119648	SCREW, mach, trusshd	1
4	248157	GUN, flex, basic, includes guard & tip	1	108	101566	NUT, lock	2
8	287570	HOLDER ASSEMBLY, gun (items 8a thru 8f)	1	112	111145	KNOB, pronged	1
8a	287569	HOLDER, GUN	1	119	111017	BEARING, flange	2
8b	102040	NUT, lock	4	126*	112381	SCREW, mach, pan hd	1
8c	15F214	LEVER, actuator	1	136	287566	KIT, clamp, includes 136a	1
8d	15F209	STUD, pull, trigger	1	136a	114028	NUT, wing	1
8e	15F210	STUD, pivot	1	153	114982	SCREW, cap, flng hd	2
8f	15F211	STUD, cable	1	160	116941	SCREW, shoulder, socket head	1
17*	245733	KIT, trigger handle repair (includes items 17, 89, 126, 164 and 165)	1	161	287696	CABLE, gun, includes 227	1
44	15F212	ARM, holder, gun	1	162	116969	NUT, lock	1
47	15F213	BRACKET, cable	1	163	116973	SCREW, #10 taptite phil	1
49	188135	GUIDE, cable	1	164*	117268	BRACKET, interrupter	1
71	198895	PLATE, lever, pivot	2	165*	117269	SPRING	1
72	198896	BLOCK, mounting (mach)	1	166	287699	SENSOR, trigger	1
89*	15A644	LABEL, trigger	1	168	117317	SCREW, plastite, pan head	2
95	15F389	BRACKET, gun arm	1	219▲	15F637	LABEL, GMAX warning skn injct	1
104	119647	SCREW, cap, socket, flthd	2	227	15F624	NUT, cable, gun (knurled)	2

* Included in Trigger Repair Kit 245733

Parts - LineLazer IV

Models 248862 and 248866

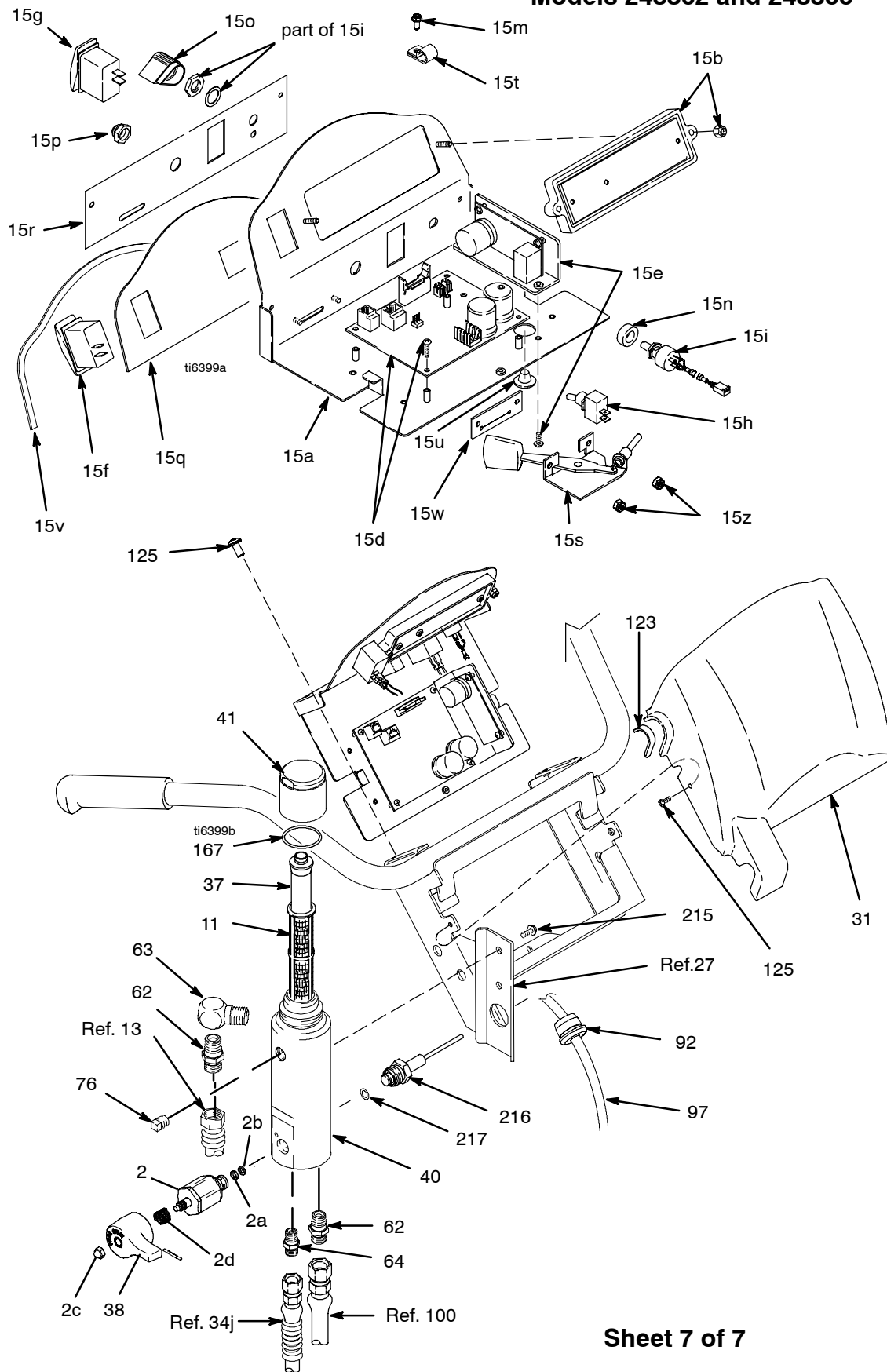

Sheet 7 of 7

Parts - LineLazer IV

Ref. No.	Part No.	Description	Qty.	Ref. No.	Part No.	Description	Qty.
2	245103	VALVE, drain	1	15v	15F777	GASKET, control	1
2a	193709	SEAT, valve	1	15w	15F776	GASKET, throttle	1
2b	193710	SEAT, valve	1	15z	109466	NUT, lock, hex	2
2c	116424	NUT, cap	1	31	15F589	COVER, control	1
2d	114708	SPRING	1	37*	15C766	TUBE, diffusion	1
11	244067	FILTER, fluid	1	38*	15G563	HANDLE,	1
15a	15F272	PLATE, control	1	40*	15H561	MANIFOLD, filter, 3/8 npt	1
15b	287688	KIT, display board	1	41*	287285	KIT, repair, filter cap, includes 37, 167	1
15d	287689	BOARD, control	1	62*	196178	ADAPTER, nipple	2
15e	287690	BOARD, light	1	63*	196179	FITTING, elbow, street	1
15f	114954	SWITCH, rocker	1	64	196181	FITTING, nipple	1
15g	116752	SWITCH, rocker	1	76	15G331	PLUG, pipe	1
15h	119541	SWITCH, toggle	1	92	111348	BUSHING, relief, strain	1
15i	241443	POTENTIOMETER KIT	1	97	15E910	WIRE, harness	1
15m	116719	SCREW, 8-32, hx hd	3	123	15F814	GASKET	2
15n	198650	SPACER, shaft	1	125	116719	SCREW, 8-32, hex washer hd	5
15o	116167	KNOB, potentiometer	1	167*	117285	PACKING, o-ring	1
15p	195428	BOOT, toggle	1	215	111801	SCREW, cap, hex hd	2
15q	15F543	LABEL, control, top	1	216*	287172	TRANSDUCER, pressure control	1
15r	15F544	LABEL, control, bottom	1	217*	111457	PACKING, o-ring	1
15s	287692	KIT, control, throttle	1				
15t	119736	CLAMP, cable	1				
15u	119737	PLUG	1				

▲ Replacement warning labels may be ordered free of charge

* Included in Filter Repair Kit 288100

Pressure Control Wiring Diagram

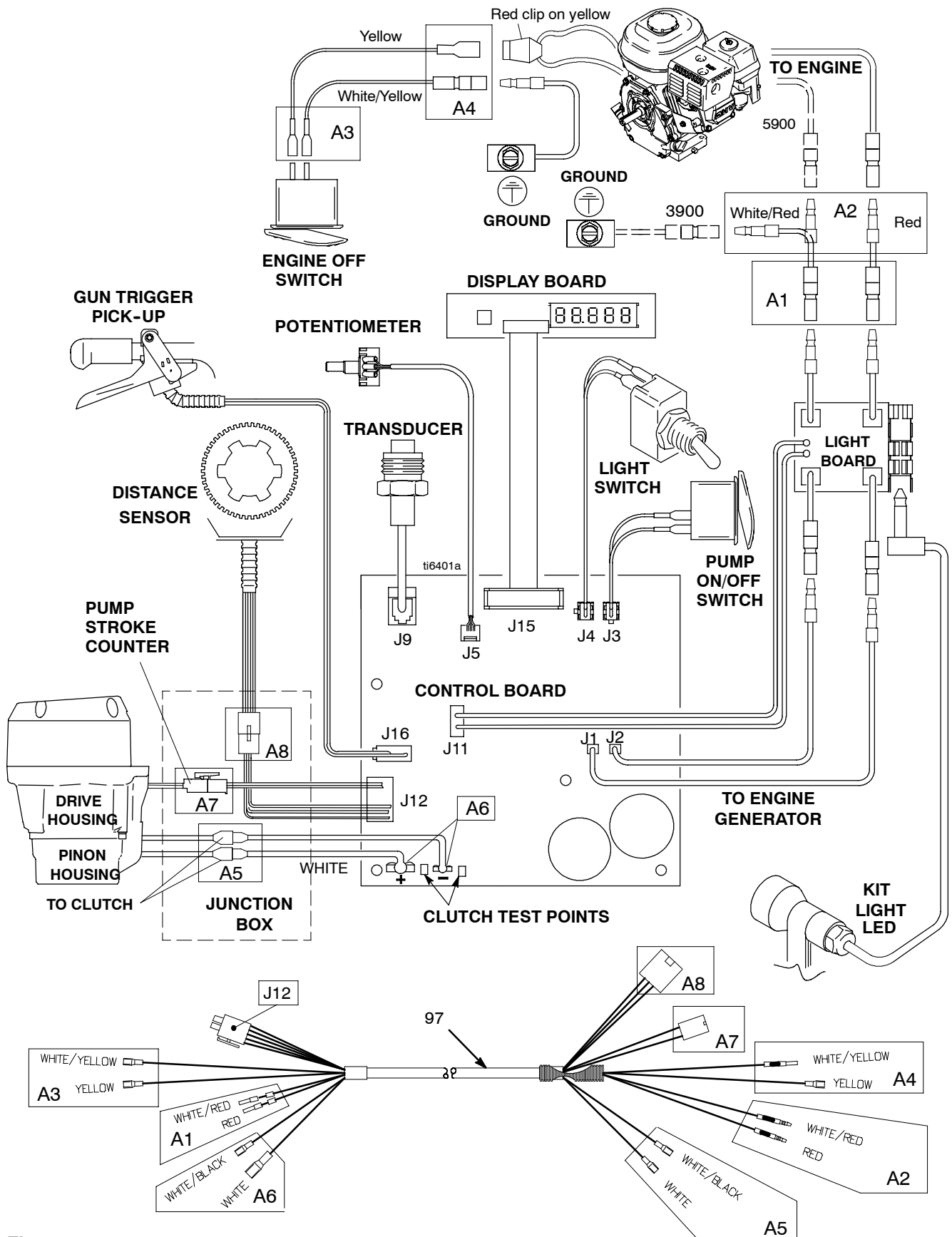

Fig. 21

Technical Data

Honda GX120 Engine	
Power Rating @ 3600 rpm	
ANSI	4.0 Horsepower
DIN 6270B/DIN 6271	
NA	2.1 Kw - 2.8 Ps
NB	2.6 Kw - 3.6 Ps
Honda GX160 Engine	
Power Rating @ 3600 rpm	
ANSI	5.5 Horsepower
DIN 6270B/DIN 6271	
NA	2.9 Kw - 4.0 Ps
NB	3.6 Kw - 4.9 Ps
Maximum working pressure	3300 psi (228 bar, 22.8 MPa)
Noise Level	
Sound power	105 dBA per ISO 3744
Sound pressure	96 dBA measured at 3.1 feet (1 m)
*Vibration Level	
LineLazer IV 3900	
Left hand	1.81 m/sec ²
Right hand	1.45 m/sec ²
LineLazer IV 5900	
Left hand	2.05 m/sec ²
Right hand	1.70 m/sec ²
*Vibration measured per ISO 5349 based on 8 hour daily exposure	

Maximum delivery	
LineLazer IV 3900	1.15 gpm (4.4 liter/min)
LineLazer IV 5900	1.5 gpm (5.7 liter/min)
Maximum tip size	
LineLazer IV 3900	1 gun with 0.034 in. tip 2 guns with 0.024 in. tip
LineLazer IV 5900	1 gun with 0.041 in. tip 2 guns with 0.028 in. tip
Inlet paint strainer	16 mesh (1190 micron) stainless steel screen, reusable
Outlet paint filter	60 mesh (250 micron) stainless steel screen, reusable
Pump inlet size	3/4 in. npt (m)
Fluid outlet size	1/4 npsm from fluid filter
Wetted parts	nickel-plated carbon steel, PTFE, Nylon, polyurethane, UHMW polyethylene, fluoroelastomer, acetal, leather, tungsten carbide, stainless steel, chrome plating

Dimensions

LineLazer IV 3900

Model 248862, 249008 Striper

Weight (dry, without packaging)	212 lb (96 kg)
Height	40 in. (101.6 cm)
Length	65 in. (165.1 cm)
Width	32 in. (81.3 cm)

Model 248863, 249009 Striper with 2nd Gun Kit

Weight (dry, without packaging)	222 lb (101 kg)
Height	40 in. (101.6 cm)
Length	65 in. (165.1 cm)
Width	32 in. (81.3 cm)

Model 248864 Striper with Bead

Weight (dry, without packaging)	212 lb (96 kg)
Height	40 in. (101.6 cm)
Length	65 in. (165.1 cm)
Width	32 in. (81.3 cm)

Model 248865 Striper 2nd Gun Kit with Bead

Weight (dry, without packaging)	222 lb (101 kg)
Height	40 in. (101.6 cm)
Length	65 in. (165.1 cm)
Width	32 in. (81.3 cm)

LineLazer IV 5900

Model 248866, 249010 Striper

Weight (dry, without packaging)	232 lb (105 kg)
Height	40 in. (101.6 cm)
Length	65 in. (165.1 cm)
Width	32 in. (81.3 cm)

Model 248867, 249011 Striper with 2nd Gun Kit

Weight (dry, without packaging)	242 lb (110 kg)
Height	40 in. (101.6 cm)
Length	65 in. (165.1 cm)
Width	32 in. (81.3 cm)

Model 248868 Striper with Bead

Weight (dry, without packaging)	232 lb (105 kg)
Height	40 in. (101.6 cm)
Length	65 in. (165.1 cm)
Width	32 in. (81.3 cm)

Model 248869 Striper 2nd Gun Kit with Bead

Weight (dry, without packaging)	242 lb (110 kg)
Height	40 in. (101.6 cm)
Length	65 in. (165.1 cm)
Width	32 in. (81.3 cm)

Graco Standard Warranty

Graco warrants all equipment manufactured by Graco and bearing its name to be free from defects in material and workmanship on the date of sale to the original purchaser for use. With the exception of any special, extended, or limited warranty published by Graco, Graco will, for a period of twelve months from the date of sale, repair or replace any part of the equipment determined by Graco to be defective. This warranty applies only when the equipment is installed, operated and maintained in accordance with Graco's written recommendations.

This warranty does not cover, and Graco shall not be liable for general wear and tear, or any malfunction, damage or wear caused by faulty installation, misapplication, abrasion, corrosion, inadequate or improper maintenance, negligence, accident, tampering, or substitution of non-Graco component parts. Nor shall Graco be liable for malfunction, damage or wear caused by the incompatibility of Graco equipment with structures, accessories, equipment or materials not supplied by Graco, or the improper design, manufacture, installation, operation or maintenance of structures, accessories, equipment or materials not supplied by Graco.

This warranty is conditioned upon the prepaid return of the equipment claimed to be defective to an authorized Graco distributor for verification of the claimed defect. If the claimed defect is verified, Graco will repair or replace free of charge any defective parts. The equipment will be returned to the original purchaser transportation prepaid. If inspection of the equipment does not disclose any defect in material or workmanship, repairs will be made at a reasonable charge, which charges may include the costs of parts, labor, and transportation.

THIS WARRANTY IS EXCLUSIVE, AND IS IN LIEU OF ANY OTHER WARRANTIES, EXPRESS OR IMPLIED, INCLUDING BUT NOT LIMITED TO WARRANTY OF MERCHANTABILITY OR WARRANTY OF FITNESS FOR A PARTICULAR PURPOSE.

Graco's sole obligation and buyer's sole remedy for any breach of warranty shall be as set forth above. The buyer agrees that no other remedy (including, but not limited to, incidental or consequential damages for lost profits, lost sales, injury to person or property, or any other incidental or consequential loss) shall be available. Any action for breach of warranty must be brought within two (2) years of the date of sale.

Graco makes no warranty, and disclaims all implied warranties of merchantability and fitness for a particular purpose in connection with accessories, equipment, materials or components sold but not manufactured by Graco. These items sold, but not manufactured by Graco (such as electric motors, switches, hose, etc.), are subject to the warranty, if any, of their manufacturer. Graco will provide purchaser with reasonable assistance in making any claim for breach of these warranties.

In no event will Graco be liable for indirect, incidental, special or consequential damages resulting from Graco supplying equipment hereunder, or the furnishing, performance, or use of any products or other goods sold hereto, whether due to a breach of contract, breach of warranty, the negligence of Graco, or otherwise.

FOR GRACO CANADA CUSTOMERS

The parties acknowledge that they have required that the present document, as well as all documents, notices and legal proceedings entered into, given or instituted pursuant hereto or relating directly or indirectly hereto, be drawn up in English. Les parties reconnaissent avoir convenu que la rédaction du présente document sera en Anglais, ainsi que tous documents, avis et procédures judiciaires exécutés, donnés ou intentés à la suite de ou en rapport, directement ou indirectement, avec les procédures concernées.

ADDITIONAL WARRANTY COVERAGE

Graco does provide extended warranty and wear warranty for products described in the "Graco Contractor Equipment Warranty Program".

Graco Information

TO PLACE AN ORDER, contact your Graco distributor, or call **1-800-690-2894** to identify the nearest distributor.

All written and visual data contained in this document reflects the latest product information available at the time of publication. Graco reserves the right to make changes at any time without notice.

Original instructions. This manual contains English. MM 311020

Graco Headquarters: Minneapolis
International Offices: Belgium, China, Japan, Korea

GRACO INC. AND SUBSIDIARIES P.O. BOX 1441 MINNEAPOLIS, MN 55440-1441 USA
Copyright 2010, Graco Inc. All Graco manufacturing locations are registered to ISO 9001

www.graco.com

Rev. 01/2012