

## LineLazer™ IV 200<sub>HS</sub> Auto-Layout™ System Airless Line Striper

312226P

EN

***For application of line striping materials. For professional use only.  
Not for use in explosive atmospheres.***

*3300 psi (22.8 MPa, 228 bar) Maximum Working Pressure*



### Important Safety Instructions

Read all warnings and instructions in this manual.  
Save these instructions.

See page 2 for model information.



312190



309055



309277



312345



311254



312307

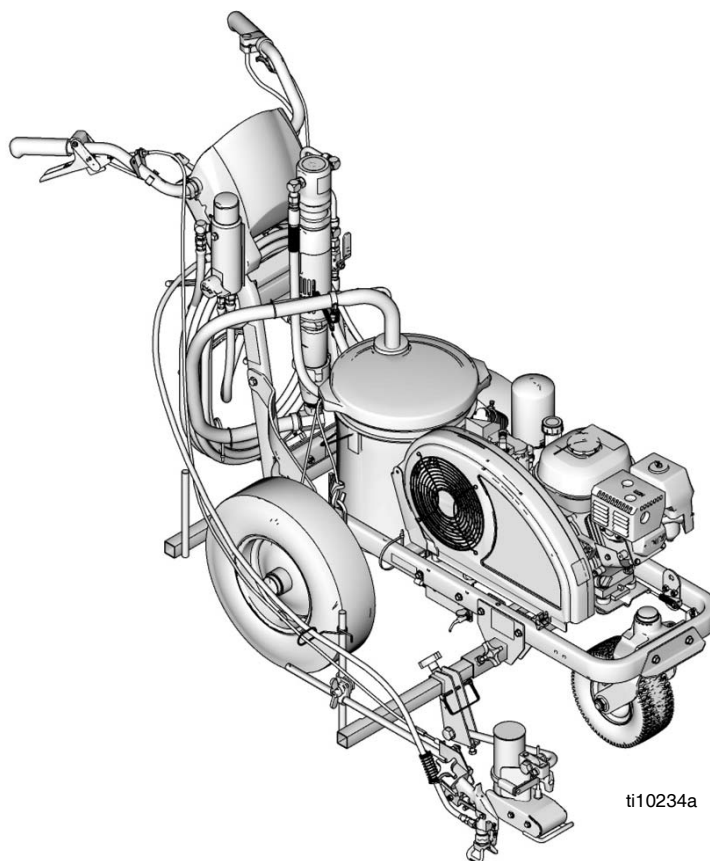





ti10234a



# Contents







<b>Models</b> .....	<b>2</b>	<b>Fan Belt</b> .....	<b>19</b>
<b>Warnings</b> .....	<b>3</b>	<b>Engine</b> .....	<b>20</b>
<b>Tip Selection</b> .....	<b>5</b>	<b>Hydraulic Motor Rebuild</b> .....	<b>21</b>
<b>General Repair Information</b> .....	<b>6</b>	<b>Oil/Filter Change</b> .....	<b>23</b>
<b>Maintenance</b> .....	<b>7</b>	<b>Gallon Counter</b> .....	<b>23</b>
<b>Troubleshooting</b> .....	<b>8</b>	<b>Displacement Pump</b> .....	<b>24</b>
<b>Auto-Layout Can Actuator Adjustment</b> .....	<b>12</b>	<b>Parts</b> .....	<b>25</b>
<b>Auto-Layout System</b> .....	<b>13</b>	<b>Auto-Layout System Wiring Diagram</b> .....	<b>38</b>
<b>Control Board Diagnostics</b> .....	<b>15</b>	<b>Technical Data</b> .....	<b>39</b>
<b>Trigger Sensor Adjustment</b> .....	<b>16</b>	<b>Accessories</b> .....	<b>39</b>
<b>Distance Sensor Replacement</b> .....	<b>16</b>	<b>Graco Standard Warranty</b> .....	<b>40</b>
<b>Hydraulic Pump</b> .....	<b>17</b>	<b>Graco Information</b> .....	<b>40</b>

# Models







				
<b>253922</b>	✓		✓	
<b>253955</b>		✓	✓	
<b>255155</b>	✓			✓
<b>255156</b>		✓		✓

# Warnings



The following warnings are for the setup, use, grounding, maintenance, and repair of this equipment. The exclamation point symbol alerts you to a general warning and the hazard symbol refers to procedure-specific risk. Refer back to these warnings. Additional, product-specific warnings may be found throughout the body of this manual where applicable.

 <b>WARNING</b>	
	<p><b>FIRE AND EXPLOSION HAZARD</b></p> <p>Flammable fumes, such as solvent and paint fumes, in <b>work area</b> can ignite or explode. To help prevent fire and explosion:</p> <ul style="list-style-type: none"> <li>• Use equipment only in well ventilated area.</li> <li>• Do not fill fuel tank while engine is running or hot; shut off engine and let it cool. Fuel is flammable and can ignite or explode if spilled on hot surface.</li> <li>• Eliminate all ignition sources; such as pilot lights, cigarettes, portable electric lamps, and plastic drop cloths (potential static arc).</li> <li>• Keep work area free of debris, including solvent, rags and gasoline.</li> <li>• Do not plug or unplug power cords, or turn power or light switches on or off when flammable fumes are present.</li> <li>• Ground all equipment in the work area. See <b>Grounding</b> instructions.</li> <li>• Use only grounded hoses.</li> <li>• Hold gun firmly to side of grounded pail when triggering into pail.</li> <li>• If there is static sparking or you feel a shock, <b>stop operation immediately</b>. Do not use equipment until you identify and correct the problem.</li> <li>• Keep a working fire extinguisher in the work area.</li> </ul>
	<p><b>CARBON MONOXIDE HAZARD</b></p> <p>Exhaust contains poisonous carbon monoxide, which is colorless and odorless. Breathing carbon monoxide can cause death. Do not operate in an enclosed area.</p>
	<p><b>SKIN INJECTION HAZARD</b></p> <p>High-pressure fluid from gun, hose leaks, or ruptured components will pierce skin. This may look like just a cut, but it is a serious injury that can result in amputation. <b>Get immediate surgical treatment.</b></p> <ul style="list-style-type: none"> <li>• Do not point gun at anyone or at any part of the body.</li> <li>• Do not put your hand over the spray tip.</li> <li>• Do not stop or deflect leaks with your hand, body, glove, or rag.</li> <li>• Do not spray without tip guard and trigger guard installed.</li> <li>• Engage trigger lock when not spraying.</li> <li>• Follow <b>Pressure Relief Procedure</b> in this manual, when you stop spraying and before cleaning, checking, or servicing equipment.</li> </ul>
	<p><b>PRESSURIZED EQUIPMENT HAZARD</b></p> <p>Fluid from the gun/dispense valve, leaks, or ruptured components can splash in the eyes or on skin and cause serious injury.</p> <ul style="list-style-type: none"> <li>• Follow <b>Pressure Relief Procedure</b> in this manual, when you stop spraying and before cleaning, checking, or servicing equipment.</li> <li>• Tighten all fluid connections before operating the equipment.</li> <li>• Check hoses, tubes, and couplings daily. Replace worn or damaged parts immediately.</li> </ul>
	<p><b>PRESSURIZED ALUMINUM PARTS HAZARD</b></p> <p>Do not use 1,1,1-trichloroethane, methylene chloride, other halogenated hydrocarbon solvents or fluids containing such solvents in pressurized aluminum equipment. Such use can cause serious chemical reaction and equipment rupture, and result in death, serious injury, and property damage.</p>

 **WARNING**

	<p><b>EQUIPMENT MISUSE HAZARD</b></p> <p>Misuse can cause death or serious injury.</p> <ul style="list-style-type: none"> <li>• Do not operate the unit when fatigued or under the influence of drugs or alcohol.</li> <li>• Do not exceed the maximum working pressure or temperature rating of the lowest rated system component. See <b>Technical Data</b> in all equipment manuals.</li> <li>• Use fluids and solvents that are compatible with equipment wetted parts. See <b>Technical Data</b> in all equipment manuals. Read fluid and solvent manufacturer's warnings. For complete information about your material, request MSDS forms from distributor or retailer.</li> <li>• Check equipment daily. Repair or replace worn or damaged parts immediately with genuine manufacturer's replacement parts only.</li> <li>• Do not alter or modify equipment.</li> <li>• Use equipment only for its intended purpose. Call your distributor for information.</li> <li>• Route hoses and cables away from traffic areas, sharp edges, moving parts, and hot surfaces.</li> <li>• Do not kink or over bend hoses or use hoses to pull equipment.</li> <li>• Keep children and animals away from work area.</li> <li>• Comply with all applicable safety regulations.</li> </ul>
	<p><b>BURN HAZARD</b></p> <p>Equipment surfaces and fluid that's heated can become very hot during operation. To avoid severe burns, do not touch hot fluid or equipment. Wait until equipment/fluid has cooled completely.</p>
	<p><b>MOVING PARTS HAZARD</b></p> <p>Moving parts can pinch or amputate fingers and other body parts.</p> <ul style="list-style-type: none"> <li>• Keep clear of moving parts.</li> <li>• Do not operate equipment with protective guards or covers removed.</li> <li>• Pressurized equipment can start without warning. Before checking, moving, or servicing equipment, follow the <b>Pressure Relief Procedure</b> in this manual. Disconnect power or air supply.</li> </ul>
	<p><b>TOXIC FLUID OR FUMES HAZARD</b></p> <p>Toxic fluids or fumes can cause serious injury or death if splashed in the eyes or on skin, inhaled, or swallowed.</p> <ul style="list-style-type: none"> <li>• Read MSDS's to know the specific hazards of the fluids you are using.</li> <li>• Store hazardous fluid in approved containers, and dispose of it according to applicable guidelines.</li> <li>• Always wear impervious gloves when spraying or cleaning equipment.</li> </ul>
	<p><b>PERSONAL PROTECTIVE EQUIPMENT</b></p> <p>You must wear appropriate protective equipment when operating, servicing, or when in the operating area of the equipment to help protect you from serious injury, including eye injury, inhalation of toxic fumes, burns, and hearing loss. This equipment includes but is not limited to:</p> <ul style="list-style-type: none"> <li>• Protective eyewear</li> <li>• Clothing and respirator as recommended by the fluid and solvent manufacturer</li> <li>• Gloves</li> <li>• Hearing protection</li> </ul>
	<p><b>RECOIL HAZARD</b></p> <p>Gun may recoil when triggered. If you are not standing securely, you could fall and be seriously injured.</p>
	<p><b>CALIFORNIA PROPOSITION 65</b></p> <p>The engine exhaust from this product contains a chemical known to the State of California to cause cancer, birth defects or other reproductive harm.</p> <p>This product contains a chemical known to the State of California to cause cancer, birth defects or other reproductive harm. Wash hands after handling.</p>

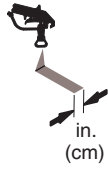
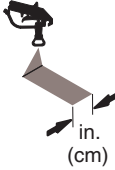
# Tip Selection

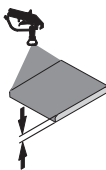
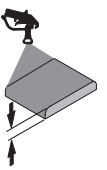
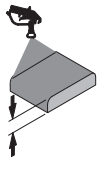
							
LL5213*	2 (5)				✓		
LL5215*	2 (5)					✓	
LL5217		4 (10)				✓	
LL5219		4 (10)					✓
LL5315		4 (10)			✓		
LL5317		4 (10)			✓		
LL5319		4 (10)				✓	
LL5321		4 (10)				✓	
LL5323		4 (10)				✓	
LL5325		4 (10)					✓
LL5327		4 (10)					✓
LL5329		4 (10)					✓
LL5331		4 (10)					✓
LL5333		4 (10)					✓
LL5335		4 (10)					✓
LL5355		4 (10)					✓
LL5417			6 (15)		✓		
LL5419			6 (15)		✓		
LL5421			6 (15)		✓		
LL5423			6 (15)			✓	
LL5425			6 (15)			✓	
LL5427			6 (15)			✓	
LL5429			6 (15)			✓	
LL5431			6 (15)				✓
LL5435			6 (15)				✓
LL5621				12 (30)	✓		
LL5623				12 (30)	✓		
LL5625				12 (30)	✓		
LL5627				12 (30)	✓		
LL5629				12 (30)	✓		
LL5631				12 (30)		✓	
LL5635				12 (30)		✓	
LL5639				12 (30)			✓

\* Use 100 mesh filter to reduce tip clogs.

# General Repair Information



1. **Keep all screws, nuts, washers, gaskets, and electrical fittings** removed during repair procedures. These parts are not normally provided with replacement assemblies.
2. **Test repair** after problem is corrected.
3. **If sprayer does not operate properly**, review repair procedure to verify procedure was done correctly. If necessary, see **Troubleshooting**, page 8, for other possible solutions.

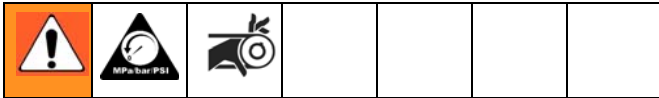

4. **Install belt guard before operation** of sprayer and replace if damaged. Belt guard reduces risk of pinching and loss of fingers.

## Grounding

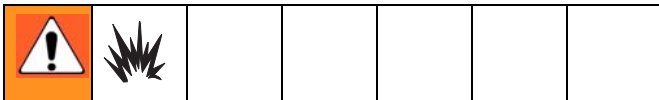

Ground sprayer with grounding clamp to earth ground when flushing sprayer. FIG. 1.

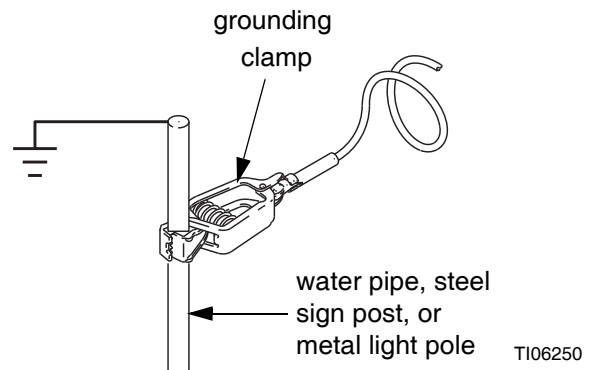
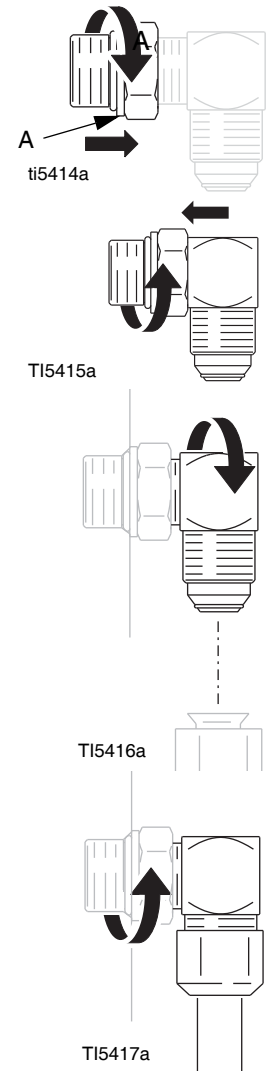

FIG. 1

## SAE O-Ring Installation

1. Unscrew lock nut to touch fitting.
2. Lubricate o-ring (A).
3. Screw in fitting hand tight.
4. Unscrew fitting until oriented properly.



5. Tighten lock nut to

# Maintenance

## Pressure Relief Procedure

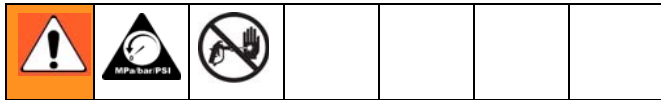

1. Engage trigger lock.
2. Turn engine ON/OFF switch to OFF.
3. Move pump valve to OFF and turn pressure control knob fully counterclockwise.
4. Disengage the trigger lock.
5. Hold a metal part of the gun firmly to a grounded metal pail. Trigger the gun to relieve pressure.
6. Engage the trigger lock.
7. Open pressure drain valve. Leave valve open until you are ready to spray again.
8. If you suspect the spray tip or hose is clogged or that pressure has not been fully relieved after following the steps above, **VERY SLOWLY** loosen tip guard retaining nut or hose end coupling to relieve pressure gradually, then loosen completely. Clear hose or tip obstruction.

### CAUTION

- Minimum hose size allowable for proper sprayer operation is 3/8 in. x 50 ft.
- For detailed engine maintenance and specifications, refer to separate Honda Engines Owner's Manual, supplied.

## Trigger Lock

Always engage the trigger lock when you stop spraying to prevent the gun from being triggered accidentally by hand or if dropped or bumped.

## Periodic Maintenance

**DAILY:** Check engine oil level and fill as necessary.

**DAILY:** Check hydraulic oil level and fill as necessary.

**DAILY:** Check hose for wear and damage.

**DAILY:** Check gun safety for proper operation.

**DAILY:** Check prime/spray drain valve for proper operation.

**DAILY:** Check and fill the gas tank.

**DAILY:** Check that displacement pump is tight.

**DAILY:** Top off TSL level in displacement pump packing nut to help prevent material buildup on piston rod and early wear of packings.

**DAILY:** Verify calibration.

**AFTER THE FIRST 20 HOURS OF OPERATION:** Drain engine oil and refill with clean oil. Reference Honda Engines Owner's Manual for correct oil viscosity.

**WEEKLY:** Remove air filter cover and clean element. Replace element, if necessary. If operating in an unusually dusty environment: check filter daily and replace, if necessary.

Replacement elements can be purchased from your local HONDA dealer.

**WEEKLY/DAILY:** Remove any debris from hydraulic rod.

**AFTER EACH 100 HOURS OF OPERATION:** Change engine oil. Reference Honda Engines Owner's Manual for correct oil viscosity.

**SEMI-ANNUALLY:** Check belt wear, page 18; replace if necessary.

**YEARLY OR 2000 HOURS:** Replace hydraulic oil and filter element with Graco hydraulic oil 169236 (5 gallon/18.9 liter) or 207428 (1 gallon/3.8 liter) and filter element 246173; page 23.

**SPARK PLUG:** Use only BPR6ES (NGK) or W20EPR-U (NIPPONDENSO) plug. Gap plug to 0.028 to 0.031 in. (0.7 to 0.8 mm). Use spark plug wrench when installing and removing plug.

## Caster Wheel

(See letter call-outs in **Parts** drawing on page 25.)

1. Once each year, tighten nut (127, detail A) until spring washer bottoms out. Then back off the nut 1/2 to 3/4 turn.
2. Once each year, tighten nut (127) until it begins to compress spring washer. Then tighten the nut an additional 1/4 turn.
3. Once each month, grease the wheel bearing (F).
4. Check pin (55) for wear. If pin is worn out, there will be play in the caster wheel. Reverse or replace the pin as needed.
5. Check caster wheel alignment as necessary. To align: loosen bolt (145), align wheel and tighten bolt.

## Troubleshooting



Problem	Cause	Solution
E=XX is displayed.	Fault condition exists.	Determine fault correction from table, page 19.
Gas engine pulls hard (won't start).	Hydraulic pressure is too high.	Turn hydraulic pressure knob counterclockwise to lowest setting.
Engine won't start.	Engine switch is OFF.	Turn engine switch ON.
	Engine is out of gas.	Refill gas tank. Honda Engines Owner's Manual.
	Engine oil level is low.	Try to start engine. Replenish oil, if necessary. Honda Engines Owner's Manual.
	Spark plug cable is disconnected or damaged.	Connect spark plug cable or replace spark plug.
	Cold engine.	Use choke.
	Fuel shutoff lever is OFF.	Move lever to ON position.
Engine operates, but displacement pump does not operate.	Oil is seeping into combustion chamber.	Remove spark plug. Pull starter 3 to 4 times. Clean or replace spark plug. Start engine. Keep sprayer upright to avoid oil seepage.
	Pump valve is OFF.	Turn pump valve ON.
	Pressure setting is too low.	Turn pressure adjusting knob clockwise to increase pressure. Manual 312190.
	Fluid filter (11) is dirty.	Clean filter.
	Tip or tip filter is clogged.	Clean tip or tip filter. Manual 311254.
	Displacement pump piston rod is stuck due to dried paint.	Repair pump. Manual 309277.
	Belt worn, broken or off pulley.	Replace.
	Hydraulic fluid too low.	Shut of sprayer. Add fluid*.
Hydraulic motor not shifting.	Set pump valve OFF. Turn pressure down. Turn engine OFF. Pry rod up or down until hydraulic motor shifts.	

\* Check hydraulic fluid level often. Do not allow it to become too low. Use only Graco approved hydraulic fluid, page 7.



<b>Problem</b>	<b>Cause</b>	<b>Solution</b>
Displacement pump operates, but output is low on upstroke	Piston ball is not seating.	Service piston ball. Manual 309277.
	Piston packings are worn or damaged.	Replace packings. Manual 309277.
Displacement pump operates but output is low on downstroke and/or on both strokes.	Strainer (34e) is clogged.	Clean strainer.
	O-ring in pump is worn or damaged.	Replace o-ring. Manual 309277.
	Intake valve ball is packed with material or is not seating properly.	Clean intake valve. Manual 309277.
	Engine speed is too low.	Increase throttle setting. Manual 312190.
	Suction tube air leak.	Tighten suction tube.
	Pressure setting is too low.	Increase pressure. Manual 312190.
	Fluid filter (11), tip filter or tip is clogged or dirty.	Clean filter. Manual 312190 or 311254.
	Large pressure drop in hose with heavy materials.	Use larger diameter hose and/or reduce overall length of hose. Use of more than 100 ft of 1/4 in. hose significantly reduces performance of sprayer. Use 3/8 in. hose for optimum performance (50 ft minimum).
Pump is difficult to prime.	Air in pump or hose.	Check and tighten all fluid connections.  Reduce engine speed and cycle pump as slowly as possible during priming.
	Intake valve is leaking.	Clean intake valve. Be sure ball seat is not nicked or worn and that ball seats well. Reassemble valve.
	Pump packings are worn.	Replace pump packings. Manual 309277.
	Paint is too thick.	Thin the paint according to the supplier's recommendations.
	Engine speed is too high.	Decrease throttle setting before priming pump. Manual 312190.
High engine speed at no load.	Misadjusted throttle setting.	Reset throttle to 3700-3800 engine rpm at no load.
	Worn engine governor.	Replace or service engine governor.
Low stall or run pressure shown on display.	New pump or new packings.	Pump break-in period takes up to 100 gallons of material.
	Faulty transducer.	Replace transducer.
Excessive paint leakage into throat packing nut.	Throat packing nut is loose.	Remove throat packing nut spacer. Tighten throat packing nut just enough to stop leakage.
	Throat packings are worn or damaged.	Replace packings. Manual 309277.
	Displacement rod is worn or damaged.	Replace rod. Manual 309277.
Fluid is spitting from gun.	Air in pump or hose.	Check and tighten all fluid connections. Reprime pump. Manual 312190.
	Tip is partially clogged.	Clear tip. Manual 311254.
	Fluid supply is low or empty.	Refill fluid supply. Prime pump. Manual 312190. Check fluid supply often to prevent running pump dry.

<b>Problem</b>	<b>Cause</b>	<b>Solution</b>
Excessive leakage around hydraulic motor piston rod wiper.	Piston rod seal worn or damaged.	Replace these parts.
Fluid delivery is low.	Pressure setting too low.	Increase pressure. Manual 312190.
	Displacement pump outlet filter (if used) is dirty or clogged.	Clean filter.
	Intake line to pump inlet is not tight.	Tighten.
	Hydraulic motor is worn or damaged.	Bring sprayer to Graco distributor for repair.
	Large pressure drop in fluid hose.	Use larger diameter or shorter hose.
The sprayer overheats.	Paint buildup on hydraulic components.	Clean.
	Oil level is low.	Fill with oil, page 7.
Excessive hydraulic pump noise.	Low hydraulic fluid level.	Shut off sprayer. Add fluid*, page 7.
Gallon counter not working.	Broken or disconnected wire.	Check wires and connections. Replace broken wires.
	Bad sensor.	Replace sensor.
	Missing or damaged magnet.	Reposition or replace magnet.
Sprayer operates, but display does not.	Bad connection between control board and display.	Remove display and reconnect.
	Display damaged.	Replace display.
	Loose cables.	Connect cables to back of control board.
	Control board LED not flashing.	Replace control board.
Distance counter not operating properly.	Trigger sensor not set correctly.	See "Spray icon does not show on display when fluid is sprayed".
	Bad wiring connections.	Check connector, and reconnect.
	Distance sensor not spaced correctly from gear.	Adjust space between sensor and gear to .050 +/- .020 in. See page 16.
	Distance sensor and gear not aligned.	Remove tire, and press in or pull out gear to align sensor and gear.
	Gear teeth missing or damaged.	Replace distance gear/wheel.
	Wire cracked or broken.	Replace sensor.
Mils not calculating.	Distance sensor.	See "Distance counter not operating properly".
	Trigger sensor.	See "Spray icon does not show on display when fluid is sprayed".
	Gallon counter.	See "Gallon counter not working".
	Bad or damaged control board.	Replace control board.
Fluid spray starts after spray icon is shown on display.	Interrupter (164) is improperly positioned.	Turn screw counterclockwise until spray icon synchronizes with fluid spray.
Fluid spray starts before spray icon is shown on display.	Interrupter (164) is improperly positioned.	Turn screw clockwise until spray icon is synchronized with fluid spray.

Problem	Cause	Solution
Spray icon does not show on display when fluid is sprayed.	Loose connector.	Check that 5-pin connector and reed switch are properly connected.
	Interrupter (164) is improperly positioned.	Turn screw counterclockwise until spray icon synchronizes with fluid spray.
	Reed switch assembly (18) is damaged.	Replace reed switch assembly (18).
	Magnet on assembly (18) is missing.	Replace reed switch assembly (18).
	A connector on wiring harness or on reed switch (18) is damaged.	<p>Disconnect reed switch and 5-pin connector from back of control board.</p> <p>Check continuity between pin 1 on 2-pin connector and pin 1 on 5-pin connector. Check continuity between pin 2 on 2-pin connector and pin 4 on 5-pin connector. If there is no continuity in either case, replace wiring harness.</p> <p>If there is continuity in both cases replace reed switch assembly (18).</p>
	Cut or sliced wire.	Replace wiring harness.
	Control board is damaged.	Replace control board.
Display is damaged.		Replace display.
Spray icon is always shown on display.	Interrupter (164) is improperly positioned.	Turn screw clockwise until spray icon is synchronized with fluid spray.
	Reed switch assembly (18) is damaged.	Replace reed switch assembly (18).
Pressure control knob does not rotate.	Knob is jammed.	Pull back cover where remote cable connects to hydraulic pump and turn counter clockwise (ccw) until free.
Pressure control knob rotates freely with no pressure change.	Remote cable broken or disconnected.	Replace or reconnect cable.
Engine bounces when striping.	Spring is broken, loose or missing.	Replace or reconnect spring.
No dots or poor dots with ghosting	No dots.	Check that solenoid power cord is plugged in.
		Check Remote button. Verify Remote button operation by changing angle in <b>ANGLE CALC</b> display.
		Solenoid cartridge bar is too far away from aerosol marking can spray tip. Do <b>Auto-Layout Can Actuator Adjustment</b> .
	Poor dots or dots with ghosting.	Solenoid cartridge bar is too close to aerosol marking can spray tip. Do <b>Auto-Layout Can Actuator Adjustment</b> .
	Engine speed too slow	Engine speed must be greater than 2600 rpm.
	Aerosol can malfunctioning	Check that can sprays. Replace if not.
	Solenoid module malfunctioning	Replace solenoid module.

# Auto-Layout Can Actuator Adjustment

## Adjustments

The can actuator is set at the factory. If the dot size is not as desired, do the coarse and/or fine adjustments.

### Coarse Adjustment

- 1 Locate four screws on side of holder base.

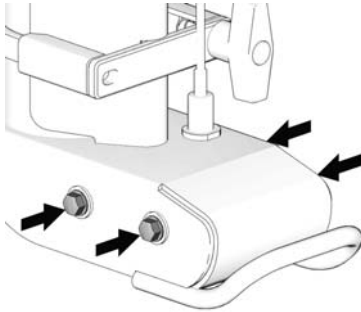

ti10070a

- 2 Loosen screws to allow holder base to move freely.

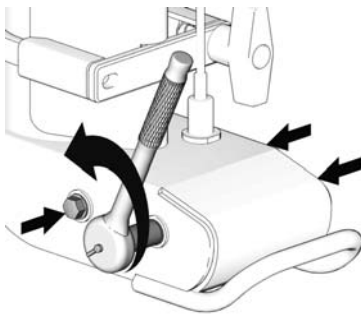

ti10071a



Do not aim aerosol can at your face.

- 3 Move holder base until solenoid cartridge bar is approximately 0.10 in. (thickness of two dimes) from spray tip.

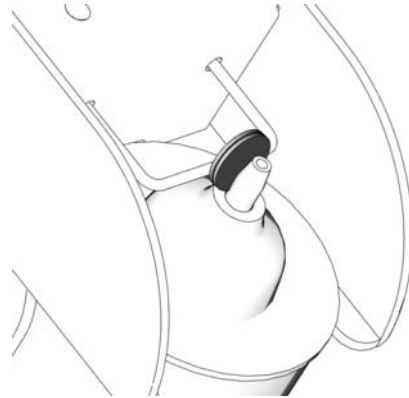

ti10072a

- 4 Carefully tighten screws. Verify gap.

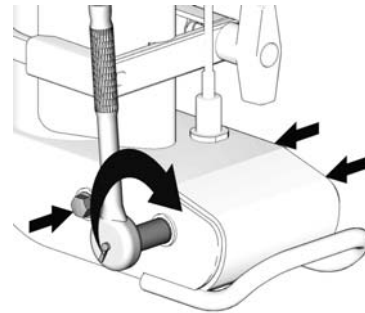

ti10073a

### Fine Adjustment

If coarse adjustment did not achieve desired dot size, proceed as follows:

- 1 Start striper and move to **PARKING MODE** display.

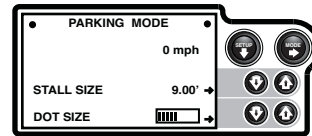

ti9919a

- 2 Set **DOT SIZE** setting to smallest size (least amount of bars on display). Press arrow keys to increase/decrease size.
- 3 Do **Coarse Adjustment** steps 1 and 2. Move holder base until a dot size of approximately a dime is achieved. Tighten screws on holder base.

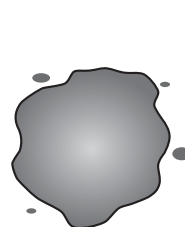

Good Dot

ti10379a



Poor Dot with Ghosting

ti10380a  
312226P

# Auto-Layout System

## Engine Stop Switch

### Removal



1. Relieve pressure, page 7.
2. FIG. 2. Remove two screws (103) and cover (31).
3. Remove two spade connectors from ENGINE STOP switch (15f).
4. Press in on two retaining tabs on each side of ENGINE STOP switch and remove switch.

### Installation

1. FIG. 2. Install ENGINE STOP switch (15f) so tabs of switch snap into place on inside of pressure control housing.
2. Connect two spade connectors to ENGINE STOP switch (15f).
3. Install cover (31) with two screws (103).

## Control Board

### Removal

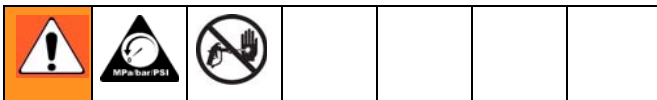

1. Relieve pressure, page 7.
2. FIG. 2. Remove two screws (103) and cover (31).
3. Pull display connector wings (A) open on control board and pull display connector out.

4. Note on paper, lead connections to the control board. Disconnect leads from control board (15d).

5. Remove six screws (15k) from control board.

### Installation

1. FIG. 2. Install control board (15d) and six screws (15k). Torque to 105-115 in-lb.
2. Connect leads to control board. (Refer to note on lead connections.)
3. Push display connector into control board close display connector wings (A) on control board.
4. Install cover (31) with two screws (103).

## Pressure Control Transducer

### Removal

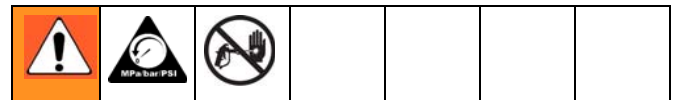

1. Relieve pressure, page 7.
2. FIG. 2. Remove two screws (103) and cover (31).
3. Disconnect transducer lead (C) from control board (15d).
4. Remove pressure control transducer (259) and o-ring (124) from filter housing.

### Installation

1. FIG. 2. Install o-ring (124) and pressure control transducer (259) in filter housing. Torque to 35-45 ft-lb.
2. Connect transducer lead (C) to motor control board (15d).
3. Install cover (31) with two screws (103).

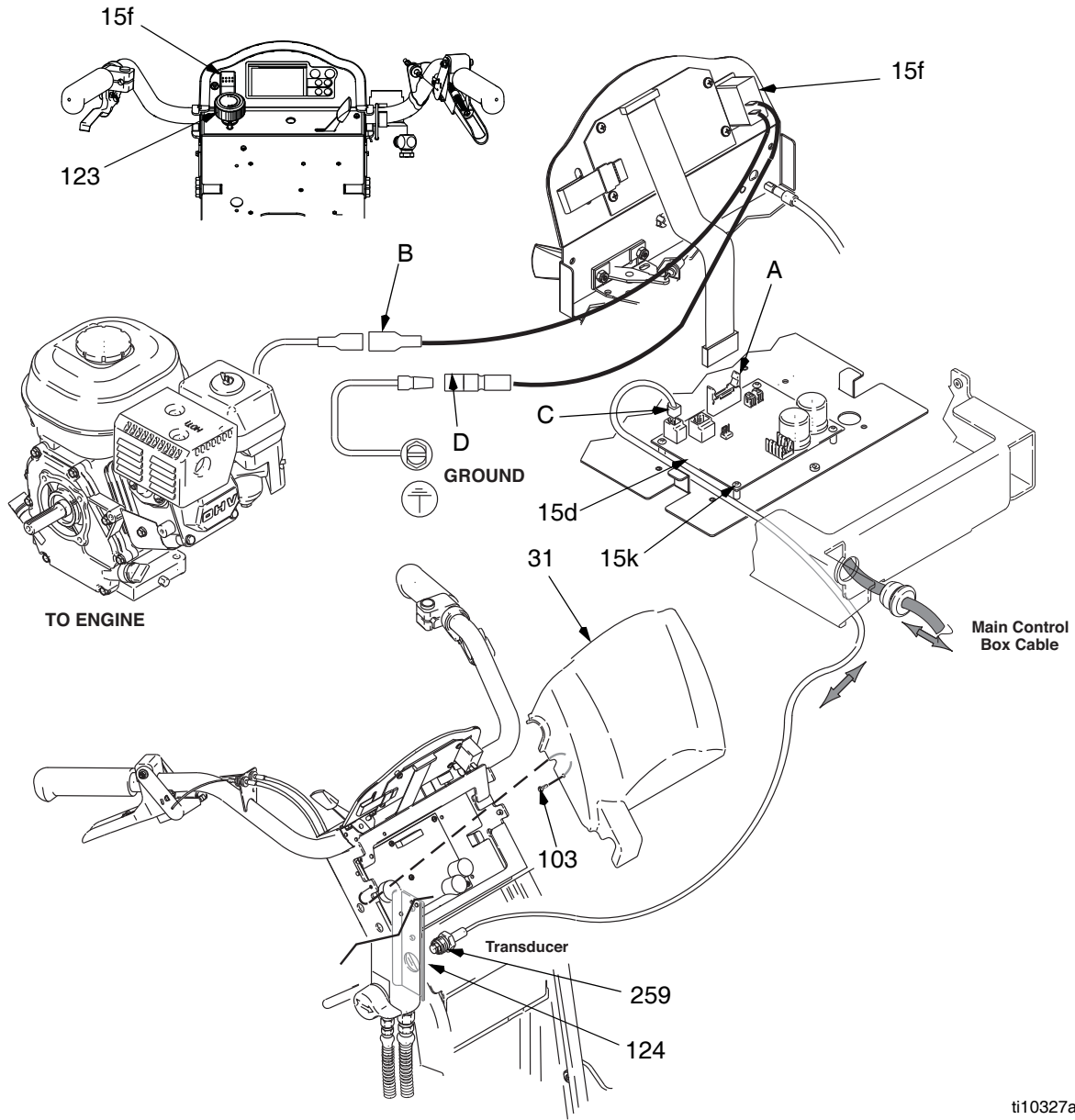

ti10327a



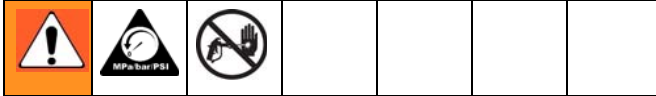

FIG. 2

# Control Board Diagnostics

## Display Messages



Relieve pressure before repair; page 7. No display does not mean that sprayer is not pressurized.

Display	Sprayer Operation	Indication	Action
No Display	Sprayer may be pressurized.	Loss of power or display not connected.	Check power source. Relieve pressure before repair or disassembly. Verify display is connected.
 ti6314a	Sprayer may be pressurized.	Pressure less than 200 psi (14 bar, 1.4 MPa).	Increase pressure as needed.
 ti6315a	Sprayer is pressurized. Power is applied. (Pressure varies with tip size and pressure control setting.)	Normal operation.	Spray.
 ti6316a	Engine and system continue to run.	Exceeded pressure limit.	Remove any filter clogs or flow obstructions.
 ti6317a	Engine and system continue to run.	Pressure transducer faulty, bad connection or broken wire.	Check transducer connections and wire. Replace transducer or control board, if necessary.

### After a fault, follow these steps to restart sprayer:

1. Correct fault condition.
2. Turn sprayer OFF.
3. Turn sprayer ON.

## Trigger Sensor Adjustment

Refer to **Troubleshooting** for trigger sensor adjustment, and see Operation Manual 312190.

## Distance Sensor Replacement

1. Remove wheel (120) from LineLazer.
2. Remove screw (273), wire clamp (115), spacer (272) and distance sensor (66).
3. Install new distance sensor (66) and spacer (272) with wire clamp (115) and screw (273).
4. Install wheel (120) on LineLazer.

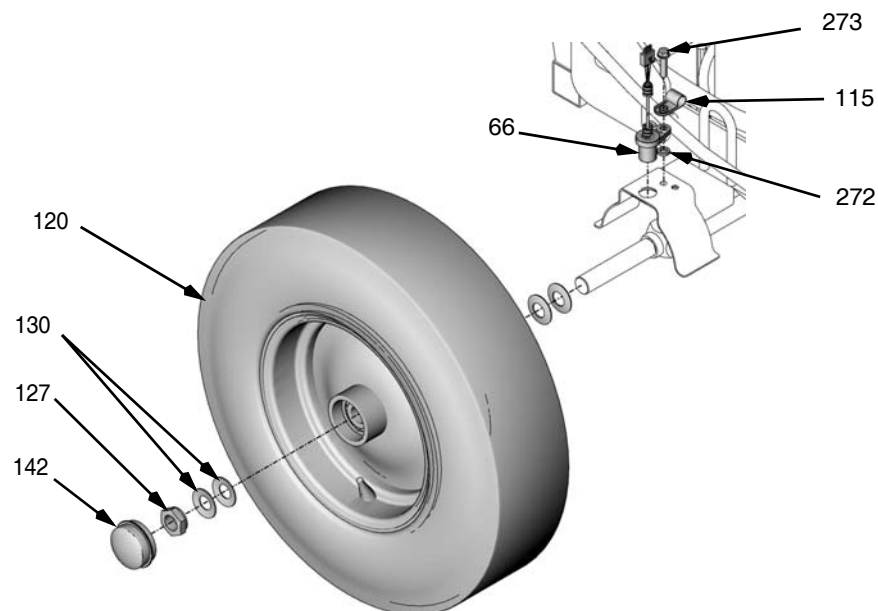

T110237a

FIG. 3



# Hydraulic Pump

## Removal



1. Allow hydraulic system to cool before beginning service.
2. Relieve pressure, page 7.
3. Place drip pan or rags under sprayer to catch hydraulic oil that leaks out during repair.
4. Fig. 4. Remove drain plug (195) and oil filter (199) and allow hydraulic oil to drain.
5. Remove screw (224), loosen belt guard knob (241) and belt guard (24).
6. Raise motor and remove belt (143).
7. Remove two set screws (169) and fan pulley (86).
8. Remove case drain tube (251).
9. Remove elbow (182).
10. Loosen screw (260) and remove pressure control guard (63).
11. Loosen set screw (102) and remove remote pressure control cable (12).
12. Remove eight screws (184), reservoir cover (237), filter assembly (A) and gasket (85).
13. Remove four screws (215) and o-rings (178), o-ring (180) and hydraulic pump (252) from reservoir cover (237).

## Installation

1. Install hydraulic pump (252) on reservoir cover (237) with four screws (215) and o-rings (178), o-ring (180); torque 100 in-lb (11 N•m).
2. Install gasket (85) filter assembly (A) and reservoir cover (237) with eight screws (184); torque 90 in-lb (10 N•m).
3. Install elbow (182) per instructions, page 6; torque to 15 ft-lb (20.3 N•m).
4. Install pressure control guard (63) and tighten screw (260).
5. Connect hydraulic hoses (32) and (35).
6. Install case drain tube (251); torque to 15 ft-lb (20.3 N•m).
7. Install fan pulley (86) with two set screws (169).
8. Raise motor and install belt (143).
9. Install belt guard (24) with screw (224) and belt guard knob (241).
10. Install remote pressure control cable (12). Tighten set screw (102).
11. Install drain plug (195); torque to 110 in-lb (12.4 N•m). Install oil filter (199); tighten 3/4 turn after gasket contacts base. Fill with Graco hydraulic oil, page 7.
12. Start up and allow pump to operate at low pressure for approximately 5 minutes to purge all air.
13. Check and top off hydraulic oil level.

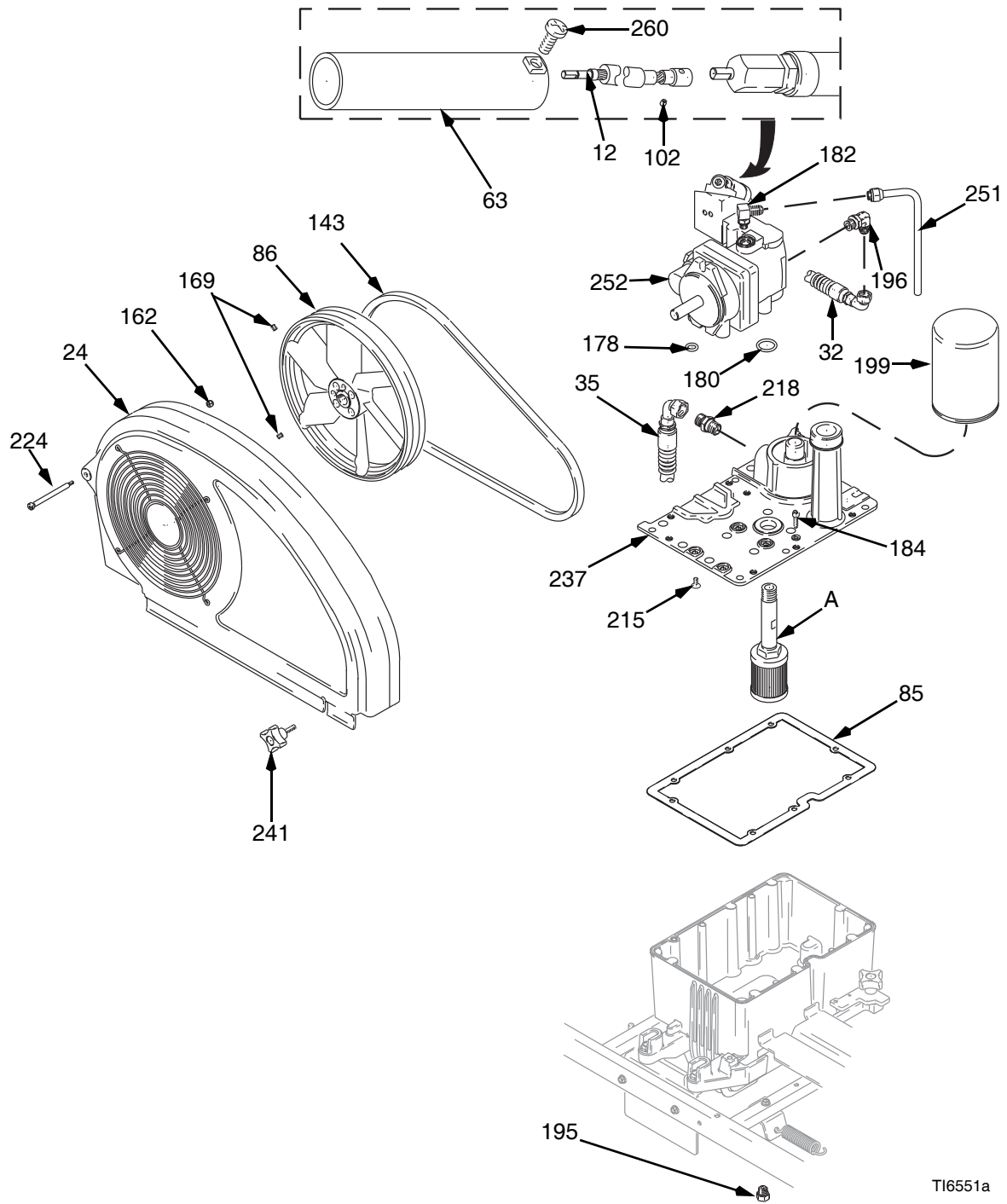

T16551a

FIG. 4

# Fan Belt

## Removal

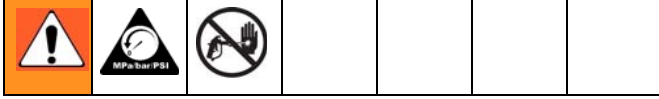

1. Relieve pressure, page 7.
2. FIG. 5. Loosen belt guard knob (241).
3. Rotate belt guard (24) up.
4. Lift engine (185) up to remove tension on belt (143).
5. Remove belt from fan pulley (86) and fan pulley (87a).

## Installation

1. Thread belt (143) around fan pulley (87a) and fan pulley (86).
2. Lower engine (185) to put tension on belt.
3. Rotate belt guard (24) down.
4. Tighten belt guard knob (241).

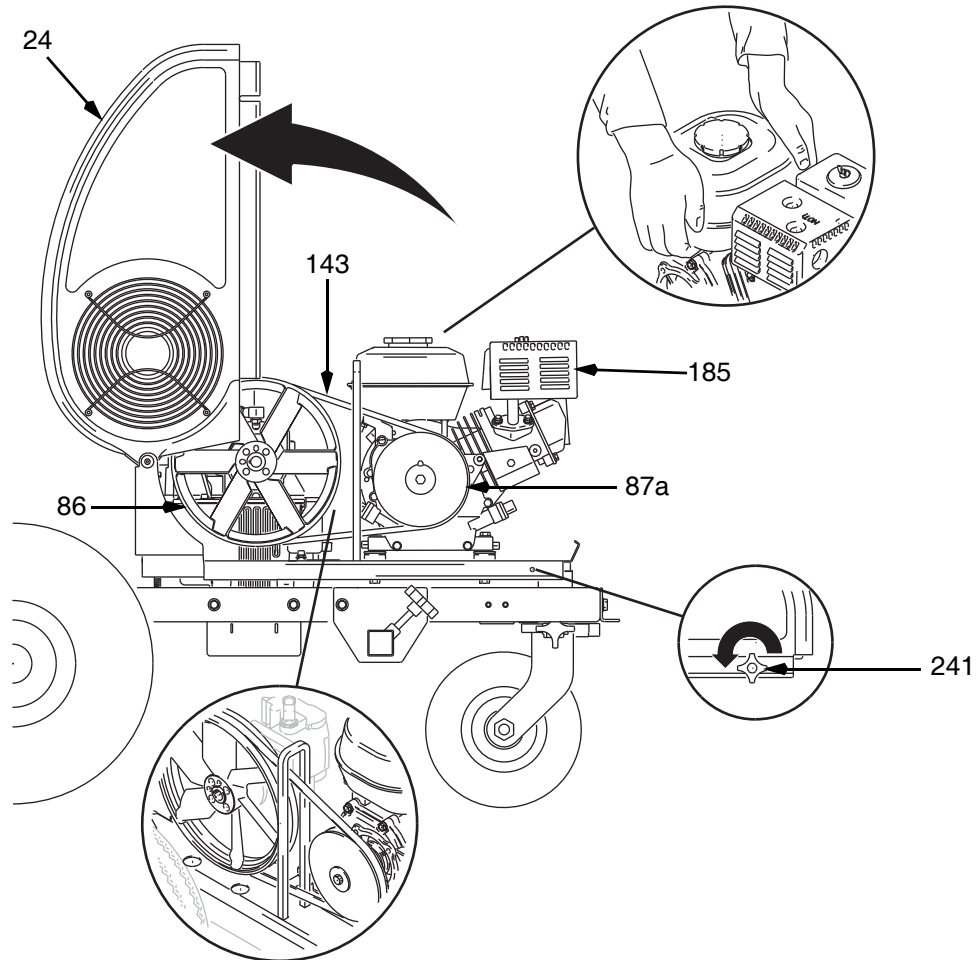

T16511a

FIG. 5

# Engine

## Removal

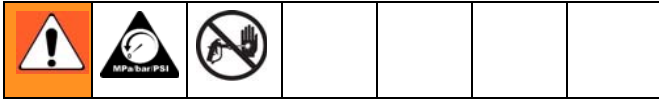

1. Relieve pressure, page 7.
2. Remove throttle cable from engine.
3. Do **Fan Belt, Removal**; page 19.
4. Loosen hand nut (241). Swing bracket (30) out.
5. FIG. 6. Disconnect red, yellow and white/red leads from engine.
6. Remove engine and rocker plate (87c) from sprayer.

7. Remove four screws (189), washers (114), washers (170) and nuts (118) and remove rocker plate, dampeners (59) and washers (114) from engine.

 All service to the engine must be performed by an authorized HONDA dealer.

## Installation

1. Install rocker plate (87c), dampeners (59) and washers (170), washers (114) on engine (185) with four screws (189), washers (170) and nuts (118); torque to 20 ft-lb (27.1 N•m).
2. Install engine and rocker plate (87c) on sprayer.
3. Connect white/red, yellow and red leads.
4. Do **Fan Belt, Installation**; page 19.
5. Swing motor retainer bracket (30) in. Tighten hand nut (241).

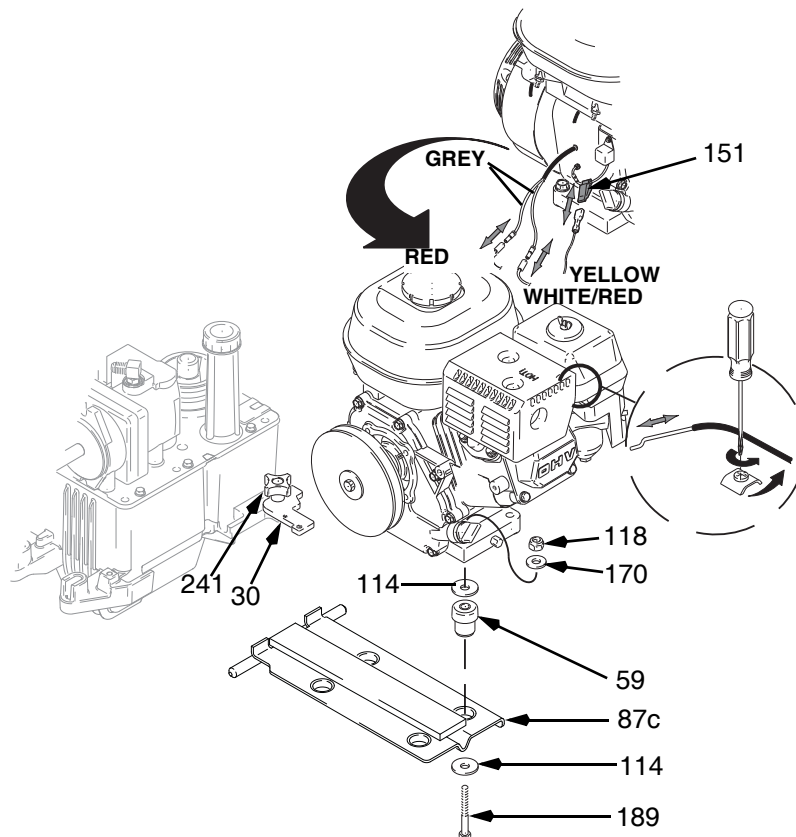

T16520b

FIG. 6

# Hydraulic Motor Rebuild

## Removal

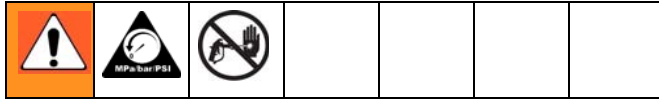

1. Relieve pressure, page 7.
2. Place drip pan or rags under sprayer to catch hydraulic oil that leaks out during repair.
3. Remove pump, page 24.
4. FIG. 7. Remove hydraulic lines (35, 250) from fittings (217) at top left and right side of hydraulic motor.
5. Loosen jam nut (183).
6. Unscrew and remove hydraulic motor cap (25).
7. Slide piston rod/hydraulic motor cap assembly (A) from hydraulic motor cylinder (69).

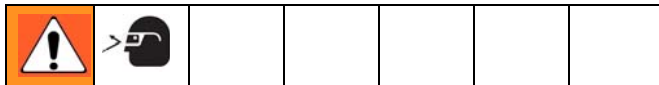

### FLYING PARTS HAZARD

Detent spring has high energy potential. If detent spring is released without due care detent spring and balls could fly into the eyes of the disassembler. Wear safety glasses when removing or installing detent spring and balls. Failure to wear safety glasses when removing detent spring could result in eye injury or blindness.

## Installation

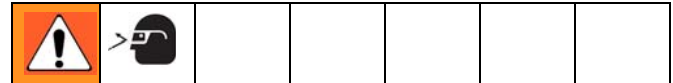

### FLYING PARTS HAZARD

1. Slide piston rod assembly (A) into hydraulic motor cylinder (69).
2. Screw down hydraulic motor cap (25) until cap bottoms out. Unscrew hydraulic motor cap until inlet and outlet align with hydraulic line fittings and test hole in hydraulic motor cap points away from belt guard (24).
3. Torque jam nut (183) against hydraulic motor cap (25) to 150 ft-lb (17 N•m).
4. Install hydraulic lines (35, 250) to fittings (217) to top left and right side of hydraulic motor per procedure on page 6; torque to 40 ft-lb (54.2 N•m).
5. Install pump, page 24.
6. Start engine and operate pump for 30 seconds. Turn engine OFF. Check hydraulic oil level and fill with Graco hydraulic oil, page 7.

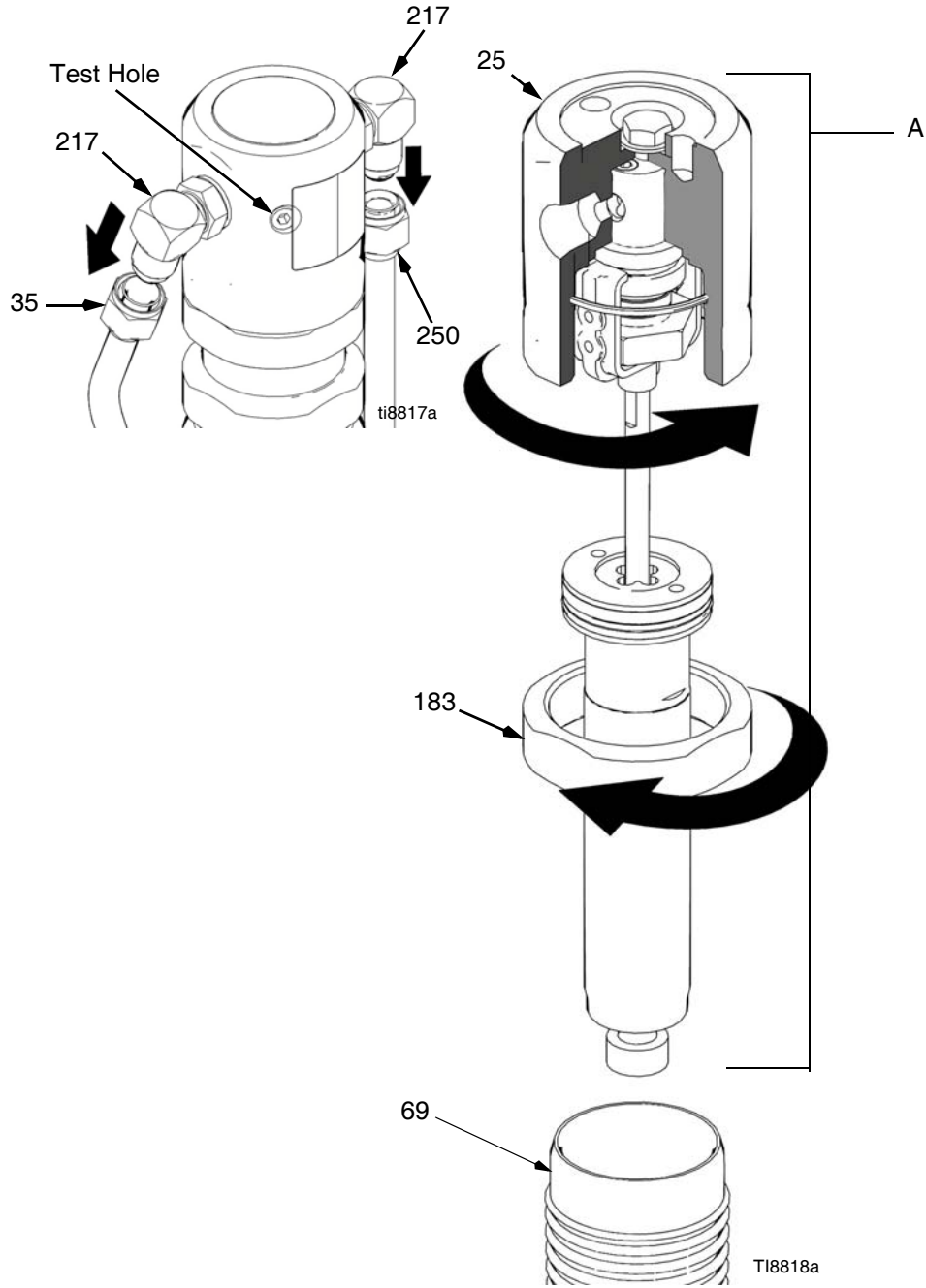

FIG. 7

# Oil/Filter Change

## Removal

1. Place drip pan or rags under sprayer to catch hydraulic oil that drains out.
2. FIG. 4. Remove drain plug (195). Allow hydraulic oil to drain.
3. FIG. 8. Unscrew filter (199) slowly - oil runs into groove and drains out rear.

## Installation

1. Install drain plug (195). Apply a light coat of oil to oil filter gasket and install oil filter (199). Tighten oil filter 3/4 turn after gasket contacts base.
2. Fill with 1.25 gallons (4.73 liters) of Graco hydraulic oil 169236 (5 gallon/20 liter) or 207428 (1 gallon/3.8 liter)

3. Check oil level.

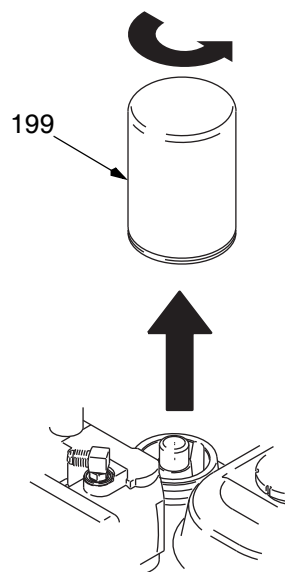

ti2271a

FIG. 8

# Gallon Counter Removal

1. Remove two screws (103) and cover (31).
2. FIG. 9. Disconnect gallon counter cable from in-line connector (A) to J12 on control board.
3. Remove guard (137) and reed switch (166) from hydraulic motor.

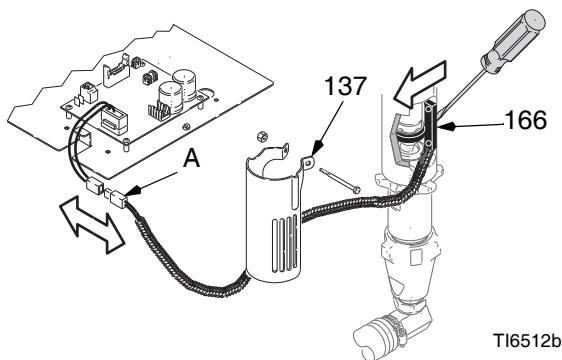

TI6512b

FIG. 9

4. FIG. 11 - FIG. 13. Remove pump.
5. FIG. 10. Remove ring magnet (222).

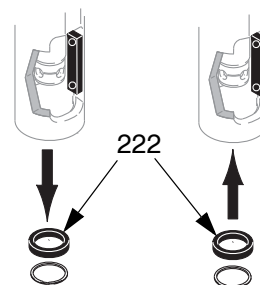

TI6513a

FIG. 10

## Installation

1. FIG. 10. Install new ring magnet (222) with dimple marks facing down.
2. FIG. 14 - FIG. 16. Install pump.
3. Install new reed switch (166) and guard (137) on hydraulic motor.
4. FIG. 9. Connect gallon counter cable to in-line connector (A) to J12 on control board.
5. Install cover (31) with two screws (103).

# Displacement Pump

See manual 309277 for pump repair instructions.

## Removal

1. Flush pump.

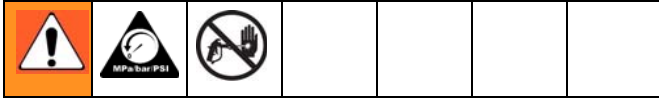

2. Relieve pressure, page 7.
3. FIG. 11. Remove suction tube (34) and hose (26).

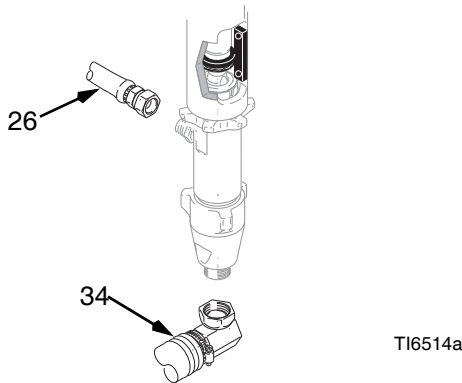

FIG. 11

### CAUTION

Gallon counter may error if magnet ring and/or sensor assembly are damaged during disassembly/assembly.

4. FIG. 12. Push magnet ring (222) up. Push retaining spring (194) up. Push out pin (249).

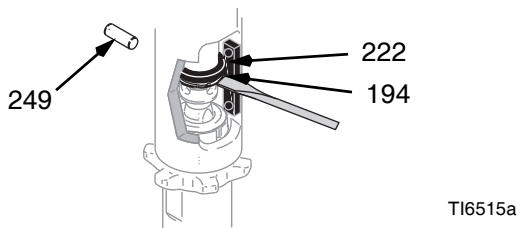
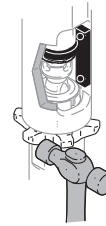

FIG. 12

5. FIG. 13. Loosen jam nut. Unscrew pump.



TI6516a

FIG. 13

## Installation

### CAUTION

If the pump jam nut loosens during operation, the threads of the hydraulic motor manifold will be damaged. Tighten jam nut as specified.

1. FIG. 14. Screw jam nut to bottom of pump threads. Screw pump completely into manifold. Unscrew pump from manifold until pump outlet aligns with hose. Hand tighten jam nut, then tap 1/8 to 1/4 turn with hammer or torque to 200 ft-lb (270 N•m).

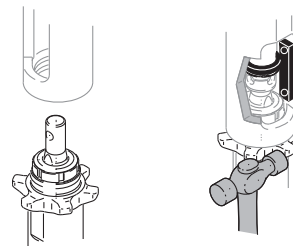

TI6517a

FIG. 14

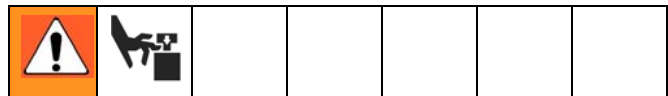

2. FIG. 15. Slowly pull engine starter rope until pump rod pin hole is aligned with hydraulic rod hole. FIG. 12. Push pin (249) into hole. Push magnet ring (222) down. Push retaining spring (194) into groove.

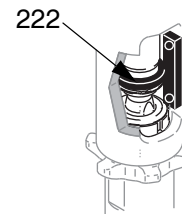

TI6518a

FIG. 15

3. FIG. 16. Fill packing nut with Graco TSL.

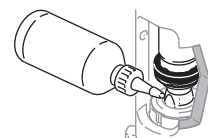

312226P



# Parts

## LineLazer IV 200HS

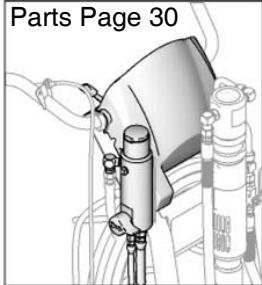

Parts Page 32

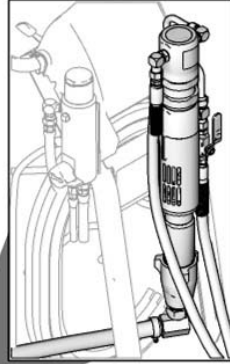

Parts Page 34

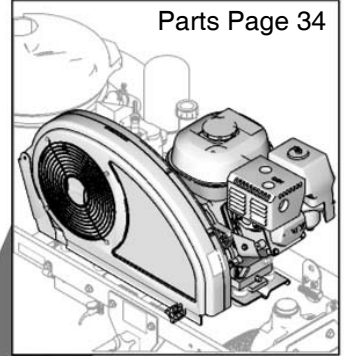

Parts Page 28

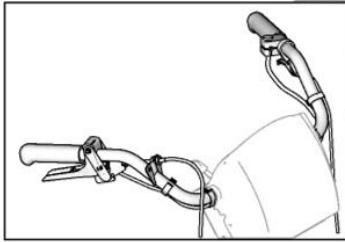

Parts Page 36

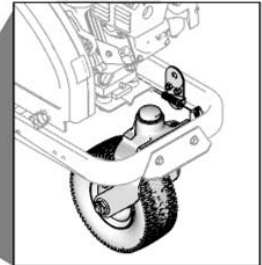

Parts Page 26

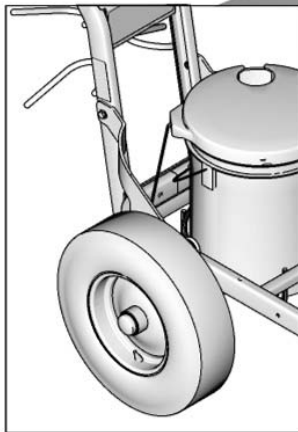

Parts Page 29

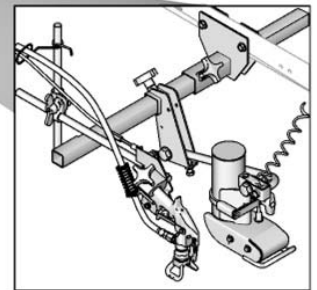

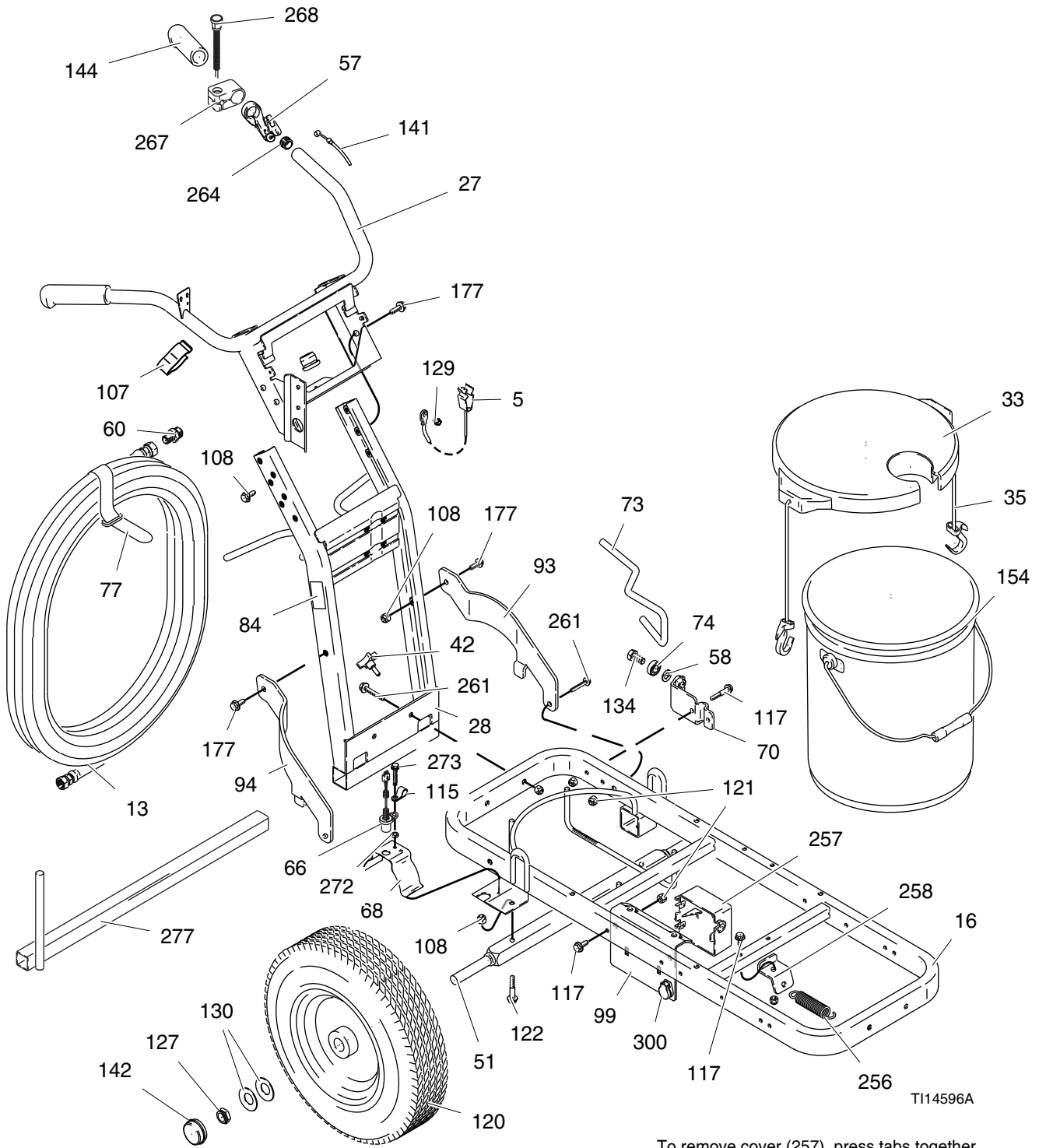

T114596A

To remove cover (257), press tabs together and pull cover away from plate (99).

## LineLazer IV 200HS

Ref	Part	Description	Qty	Ref	Part	Description	Qty
5	237686	CLAMP, grounding assy	1	115	108868	CLAMP, wire	3
13	245225	HOSE, 3/8 in. x 50 ft	1	117	110837	SCREW, flange, hex	10
16	287623	FRAME, linestriper (painted)	1	120	255162	WHEEL, pneumatic	2
27	287417	HANDLE	1	121	111040	NUT, lock, insert, nylock, 5/16	10
28	287622	SUPPORT, handle, painted	1	122	111194	SCREW, cap flange hd	2
33	287590	COVER, pail, includes 35	1	127	112405	NUT, lock	4
35	119771	STRAP, cover	2	129	112798	SCREW, thread forming, hex hd	2
42	108471	KNOB	1	130	119563	WASHER, belleville	
51	193405	AXLE	1	134	113961	SCREW, cap, hex hd	1
57	194310	LEVER, actuator	1	141	241445	CABLE, caster	1
58	195134	SPACER, ball guide	1	142	114648	CAP, dust	3
60	196176	ADAPTER, nipple	1	144	114659	GRIP, handle	2
66	15K357	SENSOR, distance	1	154	115077	PAIL, plastic	1
68	15J088	SHIELD, sensor, distance	1	177	112395	SCREW, cap, flng hd	2
70	198891	BRACKET, mounting	1	256	119696	SPRING, extension	1
73	198930	ROD, brake	1	257	287695	BOX, electric, includes 109	1
74	198931	BEARING	1	258	15F441	BRACKET, frame	1
77	114271	STRAP, retaining	1	261	116780	SCREW, hex hd	4
84▲	15F638	LABEL, warning, fire and skin	1	264	120151	PLUG, tube	2
93	15F577	BRACE, left, painted	1	267	15K162	BLOCK	1
94	15F576	BRACE, right, painted	1	268	15K283	SWITCH, push button	1
99	15F425	BRACKET, reservoir	1	272	15K452	SPACER, round, .500 O.D.	1
107	178342	CLIP, spring	4	273	260212	SCREW, hex washer head	1
108	101566	NUT, lock	2	277	15M133	CALIBRATION BAR	1
109	102478	STRAP, wiring tie (not shown)	6	300	120761	COVER, jack	1

▲ Replacement Warning Labels available at no cost.

# LineLazer IV 200Hs

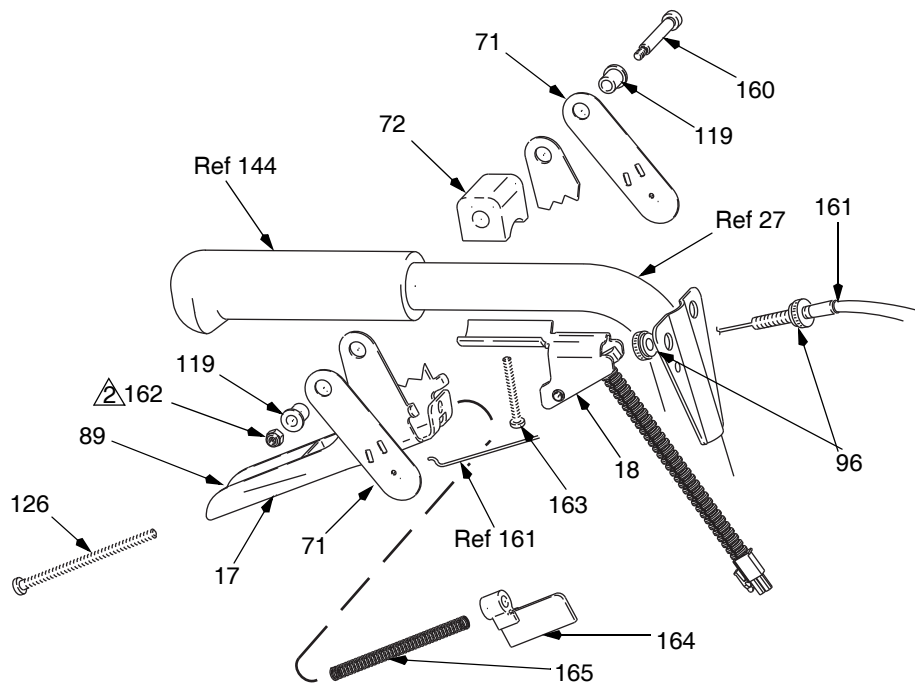
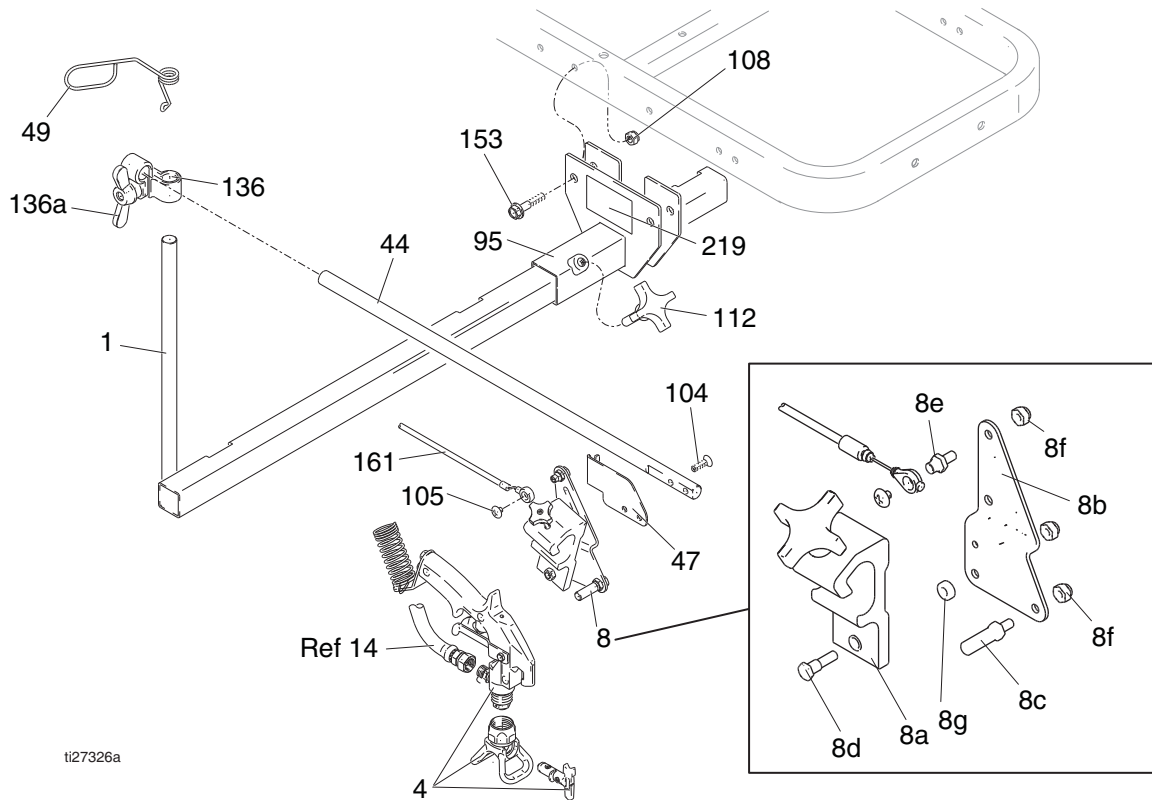

1 Torque to 90-110 in-lb.

2 Torque to 10-20 in-lb.

# LineLazer IV 200HS

Ref	Part	Description	Qty	Ref	Part	Description	Qty
1	224052	BRACKET, support gun	1	96	15F624	NUT, cable, gun	2
4	248157	GUN, flex, basic, includes guard & tip	1	104	119647	SCREW, cap, socket, flthd	2
8	287570	KIT, holder, gun	1	105	119648	SCREW, mach tursshhd, cross recess	1
8a	287569	HOLDER, gun	1	108	101566	NUT, lock	2
8b	15F214	LEVER, actuator	1	112	111145	KNOB	1
8c	15F209	STUD, pull, trigger	1	119	111017	BEARING, flange	2
8d	24Y991	KIT, pivot	1	126	112381	SCREW, mach, pan hd	1
8e	15F211	STUD, cable	1	136	287566	KIT, clamp, includes 136a	1
8f	102040	NUT, lock	4	136a	114028	NUT, wing	1
8g	24Y991	KIT, pivot	1	153	114982	SCREW, cap, flange hd	2
14	245798	HOSE, 1/4 x 7 ft	11	160	116941	SCREW, shoulder, socket head	1
17	245733	KIT, trigger handle repair, includes 89, 126, 164, 165	1	161	287696	CABLE, includes 96	1
18	287699	KIT, sensor	1	162	116969	NUT, lock	2
44	15F212	ARM, support	1	163	116973	SCREW, #10 taptite phil	1
46	111145	KNOB, pronged	1	164	117268	BRACKET, interrupter	1
47	15F213	BRACKET, cable	1	165	117269	SPRING	1
49	188135	GUIDE, cable	1	219▲	15F637	LABEL, warning	1
71	198895	PLATE, lever, pivot	2	▲ Replacement Warning Labels available at no cost.			
72	198896	BLOCK, mounting (mach)	1				
89▲	15A644	LABEL, trigger	1				
95	15K198	BRACKET, gun arm	1				

# Paint Can Holder Assembly 255346

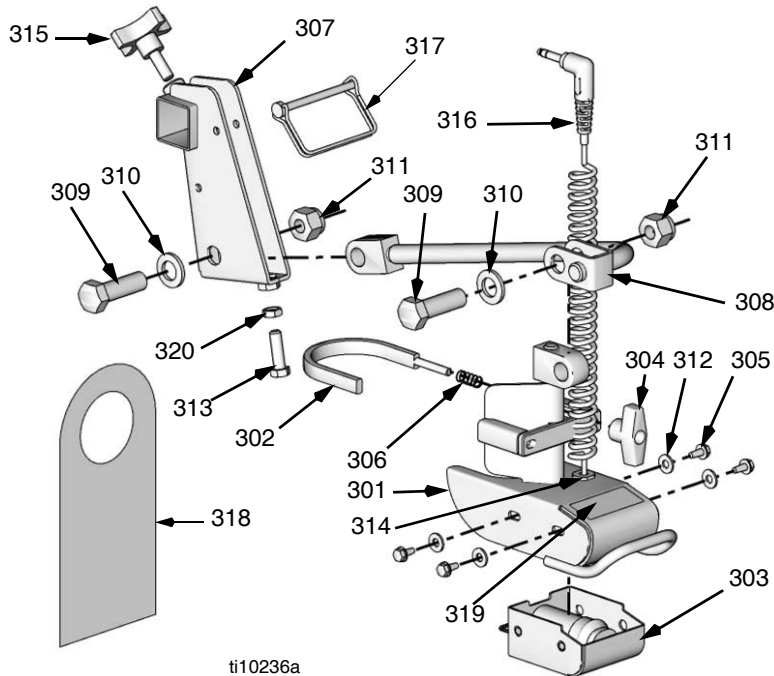

ti10236a

Ref	Part	Description	Qty	Ref	Part	Description	Qty
301	15K757	HOLDER, paint can, base (painted)	1	314	120879	BUSHING, strain relief	1
302	15K570	CLAMP, paint can	1	315	111145	KNOB, pronged	1
303	255347	CARTRIDGE, solenoid	1	316	15K103	CORD, power, solenoid	1
304	120865	KNOB, T-handle	1	317	113696	PIN, ball coupler	1
305	101501	SCREW, mach., slot hex wash hd	4	318	15M216	TAG, chalk can	1
306	120864	SPRING, compression	1	319	15M220	LABEL, Auto Layout System	1
307	15K567	CLAMP	1	320	260188	NUT, jam	1
308	15K568	ARM, pivot	1				
309	100428	SCREW, cap hex hd	2				
310	120856	WASHER, Belleville	2				
311	101712	NUT, lock	2				
312	110755	WASHER, plain	4				
313	100004	SCREW, cap, hex hd	1				

# LineLazer IV 200Hs

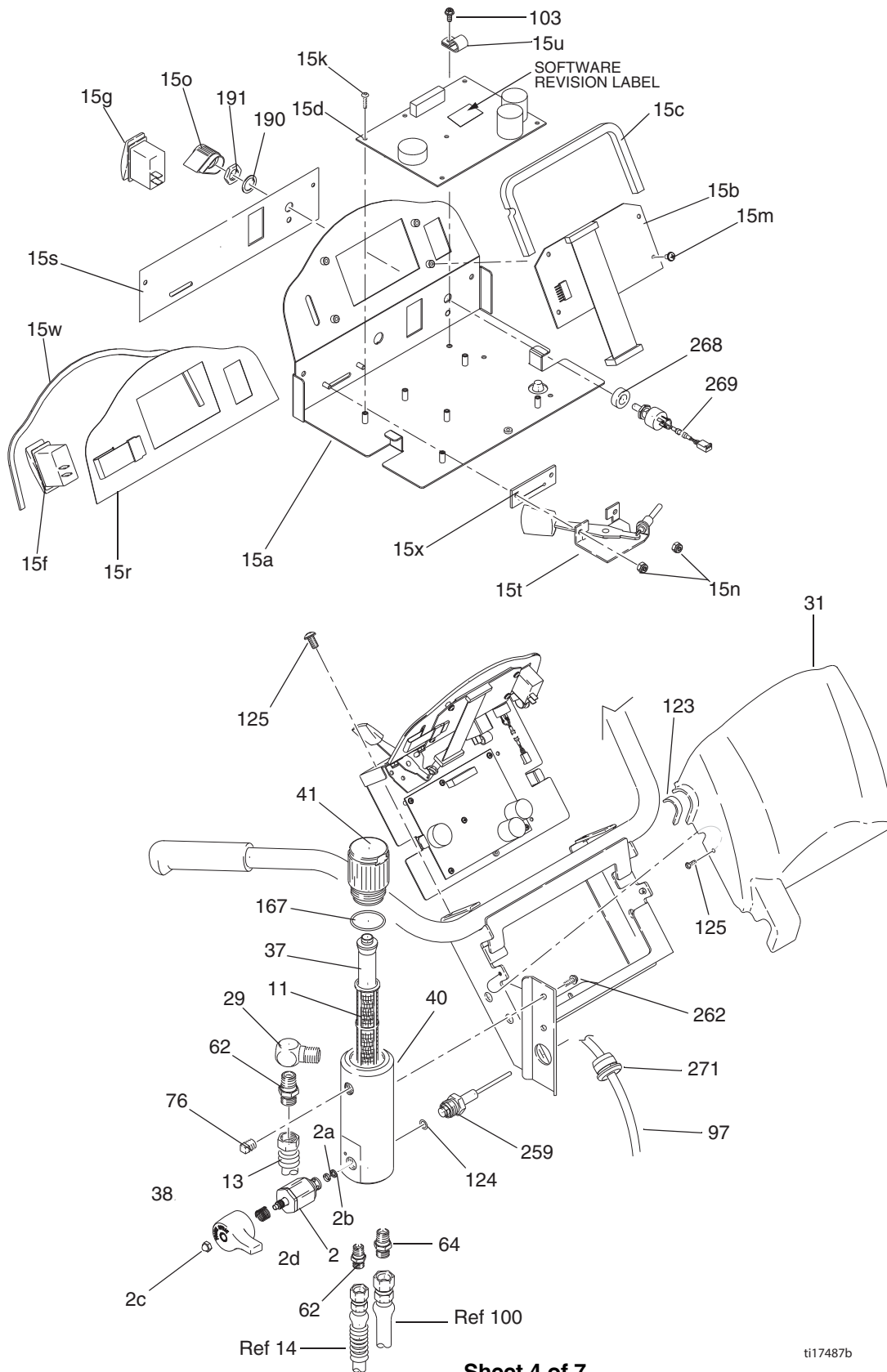

## LineLazer IV 200HS

Ref	Part	Description	Qty	Ref	Part	Description	Qty
2*	245103	VALVE, drain	1	62	196178	ADAPTER, nipple	2
2a	193709	SEAT, valve	1	64	196181	FITTING, nipple	1
2b	193710	SEAT, valve	1	76	104813	PLUG, pipe	1
2c	116424	NUT, cap	1	91		LABEL, kit, blank	2
2d	114708	SPRING	1	97	15K102	HARNESS, wiring	1
11*	244067	FILTER, fluid	1	103	117501	SCREW, mach, slot, hex wash hd	5
12	287687	KIT, repair, pressure control	1	123	118359	KNOB, pressure control	1
13	245225	HOSE, 3/8 in. x 50 ft	1	124*	111457	O-RING	1
15	289264	KIT, switch, panel, includes 15a, 15r, 15s, 15w	1	125	101962	SCREW, set, sch 1/4-20	1
15a	15G801	PLATE, control	1	167*	117285	O-RING	1
15b+	289265	BOARD, display, includes 15c, 15m	1	190	115999	RING, retaining	1
15c	15M509	GASKET, board	1	191	176754	GLAND, packing, male	1
15d+	289135	CONTROL, board, includes 15k	1	225	15A464	LABEL, warning	1
15f	114954	SWITCH, rocker	1	225	15A464	LABEL, control	1
15k	111839	SCREW, mach, pnh, sems	6	259*	287172	TRANSDUCER, pressure control, includes 124	
15m	120743	SCREW, mach, pan head, sems	4	262	111801	SCREW, cap, hex	2
15n	109466	NUT, lock, hex hd	2	268	15F710	BUSHING, mount panel	1
15r		SWITCH, membrane	1	269	119775	NUT, panel	1
15s		LABEL, control, bottom	1	271	111348	BUSHING, relief, strain	1
15t	287692	CONTROL, throttle	1	330	121276	PLUG, button	1
15u	119736	CLAMP, cable	1	331	15F814	GASKET, handle	1
15w	15F777	GASKET, control	1	332	116719	SCREW, 8/32, hex washer hd	1
15x	15F776	GASKET, throttle	1				
29	196179	FITTING, elbow, street	2				
31	15F589	COVER, control	1				
37*	15C766	TUBE, diffuser	1				
38*	15G563	HANDLE	1				
40*	15H561	MANIFOLD, filter, 3/8 npt	1				
41*	287285	KIT, repair, filter cap, includes 37, 167	1				

\* Included in Filter Repair Kit 288100  
+ When replacing 15B (display board), check software revision level of 15D (control board) on software revision label. If control board (15D) software revision is lower than 1.01.10, the control board (15D) must also be changed.

# LineLazer IV 200Hs

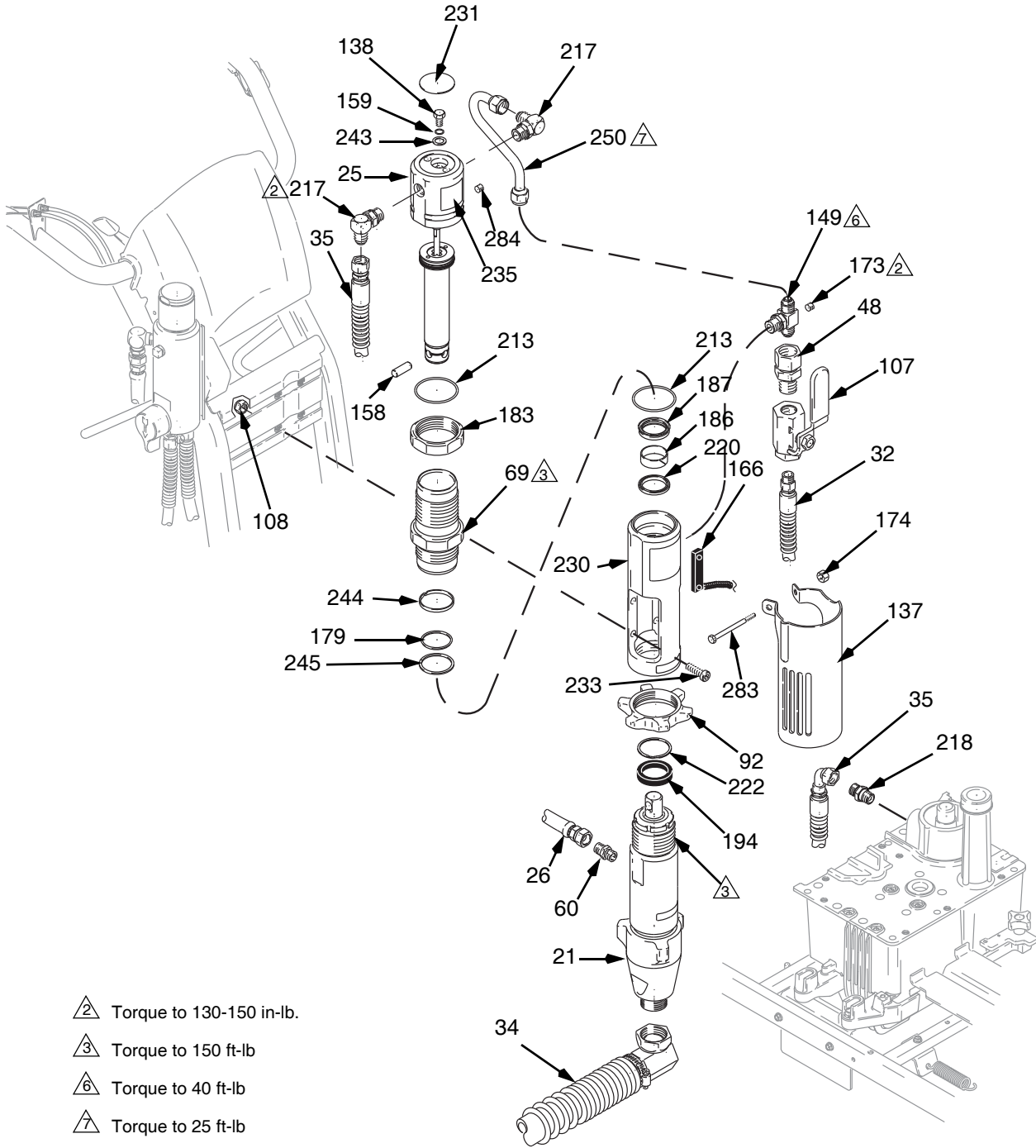



## LineLazer IV 200Hs

Ref	Part	Description	Qty	Ref	Part	Description	Qty
				183◆	15A726	NUT, jam	1
				186‡◆	112342	BEARING, rod	1
21	277068	PUMP, displacement Manual 309277	1	187‡◆	112561	PACKING, block	1
				194	116551	RING, retaining	1
25◆	288754	KIT, trip rod, piston, cap	1	213*‡◆	117283	O-RING	2
26	245797	HOSE, coupled, 3/8 in.	1	217	117607	FITTING, elbow, std thd	2
32	287175	HOSE, hydraulic, supply	1	218	117608	FITTING, nipple, straight	1
34	287206	HOSE, suction/drain	1	220‡◆	117739	WIPER, rod	1
35	287176	HOSE, hydraulic, return	1	222	287186	MAGNET, ring	1
48	117328	FITTING, nipple, straight	1	230	15A728	MANIFOLD, adapter	1
60	196176	ADAPTER, nipple	1	231*◆	15B063	LABEL,	1
69◆	246176	SLEEVE, hydraulic cylinder, includes 213	1	233	107210	SCREW, cap, socket head	4
				235◆	15B804	LABEL, Graco Logo	1
92	193394	NUT, retaining	1	243*◆	178179	WASHER, sealing	1
107	117441	VALVE, ball	1	244*‡◆	178207	BEARING, piston	1
108	101566	NUT, lock	4	245*‡◆	178226	SEAL, piston	1
137	15F911	GUARD, pump rod	1	249	197443	PIN, pump	1
138*◆	106276	SCREW, cap, hex hd	1	250	15F519	TUBE, hydraulic, supply	1
149	119841	FITTING, tee, branch, str thd	1	283	110982	SCREW, cap, hex head	1
158	116838	PIN, spring	2	284*◆	100139	PLUG, pipe, headless	1
159*◆	155685	O-RING	1				
166	119720	SWITCH, reed w/connector	2	*	Included in Trip Rod/Piston/Cap Repair Kit 288754		
173	100139	PLUG, pipe	1	‡	Included in Seal Repair Kit 246174		
174	102040	NUT, lock, hex	2	◆	Included in Hydraulic Motor Repair Kit 248021		
179*‡◆	108014	O-RING	1				

# LineLazer IV 200Hs

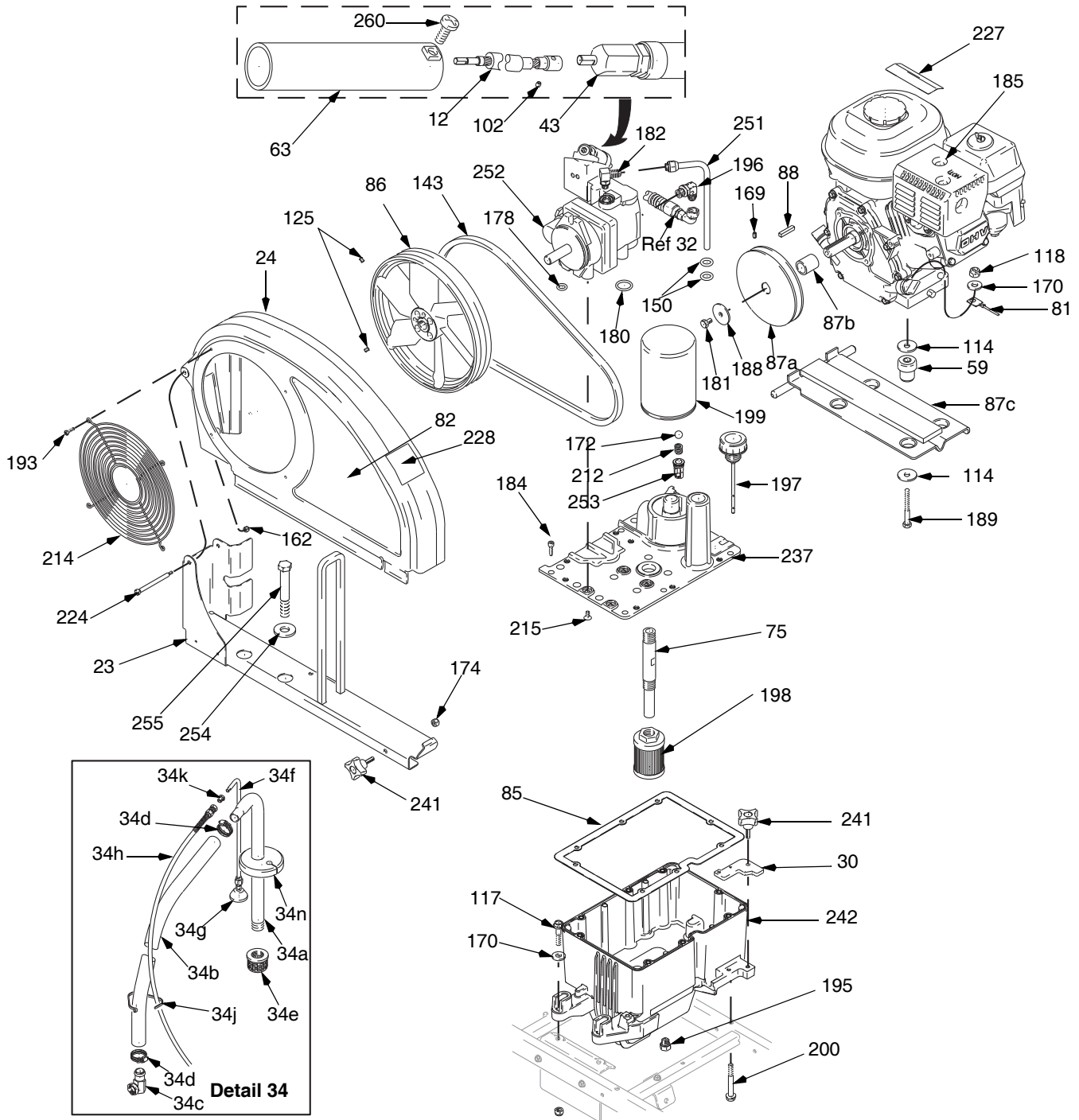

## LineLazer IV 200HS

Ref	Part	Description	Qty	Ref	Part	Description	Qty
12	287687	SHAFT, flexible, includes 102,	1	169	100002	SCREW, set, sch	1
23	288261	RAIL, belt	1	170	100023	WASHER, flat	6
24	288734	GUARD, belt, includes 162, 193, 214, 224, 228	1	172	100084	BALL, metallic	1
30	15E476	BRACKET, retainer, motor	1	174	102040	NUT, lock	1
34a	170957	TUBE, suction	1	178	107188	O-RING	1
34b	194306	HOSE, fluid	1	180	156401	O-RING	1
34c	198119	ELBOW, barbed	1	181	108842	SCREW, cap, hex head	1
34d	101818	CLAMP, hose	2	182	110792	ELBOW, male, 90 degree	1
34e	181072	STRAINER, inlet	1	184	119426	SCREW, cap, sch	8
34f	245731	TUBE, drain, includes 34g	1	185	116080	ENGINE, gas, 6.5 hp, Honda	1
34g	241920	DEFLECTOR, threaded	1	188	112717	WASHER,	1
34h	248008	HOSE, coupled 1/4 in. x 4 ft	1	189	113664	SCREW, flange, hex	4
34j	114958	STRAP, tie	7	193	115477	SCREW, mach, torx pan hd	4
34k	196180	BUSHING	1	195	101754	PLUG, hex head, hydraulic	1
34m	195119	LABEL, warning (not shown)	1	196	120634	FITTING, elbow, hydraulic	1
34n	15F513	GASKET, pail	1	197	120726	CAP, breather filler	1
43	15C400	ADAPTER, pressure control	1	198	116919	FILTER, hydraulic, suction	1
59	15E888	DAMPENER, motor mount	4	199	246173	FILTER, oil, spin on	1
63	15C958	GUARD, pressure control	1	200	120981	SCREW, hex washhd	2
75	15E587	TUBE, suction	1	212	116967	SPRING, compression	1
81	240997	CONDUCTOR, ground	1	214	117284	GRILL, fan guard	1
82	15K638	LABEL, brand 200HS	1	215	117471	SCREW, 1/4-20 flat hd mach	4
85	120604	GASKET, reservoir	1	224	119434	SCREW, shoulder, socket head	1
86	16U205	PULLEY, fan	1	227▲	194126	LABEL, warning	1
87a	15E758	PULLEY, 5.50 diameter	1	228▲	198492	LABEL, warning	1
87b	15E759	SPACER, shaft, engine	1	237	15M057	COVER, reservoir, GH200 LL	1
87c	15F485	BRACKET, engine mount	1	241	15D862	NUT, hand	2
88	117632	KEY, square, 3/16 X 1.25	1	242	15J513	TANK, reservoir	1
102	112303	SCREW, ste, socket w/patch	1	251	246167	TUBE, hydraulic, case drain, includes:150	1
114	108851	WASHER, plain	8	252	287179	PUMP, hydraulic, includes: 43, 102, 155, 178, 180, 215, 223, 238, 239, 240	1
117	110837	SCREW, flange, hex	10	253	198841	RETAINER, ball, press bypass	1
118	110838	NUT, lock	4	254	100527	WASHER, plain	2
125	101962	SCREW,set,1/4-2x.38	2	255	802277	SCREW, machine	2
143	119433	BELT, vee, gripnotch	1	260	112166	SCREW, cap, sch	7
150	154594	O-RING	2				
151	114956	TERMINAL, wire tap, insulated	1				
162	116969	NUT, lock	2				

▲ Replacement Warning Labels available at no cost.

# LineLazer IV 200Hs

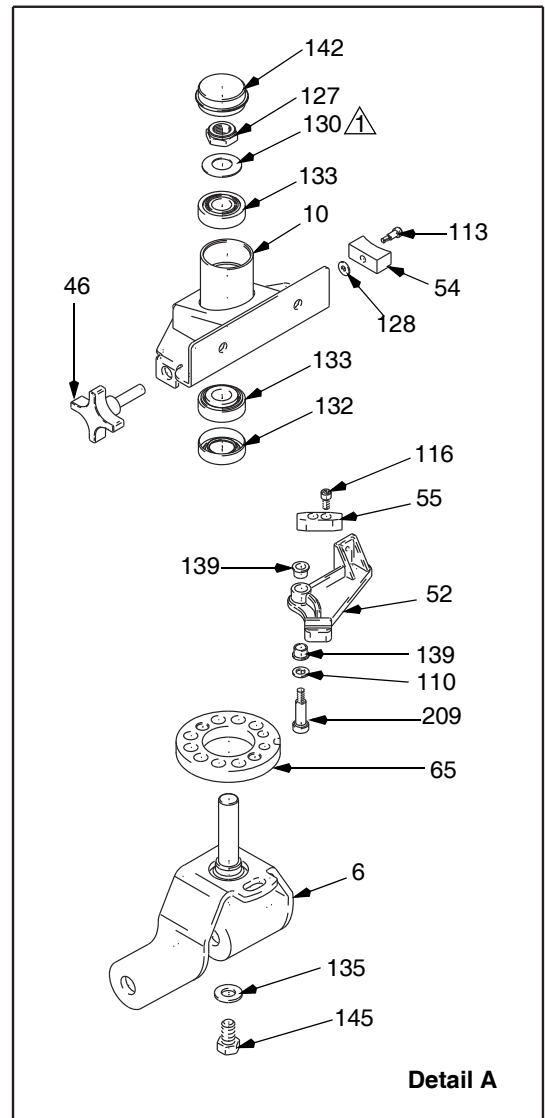
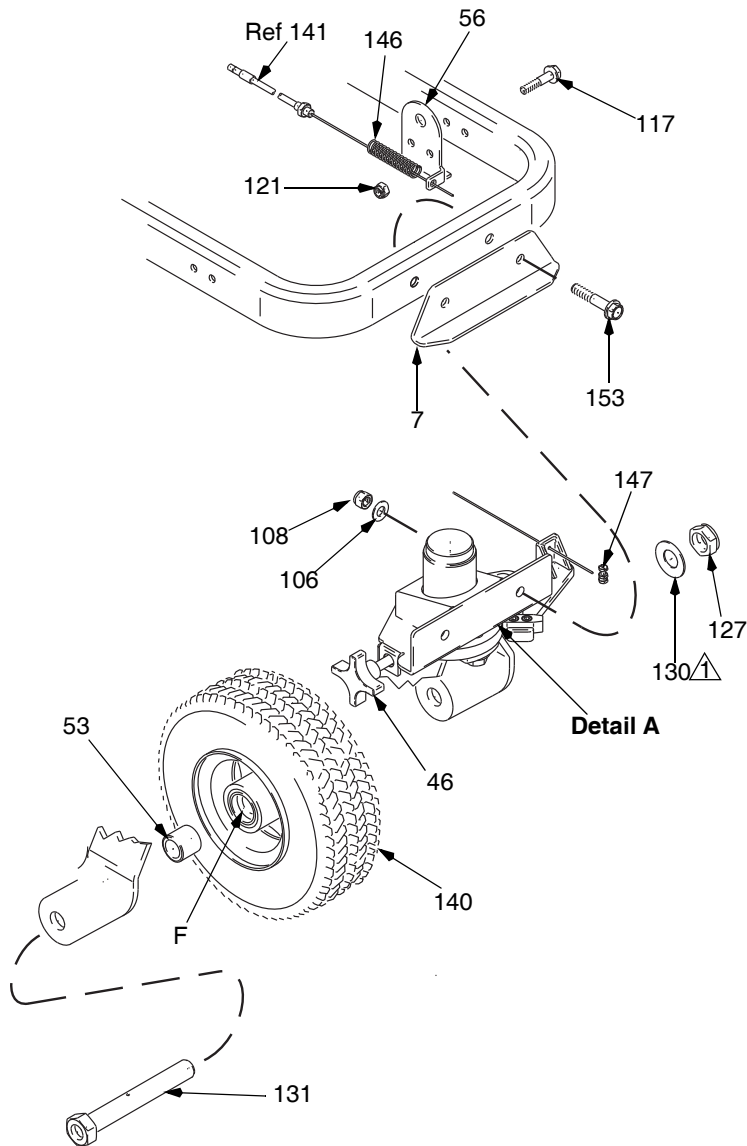

1 Install washers (130) concave surface to inside.

## LineLazer IV 200HS

### Swivel Wheel Assembly 240719

Ref	Part	Description	Qty	Ref	Part	Description	Qty
6	240942	SHAFT, fork	1	127	112405	NUT, lock	4
7	240991	BRACKET, caster, front	1	128	112776	WASHER, plain	1
10*	15G952	BRACKET, hub	1	130	119563	SPRING, Belleville	3
46	181818	KNOB, pronged	1	131	113471	SCREW, cap, hex hd	1
52	193528	ARM, detent	1	132*	113484	SEAL, grease	1
53	193658	SPACER, seal	2	133*	113485	BEARING, cup/cone	2
54	193661	JAW	1	135	113962	WASHER, hardened	1
55	193662	STOP, wedge	1	139	114548	BEARING, bronze	2
56	15F910	BRACKET, cable	1	140	114549	WHEEL, pneumatic	1
65	198606	DISK, adjuster	1	142	114648	CAP, dust	3
106	100731	WASHER	2	145	114681	SCREW, cap, hex hd	1
108	101566	NUT, lock	2	146	114682	SPRING, compression	1
110	15J603	WASHER, plain	1	147	114802	STOP, wire	1
113	108483	SCREW, shoulder, soc hd	1	153	114982	SCREW, cap, flng hd	2
116	110754	SCREW, cap, soc hd	2	209*	120476	BOLT	1
117	110837	SCREW, flange, hex	10				
121	111040	NUT, lock	2				

\* Included in 240940 Bracket Repair Kit; purchase separately

# Auto-Layout System Wiring Diagram

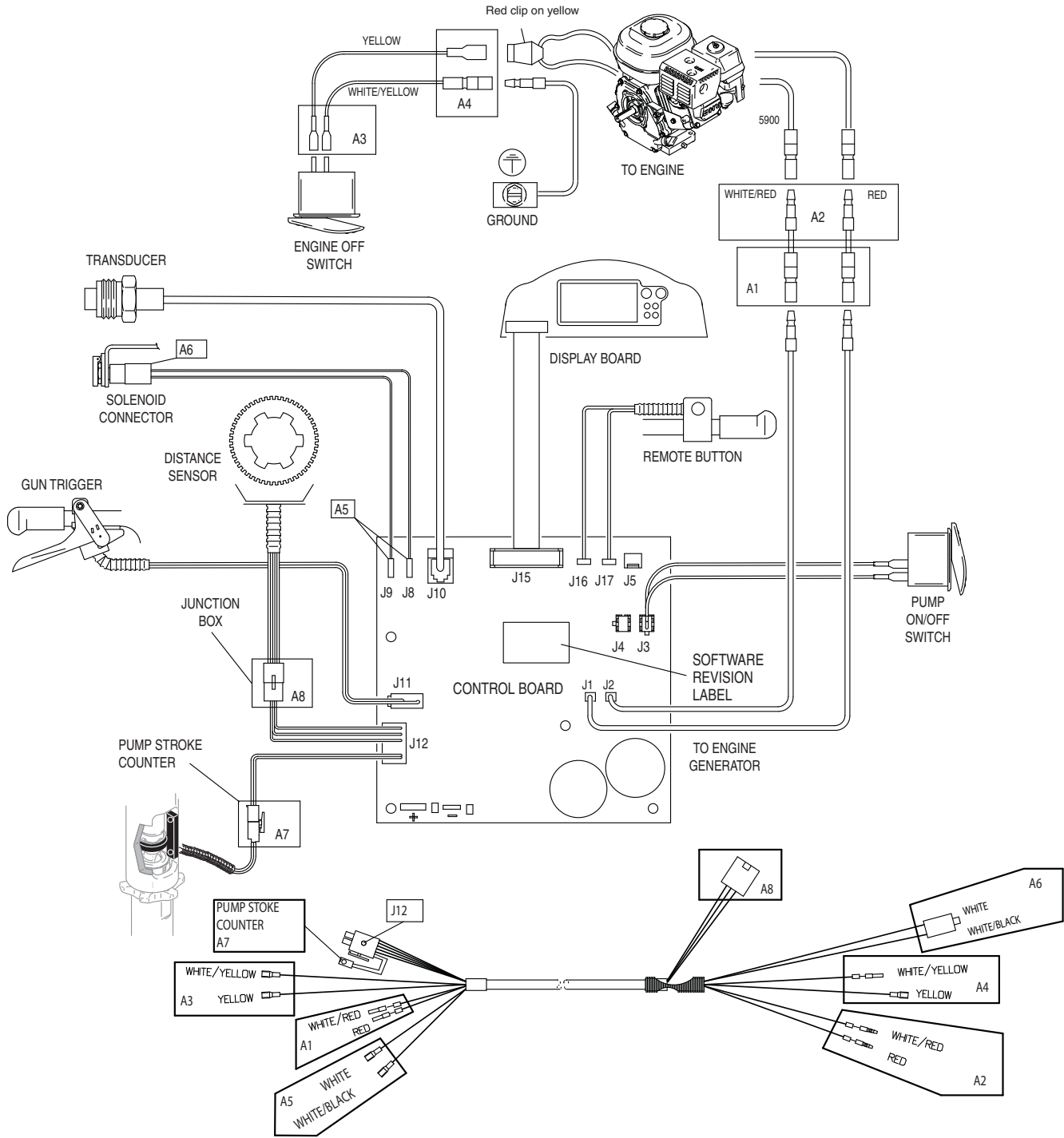

FIG. 17

## Technical Data

Engine	Honda GX 200cc
Engine Generator Output	70w
Maximum working pressure	3300 psi (228 bar, 22.8 MPa)
Noise Level	
Sound power	110 dBa, per ISO 3744
Sound pressure	96 dBa, measured at 3.1 feet (1 m)
*Vibration Level	
Left hand	2.90 m/sec <sup>2</sup>
Right hand	2.83 m/sec <sup>2</sup>
* Vibration measured per ISO 5349 based on 8 hour daily exposure	
Cycles/gallon (liter)	104 (27.5)
Maximum delivery	2.0 gpm (7.64 liter/min)
Maximum tip size	
1 gun	with 0.046 in. tip
2 guns	with 0.033 in. tip
Inlet paint strainer	16 mesh (1190 micron) stainless steel screen, reusable
Outlet paint strainer	60 mesh (250 micron) stainless steel screen, reusable
Pump inlet size	1 in. npsm(m)
Fluid outlet size	3/8 npt(f)
Hydraulic reservoir capacity	1.25 gallon (4.73 liters)
Hydraulic pressure	1825 psi (124 bar)
Weight (dry, without packaging)	242 lb (110 kg)
Height	40 in. (101.6 cm)
Length	65 in. (165.1 cm)
Width	32 in. (81.3 cm)
Wetted parts	PTFE, Nylon, polyurethane, V-Max™ UHMW polyethylene, fluoroelastomer, acetal, leather, tungsten carbide, stainless steel, chrome plating, nickel-plated carbon steel, ceramic

## Accessories

Must be purchased separately.

### GRACO-APPROVED HYDRAULIC OIL

169236	5 gallons (19 liters)
207428	1 gallon (3.8 liters)

# Graco Standard Warranty

Graco warrants all equipment referenced in this document which is manufactured by Graco and bearing its name to be free from defects in material and workmanship on the date of sale to the original purchaser for use. With the exception of any special, extended, or limited warranty published by Graco, Graco will, for a period of twelve months from the date of sale, repair or replace any part of the equipment determined by Graco to be defective. This warranty applies only when the equipment is installed, operated and maintained in accordance with Graco's written recommendations.

This warranty does not cover, and Graco shall not be liable for general wear and tear, or any malfunction, damage or wear caused by faulty installation, misapplication, abrasion, corrosion, inadequate or improper maintenance, negligence, accident, tampering, or substitution of non-Graco component parts. Nor shall Graco be liable for malfunction, damage or wear caused by the incompatibility of Graco equipment with structures, accessories, equipment or materials not supplied by Graco, or the improper design, manufacture, installation, operation or maintenance of structures, accessories, equipment or materials not supplied by Graco.

This warranty is conditioned upon the prepaid return of the equipment claimed to be defective to an authorized Graco distributor for verification of the claimed defect. If the claimed defect is verified, Graco will repair or replace free of charge any defective parts. The equipment will be returned to the original purchaser transportation prepaid. If inspection of the equipment does not disclose any defect in material or workmanship, repairs will be made at a reasonable charge, which charges may include the costs of parts, labor, and transportation.

**THIS WARRANTY IS EXCLUSIVE, AND IS IN LIEU OF ANY OTHER WARRANTIES, EXPRESS OR IMPLIED, INCLUDING BUT NOT LIMITED TO WARRANTY OF MERCHANTABILITY OR WARRANTY OF FITNESS FOR A PARTICULAR PURPOSE.**

Graco's sole obligation and buyer's sole remedy for any breach of warranty shall be as set forth above. The buyer agrees that no other remedy (including, but not limited to, incidental or consequential damages for lost profits, lost sales, injury to person or property, or any other incidental or consequential loss) shall be available. Any action for breach of warranty must be brought within two (2) years of the date of sale.

**GRACO MAKES NO WARRANTY, AND DISCLAIMS ALL IMPLIED WARRANTIES OF MERCHANTABILITY AND FITNESS FOR A PARTICULAR PURPOSE, IN CONNECTION WITH ACCESSORIES, EQUIPMENT, MATERIALS OR COMPONENTS SOLD BUT NOT MANUFACTURED BY GRACO.** These items sold, but not manufactured by Graco (such as electric motors, switches, hose, etc.), are subject to the warranty, if any, of their manufacturer. Graco will provide purchaser with reasonable assistance in making any claim for breach of these warranties.

In no event will Graco be liable for indirect, incidental, special or consequential damages resulting from Graco supplying equipment hereunder, or the furnishing, performance, or use of any products or other goods sold hereto, whether due to a breach of contract, breach of warranty, the negligence of Graco, or otherwise.

## **FOR GRACO CANADA CUSTOMERS**

The Parties acknowledge that they have required that the present document, as well as all documents, notices and legal proceedings entered into, given or instituted pursuant hereto or relating directly or indirectly hereto, be drawn up in English. Les parties reconnaissent avoir convenu que la rédaction du présente document sera en Anglais, ainsi que tous documents, avis et procédures judiciaires exécutés, donnés ou intentés, à la suite de ou en rapport, directement ou indirectement, avec les procédures concernées.

## **POUR LES CLIENTS DE GRACO PARLANT FRANCAIS**

Les parties reconnaissent avoir convenu que la rédaction du présent document ainsi que de tous les documents, avis et procédures judiciaires exécutés, donnés ou intentés à la suite de ou en rapport, directement ou indirectement, avec les procédures concernées, sera en anglais.

## **ADDITIONAL WARRANTY COVERAGE**

Graco does provide extended warranty and wear warranty for products described in the "Graco Contractor Equipment Warranty Program".

# Graco Information

For the latest information about Graco products, visit [www.graco.com](http://www.graco.com).

For patent information, see [www.graco.com/patents](http://www.graco.com/patents).

**TO PLACE AN ORDER**, contact your Graco distributor or call 1-800-690-2894 to identify the nearest distributor.

*All written and visual data contained in this document reflects the latest product information available at the time of publication.  
Graco reserves the right to make changes at any time without notice.*

For patent information, see [www.graco.com/patents](http://www.graco.com/patents).

Original instructions. This manual contains English. MM 312226

**Graco Headquarters:** Minneapolis  
**International Offices:** Belgium, China, Japan, Korea

**GRACO INC. AND SUBSIDIARIES • P.O. BOX 1441 • MINNEAPOLIS MN 55440-1441 • USA**

**Copyright 2007, Graco Inc. All Graco manufacturing locations are registered to ISO 9001.**

[www.graco.com](http://www.graco.com)  
Revised P, July 2017