

Repair



LineLazer™ 3400 Airless Line Striper

311019C

- For the application of line striping materials -

3300 psi (22.8 MPa, 228 bar) Maximum Working Pressure



Read all warnings and instructions

Models: 248861, 249007



311016



309741



309250



309640

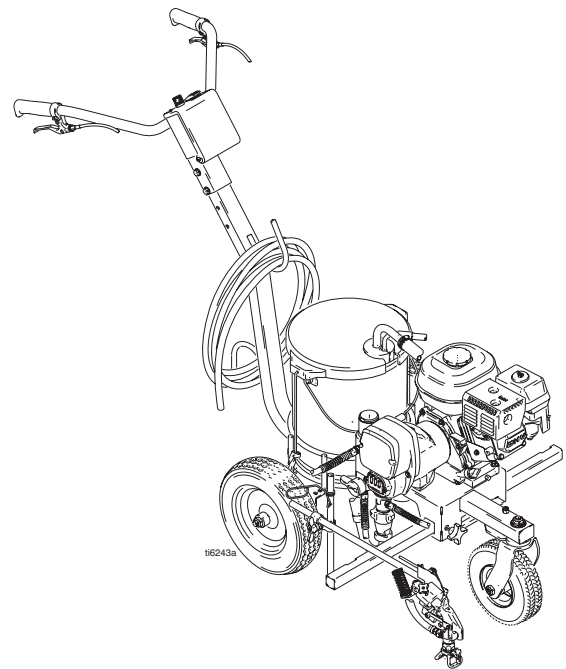

PROVEN QUALITY. LEADING TECHNOLOGY.

Graco Inc. P.O. Box 1441 Minneapolis, MN 55440-1441
Copyright 2005, Graco Inc. is registered to I.S. EN ISO 9001





Contents

WARNING 3
Maintenance 5
Troubleshooting 6
Drive Housing and Connecting Rod 8
Pinion Assembly/Clutch Armature/Clamp 9
Clutch Housing 11
Engine 11
Pressure Control 12
Displacement Pump 14

Parts 16
Pinion Housing 18
Gun Arm Parts 22
Pressure Control/Filter Assembly 22
Pressure Control Wiring Diagram 23
Technical Data 25
Dimensions 25
Graco Standard Warranty 26

Manual Conventions

 WARNING  Hazard Symbol
<p>WARNING: a potentially hazardous situation which, if not avoided, could result in death or serious injury.</p> <p>Warnings in the instructions usually include a symbol indicating the hazard. Read the general Warnings section for additional safety information.</p>





CAUTION
<p>CAUTION: a potentially hazardous situation which, if not avoided, may result in property damage or destruction of equipment.</p>











Note

 Additional helpful information.

Warning

The following warnings include general safety information for this equipment. Further product specific warnings may be included in the text where applicable.

 WARNING	
	<p>FIRE AND EXPLOSION HAZARD</p> <p>Flammable fumes, such as solvent and paint fumes, in work area can ignite or explode. To help prevent fire and explosion:</p> <ul style="list-style-type: none"> • Use equipment only in well ventilated area. • Do not fill fuel tank while engine is running or hot; shut off engine and let it cool. Fuel is flammable and can ignite or explode if spilled on hot surface. • When flammable liquid is sprayed or used for flushing or cleaning, keep sprayer at least 20 feet (6 m) away from explosive vapors. • Eliminate all ignition sources; such as pilot lights, cigarettes, portable electric lamps, and plastic drop cloths (potential static arc). • Keep work area free of debris, including solvent, rags and gasoline. • Do not plug or unplug power cords, or turn power or light switches on or off when flammable fumes are present. • Ground equipment and conductive objects in work area. See Grounding instructions. • Use only grounded hoses. • Hold gun firmly to side of grounded pail when triggering into pail. • If there is static sparking or you feel a shock, stop operation immediately. Do not use equipment until you identify and correct the problem.
	<p>SKIN INJECTION HAZARD</p> <p>High-pressure fluid from gun, hose leaks, or ruptured components will pierce skin. This may look like just a cut, but it is a serious injury that can result in amputation. Get immediate surgical treatment.</p> <ul style="list-style-type: none"> • Do not point gun at anyone or at any part of the body. • Do not put your hand over the spray tip. • Do not stop or deflect leaks with your hand, body, glove, or rag. • Do not spray without tip guard and trigger guard installed. • Engage trigger lock when not spraying. • Follow Pressure Relief Procedure in this manual, when you stop spraying and before cleaning, checking, or servicing equipment.
	<p>PRESSURIZED EQUIPMENT HAZARD</p> <p>Fluid from the gun/dispense valve, leaks, or ruptured components can splash in the eyes or on skin and cause serious injury.</p> <ul style="list-style-type: none"> • Follow Pressure Relief Procedure in this manual, when you stop spraying and before cleaning, checking, or servicing equipment. • Tighten all fluid connections before operating the equipment. • Check hoses, tubes, and couplings daily. Replace worn or damaged parts immediately.
	<p>MOVING PARTS HAZARD</p> <p>Moving parts can pinch or amputate fingers and other body parts.</p> <ul style="list-style-type: none"> • Keep clear of moving parts. • Do not operate equipment with protective guards or covers removed. • Pressurized equipment can start without warning. Before checking, moving, or servicing equipment, follow the Pressure Relief Procedure in this manual. Disconnect power or air supply.

 WARNING	
	<p>EQUIPMENT MISUSE HAZARD</p> <p>Misuse can cause death or serious injury.</p> <ul style="list-style-type: none"> Do not exceed the maximum working pressure or temperature rating of the lowest rated system component. See Technical Data in all equipment manuals. Use fluids and solvents that are compatible with equipment wetted parts. See Technical Data in all equipment manuals. Read fluid and solvent manufacturer's warnings. Check equipment daily. Repair or replace worn or damaged parts immediately. Do not alter or modify equipment. Use equipment only for its intended purpose. Call your Graco distributor for information. Route hoses and cables away from traffic areas, sharp edges, moving parts, and hot surfaces. Do not use hoses to pull equipment. Keep children and animals away from work area. Comply with all applicable safety regulations.
	<p>PRESSURIZED ALUMINUM PARTS HAZARD</p> <p>Do not use 1,1,1-trichloroethane, methylene chloride, other halogenated hydrocarbon solvents or fluids containing such solvents in pressurized aluminum equipment. Such use can cause serious chemical reaction and equipment rupture, and result in death, serious injury, and property damage.</p>
	<p>SUCTION HAZARD</p> <p>Never place hands near the pump fluid inlet when pump is operating or pressurized. Powerful suction could cause serious injury.</p>
	<p>CARBON MONOXIDE HAZARD</p> <p>Exhaust contains poisonous carbon monoxide, which is colorless and odorless. Breathing carbon monoxide can cause death. Do not operate in an enclosed area.</p>
	<p>TOXIC FLUID OR FUMES HAZARD</p> <p>Toxic fluids or fumes can cause serious injury or death if splashed in the eyes or on skin, inhaled, or swallowed.</p> <ul style="list-style-type: none"> Read MSDS's to know the specific hazards of the fluids you are using. Store hazardous fluid in approved containers, and dispose of it according to applicable guidelines.
	<p>BURN HAZARD</p> <p>Equipment surfaces and fluid that's heated can become very hot during operation. To avoid severe burns, do not touch hot fluid or equipment. Wait until equipment/fluid has cooled completely.</p>
  	<p>PERSONAL PROTECTIVE EQUIPMENT</p> <p>You must wear appropriate protective equipment when operating, servicing, or when in the operating area of the equipment to help protect you from serious injury, including eye injury, inhalation of toxic fumes, burns, and hearing loss. This equipment includes but is not limited to:</p> <ul style="list-style-type: none"> Protective eyewear Clothing and respirator as recommended by the fluid and solvent manufacturer Gloves Hearing protection
	<p>RECOIL HAZARD</p> <p>Brace yourself; gun may recoil when triggered and cause you to fall, which could cause serious injury.</p>

Maintenance

Pressure Relief Procedure

 WARNING  
Read Injection Hazard, page 3; Burn Hazard, page 4

1. Lock gun trigger safety.
2. Turn engine ON/OFF switch to OFF.
3. Move pump switch to OFF and turn pressure control knob fully counterclockwise.
4. Unlock trigger safety. Hold metal part of gun firmly to side of grounded metal pail, and trigger gun to relieve pressure.
5. Lock gun trigger safety.
6. Open pressure drain valve. Leave valve open until ready to spray again.

If you suspect that the spray tip or hose is completely clogged, or that pressure has not been fully relieved after following the steps above, VERY SLOWLY loosen tip guard retaining nut or hose end coupling to relieve pressure gradually, then loosen completely. Now clear tip or hose.

CAUTION
For detailed engine maintenance and specifications, refer to separate Honda Engines Owner's Manual, supplied.

DAILY: Check engine oil level and fill as necessary.

DAILY: Check hose for wear and damage.

DAILY: Check gun safety for proper operation.

DAILY: Check pressure drain valve for proper operation.

DAILY: Check and fill the gas tank.

DAILY: Check level of TSL in displacement pump packing nut. Fill nut, if necessary. Keep TSL in nut to help prevent fluid buildup on piston rod and premature wear of packings and pump corrosion.

AFTER THE FIRST 20 HOURS OF OPERATION:

Drain engine oil and refill with clean oil. Reference Honda Engines Owner's Manual for correct oil viscosity.

WEEKLY: Remove engine air filter cover and clean element. Replace element, if necessary. If operating in an unusually dusty environment: check filter daily and replace, if necessary.

Replacement elements can be purchased from your local HONDA dealer.

AFTER EACH 100 HOURS OF OPERATION:

Change engine oil. Reference Honda Engines Owner's Manual for correct oil viscosity.

SPARK PLUG: Use only BPR6ES (NGK) or W20EPR-U (NIPPONDENSO) plug. Gap plug to 0.028 to 0.031 in. (0.7 to 0.8 mm). Use spark plug wrench when installing and removing plug.

Front Wheel Alignment:

Align front wheel as follows:

1. Fig. Loosen cap screw (90).

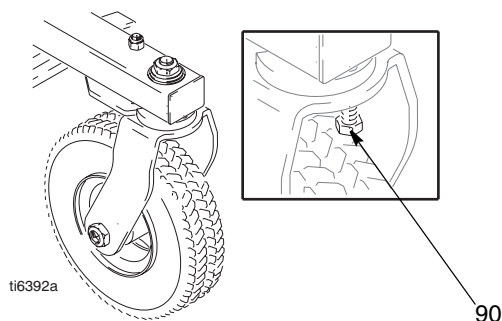

FIG. 1

2. Position front wheel left or right, as necessary, to straighten alignment.
3. Tighten cap screw (90). Push striper and let striper roll with hands off of striper. Note if striper rolls straight or veers right or left. Repeat steps 1 and 2 until striper rolls straight.

Troubleshooting

Problem	Cause	Solution
Engine will not start	Engine switch is OFF	Turn engine switch ON
	Engine is out of gasoline	Refill gas tank. Honda Engines Owner's Manual.
	Engine oil level is low	Check oil level. Replenish oil, if necessary. Honda Engines Owner's Manual.
	Spark plug is disconnected or damaged	Connect spark plug cable or replace spark plug
	Cold engine	Use choke
	Fuel shutoff lever is OFF	Move lever to ON position
	Oil is seeping into combustion chamber	Remove spark plug. Pull starter 3 to 4 times. Clean or replace spark plug. Start engine. Keep sprayer upright to avoid oil seepage
Engine operates, but displacement pump does not operate	Pump switch is OFF	Turn pump switch ON
	Pressure setting too low	Turn pressure adjusting knob clockwise to increase pressure.
	Fluid filter (104) is dirty	Clean filter. Page 22.
	Tip or tip filter is clogged	Clean tip or tip filter. Manual 309741.
	Displacement pump piston rod is stuck due to dried paint	Repair pump. Manual 309250.
	Connecting rod is worn or damaged	Replace connecting rod. Page 8.
	Drive housing is worn or damaged	Replace drive housing. Page 8.
	Electrical power is not energizing clutch field	Check wiring connections. Page 11, 12.
		<p>Reference pressure control repair. Page 13.</p> <p>Reference wiring diagram. Page 23.</p> <p>With pump switch ON and pressure turned to MAXIMUM, use a test light to check for power between clutch test points on control board.</p> <p>Remove clutch wires from control board and measure resistance across clutch coil. At 70° F, the resistance must be between 1.2 +0.2Ω; if not, replace pinion housing.</p> <p>Have pressure control checked by authorized Graco dealer</p>
Clutch is worn, damaged, or incorrectly positioned	Adjust or replace clutch. Page 9.	
Pinion assembly is worn or damaged	Repair or replace pinion assembly. Page 9.	

Problem	Cause	Solution
Pump output is low	Strainer (56) is clogged	Clean strainer.
	Piston ball (206) is not seating	Service piston ball. Manual 309250.
	Piston packings are worn or damaged	Replace packings. Manual 309250.
	O-ring (227) in pump is worn or damaged	Replace o-ring. Manual 309250.
	Intake valve ball is not seating properly	Clean intake valve. Manual 309250.
	Intake valve ball is packed with material	Clean intake valve. Manual 309250.
	Engine speed is too low	Increase throttle setting. Manual 311016.
	Clutch is worn or damaged	Adjust or replace clutch. Page 9.
	Pressure setting is too low	Increase pressure. Manual 311016.
	Fluid filter (104), tip filter or tip is clogged or dirty	Clean filter. Manual 311016 or 309741.
	Large pressure drop in hose with heavy materials	Use larger diameter hose and/or reduce overall length of hose. Use of more than 100 ft of 1/4 in. hose significantly reduces performance of sprayer. Use 3/8 in. hose for optimum performance (50 ft minimum).
Excessive paint leakage into throat packing nut	Throat packing nut is loose	Remove throat packing nut spacer. Tighten throat packing nut just enough to stop leakage.
	Throat packings are worn or damaged	Replace packings. Manual 309250.
	Displacement rod is worn or damaged	Replace rod. Manual 309250.
Fluid is spitting from gun	Air in pump or hose	Check and tighten all fluid connections. Reprime pump. Manual 311016.
	Tip is partially clogged	Clear tip. Manual 309639.
	Fluid supply is low or empty	Refill fluid supply. Prime pump. Manual 311016. Check fluid supply often to prevent running pump dry.
Pump is difficult to prime	Air in pump or hose	Check and tighten all fluid connections. Reduce engine speed and cycle pump as slowly as possible during priming.
	Intake valve is leaking	Clean intake valve. Be sure ball seat is not nicked or worn and that ball seats well. Reassemble valve.
	Pump packings are worn	Replace pump packings. Manual 309250.
	Paint is too thick	Thin the paint according to the supplier's recommendations
	Engine speed is too high	Decrease throttle setting before priming pump. Manual 311016.
Clutch squeaks each time clutch engages	Clutch surfaces are not matched to each other when new and may cause noise	Clutch surfaces need to wear into each other. Noise will dissipate after a day of run time.
High engine speed at no load	Misadjusted throttle setting	Reset throttle to 3300 engine rpm at no load
	Worn engine governor	Replace or service engine governor

Drive Housing and Connecting Rod

Removal

WARNING



Read Injection Hazard, page 3; Burn Hazard, page 4

1. Relieve pressure, page 5.
2. FIG. 2. Remove screws (32) and front cover (52).
3. Remove pump. Refer to **Displacement Pump, Removal**, page 14.
4. Remove four screws (34) from drive housing (43).

CAUTION

Thrust washers may stick to grease inside of drive housing. Do not lose or misplace.

5. Pull connecting rod (29) and lightly tap lower rear of drive housing (43) with plastic mallet to loosen from pinion housing (44). Pull drive housing and connecting rod assembly off pinion housing.
6. Inspect crank (47) and connecting rod (29) for excessive wear and replace parts as needed.

Installation

1. Evenly lubricate inside of bronze bearing (C) in drive housing (43) with high-quality motor oil. Liberally pack top roller bearing (E), lower bearing (D) inside connecting rod (29) with bearing grease.
2. Assemble connecting rod (29) to drive housing (43). Rotate connecting rod to lowest position.
3. Apply grease to washers 46, 49 and 48. Install in order shown in FIG. 3.
4. Lubricate gears with 0.26 pint of 110293 grease (supplied with drive housing). Pack grease evenly around gears.
5. Clean mating surfaces of pinion and drive housings.
6. Align connecting rod with crank (47) and carefully align locating pins in drive housing (43) with holes in pinion housing (44). Push drive housing onto pinion housing or tap into place with plastic mallet.

CAUTION

DO NOT use drive housing screws (34) to align or seat bearing housing with drive housing. Align these parts with locating pins, to avoid premature bearing wear.

7. Install screws (34) in drive housing. Torque evenly to note 3 value in Fig. 1.
8. Install pump. Refer to **Displacement Pump, Installation**, page 14
9. Install front cover (52) with two screws (32)..

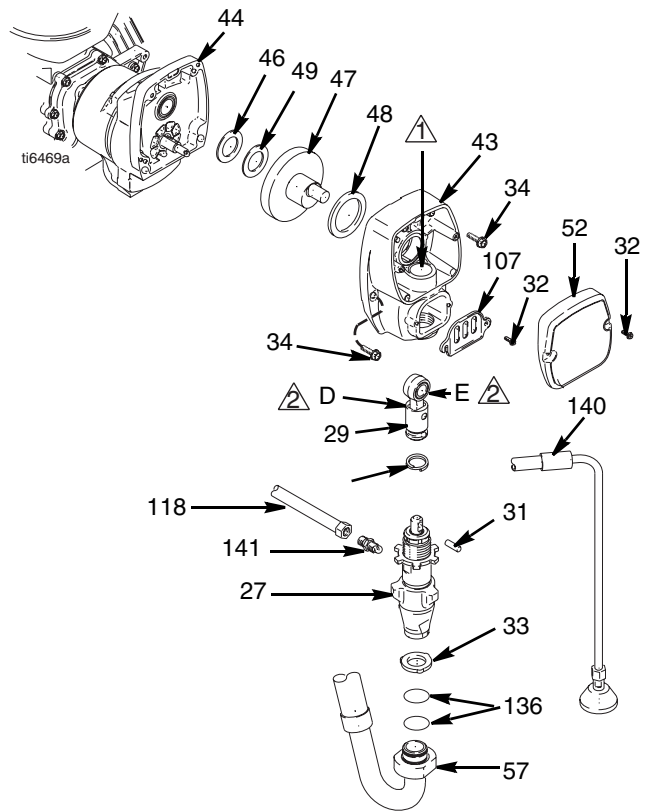



-  Oil
-  Pack with bearing grease 110293
-  Torque to 130 - 150 in-lb (14 - 16.9 N.m)

FIG. 2

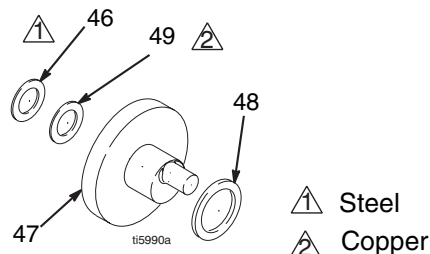

FIG. 3



Pinion Assembly/Clutch Armature/Clamp

Pinion Assembly/Clutch Armature Removal

Pinion Assembly

If pinion assembly (44) is not removed from clutch housing (45), do 1. through 3. Otherwise, start at 4.

⚠ WARNING

Read Injection Hazard, page 3; Burn Hazard, page 4

1. Relieve pressure, page 5.
2. Remove drive housing; page 8.
3. FIG. 11. Disconnect clutch (+) and clutch (-) connectors from wire harness located under sprayer cart.
4. FIG. 4. Remove four screws (18) and pinion assembly (44).

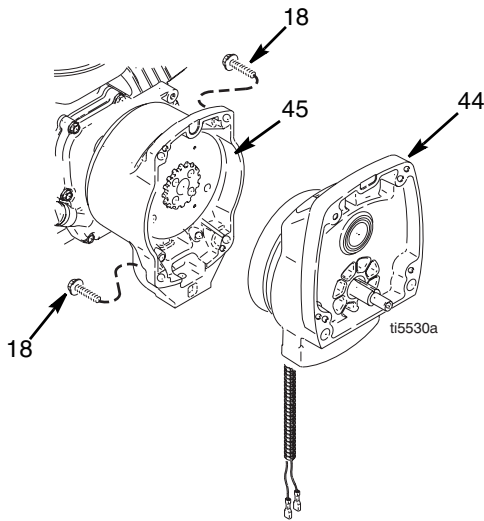

FIG. 4

5. FIG. 5. Place pinion assembly (44) on bench with rotor side up.
6. Remove four screws (42) and lock washers (35). Install two screws in threaded holes (E) in rotor. Alternately tighten screws until rotor comes off.

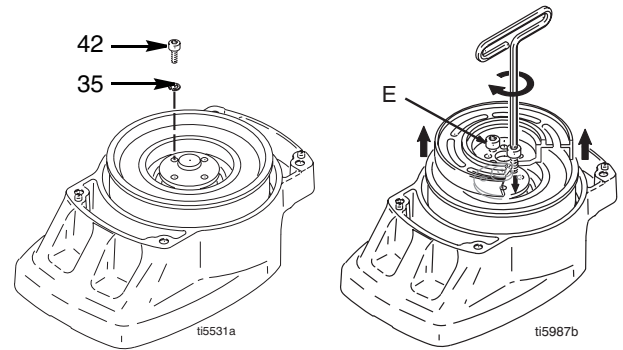

FIG. 5

7. FIG. 6. Remove retaining ring (44d).
8. Turn pinion assembly over and tap pinion shaft (44c) out with plastic mallet.

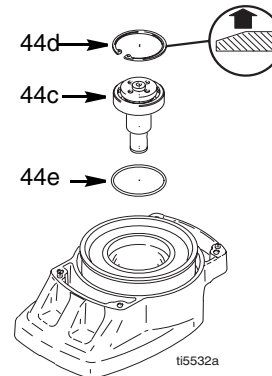

FIG. 6

Clutch Armature

9. FIG. 7. Use an impact wrench or wedge something between clutch armature (39) and clutch housing to hold engine shaft during removal.
10. Remove four screws (36) and lock washers (35).
11. Remove armature (39).

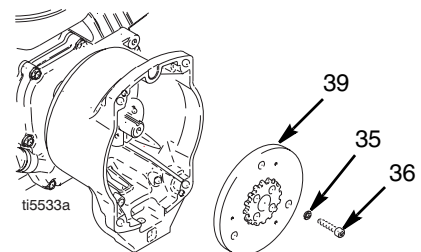

FIG. 7

Installation

Clutch Armature

- FIG. 8. Lay two stacks of two dimes on smooth bench surface.
- Lay armature (39) on two stacks of dimes.
- Press center of hub down to bench surface.

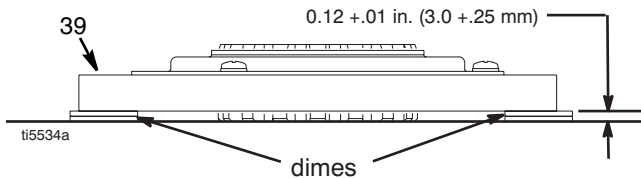
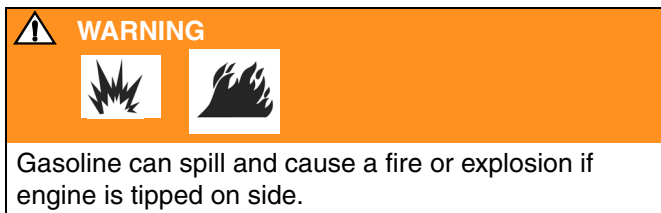

FIG. 8

Clamp Removal

- Do **Engine Removal**.



- Drain gasoline from tank according to Honda manual.
- FIG. 9. Tip engine on side so gas tank is down and air cleaner is up.
- FIG. 10. Loosen two screws (36) on clamp (38),
- Push screwdriver into slot in clamp (38) and remove clamp.

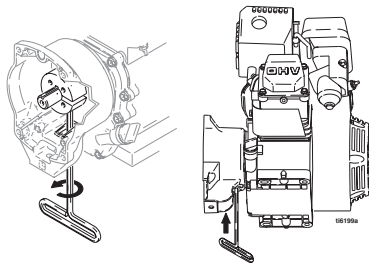

FIG. 9

Clamp Installation

- FIG. 10 Install engine shaft key (37)
- Tap clamp (38) onto engine shaft (A). Maintain dimension shown note 2. Chamfer must face engine.
- Check dimension: Place rigid, straight steel bar (B) across face of clutch housing (45). Use accurate measuring device to measure distance between bar and face of clamp. Adjust clamp as necessary. Torque two screws (36) to 125 ± 10 in-lb (14 ± 1.1 N-m)

- Install armature (39) on engine drive shaft.
- Install four screws (36) and lock washers (35) with torque of 125 in-lb.

Pinion Assembly

- FIG. 6. Install o-ring (44e).
- Tap pinion shaft (44c) in with plastic mallet.
- Install retaining ring (44d) with beveled side facing up.
- FIG. 5. Place pinion assembly on bench with rotor side up.
- Apply locktite to screws. Install four screws (42) and lock washers (35). Alternately torque screws to 125 in-lb until rotor is secure. Use threaded holes to hold rotor.
- FIG. 4. Install pinion assembly (44) with four screws (18).
- Connect clutch (+) and clutch (-) connectors to wire harness.

① Face of clutch housing

② 1.550 ± 0.010 in. (39.37 ± 0.25 mm)

③ Torque to 125 ± 10 in-lb (14 ± 1.1 N-m)

④ Chamfer this side

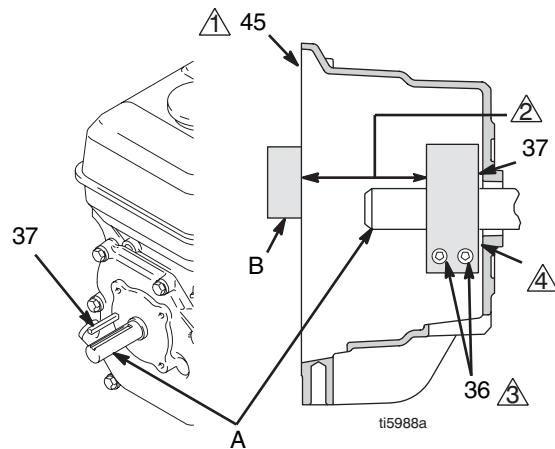

FIG. 10

Clutch Housing

Removal

1. Remove clamp. Do **Clamp Removal**, page 10.
2. FIG. 11. Remove four screws (51) and lock washers (50) which hold clutch housing (45) to engine.
3. Remove screw (145) from under mounting plate.
4. Pull off clutch housing (45).

Installation

1. FIG. 11. Push on clutch housing (45).
2. Install four capscrews (51) and lock washers (56) and secure clutch housing (45) to engine. Torque to 200 in-lb (22.6 N·m).
3. Install screw (145) from beneath mounting plate. Torque to 26 ft-lb (35.2 N·m).

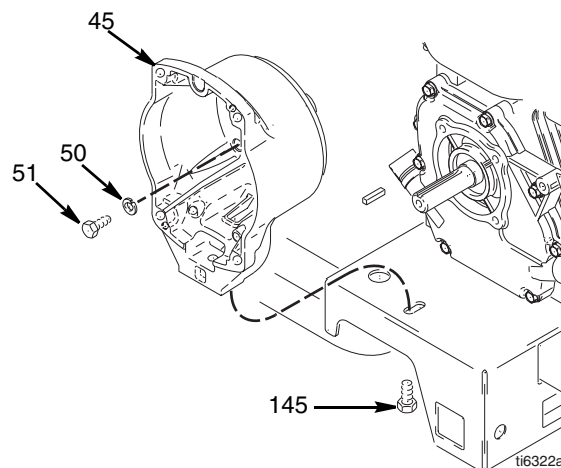

FIG. 11

Engine

Removal

NOTE: All service to the engine must be performed by an authorized HONDA dealer.

1. Remove **Pinion Assembly/Clutch Armature/Clamp** and **Clutch Housing**, as instructed on pages 9, 10 and 11.
2. FIG. 12. Disconnect all necessary wiring.
3. FIG. 13. Remove two locknuts (111) and screws (110) from base of engine.
4. Lift engine carefully and place on work bench.

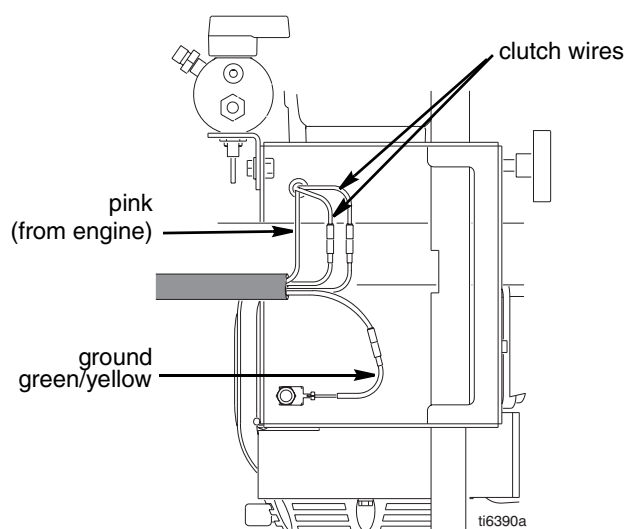

FIG. 12

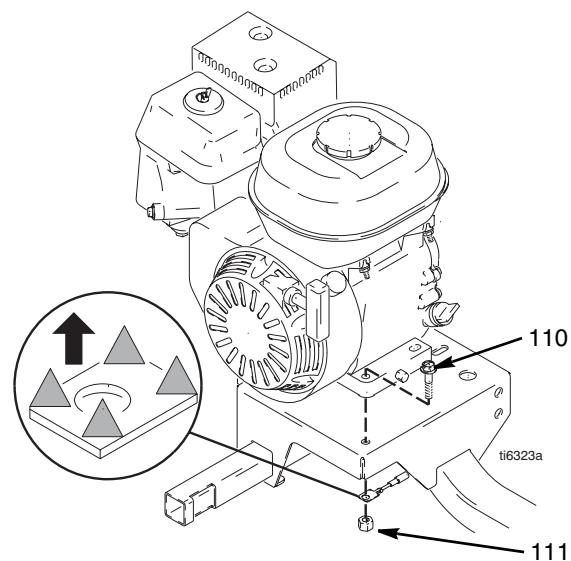

FIG. 13

Installation

1. Lift engine carefully and place on cart.
2. FIG. 13. Install two screws (110) in base of engine and secure with locknuts (111). Torque to 20 ft-lb (27.12 N·m).
3. FIG. 12. Connect all necessary wiring.
4. Install **Pinion Assembly/Clutch Armature/Clamp** and **Clutch Housing**, as instructed on pages 9 and 10 and 11.
5. Set engine to 3300 rpm.

Pressure Control

On/Off Switch

Removal

WARNING



Read Injection Hazard, page 3; Burn Hazard, page 4

1. Relieve pressure, page 5.
2. FIG. 14. Remove two screws (108) and open cover (62a).
3. Disconnect ON/OFF switch connector from PC board.
4. Press in on two retaining tabs on each side of ON/OFF switch (62d) and remove switch from cover.

Installation

1. Install new ON/OFF switch (62d) so tabs of switch snap into place on inside of cover.
2. Connect ON/OFF switch connector (B) to PC board.
3. Close cover (62a) and secure with two screws (108).

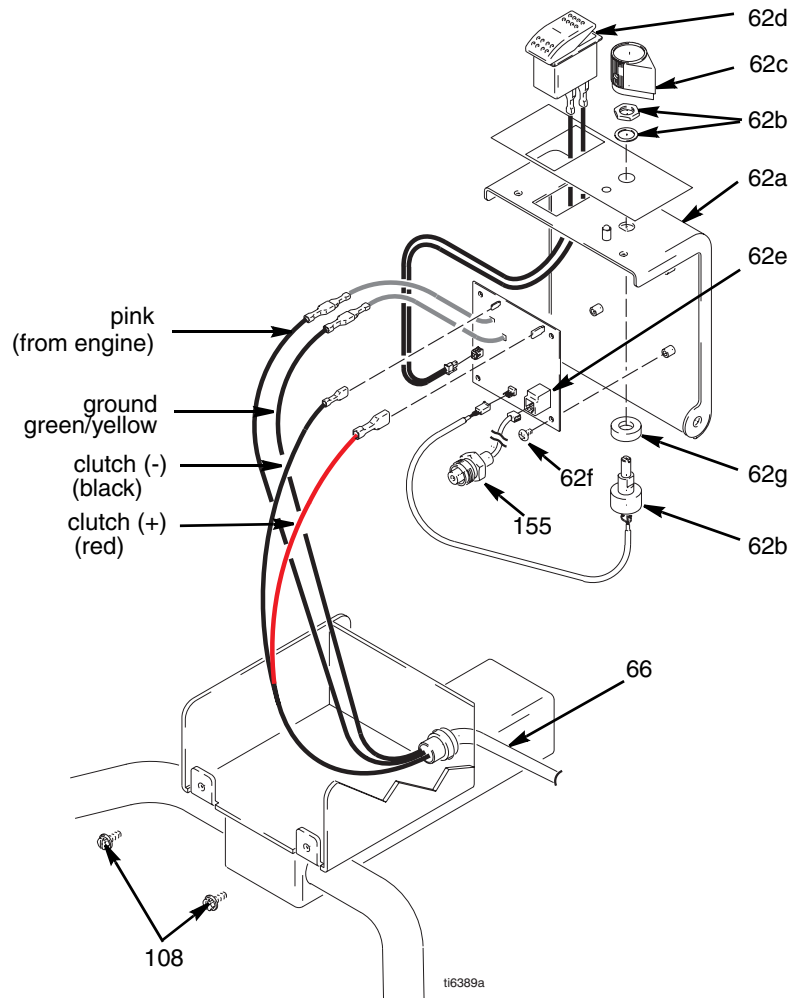

FIG. 14

Control Board

Removal



1. Relieve pressure, page 5.
2. FIG. 14. Remove two screws (108) and open cover (62a)
3. Disconnect engine and ground wires from wire harness (66).
4. Disconnect at control board (62e):
 - Lead from potentiometer (62b)
 - Lead from transducer (155)

- Lead from ON/OFF switch (62d)
 - Clutch wires
5. Remove four screws (62f) and control board (62e).

Installation

1. FIG. 14. Install control board (62e) with four screws (62f).
2. Connect at control board (62e):
 - Clutch wires
 - Lead from ON/OFF switch (62d)
 - Lead from transducer (155)
 - Lead from potentiometer (62b)
3. Connect engine and ground wires.
4. Close cover (62a) and secure with two screws (108).

Pressure Control Transducer

Removal

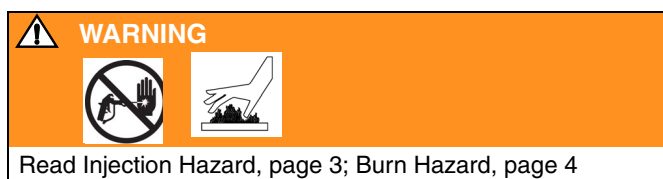

1. Relieve pressure, page 5.
2. FIG. 14. Remove two screws (108) and open cover (62a)
3. Disconnect transducer (155) lead from control board (62e).
4. Pull transducer connector through strain relief bushing (151).
5. Remove transducer and o-ring (99) from filter housing (67).

Installation

1. FIG. 14. Install o-ring (99) and transducer (155) in filter housing (67). Torque to 35 - 45 ft-lb.
2. Install transducer connector and strain relief bushing in control housing.
3. Connect lead (E) to control board (62e).
4. Close cover (62a) and secure with two screws (108).

Pressure Adjust Potentiometer

Removal



1. Relieve pressure, page 5.
2. Fig. 13. Remove two screws (108) and open cover (62a).
3. Disconnect potentiometer (62b) lead from control board (62e).
4. Loosen set screws on potentiometer knob (62c) and remove knob, shaft nut, lock washer and potentiometer (62b).
5. Remove spacer (62g) from potentiometer.

Installation

1. Install spacer (62g) on potentiometer (62b).
2. FIG. 14. Install potentiometer, shaft nut, lock washer and potentiometer knob (62c).
 - a. Turn potentiometer shaft clockwise to internal stop. Assemble potentiometer knob (62c) to strike pin on cover (62a).
 - b. After adjustment of step a., tighten both set screws in knob 1/4 to 3/8 turn after contact with shaft.
3. Connect potentiometer (62b) lead to control board (62e).
4. Close cover (62a) and secure with two screws (108).

Displacement Pump

Removal

1. Flush pump.

WARNING

Read Injection Hazard, page 3; Burn Hazard, page 4

2. Relieve pressure, page 5.
3. FIG. 16. Stop pump with piston rod (201) in its lowest position.
4. FIG. 15. Loosen two screws (32) and remove pump rod cover (107).

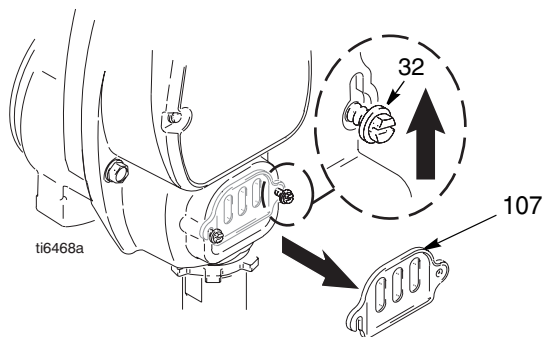

FIG. 15

5. FIG. 16. Remove hose (118) and suction hose (57). Use screwdriver; push retaining spring up; push out pin (31).

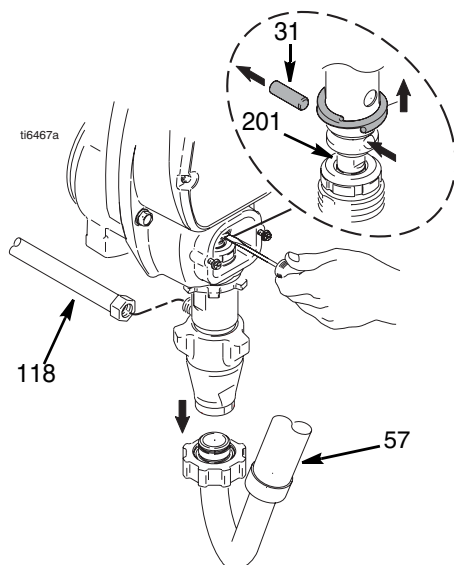

FIG. 16

6. FIG. 17. Loosen jam nut by hitting firmly with a hammer. Unscrew pump.

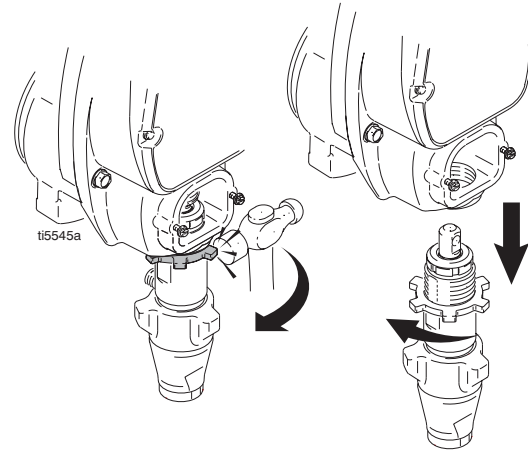

FIG. 17

Repair

See manual 309250 for pump repair instructions.

Installation

WARNING



If pin works loose, parts could break off and project through the air and result in serious injury or property damage. Make sure pin is properly installed.

CAUTION

If the pump jam nut loosens during operation, the threads of the bearing housing and drive train will be damaged. Tighten jam nut as specified.

1. Fig. FIG. 18. Pull piston rod out distance shown. Screw in pump until holes in connecting rod and piston rod align.

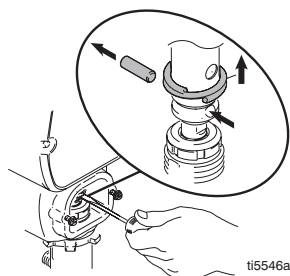

ti5546a

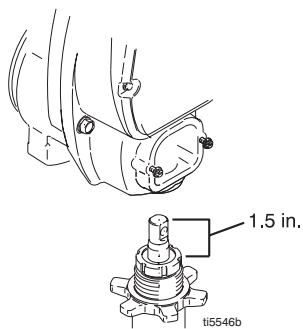

ti5546b

FIG. 18

2. FIG. 12. Push pin (31) into hole. Push retaining ring spring into groove all the way around connecting rod.
3. FIG. 19. Screw jam nut down onto pump until nut stops. Screw pump up into drive housing until top threads of pump are flush with drive housing face (FIG. 20). Back off pump and jam nut to align pump outlet to side. Tighten jam nut by hand, then tap 1/8 to 1/4 turn with a 20 oz (maximum) hammer to approximately 75 ±5 ft-lb (102 N·m). Connect hose (118) suction hose (57).

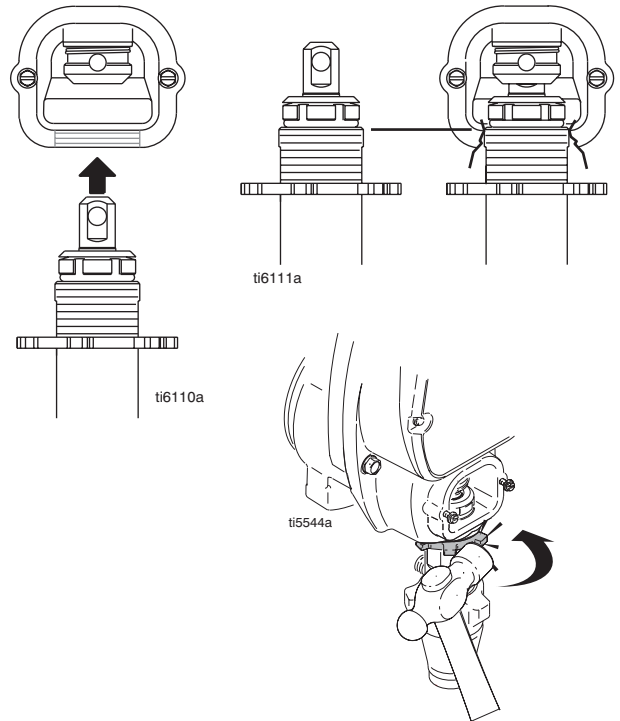
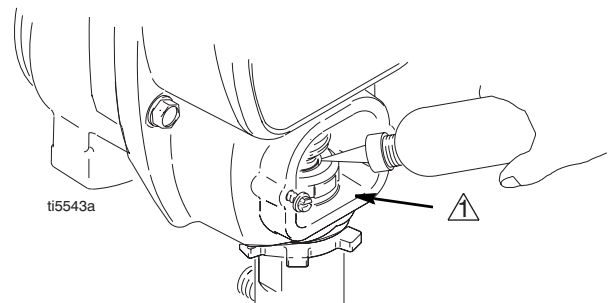

FIG. 19

4. FIG. 20. Fill packing nut with Graco TSL until fluid flows onto the top of seal. Install pump rod cover (107).



ti5543a

Drive housing face

FIG. 20

Parts

Parts Drawing - LineLazer 3400 Striper

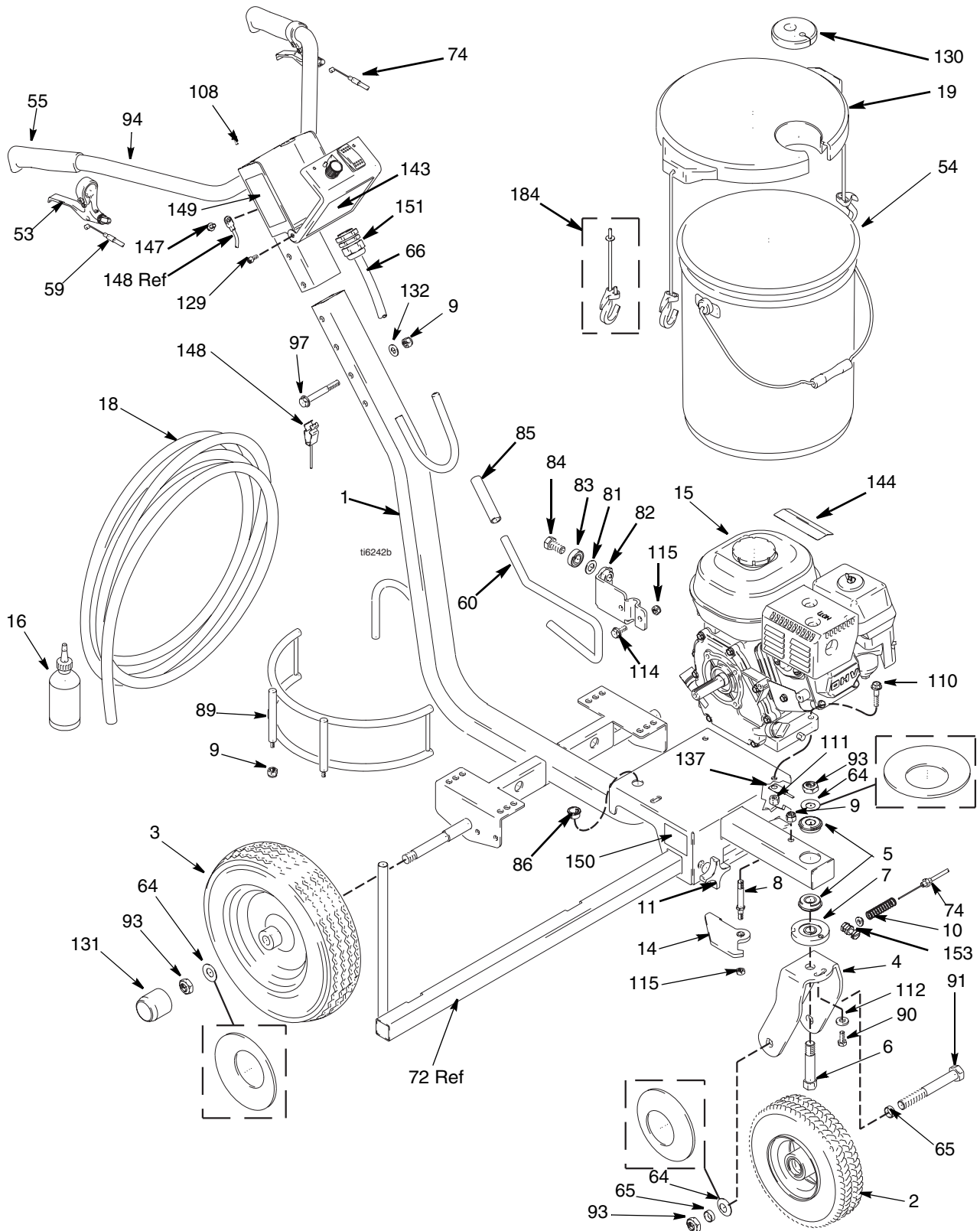

Parts List - LineLazer 3400 Striper

Ref. No.	Part No.	Description	Qty.	Ref. No.	Part No.	Description	Qty.
				84	113961	SCREW, cap, hex hd	1
				85	114808	CAP, vinyl	1
1	287630	FRAME, LL	1	86	119569	BUSHING, strain relief	1
2	119542	WHEEL, small	1	89	15E955	HOLDER, bucket	2
3	119543	WHEEL, large	2	90	100057	SCREW, cap, hex hd	1
4	15F127	FORK, painted	1	91	113665	SCREW, cap, hex hd	1
5	119532	BEARING, flanged	2	93	119554	NUT, lock, nylon, thin pattern	4
6	15E780	PIN, fork	1	94	248912	BAR, handle, LL	1
7	15E773	DISK, adjuster	1	97	116935	SCREW, cap, flnghd	2
8	15E792	PIN, lever	1	108	116719	SCREW, 8-32 hex washer head	2
9	101566	NUT, lock	7	110	110837	SCREW, flange, hex	2
10	114682	SPRING, compression	1	111	110838	NUT, lock	2
11	108471	KNOB, pronged	1	112	118866	WASHER, flat, extra thick	1
14	287682	LEVER, caster, includes 26	1	114	110963	SCREW, cap, flng hd	2
15	108879	ENGINE, gasoline, 4.0 hp	1	115	111040	NUT, lock, insert, nylock, 5/16 in.	3
16	206994	FLUID, TSL, 8 oz	1	129	101550	SCREW, cap, sch	2
18	249080	HOSE, coupled, 1/4 in. x 50 ft, nickel	1	130	15F514	GASKET, pail	1
19		KIT, pail cover		131	15C871	CAP, leg	2
	287590	Model 248861	1	132	100731	WASHER	2
	240926	Model 249007	1	137	119579	CONDUCTOR, ground	1
53	194310	LEVER, actuator	2	143	15F549	LABEL, identification	1
54	115077	PAIL, plastic	1	144▲	194126	LABEL, warning	1
55	116139	GRIP, handle	2	147	112798	SCREW, thread forming, hex hd	1
59	15E992	CABLE, gun	1	148	237686	WIRE, ground assembly w/ clamp	1
60	15E993	ROD, brake	1	149▲	15F638	LABEL, GMAX warning fire & skin	1
64	119563	WASHER, belleville	4	150▲	15F637	LABEL, GMAX warning skin inject	1
65	15E996	SPACER, wheel	2	151	15F928	BUSHING, strain relief	1
66	15E995	HARNESS, wiring, control	1	153	111025	GASKET, polypropylene (Wagner)	1
74	241445	CABLE, caster	1	184	119771	STRAP, cover (Model 249007)	1
81	195134	SPACER, ball, guide	1				
82	198891	BRACKET, mounting	1				
83	198931	BEARING	1				

▲ Replacement Danger and Warning labels, tags, and cards are available at no cost

Parts Drawing - LineLazer 3400 Striper

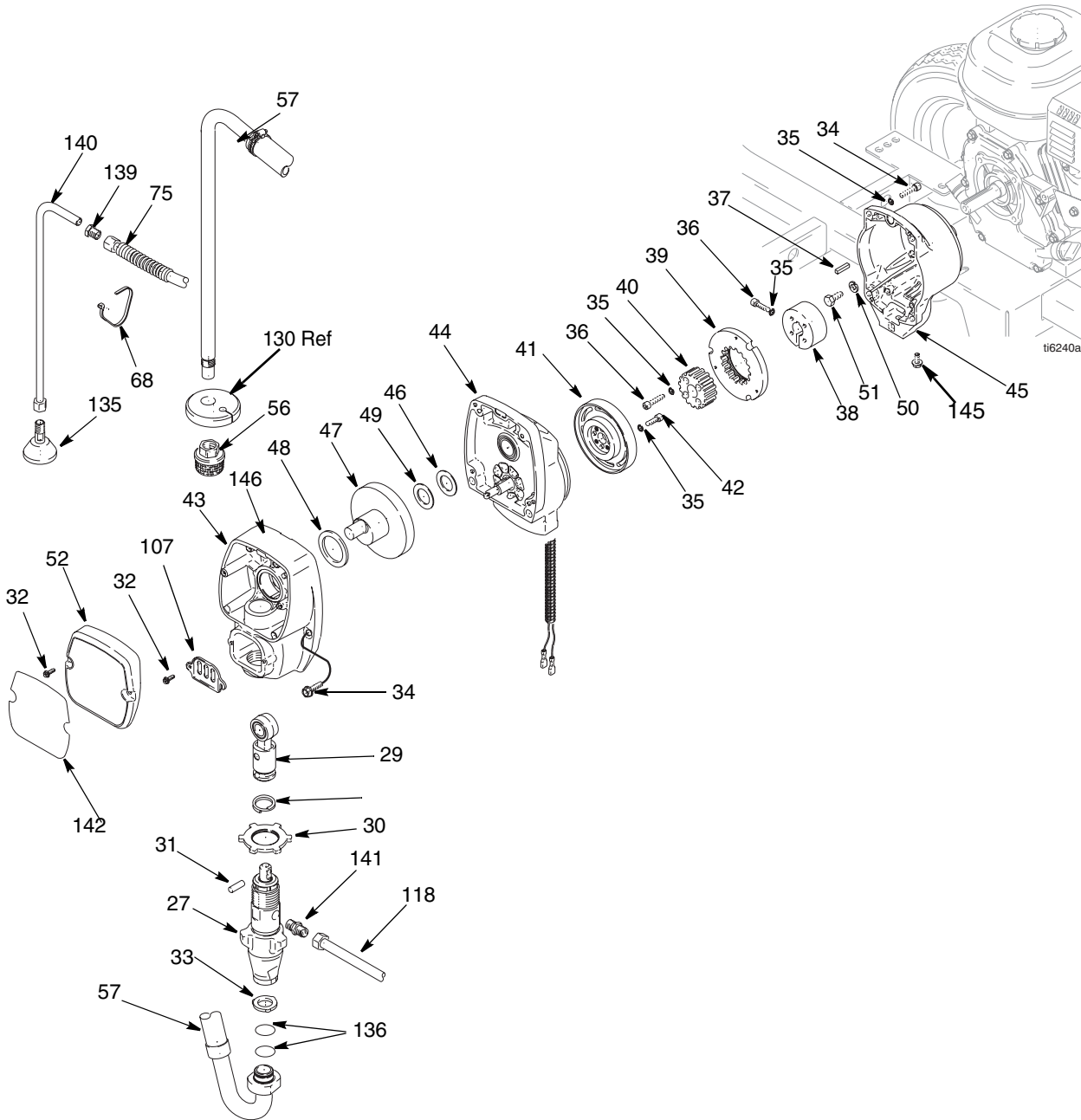

Parts List - LineLazer 3400 Striper

Ref No.	Part No.	Description	Qty	Ref No.	Part No.	Description	Qty
				49	107434	BEARING, thrust	1
				50	100214	WASHER, lock	4
27	246428	PUMP, displacement, st	1	51	108842	SCREW, cap, hex hd	4
29	287053	ROD, connecting	1	52	287487	COVER, front, painted, includes 32	1
30	195150	NUT, jam, pump	1	56	246385	STRAINER, 7/8-14 unf	1
31	196762	PIN, straight	1	57	287683	HOSE, suction, includes 33, 56, 130, 136	1
32	117501	SCREW, mach, hex washer head	4	68	114958	STRAP, tie	5
33†	115099	WASHER, garden hose	1	75	249232	HOSE, cpld, 1/4 in. X 3 ft	1
34	119426	SCREW, mach, hex washer hd	8	107	15B589	COVER, pump rod	1
35*	105510	WASHER, lock, spring (hi-collar)	10	118	249149	HOSE, coupled, 1/4 X 22.25 in.	1
36*	108803	SCREW, hex, socket head	6	135	241920	DEFLECTOR, threaded	1
37	183401	KEY, parallel	1	136†	117559	O-RING	2
38	193680	COLLAR, shaft	1	139	196180	BUSHING	1
39*		ARMATURE, clutch, 4 in.	1	140	198601	TUBE, drain	1
40*		HUB, armature	1	141	196181	FITTING, nipple	2
41*		ROTOR, clutch, 4 in.	1	142	15F538	LABEL, identification	1
42*	101682	SCREW, cap, sch	4	145	112395	SCREW, cap, flnghd	1
43	287483	HOUSING, drive, 3400, includes 32, 34	1	146	290228	LABEL, caution	1
44	287376	HOUSING, pinion, 3400	1				
45	15E535	HOUSING, clutch, machine, 3400	1				
46	116074	WASHER, thrust	1				
47	287484	CRANK, GMAX 3000, includes 46, 48, 49	1				
48	180131	BEARING, thrust	1				

▲ Replacement Danger and Warning labels, tags, and cards are available at no cost

* Included in Clutch Replacement Kit 241109

† Included in Suction Hose Kit 249356

Parts Drawing and List - Pinion Housing

Ref No. 44: Pinion Housing

No.	Part No.	Description	Qty
44	287376	PINION HOUSING	1
44a	287482	KIT, repair, coil	1
44b	105489	PIN	2
44c*	287485	PINION SHAFT	1
44d*	113094	RETAINING RING, large	1

* Must be ordered separately

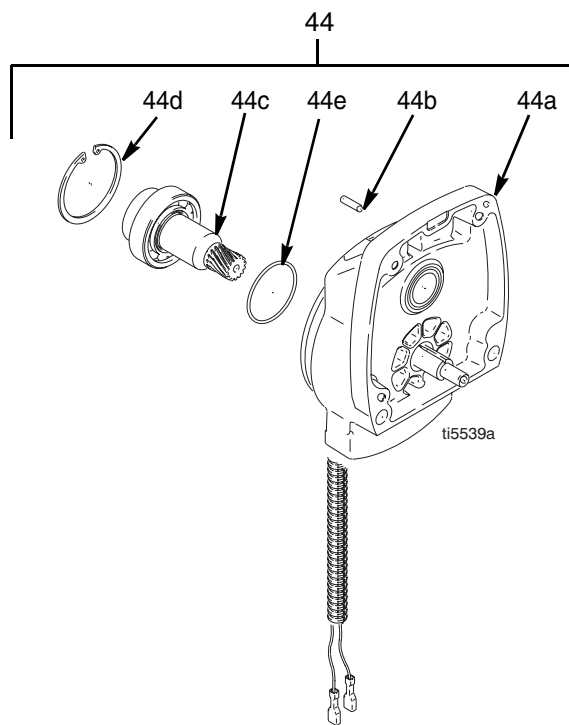

Gun Arm Parts

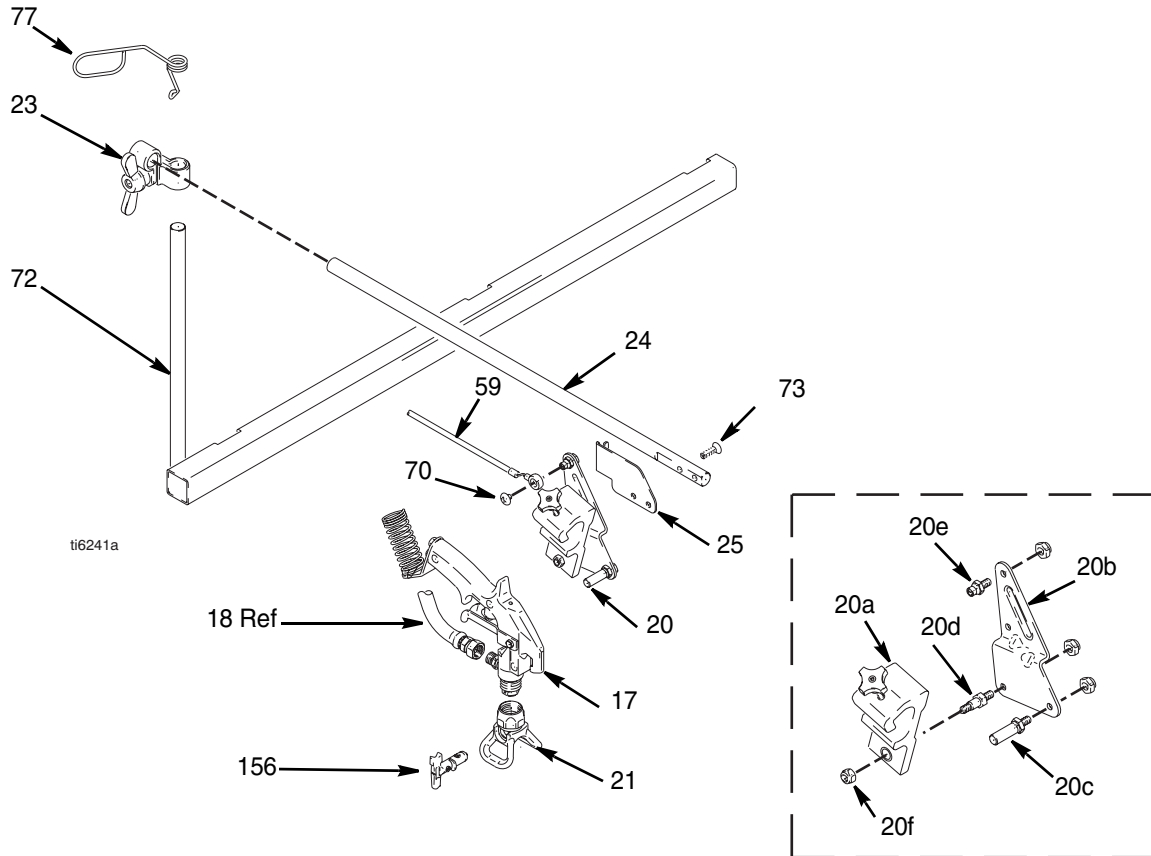

LineLazer IV 3400 Striper

Ref	Part	Description	Qty	Ref	Part	Description	Qty
				23	287566	KIT, clamp	1
				24	15F212	ARM, holder, gun	1
17	248157	GUN, Flex, basic	1	25	15F213	BRACKET, cable	1
20	287570	HOLDER, gun	1	59	15E992	CABLE, gun	1
20a	287569	HOLDER, gun	1	70	119648	SCREW, mach, trusshd, cross recess	1
20b	15F214	LEVER, actuator	1	72	224052	BRACKET, support gun	1
20c	15F209	STUD, pull trigger	1	73	119647	SCREW, cap, socket, flthd	2
20d	15F210	STUD, pivot	1	77	188135	GUIDE, cable	1
20e	15F211	STUD, cable	1	156	LL5319	TIP, spray, striping	1
20f	102040	NUT, lock	4				
21	243161	GUARD, RAC 5	1				

Pressure Control/Filter Assembly

LineLazer IV 3400 Striper

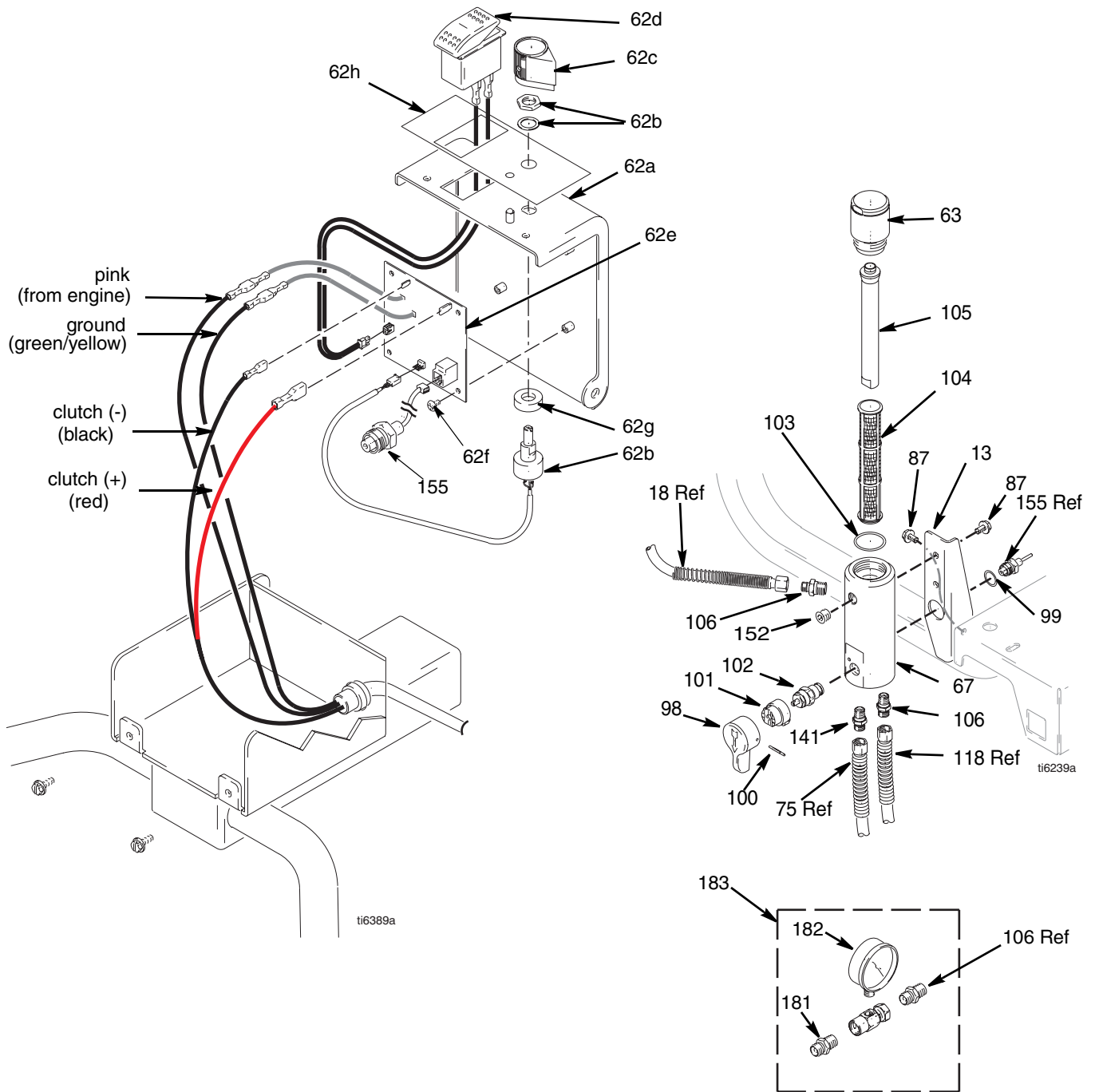

Pressure Control/Filter Assembly

LineLazer IV 3400 Striper

Ref	Part	Description	Qty	Ref	Part	Description	Qty
				100*	15C972	PIN, grooved	1
				101*	224807	BASE, valve	1
13	15E748	BRACKET, manifold	1	102*	239914	VALVE, drain	1
62		CONTROL, assy		103*	104361	O-RING	1
62a	15E991	COVER, control box	1	104*	244067	FILTER, fluid	1
62b	241443	POTENTIOMETER	1	105*	15C766	TUBE, diffusion	1
62c	116167	KNOB, potentiometer	1	106	196177	ADAPTER, nipple	2
62d	116752	SWITCH, rocker	1	141	196181	FITTING, nipple	1
62e	287486	BOARD, control, 3400	1	152*	101748	PIPE, plug, sst	1
62f	113045	SCREW, sems, mach, phillips, truss	4	155*	15F782	HARNESSE, transducer, line striper	1
62g	198650	SPACER, shaft	1	181	196178	NIPPLE, 3/8 x 3/8 in.	1
62h	15F540	LABEL, instructions	1	182	102814	GAUGE, pressure fluid	1
63*	15E998	CAP, manifold	1	183	241339	KIT, gauge, 3/8 in., includes 181, 182	1
67*	15E997	MANIFOLD, filter	1				
87	111801	SCREW, cap, hex hd	4				
98*	15C780	HANDLE	1				
99*	111457	O-RING	1				

* Included in Filter Repair Kit 287685

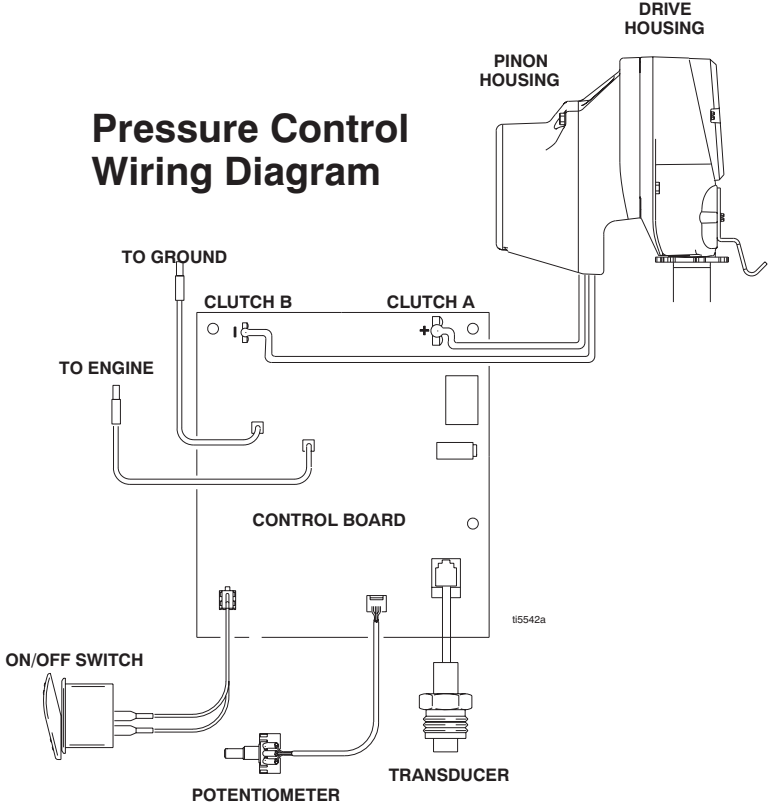

Technical Data

Honda GX120 Engine	
ANSI Power Rating @ 3600 rpm	4.0 Horsepower (2.9 kW)
Maximum working pressure	3300 psi (227 bar, 22.7 MPa)
Noise Level	
Sound power	100 dBa per ISO 3744
Sound pressure	86 dBa measured at 3.1 feet (1 m)
Vibration Level	
* Left hand	3.89 m/sec ²
* Right hand	4.94 m/sec ²
*Vibration measured per ISO 5349 Based on 8 hr daily exposure	
Maximum delivery rating	0.75 gpm (2.84 liter/min)
Maximum tip size	1 gun with 0.027 in. tip
Inlet paint strainer	12 mesh (893 micron) stainless steel screen, reusable
Outlet paint filter	60 mesh (250 micron) stainless steel screen, reusable
Pump inlet size	1¼-12 unf-2b
Fluid outlet size	¼ npsm from fluid filter
Wetted parts	PTFE, Nylon, polyurethane, UHMW polyethylene, Viton [®] , Delrin [®] , leather, tungsten carbide, nickel-plated carbon steel, stainless steel, chrome plating
NOTE: Delrin [®] , Viton [®] are trademarks of the DuPont Company.	

Dimensions

Sprayer	Weight lb (kg)	Height in. (cm)	Width in. (cm)	Length in. (cm)
248861	150 (68)	40.5 (103)	32 (81)	61.5 (156)
249007	150 (68)	40.5 (103)	32 (81)	61.5 (156)

Graco Standard Warranty

Graco warrants all equipment referenced in this document which is manufactured by Graco and bearing its name to be free from defects in material and workmanship on the date of sale to the original purchaser for use. With the exception of any special, extended, or limited warranty published by Graco, Graco will, for a period of twelve months from the date of sale, repair or replace any part of the equipment determined by Graco to be defective. This warranty applies only when the equipment is installed, operated and maintained in accordance with Graco's written recommendations.

This warranty does not cover, and Graco shall not be liable for general wear and tear, or any malfunction, damage or wear caused by faulty installation, misapplication, abrasion, corrosion, inadequate or improper maintenance, negligence, accident, tampering, or substitution of non-Graco component parts. Nor shall Graco be liable for malfunction, damage or wear caused by the incompatibility of Graco equipment with structures, accessories, equipment or materials not supplied by Graco, or the improper design, manufacture, installation, operation or maintenance of structures, accessories, equipment or materials not supplied by Graco.

This warranty is conditioned upon the prepaid return of the equipment claimed to be defective to an authorized Graco distributor for verification of the claimed defect. If the claimed defect is verified, Graco will repair or replace free of charge any defective parts. The equipment will be returned to the original purchaser transportation prepaid. If inspection of the equipment does not disclose any defect in material or workmanship, repairs will be made at a reasonable charge, which charges may include the costs of parts, labor, and transportation.

Graco's sole obligation and buyer's sole remedy for any breach of warranty shall be as set forth above. The buyer agrees that no other remedy (including, but not limited to, incidental or consequential damages for lost profits, lost sales, injury to person or property, or any other incidental or consequential loss) shall be available. Any action for breach of warranty must be brought within two (2) years of the date of sale.

GRACO MAKES NO WARRANTY, AND DISCLAIMS ALL IMPLIED WARRANTIES OF MERCHANTABILITY AND FITNESS FOR A PARTICULAR PURPOSE, IN CONNECTION WITH ACCESSORIES, EQUIPMENT, MATERIALS OR COMPONENTS SOLD BUT NOT MANUFACTURED BY GRACO. These items sold, but not manufactured by Graco (such as electric motors, switches, hose, etc.), are subject to the warranty, if any, of their manufacturer. Graco will provide purchaser with reasonable assistance in making any claim for breach of these warranties.

In no event will Graco be liable for indirect, incidental, special or consequential damages resulting from Graco supplying equipment hereunder, or the furnishing, performance, or use of any products or other goods sold hereto, whether due to a breach of contract, breach of warranty, the negligence of Graco, or otherwise.

FOR GRACO CANADA CUSTOMERS

The Parties acknowledge that they have required that the present document, as well as all documents, notices and legal proceedings entered into, given or instituted pursuant hereto or relating directly or indirectly hereto, be drawn up in English. Les parties reconnaissent avoir convenu que la rédaction du présente document sera en Anglais, ainsi que tous documents, avis et procédures judiciaires exécutés, donnés ou intentés, à la suite de ou en rapport, directement ou indirectement, avec les procédures concernées.

ADDITIONAL WARRANTY COVERAGE

Graco does provide extended warranty and wear warranty for products described in the Graco Contractor Equipment Warranty Program.

TO PLACE AN ORDER, contact your Graco distributor, or call **1-800-690-2894** to identify the nearest distributor.

All written and visual data contained in this document reflects the latest product information available at the time of publication.
Graco reserves the right to make changes at any time without notice.

Graco Headquarters: Minneapolis

International Offices: Belgium, Korea, China, Japan

GRACO INC. P.O. BOX 1441 MINNEAPOLIS, MN 55440-1441

<http://www.graco.com>

PRINTED IN U.S.A. 3/2005, Revised 10/2005