

Repair Instructions



GMax[®] 7900

309412F

Airless Paint Sprayer

3300 *psi* (227bar, 22.7 MPa) *Maximum Working Pressure*

See page 2 for models numbers.



Important Safety Instructions

Read all warnings and instructions in this manual.
Save these instructions.

Related Manuals

| | |
|------------------------------|--------|
| Operation | 309408 |
| Displacement Pump | 309277 |
| Spray Gun | 309639 |
| Spray Tip | 309640 |
| PC Board | 309459 |
| Drain Valve Kit | 308961 |
| Clutch Replacement Kit | 309890 |

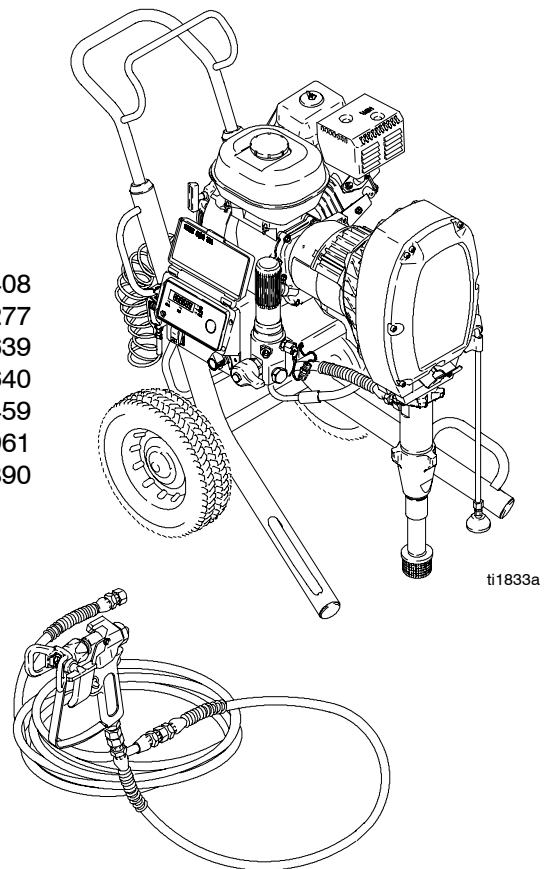

PROVEN QUALITY. LEADING TECHNOLOGY.



Models

| Model | Series | Description |
|--------|--------|--|
| 233718 | A | Lo-Boy |
| 233719 | A | Hi-Boy |
| 233720 | A | Lo-Boy with RAC [®] X tip, gun and hose |
| 233721 | A | Hi-Boy with RAC X tip, gun and hose |

Table of Contents

| | | | |
|-----------------------------|----|--------------------------|----|
| Warnings and Cautions | 3 | Parts | |
| Maintenance | 4 | Pinion Assembly | 17 |
| Troubleshooting | 5 | Sprayers | 18 |
| Repair | | Pressure Control | 21 |
| Rollers | 8 | Tip, Gun, Hose | 22 |
| Drive Housing | 9 | Dimensions | 23 |
| Cam Follower Bearings | 10 | Technical Data | 23 |
| Engine | 11 | Graco Warranty | 24 |
| Pressure Control | 13 | Graco Phone Number | 24 |
| Displacement Pump | 15 | | |

Warnings and Cautions

Warning Symbol









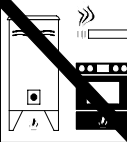

This symbol alerts you to the possibility of serious injury or death if you do not follow the instructions.

Caution Symbol

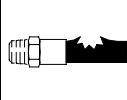

This symbol alerts you to the possibility of damage to or destruction of equipment if you do not follow the instructions.

| | |
|--|---|
|  WARNING |  |
| <p>Fire and explosion: Solvent and paint fumes can ignite or explode.</p> <p>To help prevent a fire and explosion:</p> <ul style="list-style-type: none"> ● Use only in an extremely well ventilated area. ● Eliminate all ignition sources; such as pilot lights, cigarettes and plastic drop cloths (static arc hazard). Do not plug or unplug power cords or turn lights on or off in spray area. ● Ground Sprayer, object being sprayed, paint and solvent pails. ● Hold gun firmly to side of grounded pail when triggering into pail. ● Use only conductive airless paint hose. ● Do not use 1,1,1-trichloroethane, methylene chloride, other halogenated hydrocarbon solvents or fluids containing such solvents in pressurized aluminum equipment. Such use could result in a chemical reaction, with the possibility of explosion. ● Do not fill fuel tank while engine is running or hot. ● Do not flush with gasoline. |  |
| <p>Fluid injection and high pressure hazard: High pressure spray or leaks can inject fluid into the body.</p> <p>To help prevent injection, always:</p> <ul style="list-style-type: none"> ● Engage trigger safety latch when not spraying. ● Keep clear of nozzle and leaks. ● Never spray without a tip guard. ● Do PRESSURE RELIEF if you stop spraying or begin servicing sprayer. ● Do not use components rated less than sprayer <i>Maximum Working Pressure</i>. ● Never allow children to use this unit. <p>If high pressure fluid pierces your skin, the injury might look like "just a cut", but it is a serious wound! Get immediate medical attention.</p> |  |
| |  |
| |  |
| |  |
| |  |
| |  |

Maintenance

WARNING

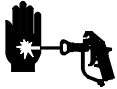

INJECTION HAZARD

The system pressure must be manually relieved to prevent the system from starting or spraying accidentally. Fluid under high pressure can be injected through the skin and cause serious injury. To reduce the risk of an injury from injection, splashing fluid, or moving parts, follow the **Pressure Relief Procedure** whenever you:

- are instructed to relieve the pressure,
- stop spraying,
- check or service any of the system equipment,
- or install or clean the spray tip.

Pressure Relief Procedure

1. Lock gun trigger safety.
2. Turn engine ON/OFF switch to OFF.
3. Move pressure control switch to OFF and turn pressure control knob fully counterclockwise.
4. Unlock trigger safety. Hold metal part of gun firmly to side of grounded metal pail, and trigger gun to relieve pressure.
5. Lock gun trigger safety.
6. Open pressure drain valve. Leave valve open until ready to spray again.

If you suspect that the spray tip or hose is completely clogged, or that pressure has not been fully relieved after following the steps above, VERY SLOWLY loosen tip guard retaining nut or hose end coupling to relieve pressure gradually, then loosen completely. Now clear tip or hose.

CAUTION

For detailed engine maintenance and specifications, refer to separate Honda Engines Owner's Manual, supplied.

DAILY: Check engine oil level and fill as necessary.

DAILY: Check hose for wear and damage.

DAILY: Check gun safety for proper operation.

DAILY: Check pressure drain valve for proper operation.

DAILY: Check and fill the gas tank.

AFTER THE FIRST 20 HOURS OF OPERATION:

Drain engine oil and refill with clean oil. Reference Honda Engines Owner's Manual for correct oil viscosity.

WEEKLY: Remove air filter cover and clean element. Replace element, if necessary. If operating in an unusually dusty environment: check filter daily and replace, if necessary.

Replacement elements can be purchased from your local HONDA dealer.

WEEKLY: Check level of TSL in displacement pump packing nut. Fill nut, if necessary. Keep TSL in nut to help prevent fluid buildup on piston rod and premature wear of packings.

AFTER EACH 100 HOURS OF OPERATION:

Change engine oil. Reference Honda Engines Owner's Manual for correct oil viscosity.

SPARK PLUG: Use only BPR6ES (NGK) or W20EPR-U (NIPPONDENSO) plug. Gap plug to 0.028 to 0.031 in. (0.7 to 0.8 mm). Use spark plug wrench when installing and removing plug.

Troubleshooting



Relieve pressure; page 4.

| PROBLEM | CAUSE | SOLUTION |
|--|--|---|
| E=XX is displayed | Fault condition exists | Determine fault correction from table, page 14. |
| Engine won't start | Engine switch is OFF | Turn engine switch ON |
| | Engine is out of gas | Refill gas tank. Honda Engines Owner's Manual. |
| | Engine oil level is low | Try to start engine. Replenish oil, if necessary. Honda Engines Owner's Manual. |
| | Spark plug cable is disconnected or damaged | Connect spark plug cable or replace spark plug |
| | Cold engine | Use choke |
| | Fuel shutoff lever is OFF | Move lever to ON position |
| | Oil is seeping into combustion chamber | Remove spark plug. Pull starter 3 to 4 times. Clean or replace spark plug. Start engine. Keep sprayer upright to avoid oil seepage. |
| False tripping of WatchDog system. EMPTY is displayed. Pump does not run. | Operating conditions out of WatchDog parameters | Turn pressure down. Contact Graco Technical Assistance to adjust WatchDog parameters. Operate without WatchDog active; Manual 309408. |
| | Low pump output. | See Troubleshooting Table, Pump Outlet Low, page 6. |
| Engine operates, but displacement pump does not operate | Error code displayed? | Determine fault correction from table, page 14. |
| | Pump switch is OFF | Turn pump switch ON. |
| | Pressure setting is too low | Turn pressure adjusting knob clockwise to increase pressure. |
| | Fluid filter (318) is dirty | Clean filter. Page 20. |
| | Tip or tip filter is clogged | Clean tip or tip filter. Manual 309091. |
| | Displacement pump piston rod is stuck due to dried paint | Repair pump. Manual 309277. |
| | Connecting rod is worn or damaged | Replace connecting rod. Page 15. |
| | Drive housing is worn or damaged | Replace drive housing. Page 9. |
| | Electrical power is not energizing clutch field | Check wiring connections. Page 11. Reference pressure control repair. Page 13. Reference wiring diagram. Page 21. With pump switch ON and pressure turned to MAXIMUM, use a test light to check for power between clutch test points on control board. Remove 7-pin connector from control board and measure resistance across clutch coil. At 70° F, the resistance must be between 1.7 ±0.2Ω ; if not, replace pinion housing. Have pressure control checked by authorized Graco dealer. |

Troubleshooting

| PROBLEM | CAUSE | SOLUTION |
|---|---|--|
| | Clutch is worn, damaged, or incorrectly positioned | Replace clutch. Manual 309890. |
| | Pinion assembly is worn or damaged | Repair or replace pinion assembly. Manual 309890. |
| Pump output is low. | Strainer (89) is clogged | Clean strainer. Sprayer 233716 strainer is for use in paint only. |
| | Piston ball (206) is not seating | Service piston ball. Manual 309277. |
| | Piston packings are worn or damaged | Replace packings. Manual 309277. |
| | O-ring (227) in displacement pump is worn or damaged | Replace o-ring. Manual 309277. |
| | Intake valve ball is not seating properly | Clean intake valve. Manual 309277. |
| | Intake valve ball is packed with material | Clean intake valve. Manual 309277. Do not leave 233716 sprayer under pressure for more than 5 minutes when spraying texture and not actively spraying. |
| | Engine speed is too low | Increase throttle setting. Manual 309408. |
| | Clutch is worn or damaged | Replace clutch. Manual 309890. |
| | Pressure setting is too low | Increase pressure. Manual 309408. |
| | Fluid filter (318), tip filter or tip is clogged or dirty | Clean filter. Manual 309408 or 309091. |
| | Large pressure drop in hose with heavy materials | Use larger diameter hose and/or reduce overall length of hose. Use of more than 100 ft of 1/4 in. hose significantly reduces performance of sprayer. Use 3/8 in. hose for optimum performance (50 ft minimum). |
| Excessive paint leakage into throat packing nut | Throat packing nut is loose | Remove throat packing nut spacer. Tighten throat packing nut just enough to stop leakage. |
| | Throat packings are worn or damaged | Replace packings. Manual 309277. |
| | Displacement rod is worn or damaged | Replace rod. Manual 309277. |
| Fluid is spitting from gun | Air in pump or hose | Check and tighten all fluid connections. Re-prime pump. Manual 309408. |
| | Tip is partially clogged | Clear tip. Manual 309091. |
| | Fluid supply is low or empty | Refill fluid supply. Prime pump. Manual 309408. Check fluid supply often to prevent running pump dry. |
| Pump is difficult to prime | Air in pump or hose | Check and tighten all fluid connections. Reduce engine speed and cycle pump as slowly as possible during priming. |
| | Intake valve is leaking | Clean intake valve. Be sure ball seat is not nicked or worn and that ball seats well. Reassemble valve. |
| | Pump packings are worn | Replace pump packings. Manual 309277. |
| | Paint is too thick | Thin the paint according to the supplier's recommendations |

Troubleshooting

| PROBLEM | CAUSE | SOLUTION |
|---|--|--|
| | Engine speed is too high | Decrease throttle setting before priming pump. Manual 309408. |
| Clutch squeaks each time clutch engages | Clutch surfaces are not matched to each other when new and may cause noise | Clutch surfaces need to wear into each other. Noise will dissipate after a day of run time. |
| High engine speed at no load | Misadjusted throttle setting | Reset throttle to 3700 engine rpm at no load |
| | Worn engine governor | Replace or service engine governor |
| Gallon counter not working | Bad sensor, broken or disconnected wire | Check connections. Replace sensor or wire. |
| No display, sprayer operates | Display damaged or has bad connection | Check connections. Replace display. |
| Clutch squeaks each time clutch engages | Clutch surfaces are not matched to each other when new and may cause noise | Clutch surfaces need to wear into each other. Noise will dissipate after a day of run time |
| Engine stalls | Engine speed is too slow | <ul style="list-style-type: none"> • Increase throttle setting • Adjust engine speed at no load to 3750 - 3850 rpm |
| | Fluid filter is clogged | Relieve pressure and clean filter |
| | Too much pump friction (new pump) | Reduce pressure to 3000 psi until pump wears in |
| | Spark plug wire is loose | Reconnect wire |

Rollers

Removal

1.  Relieve pressure; page 4.
2. Fig. 1. Remove six cap screws (56) lock washers (87), clip (35), and cover assembly (13).

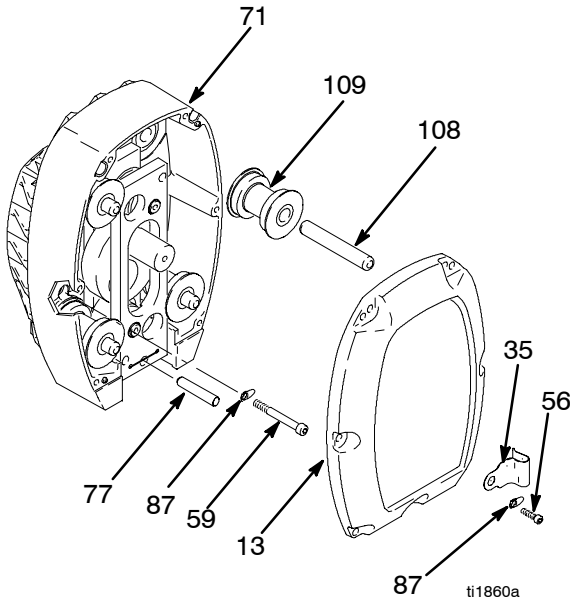

Fig. 1

Note: A screw driver may be needed to pry off cover assembly.

3. Remove dowel pins (108) and rollers (109)

Installation

1. Install rollers (109) and dowel pins (108)
2. Install cover assembly (13) with six lock washers (87), clip (35), and cap screws (56).

Drive Housing

Removal

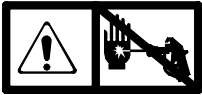
- 
 Relieve pressure; page 4.
- Fig. 2. Disconnect gallon counting sensor.

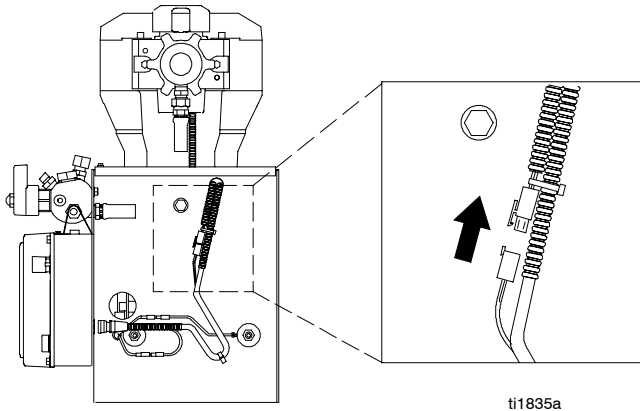
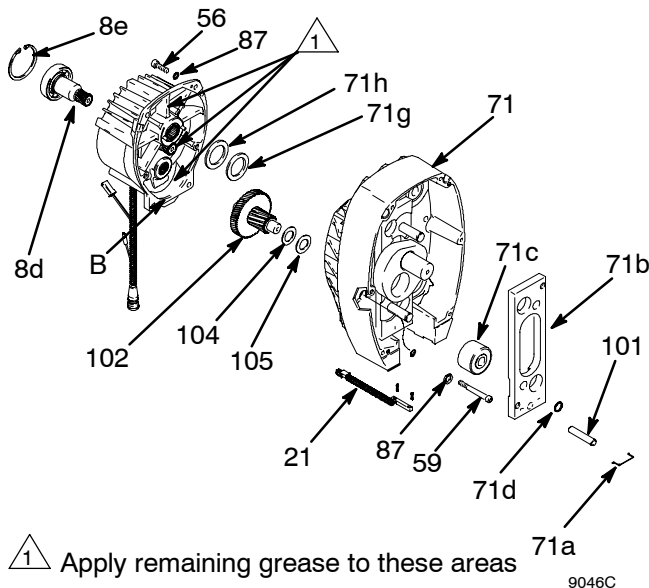



Fig. 2

- Fig. 1. Remove six cap screws (56) lock washers (87) and cover assembly (13).
- Fig. 3. Remove two screws (59) and washers (87).
- Remove four cap screws (56) lock washers (87) from drive housing (71).
- Lightly tap around drive housing (71) to loosen drive housing. Pull drive housing straight off pinion housing. Be prepared to support gear cluster (102), which may also come out.



 Apply remaining grease to these areas
Fig. 3

Installation

- Liberaly apply bearing grease (supplied with replacement gear cluster) to gear cluster (102), washers (104) and (105) and to areas called out by note 1. Use full 0.68 pint (0.32 liter) of grease for GMax 7900.
- Place bronze colored washer (105) and silver colored washer (104) onto drive housing (71). Install gear cluster (102) through washers (105) and (104).
- Place bronze colored washer (71g) and silver colored washer (71h) on shaft protruding from large shaft of drive housing (71). Align gears and push new drive housing straight onto pinion housing and locating pins (B).
- Install two washers (87) and screws (59).
- Install four lock washers (87) and cap screws (56) into drive housing (71).
- Install cover assembly (13) with six lock washers (87) and cap screws (56).
- Fig. 4. Reconnect gallon counting sensor.

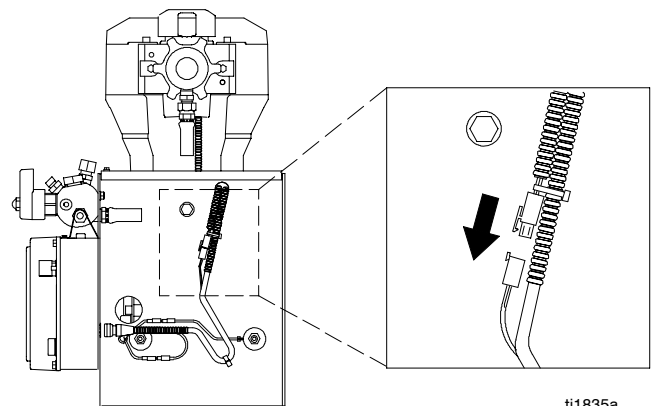



Fig. 4

Cam Follower Bearings

Removal

1.  Relieve pressure; page 4.
2. Fig. 9. Cycle pump piston rod (222) to lowest position. Turn engine off.
3. Fig. 5. Remove six cap screws (56), lock washers (87) and cover assembly (13).

Note: A screw driver may be needed to pry off cover assembly.

4. Remove four dowel pins (108) and rollers (109).
5. From front, drive out pump pin (77) with a screw driver.
6. Remove two retainer rings (71d).
7. Remove cam follower plate (71b).

Note: Two 1/2 in. x 13 bolts may be needed to remove cam follower plates.

8. Remove two cam follower bearings (71c).

Installation

1. Install two cam follower bearings (71c).
2. Install cam follower plate (71b).
3. Install two retainer rings (71d).
4. Drive in pump pin (77) until it engages with pump pin retaining clip (71a).
5. Install four rollers (109) and dowel pins (108).
6. Install cover assembly (13) with six lock washers (87) and cap screws (56).

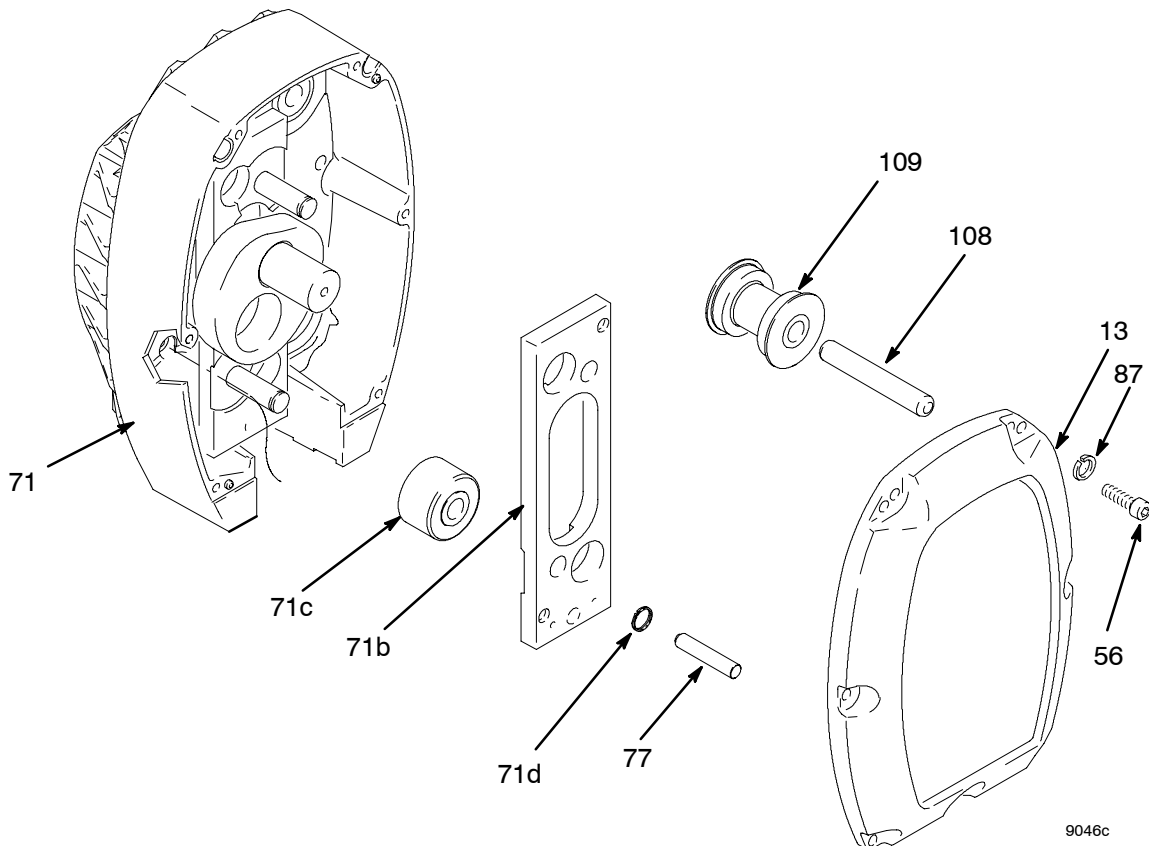

Fig. 5

9046c

Engine

Removal

1. Remove **Pinion Assembly/Rotor/Field/Pinion/Clutch, Clamp** and **Clutch Housing**, as instructed in manual 309890.
2. Fig. 6. Disconnect all necessary wiring.
3. Fig. 7. Remove two locknuts (7) and screws (6) from base of engine.
4. Lift engine carefully and place on work bench.

NOTE: All service to the engine must be performed by an authorized HONDA dealer.

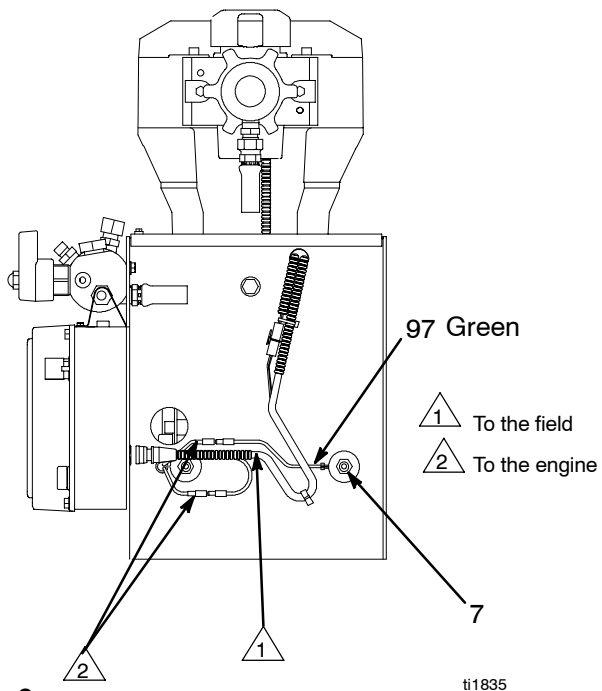

Fig. 6

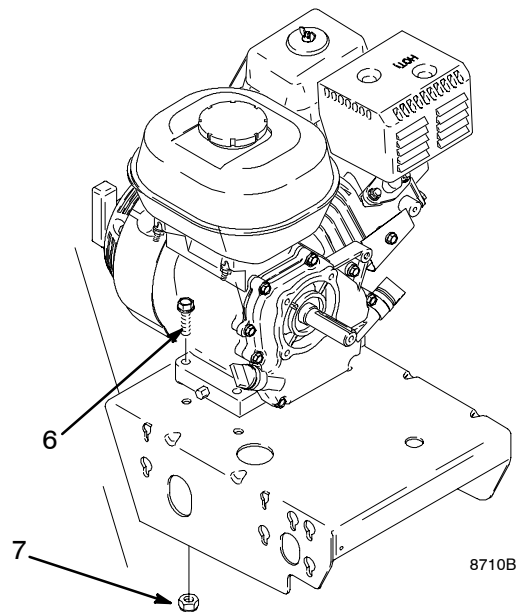



Fig. 7

Installation

1. Lift engine carefully and place on cart.
2. Fig. 7. Install two screws (6) in base of engine and secure with locknuts (7). Torque to 200 in-lb (22.6 N•m).
3. Fig. 6. Connect all necessary wiring.
4. Install **Pinion Assembly/Rotor/Field/Pinion/Clutch, Clamp** and **Clutch Housing**, as instructed in manual 309890.

On/Off Switch

Removal

1.  Relieve pressure; page 4.
2. Fig. 8. Remove four screws (54) and display/cover (52).
3. Pull display connector wings (A) open on PC board and pull display connector out.
4. Disconnect ON/OFF switch connector (B) from PC board.
5. Press in on two retaining tabs on each side of ON/OFF switch (51) and remove switch.

Installation

1. Install new ON/OFF switch (51) so tabs of switch snap into place on inside of pressure control housing.
2. Connect ON/OFF switch connector (B) to PC board.
3. Push display connector into PC board close display connector wings (A) on PC board.
4. Install display/cover (52) with four screws (54).

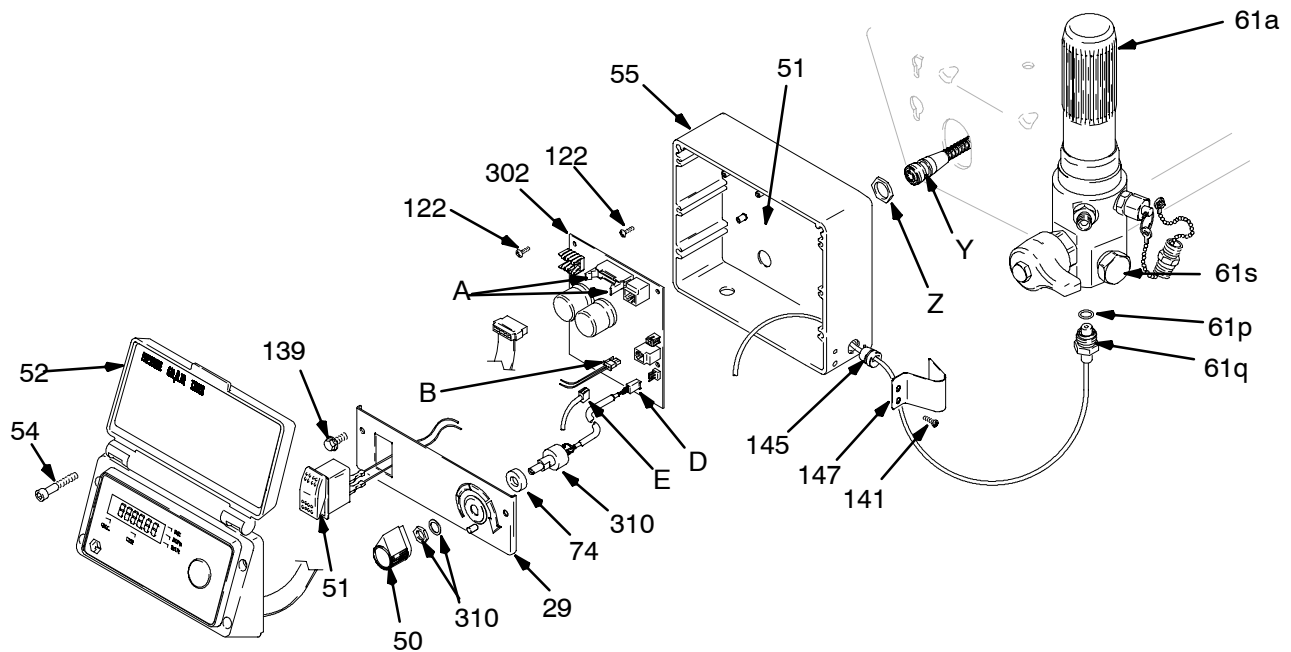



Fig. 8

ti1841a

Pressure Control

Control Board

Removal

-  1. Relieve pressure; page 4.
2. Fig.8. Remove four screws (54) and display/cover (52). Pull display connector wings (A) open on PC board and pull display connector out.
3. Remove 2 screws (139).
4. Fig. 15. Disconnect at control board (302):
 - Lead (D) from potentiometer.
 - Lead (E) from transducer.
 - Lead (B) from On/Off Switch connector.
5. Fig. 8. Remove five screws (122) from control board and ground wire screw (122).
6. Remove connector (Y) at backside of pressure control. Remove jam nut (Z) and control board (302).

Installation

When installing replacement control board, follow instructions with control board to set model type.

1. Fig. 8. Install control board (302) and jam nut (Z). Install connector (Y) at backside of pressure control.
2. Install ground wire and control board (302) with six screws (122).
3. Fig. 15. Connect to control board (302):
 - Connect ON/OFF switch connector (B).
 - Lead (E) to transducer.
 - Lead (D) to potentiometer.
4. Fig. 8. Push display connector into PC board close display connector wings (A) on PC board. Install display/cover (52) with four screws (54).

Pressure Control Transducer

Removal

-  1. Relieve pressure; page 4.
2. Fig. 8. Remove four screws (54) and cover (52).
3. Disconnect lead (E) from control board (302).
4. Remove two screws (141) and guard (147). Carefully pull transducer connector through rubber grommet (145).

5. Remove pressure control transducer (61q) and packing o-ring (61p) from filter housing (61e).

Installation

1. Fig. 8. Install packing o-ring (61p) and pressure control transducer (61q) in filter housing (61e). Torque to 30–35 ft-lb.
2. Carefully feed transducer connector through rubber grommet (145). Install guard (147) with two screws (141).
3. Connect lead (E) to motor control board (302).
4. Install cover (52) with four screws (54).

Pressure Adjust Potentiometer

Removal

-  1. Relieve pressure; page 4.
2. Fig. 8. Remove four screws (54) and cover (52) and two screws (139).
3. Disconnect lead (D) from control board (302).
4. Loosen set screws on potentiometer knob (50) and remove knob, shaft nut, lockwasher (310) and pressure adjust potentiometer (310).
5. Remove spacer (74) from potentiometer (310).

Installation

1. Install spacer (74) on potentiometer (310).
2. Fig. 8. Install pressure adjust potentiometer (310), shaft nut, lockwasher (310) and potentiometer knob (50).
 - a. Turn potentiometer shaft (310) clockwise to internal stop. Assemble potentiometer knob (50) to strike pin on plate (29).
 - b. After adjustment of step a., tighten both set screws in knob 1/4 to 3/8 turn after contact with shaft.
3. Connect lead (D) to control board (302).
4. Install plate (29) with two screws (139).
5. Install cover (52) with four screws (54).

Pressure Control Repair

Digital Display Messages



Relieve pressure before repair; page 4. No display does not mean that sprayer is not pressurized.

| DISPLAY | SPRAYER OPERATION | INDICATION | ACTION |
|-------------------------------|---|--|--|
| No Display | Sprayer may be pressurized. | Loss of power or display not connected | Check power source. Relieve pressure before repair or disassembly. Verify display is connected. |
| - - - - | Sprayer may be pressurized. | Pressure less than 200 psi (14 bar, 1.4 MPa) | Increase pressure as needed |
| 3000 psi 210 bar 21 MPa | Sprayer is pressurized. Power is applied. (Pressure varies with tip size and pressure control setting.) | Normal operation | Spray |
| E=02 | Sprayer stops. Engine is running. | Exceeded pressure limit | Remove any filter clogs or flow obstructions. Make sure gun trigger is locked open if using AutoClean valve. |
| E=03 | Sprayer stops. Engine is running. | Pressure transducer faulty, bad connection or broken wire. | Check transducer connections and wire. Replace transducer or control board, if necessary. |
| E=05 | Sprayer stops. Engine is running. | High clutch current | <ol style="list-style-type: none"> 1. Check clutch 7-pin bulk-head connector. Clean contacts. 2. $1.7 \pm 0.2\Omega$ across clutch field at 70°F 3. Replace clutch field assembly |
| E=06 | Sprayer stops. Engine is running. Display alternates E=06. | High clutch temperature | <ol style="list-style-type: none"> 1. If clutch is new, let sprayer cool down and then restart 2. Inspect clutch. Replace clutch if there is excessive wear. 3. Remove pump pin, separate pinion housing from clutch housing. Rotate rotor clockwise to check for excessive drag. |
| E=07 | Sprayer stops. Engine is running. | Pressure greater than 2000 psi (138 bar, 14 MPa) while in Flush Timer Mode | Chase paint from lines before running in flush timer mode. Make sure spray gun is triggered and prime valve is open when using AutoClean |

After a fault, follow these steps to restart sprayer:

1. Correct fault condition
2. Turn sprayer OFF
3. Turn sprayer ON

Displacement Pump

Removal

See manual 309277 for pump repair instructions.

1. Flush pump.
2. Fig. 9. Cycle pump with piston rod (222) in lowest position.
3.  Relieve pressure; page 4.
4. Fig. 9. Remove suction tube (30) and hose (33).

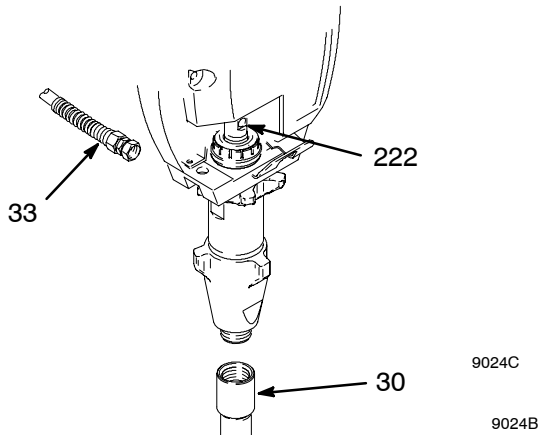

Fig. 9
Repair

Installation

WARNING

If pin works loose, parts could break off due to force of pumping action. Parts could project through the air and result in serious injury or property damage. Make sure pin (101) and retaining clip (71a) are properly installed. See Detail A. Fig. 10.

CAUTION

If the pump locknut loosens during operation, the threads of the bearing housing will be damaged. Make sure locknut is properly tightened.

1. Fig. 12. Pull piston rod out 1.0 in. Screw in pump until holes in housing plates and piston rod align.

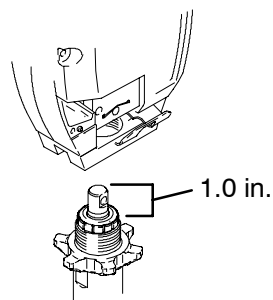

Fig. 12

5. Fig. 10. Use screwdriver to push out pump pin (101).

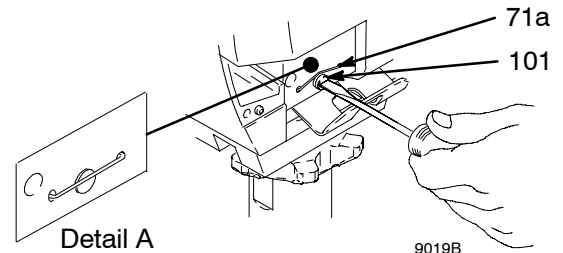

Fig. 10

6. Fig. 11. Loosen locknut by hitting firmly with a 20 oz (maximum) hammer. Unscrew pump.

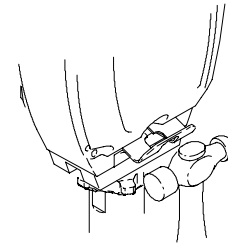

Fig. 11

2. Fig. 10. See Detail A. Push pin (101) into hole until retaining clip (71a) snaps over pin.

Fig. 13. Screw jam nut down onto pump until nut stops. Screw pump up into pump plate until it stops. Back off pump one full turn and align pump outlet to back. Tighten jam nut by hand, then tap 1/8 to 1/4 turn with a 20 oz (maximum) hammer to approximately 75 ±5 ft-lb (102 N·m).

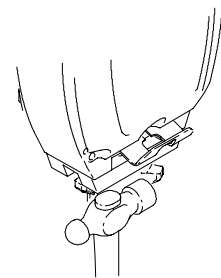

Fig. 13

- Fig. 14. Fill packing nut with Graco TSL until fluid flows onto the top of seal.

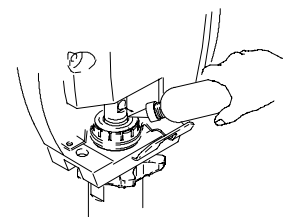

Fig. 14

Displacement Pump

Pump Pin Clip

Removal

1. Remove pump (85).
2. Remove two bolts (107), washers (79), pump bracket (110), pail hook (90) and shield (113).
3. Fig. 10. Remove clip (71a).

Installation

1. Fig. 10. Install clip (71a).
2. Install shield (113), pail hook (90) and pump bracket (110) with two washers (79) and bolts (107). Torque bolts to 40 ft-lb (54 N•m).
3. Install pump (85).

Parts List & Drawing - Pinion Assembly

Ref No. 8 and 71

Ref No. 8: Pinion Housing Assembly 245400

Ref No. 71: Drive Housing Assembly 245444

| Ref No. | Part No. | Description | Qty | Ref No. | Part No. | Description | Qty |
|---------|----------|-----------------------|-----|---------|----------|--------------------------|-----|
| 8a | 245266 | PINION HOUSING, COIL | 1 | 71 | | DRIVE HOUSING | 1 |
| 8b | 105489 | PIN | 2 | 71a | 194060 | RETAINING CLIP, pump pin | 1 |
| 8d | 241114 | PINION SHAFT | | 71b | 193656 | CAM FOLLOWER PLATE | 1 |
| 8e | 112770 | RETAINING RING, large | | 71c | 114691 | CAM FOLLOWER BEARING | 2 |
| | | | | 71d | 114828 | RETAINER CLIP | 2 |
| | | | | 71g | 114697 | WASHER | 1 |
| | | | | 71h | 114698 | WASHER | 1 |
| | | | | 101 | 195523 | PIN | 1 |

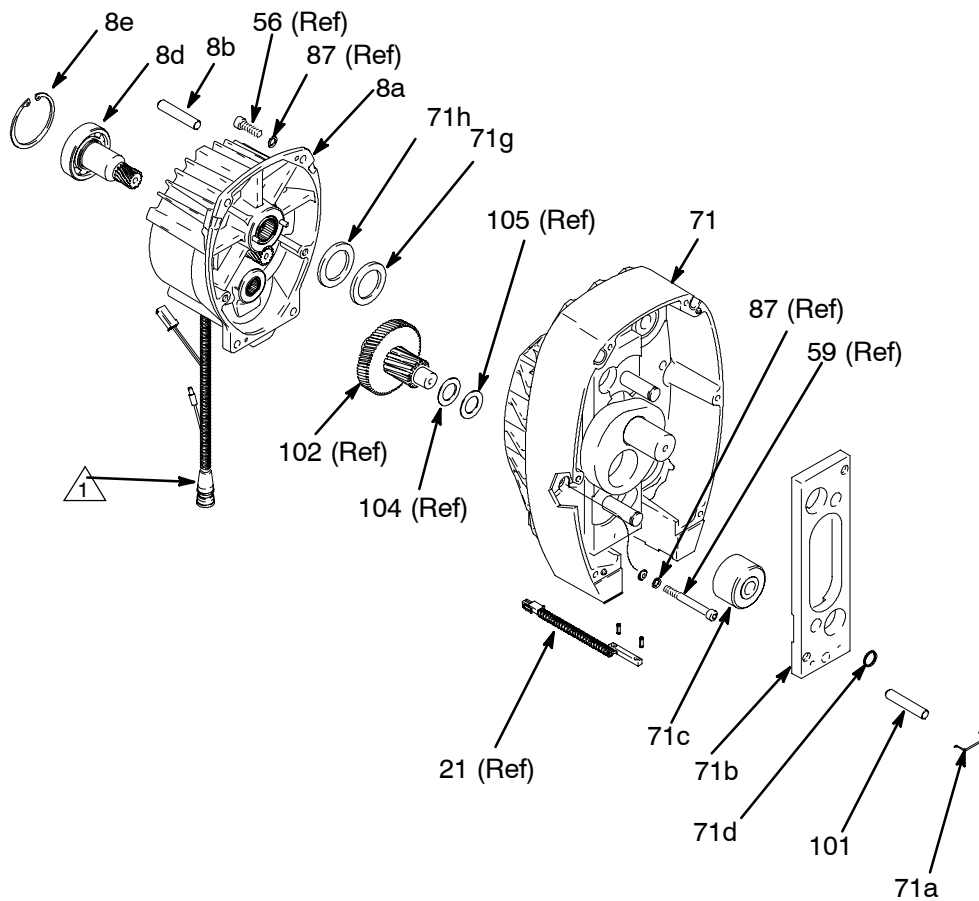

9046C

△ Pinion housing/coil assembly (8a) includes clutch field and all bearings, pins and o-rings

Parts Drawing - Sprayers

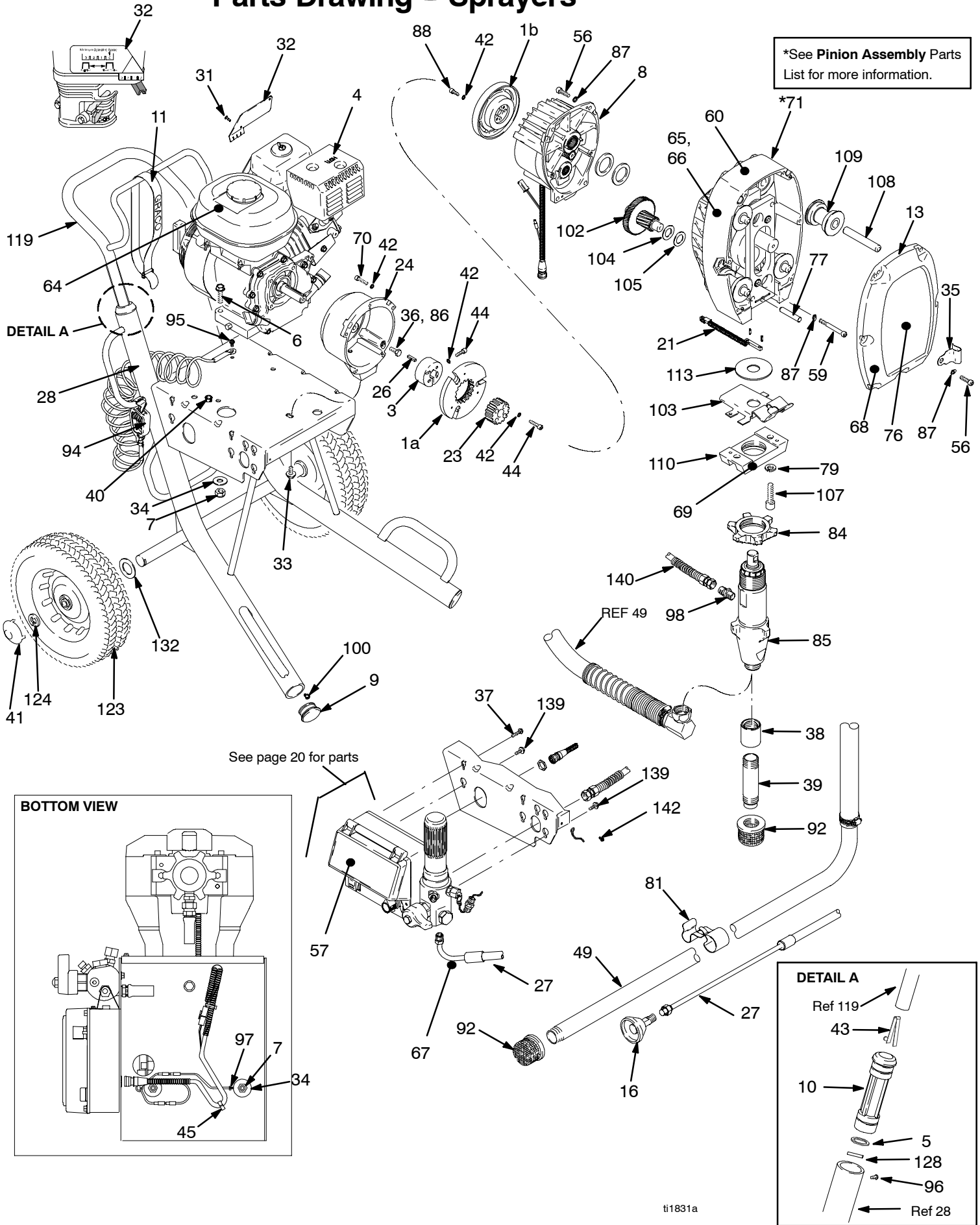

Parts List

Models 233718, 233719

| Ref. No. | Part No. | Description | Qty. | Ref. No. | Part No. | Description | Qty. |
|----------|----------|---|------|----------|----------|--|------|
| 1 | 241113 | CLUTCH, ASSEMBLY includes 1a, 1b, 23, 42, 44, 88, | 1 | 64▲ | 194126 | LABEL, warning | 1 |
| 1a | | ARMATURE, clutch | 1 | 65▲ | 194127 | LABEL, warning | 1 |
| 1b | | ROTOR | 1 | 66▲ | 194317 | LABEL, danger, English | 1 |
| 3 | 193680 | COLLAR, shaft | 1 | 67▲ | 195119 | LABEL, warning tag | 1 |
| 4 | 114530 | ENGINE, gas, 5.5 HP, Honda | 1 | 68▲ | 195519 | LABEL, caution | 1 |
| 5 | 183350 | WASHER | 2 | 69▲ | 192840 | LABEL, warning | 1 |
| 6 | 110837 | SCREW, flange, hex | 2 | 70 | 100644 | SCREW, cap, sch | 5 |
| 7 | 110838 | NUT, lock | 2 | 71 | 245444 | DRIVE HOUSING; Parts page 17 | 1 |
| 8 | 245400 | PINION ASSEMBLY; Parts page 17 | 1 | 76 | 198653 | LABEL, identification | 1 |
| 9 | 193682 | PLUG, tube | 2 | 77 | 195523 | PIN, PUMP | 1 |
| 10 | 191084 | SLEEVE, cart | 2 | 79 | 100018 | WASHER, lock, spring | 2 |
| 11 | 114271 | STRAP, retaining | 1 | 81 | 196723 | CLIP, spring, Lo-Boy only | 1 |
| 13 | 241536 | COVER, assembly | 1 | 84 | 193394 | NUT, retaining | 1 |
| 16 | 241920 | DEFLECTOR, threaded | 1 | 85 | 246257 | DISPLACEMENT PUMP; Manual 309277 | 1 |
| 21 | 116806 | SWITCH, reed w/conn | 1 | 86 | 100214 | WASHER, lock | 4 |
| 24 | 193531 | CLUTCH HOUSING | 1 | 87 | 104008 | WASHER, lock, spring | 12 |
| 26 | 183401 | KEY, parallel | 1 | 88 | 101682 | SCREW, cap, sch | 4 |
| 27 | 246331 | HOSE, drain, Lo-Boy | 1 | 92 | 189920 | STRAINER | 1 |
| | 244240 | HOSE, drain, Hi-Boy | 1 | 94 | 237686 | CLAMP, grounding assy | 1 |
| 28 | 245164 | FRAME, cart GMAX 7900 | 1 | 95 | 112798 | SCREW, thread form, hex hd | 1 |
| 31 | 113084 | RIVET, blind | 2 | 96 | 108795 | SCREW, mach, pnh | 4 |
| 32 | 192014 | PLATE, indicator | 1 | 97 | 240997 | CONDUCTOR, ground | 4 |
| 33 | 113802 | SCREW | 1 | 98 | 162485 | FITTING, nipple, adapter | 3 |
| 34 | 108851 | WASHER | 2 | 100 | 114984 | SCREW, tapping, phil pan hd | 2 |
| 35 | 197124 | CLIP | 1 | 102 | 241539 | GEAR, combination | 1 |
| 36 | 108842 | SCREW | 4 | 103 | 241540 | REPAIR KIT, HOOK, PAIL (includes item 113) | 1 |
| 37 | 198904 | SCREW, #8 | 2 | | | | |
| 38 | 114967 | COUPLING, Hi-Boy only | 1 | 104 | 114699 | WASHER, thrust | 1 |
| 39 | 198122 | TUBE, Hi-Boy only | 1 | 105 | 114672 | WASHER, thrust | 1 |
| 40 | 114678 | GROMMET | 1 | 107 | 110343 | SCREW, cap, sch. | 2 |
| 41 | 104811 | CAP, hub | 2 | 108 | 114695 | PIN, dowel | 4 |
| 42 | 105510 | WASHER, lock, spring (hi-clr) | 15 | 109 | 241322 | ROLLER, assembly | 4 |
| 43 | 112827 | BUTTON, snap | 2 | 110 | 194118 | BRACKET, pump | 1 |
| 44 | 108803 | SCREW, hex, socket head | 6 | 113 | 195377 | SHIELD, paint | 1 |
| 45 | 114687 | CLIP | 1 | 119 | 245245 | HANDLE, cart | 1 |
| 49 | 245249 | TUBE, suction, 30 gal (assembly) | 1 | 123 | 198720 | WHEEL, semi-pneumatic 12 in. | 2 |
| 56 | 101864 | SCREW, cap sch | 10 | 124 | 198723 | AXLE, clip | 2 |
| 57 | 196670 | LABEL, crt1 box cover | 1 | 128 | 108068 | PIN, spring straight | 2 |
| 59 | 114693 | SCREW, cap, socket hd | 2 | 132 | 116891 | WASHER | 2 |
| 60 | 290228 | LABEL, caution | 1 | 139 | 112774 | SCREW, machine | 1 |
| | | | | 140 | 198847 | HOSE, coupled | 1 |
| | | | | 141 | 109575 | SCREW, threadforming | 2 |

▲ Replacement Danger and Warning labels, tags, and cards are available at no cost.

Parts Drawing - Sprayer

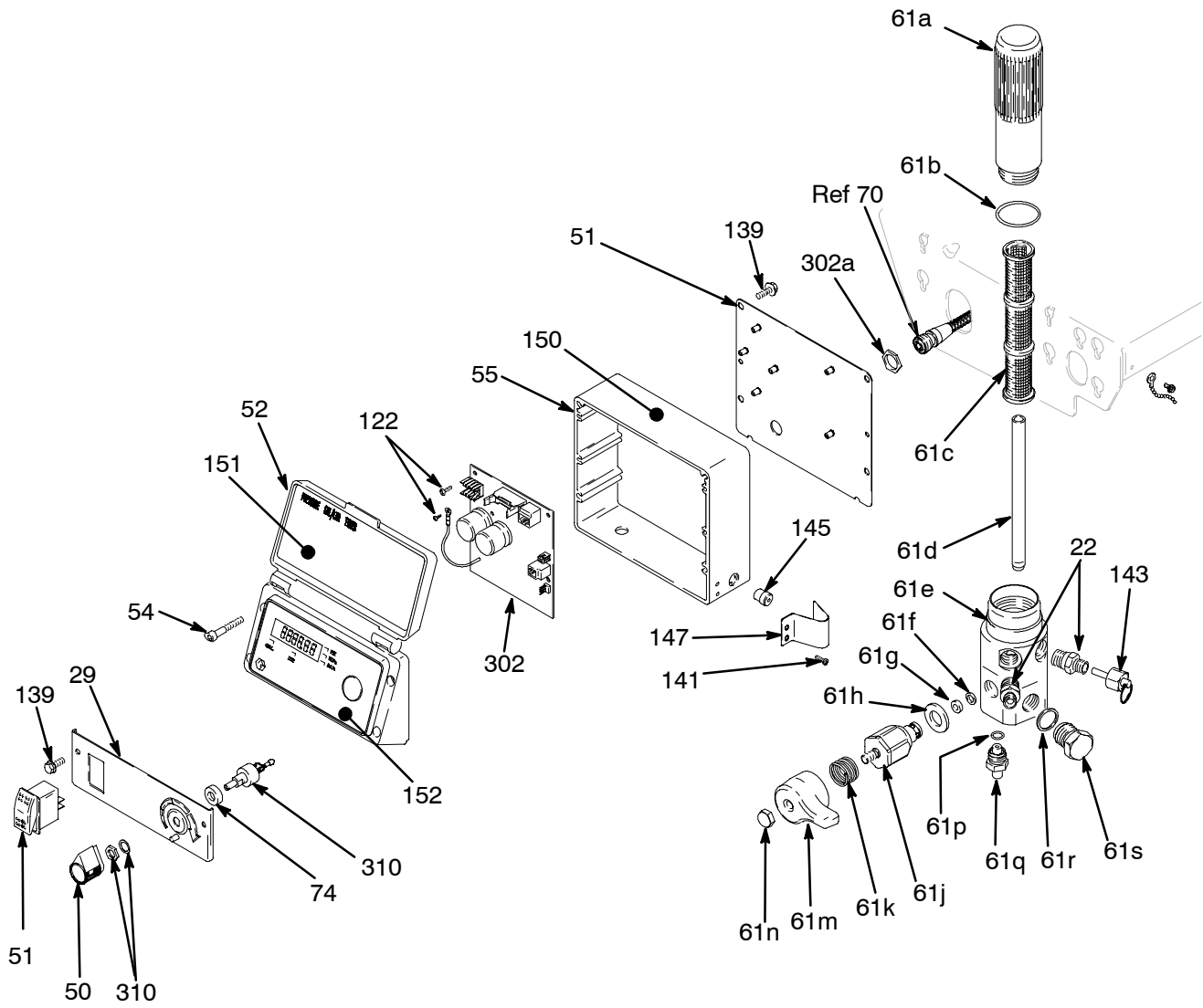

ti1838a

Parts List - Sprayer

| REF NO. | PART NO. | DESCRIPTION | QTY | REF NO. | PART NO. | DESCRIPTION | QTY |
|---------|----------|--|-----|------------|---------------|---|----------|
| 22 | 162485 | ADAPTER | 2 | 61q | 243222 | TRANSDUCER, pressure control includes 61p | 1 |
| 29 | 198553 | PANEL, control | 1 | 61r | 197055 | GASKET, plug | 1 |
| 50 | 116167 | KNOB, potentiometer | 1 | 61s | 196781 | PLUG, AutoClean | 1 |
| 51 | 116752 | SWITCH, rocker, (spst) | 1 | 74 | 198650 | SPACER, shaft | 1 |
| 52 | 245393 | DIGITAL DISPLAY Includes 54, 57, 151, 152 | 1 | 122 | 114331 | SCREW, pnhd 6-32 | 6 |
| 53 | 198534 | PLATE, control | 1 | 133 | 109575 | SCREW, threadformer | 2 |
| 54 | 116252 | SCREW, #8 taptite, phil | 4 | 139 | 112774 | SCREW, mach | 4 |
| 55 | 198548 | HOUSING, control | 1 | 143 | 245475 | PLUG, packless | 1 |
| | | FILTER, fluid | 1 | 145 | 114296 | BUSHING, step | 1 |
| 61 | 245396 | KIT, repair, filter (includes 61a-61s) | 1 | 147 | 198994 | GUARD, transducer | 1 |
| 61a | 196675 | BOWL, filter | 1 | 150▲ | 189246 | LABEL, warning | 1 |
| 61b | 104361 | O-RING | 1 | 151 | 198884 | LABEL, instruction, GMax | 1 |
| 61c | 244067 | STRAINER, mesh, 60 | 1 | 152 | 198648 | LABEL, GMax, LCD | 1 |
| 61d | 196786 | TUBE, diffuser | 1 | 302 | 245394 | BOARD, PC Includes 302a | 1 |
| 61e | 245401 | KIT, repair, filter base | 1 | 302a | | NUT, nylon | 1 |
| 61f | 193710 | SEAL, valve | 1 | 310 | 241443 | POTENTIOMETER, pressure control | 1 |
| 61g | 193709 | SEAT, valve | 1 | | | | |
| 61h | 114797 | GASKET | 1 | | | | |
| 61j | 245103* | VALVE | 1 | | | | |
| 61k | 114708 | SPRING, compression | 1 | | | | |
| 61m | 194102 | HANDLE, valve | 1 | | | | |
| 61n | 114688 | NUT, cap, hex hd | 1 | | | | |
| 61p | 111457 | O-RING | 1 | | | | |

* Drain valve replacement kit 245103 includes 61f, 61g, 61h, 61k, 61m, and 61n.

▲ Replacement Danger and Warning labels, tags, and cards are available at no cost.

Pressure Control Wiring Diagram

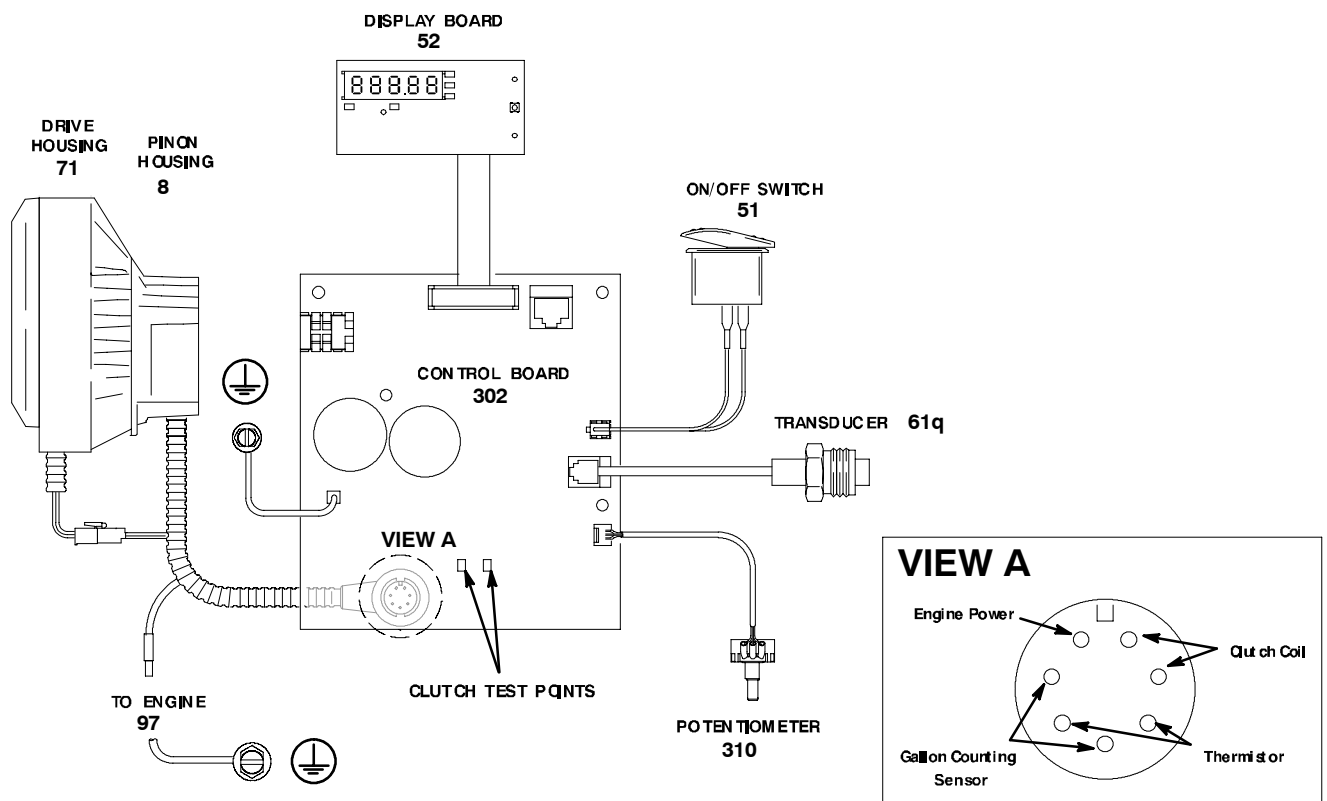

Fig. 15

t11834a

Parts List/Drawing - Sprayers with RAC 5 Tip, Gun & Hose

Models 233720, 233721

Includes items 201 to 204

| Ref No. | Part No. | Description | Qty |
|---------|----------|--|-----|
| 201 | 233719 | Hi-Boy Sprayer See parts list on page 19 | 1 |
| | 233718 | Lo-Boy Sprayer See parts list on page 19 | 1 |
| 202 | 240797 | HOSE, grounded, nylon; 3/8 in. ID; cpld 3/8 npsm(fbe); 50 foot (15 m); spring guards both ends 3300 psi (227 bar, 27.7 MPa) | 1 |
| 203 | 238358 | HOSE, grounded, nylon; 3/16 in. ID; cpld 1/4 npsm(m) x 1/4 npsm(f) swivel; 3 foot (0.9 m); spring guards both ends | 1 |
| 204 | 246220 | CONTRACTOR SPRAY GUN Includes RAC X 517-size SwitchTip™ and HandTite™ Guard See 309639 for parts | 1 |
| 205 | 159841 | ADAPTER | 1 |

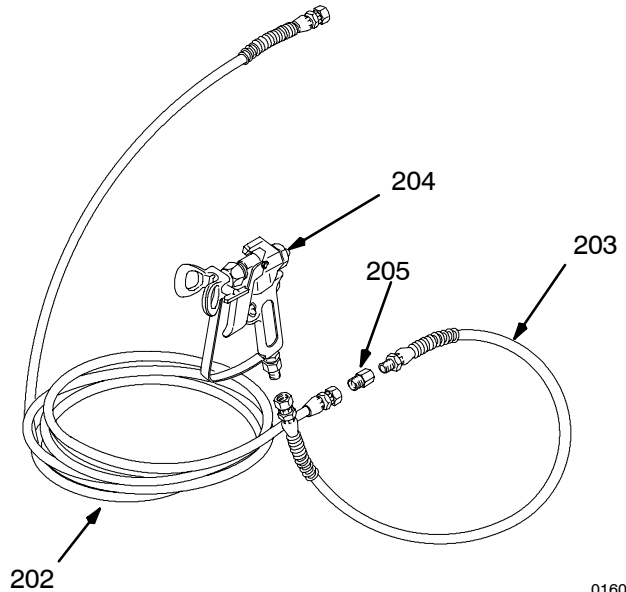

Accessories

DANGER LABELS

An English language DANGER label is on your sprayer. If you have painters who do not read English, order one of the following labels to apply to your sprayer. The drawing shows the best placement of these labels for good visibility.

Order the labels from your Graco distributor.

| | |
|---------|--------|
| French | 194931 |
| Spanish | 194932 |
| German | 194933 |
| Greek | 194934 |
| Korean | 194935 |
| English | 194125 |

Apply other language here

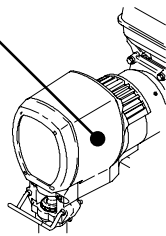

Displacement Pump Repair Kits

Packing repair kits.

GMax 7900

240916

Technical Data

Honda GX160 Engine
 Power Rating @ 3700 rpm
 ANSI 5.5 Horsepower
 DIN 6270B/DIN 6271
 NA 2.9 Kw - 4.0 Ps
 NB 3.6 Kw - 4.9 Ps
 Maximum working pressure 3300 psi
 (227 bar, 22.7 MPa)
 Noise Level
 Sound power 105 dBa
 per ISO 3744
 Sound pressure 96 dBa
 measured at 3.1 feet (1 m)
 Cycles/gallon (liter) 69 (18)

Maximum delivery rating 2.1 gpm (7.9 liter/min)
 Maximum tip size 1 gun with 0.046 in. tip
 2 guns with 0.033 in. tip
 3 guns with 0.026 in. tip
 4 guns with 0.022 in. tip
 Inlet paint strainer 16 mesh (1190 micron)
 stainless steel screen, reusable
 Outlet paint filter 60 mesh (250 micron)
 stainless steel screen, reusable
 Pump inlet size 3/4 in. npt (m)
 Fluid outlet size 3/8 npsm from fluid filter
 Wetted parts zinc-plated carbon steel,
 PTFE, Nylon, UHMW polyethylene,
 Viton®, Delrin®, leather, aluminum, tungsten carbide,
 nickel and zinc-plated carbon steel, stainless steel,
 chrome plating, PEEK

NOTE: Delrin®, PTFE, Viton® are trademarks of the DuPont Company.

Dimensions

Model 233718, 233720

Lo-Boy Cart without hose or gun

Weight (dry, without packaging) 180 lb (82.1 kg)
 Height 41 in. (104.1 cm)
 Length 39 in. (99.1 cm)
 Width 22 in. (55.9 cm)

Model 233719, 233721

Hi-Boy without hose or gun

Weight (dry, without packaging) 175 lb (79.4 kg)
 Height 41 in. (104.1 cm)
 Length 39 in. (99.1 cm)
 Width 22 in. (55.9 cm)

Graco Standard Warranty

Graco warrants all equipment manufactured by Graco and bearing its name to be free from defects in material and workmanship on the date of sale by an authorized Graco distributor to the original purchaser for use. With the exception of any special, extended, or limited warranty published by Graco, Graco will, for a period of twelve months from the date of sale, repair or replace any part of the equipment determined by Graco to be defective. This warranty applies only when the equipment is installed, operated and maintained in accordance with Graco's written recommendations.

This warranty does not cover, and Graco shall not be liable for general wear and tear, or any malfunction, damage or wear caused by faulty installation, misapplication, abrasion, corrosion, inadequate or improper maintenance, negligence, accident, tampering, or substitution of non-Graco component parts. Nor shall Graco be liable for malfunction, damage or wear caused by the incompatibility of Graco equipment with structures, accessories, equipment or materials not supplied by Graco, or the improper design, manufacture, installation, operation or maintenance of structures, accessories, equipment or materials not supplied by Graco.

This warranty is conditioned upon the prepaid return of the equipment claimed to be defective to an authorized Graco distributor for verification of the claimed defect. If the claimed defect is verified, Graco will repair or replace free of charge any defective parts. The equipment will be returned to the original purchaser transportation prepaid. If inspection of the equipment does not disclose any defect in material or workmanship, repairs will be made at a reasonable charge, which charges may include the costs of parts, labor, and transportation.

THIS WARRANTY IS EXCLUSIVE, AND IS IN LIEU OF ANY OTHER WARRANTIES, EXPRESS OR IMPLIED, INCLUDING BUT NOT LIMITED TO WARRANTY OF MERCHANTABILITY OR WARRANTY OF FITNESS FOR A PARTICULAR PURPOSE.

Graco's sole obligation and buyer's sole remedy for any breach of warranty shall be as set forth above. The buyer agrees that no other remedy (including, but not limited to, incidental or consequential damages for lost profits, lost sales, injury to person or property, or any other incidental or consequential loss) shall be available. Any action for breach of warranty must be brought within two (2) years of the date of sale.

Graco makes no warranty, and disclaims all implied warranties of merchantability and fitness for a particular purpose in connection with accessories, equipment, materials or components sold but not manufactured by Graco. These items sold, but not manufactured by Graco (such as electric motors, switches, hose, etc.), are subject to the warranty, if any, of their manufacturer. Graco will provide purchaser with reasonable assistance in making any claim for breach of these warranties.

In no event will Graco be liable for indirect, incidental, special or consequential damages resulting from Graco supplying equipment hereunder, or the furnishing, performance, or use of any products or other goods sold hereto, whether due to a breach of contract, breach of warranty, the negligence of Graco, or otherwise.

FOR GRACO CANADA CUSTOMERS

The parties acknowledge that they have required that the present document, as well as all documents, notices and legal proceedings entered into, given or instituted pursuant hereto or relating directly or indirectly hereto, be drawn up in English. Les parties reconnaissent avoir convenu que la rédaction du présente document sera en Anglais, ainsi que tous documents, avis et procédures judiciaires exécutés, donnés ou intentés à la suite de ou en rapport, directement ou indirectement, avec les procédures concernées.

ADDITIONAL WARRANTY COVERAGE

Graco does provide extended warranty and wear warranty for products described in the "Graco Contractor Equipment Warranty Program".

Graco Phone Number

TO PLACE AN ORDER, contact your Graco distributor, or call **1-800-690-2894** to identify your closest distributor.

*All written and visual data contained in this document reflects the latest product information available at the time of publication.
Graco reserves the right to make changes at any time without notice.*

MM 309412

Graco Headquarters: Minneapolis
International Offices: Belgium, China, Japan, Korea

GRACO INC. P.O. BOX 1441 MINNEAPOLIS, MN 55440-1441

www.graco.com

PRINTED IN USA 309412E 1/2002 Rev. 08/2009