

GMAX™ 3400 Airless Sprayers

310813E
EN

- For Portable Airless Spraying of Architectural Coatings and Paints. For professional use only.-



3300 psi (22.8 MPa, 228 bar) Maximum Working Pressure

Korean patent: 10-0647761

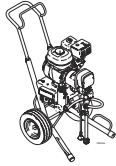

Important Safety Instructions

Read all warnings and instructions in this manual. Save these instructions.

			
248664	✓		✓
248666		✓	✓

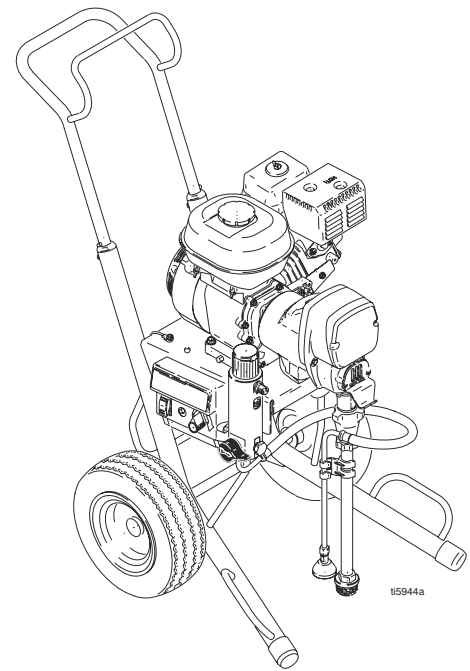

Related Manuals



310802



311861

309250







309640









Contents

WARNING	3	GMAX 3400 Hi-Boy Sprayers	16
Maintenance	5	Pinion Housing	18
Troubleshooting	6	GMAX 3400 Lo-Boy Sprayers	20
Drive Housing and Connecting Rod	8	Pressure Control/Filter Assembly	22
Pinion Assembly/Clutch Armature/Clamp	9	Pressure Control Wiring Diagram	23
Clutch Housing	11	Complete Sprayers	24
Engine	11	Technical Data	25
Pressure Control	12	Dimensions	25
Displacement Pump	14	Graco Standard Warranty	26
Parts	16		

Warning

The following warnings include general safety information for this equipment. Further product specific warnings may be included in the text where applicable.

 WARNING	
	<p>FIRE AND EXPLOSION HAZARD</p> <p>Flammable fumes, such as solvent and paint fumes, in work area can ignite or explode. To help prevent fire and explosion:</p> <ul style="list-style-type: none"> • Use equipment only in well ventilated area. Do not fill fuel tank while engine is running or hot; shut off engine and let it cool. Fuel is flammable and can ignite or explode if spilled on hot surface. • Do not fill fuel tank while engine is running or hot; shut off engine and let it cool. Fuel is flammable and can ignite or explode if spilled on hot surface. • When flammable liquid is sprayed or used for flushing or cleaning, keep sprayer at least 20 feet (6 m) away from explosive vapors. • Eliminate all ignition sources; such as pilot lights, cigarettes, portable electric lamps, and plastic drop cloths (potential static arc). • Keep work area free of debris, including solvent, rags and gasoline. • Do not plug or unplug power cords, or turn power or light switches on or off when flammable fumes are present. • Ground equipment and conductive objects in work area. See Grounding instructions. • Use only grounded hoses. • Hold gun firmly to side of grounded pail when triggering into pail. • If there is static sparking or you feel a shock, stop operation immediately. Do not use equipment until you identify and correct the problem.
	<p>INJECTION HAZARD</p> <p>High-pressure fluid from gun, hose leaks, or ruptured components will pierce skin. This may look like just a cut, but it is a serious injury that can result in amputation. Get immediate medical attention.</p> <ul style="list-style-type: none"> • Do not point gun at anyone or at any part of the body. • Do not put your hand over the spray tip. • Do not stop or deflect leaks with your hand, body, glove, or rag. • Do not spray without tip guard and trigger guard installed. • Engage trigger lock when not spraying. • Follow Pressure Relief Procedure in this manual, when you stop spraying and before cleaning, checking, or servicing equipment.
	<p>PRESSURIZED EQUIPMENT HAZARD</p> <p>Fluid from the gun/dispense valve, leaks, or ruptured components can splash in the eyes or on skin and cause serious injury.</p> <ul style="list-style-type: none"> • Follow Pressure Relief Procedure in this manual, when you stop spraying and before cleaning, checking, or servicing equipment. • Tighten all fluid connections before operating the equipment. • Check hoses, tubes, and couplings daily. Replace worn or damaged parts immediately.
	<p>MOVING PARTS HAZARD</p> <p>Moving parts can pinch or amputate fingers and other body parts.</p> <ul style="list-style-type: none"> • Keep clear of moving parts. • Do not operate equipment with protective guards or covers removed. • Pressurized equipment can start without warning. Before checking, moving, or servicing equipment, follow the Pressure Relief Procedure in this manual. Disconnect power or air supply.

 WARNING	
	<p>EQUIPMENT MISUSE HAZARD</p> <p>Misuse can cause death or serious injury.</p> <ul style="list-style-type: none"> • Do not exceed the maximum working pressure or temperature rating of the lowest rated system component. See Technical Data in all equipment manuals. • Use fluids and solvents that are compatible with equipment wetted parts. See Technical Data in all equipment manuals. Read fluid and solvent manufacturer's warnings. • Check equipment daily. Repair or replace worn or damaged parts immediately. • Do not alter or modify equipment. • Use equipment only for its intended purpose. Call your Graco distributor for information. • Route hoses and cables away from traffic areas, sharp edges, moving parts, and hot surfaces. • Do not use hoses to pull equipment. • Keep children and animals away from work area. • Comply with all applicable safety regulations.
	<p>PRESSURIZED ALUMINUM PARTS HAZARD</p> <p>Do not use 1,1,1-trichloroethane, methylene chloride, other halogenated hydrocarbon solvents or fluids containing such solvents in pressurized aluminum equipment. Such use can cause serious chemical reaction and equipment rupture, and result in death, serious injury, and property damage.</p>
	<p>SUCTION HAZARD</p> <p>Never place hands near the pump fluid inlet when pump is operating or pressurized. Powerful suction could cause serious injury.</p>
	<p>CARBON MONOXIDE HAZARD</p> <p>Exhaust contains poisonous carbon monoxide, which is colorless and odorless. Breathing carbon monoxide can cause death. Do not operate in an enclosed area.</p>
	<p>TOXIC FLUID OR FUMES HAZARD</p> <p>Toxic fluids or fumes can cause serious injury or death if splashed in the eyes or on skin, inhaled, or swallowed.</p> <ul style="list-style-type: none"> • Read MSDS's to know the specific hazards of the fluids you are using. • Store hazardous fluid in approved containers, and dispose of it according to applicable guidelines.
	<p>BURN HAZARD</p> <p>Equipment surfaces and fluid that's heated can become very hot during operation. To avoid severe burns, do not touch hot fluid or equipment. Wait until equipment/fluid has cooled completely.</p>
	<p>PERSONAL PROTECTIVE EQUIPMENT</p> <p>You must wear appropriate protective equipment when operating, servicing, or when in the operating area of the equipment to help protect you from serious injury, including eye injury, inhalation of toxic fumes, burns, and hearing loss. This equipment includes but is not limited to:</p> <ul style="list-style-type: none"> • Protective eyewear • Clothing and respirator as recommended by the fluid and solvent manufacturer • Gloves • Hearing protection
	<p>RECOIL HAZARD</p> <p>Brace yourself; gun may recoil when triggered and cause you to fall, which could cause serious injury.</p>

Maintenance

Pressure Relief Procedure

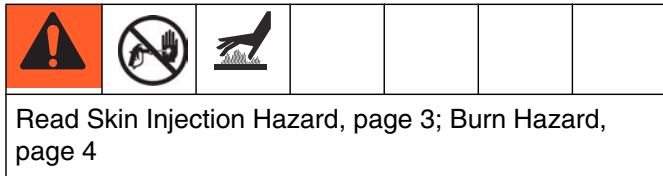

1. Lock gun trigger safety.
2. Turn engine ON/OFF switch to OFF.
3. Move pump switch to OFF and turn pressure control knob fully counterclockwise.
4. Unlock trigger safety. Hold metal part of gun firmly to side of grounded metal pail, and trigger gun to relieve pressure.
5. Lock gun trigger safety.
6. Open pressure drain valve. Leave valve open until ready to spray again.

If you suspect that the spray tip or hose is completely clogged, or that pressure has not been fully relieved after following the steps above, VERY SLOWLY loosen tip guard retaining nut or hose end coupling to relieve pressure gradually, then loosen completely. Now clear tip or hose.

NOTICE

For detailed engine maintenance and specifications, refer to separate Honda Engines Owner's Manual, supplied.

DAILY: Check engine oil level and fill as necessary.

DAILY: Check hose for wear and damage.

DAILY: Check gun safety for proper operation.

DAILY: Check pressure drain valve for proper operation.

DAILY: Check and fill the gas tank.

DAILY: Check level of TSL in displacement pump packing nut. Fill nut, if necessary. Keep TSL in nut to help prevent fluid buildup on piston rod and premature wear of packings and pump corrosion.

AFTER THE FIRST 20 HOURS OF OPERATION:

Drain engine oil and refill with clean oil. Reference Honda Engines Owner's Manual for correct oil viscosity.

WEEKLY: Remove engine air filter cover and clean element. Replace element, if necessary. If operating in an unusually dusty environment: check filter daily and replace, if necessary.

Replacement elements can be purchased from your local HONDA dealer.

AFTER EACH 100 HOURS OF OPERATION:

Change engine oil. Reference Honda Engines Owner's Manual for correct oil viscosity.

SPARK PLUG: Use only BPR6ES (NGK) or W20EPR-U (NIPPONDENSO) plug. Gap plug to 0.028 to 0.031 in. (0.7 to 0.8 mm). Use spark plug wrench when installing and removing plug.

Troubleshooting

Problem	Cause	Solution
Engine will not start	Engine switch is OFF	Turn engine switch ON
	Engine is out of gasoline	Refill gas tank. Honda Engines Owner's Manual.
	Engine oil level is low	Try to start engine. Replenish oil, if necessary. Honda Engines Owner's Manual.
	Spark plug is disconnected or damaged	Connect spark plug cable or replace spark plug
	Cold engine	Use choke
	Fuel shutoff lever is OFF	Move lever to ON position
	Oil is seeping into combustion chamber	Remove spark plug. Pull starter 3 to 4 times. Clean or replace spark plug. Start engine. Keep sprayer upright to avoid oil seepage
Engine operates, but displacement pump does not operate	Pump switch is OFF	Turn pump switch ON
	Pressure setting too low	Turn pressure adjusting knob clockwise to increase pressure.
	Fluid filter (29) is dirty	Clean filter. Page 22.
	Tip or tip filter is clogged	Clean tip or tip filter. Manual 311861.
	Displacement pump piston rod is stuck due to dried paint	Repair pump. Manual 309250.
	Connecting rod is worn or damaged	Replace connecting rod. Page 8.
	Drive housing is worn or damaged	Replace drive housing. Page 8.
	Electrical power is not energizing clutch field	<p>Check wiring connections. Page 11.</p> <p>Reference pressure control repair. Page 13.</p> <p>Reference wiring diagram. Page 23.</p> <p>With pump switch ON and pressure turned to MAXIMUM, use a test light to check for power between clutch test points on control board.</p> <p>Remove clutch wires from control board and measure resistance across clutch coil. At 70° F, the resistance must be between 1.2 +0.2Ω; if not, replace pinion housing.</p> <p>Have pressure control checked by authorized Graco dealer</p>
	Clutch is worn, damaged, or incorrectly positioned	Adjust or replace clutch. Page 9.
	Pinion assembly is worn or damaged	Repair or replace pinion assembly. Page 9.

Problem	Cause	Solution
Pump output is low	Strainer (16) is clogged	Clean strainer.
	Piston ball (206) is not seating	Service piston ball. Manual 309250.
	Piston packings are worn or damaged	Replace packings. Manual 309250.
	O-ring (227) in pump is worn or damaged	Replace o-ring. Manual 309250.
	Intake valve ball is not seating properly	Clean intake valve. Manual 309250.
	Intake valve ball is packed with material	Clean intake valve. Manual 309250.
	Engine speed is too low	Increase throttle setting. Manual 310802.
	Clutch is worn or damaged	Adjust or replace clutch. Page 9.
	Pressure setting is too low	Increase pressure. Manual 310802.
	Fluid filter (29), tip filter or tip is clogged or dirty	Clean filter. Manual 310802 or 311861.
	Large pressure drop in hose with heavy materials	Use larger diameter hose and/or reduce overall length of hose. Use of more than 100 ft of 1/4 in. hose significantly reduces performance of sprayer. Use 3/8 in. hose for optimum performance (50 ft minimum).
Excessive paint leakage into throat packing nut	Throat packing nut is loose	Remove throat packing nut spacer. Tighten throat packing nut just enough to stop leakage.
	Throat packings are worn or damaged	Replace packings. Manual 309250.
	Displacement rod is worn or damaged	Replace rod. Manual 309250.
Fluid is spitting from gun	Air in pump or hose	Check and tighten all fluid connections. Prime pump. Manual 310802.
	Tip is partially clogged	Clear tip. Manual 311861.
	Fluid supply is low or empty	Refill fluid supply. Prime pump. Manual 310802. Check fluid supply often to prevent running pump dry.
Pump is difficult to prime	Air in pump or hose	Check and tighten all fluid connections. Reduce engine speed and cycle pump as slowly as possible during priming.
	Intake valve is leaking	Clean intake valve. Be sure ball seat is not nicked or worn and that ball seats well. Reassemble valve.
	Pump packings are worn	Replace pump packings. Manual 309250.
	Paint is too thick	Thin the paint according to the supplier's recommendations
	Engine speed is too high	Decrease throttle setting before priming pump. Manual 310802.
Clutch squeaks each time clutch engages	Clutch surfaces are not matched to each other when new and may cause noise	Clutch surfaces need to wear into each other. Noise will dissipate after a day of run time.
High engine speed at no load	Misadjusted throttle setting	Reset throttle to 3300 engine rpm at no load
	Worn engine governor	Replace or service engine governor

Drive Housing and Connecting Rod

NOTE: The item numbers referenced are for the Hi-Boy models. The Lo-Boy models may have different item numbers. Use the Hi-Boy item number and part to find the corresponding Lo-Boy part and item number.

Removal

Read Skin Injection Hazard, page 3; Burn Hazard, page 4						

1. Relieve pressure, page 5.
2. FIG. 1. Remove screws (10) and front cover (62).
3. Remove pump. Refer to **Displacement Pump, Removal**, page 14.
4. Remove four screws (18) from drive housing (49).

NOTICE
Thrust washers may stick to grease inside of drive housing. Do not lose or misplace.

5. Pull connecting rod (6) and lightly tap lower rear of drive housing (49) with plastic mallet to loosen from pinion housing (50). Pull drive housing and connecting rod assembly off pinion housing.
6. Inspect crank (B) and connecting rod (6) for excessive wear and replace parts as needed.

Installation

1. Evenly lubricate inside of bronze bearing (C) in drive housing (49) with high-quality motor oil. Liberally pack top roller bearing (E), lower bearing (D) inside connecting rod (6) with bearing grease.
2. Assemble connecting rod (6) to drive housing (49). Rotate connecting rod to lowest position.
3. Apply grease to washers 52, 57 and 56. Install in order shown in FIG. 2.
4. Lubricate gears with 0.26 pint of 110293 grease (supplied with drive housing). Pack grease evenly around gears.
5. Clean mating surfaces of pinion and drive housings.
6. Align connecting rod with crank (B) and carefully align locating pins in drive housing (49) with holes in pinion housing (50). Push drive housing onto pinion housing or tap into place with plastic mallet.

NOTICE
DO NOT use drive housing screws (18) to align or seat bearing housing with drive housing. Align these parts with locating pins, to avoid premature bearing wear.

7. Install screws (18) in drive housing. Torque evenly to note 3 value in Fig. 1.
8. Install pump. Refer to **Displacement Pump, Installation**, page 14.

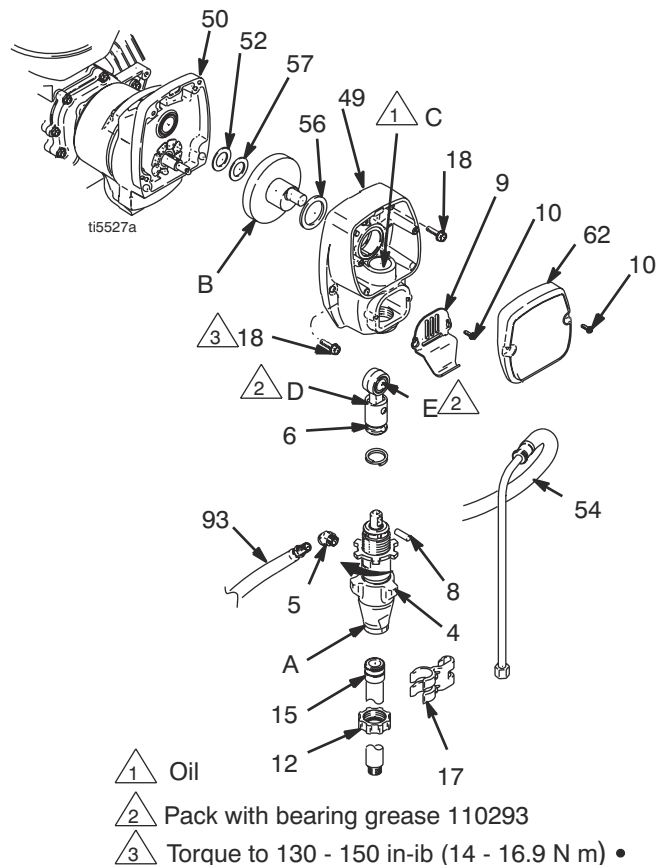

FIG. 1

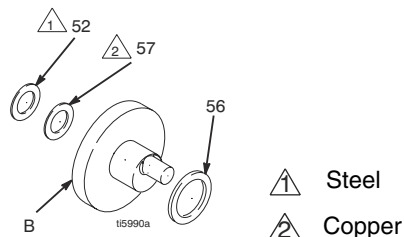





FIG. 2

Pinion Assembly/Clutch Armature/Clamp

Pinion Assembly/Clutch Armature Removal

Pinion Assembly

If pinion assembly (50) is not removed from clutch housing (51), do 1. through 3. Otherwise, start at 4.

						
Read Skin Injection Hazard, page 3; Burn Hazard, page 4						

1. Relieve pressure, page 5.
2. Remove drive housing; page 8.
3. FIG. 14. Disconnect clutch (A) and clutch (B) connectors from control board.
 - a. Remove two screws (91) and swing down cover (77).
 - b. Remove strain relief 24b.
4. FIG. 3. Remove four screws (18) and pinion assembly (50).

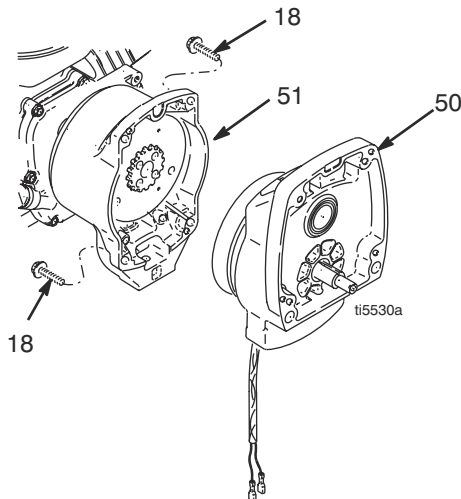

FIG. 3

5. FIG. 4. Place pinion assembly (50) on bench with rotor side up.
6. Remove four screws (41) and lock washers (34). Install two screws in threaded holes (E) in rotor. Alternately tighten screws until rotor comes off.

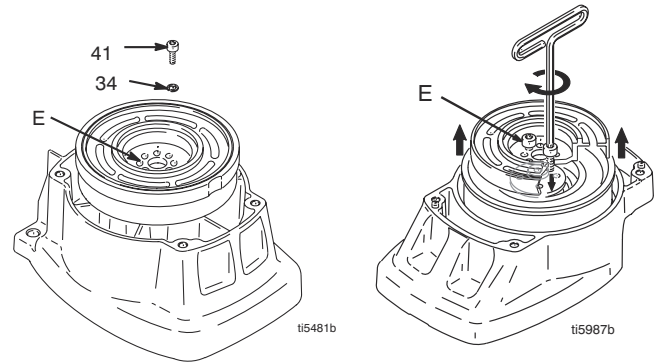

FIG. 4

7. FIG. 5. Remove retaining ring (50d).
8. Turn pinion assembly over and tap pinion shaft (50c) out with plastic mallet.

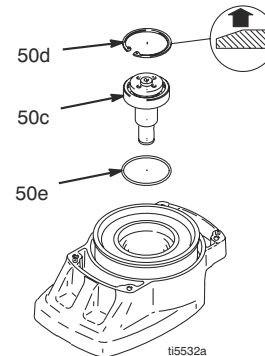

FIG. 5

Clutch Armature

9. FIG. 6. Use an impact wrench or wedge something between clutch armature (38) and clutch housing to hold engine shaft during removal.
10. Remove four screws (35) and lock washers (34).
11. Remove armature (38).

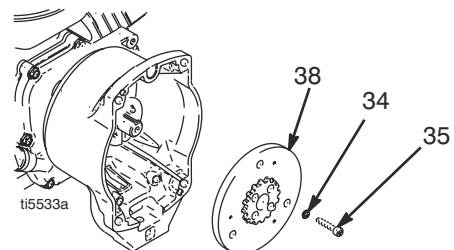

FIG. 6

Installation

Clutch Armature

1. FIG. 7. Lay two stacks of two dimes on smooth bench surface.
2. Lay armature (38) on two stacks of dimes.
3. Press center of hub down to bench surface.

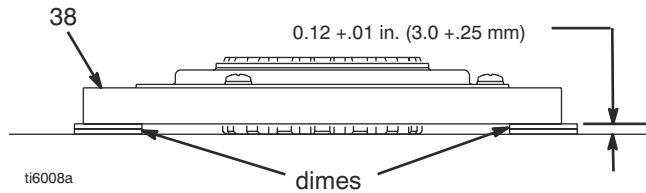
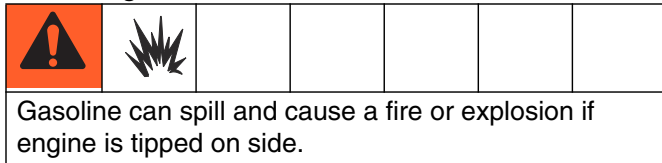

FIG. 7

Clamp Removal

1. Do **Engine Removal**.



2. Drain gasoline from tank according to Honda manual.
3. FIG. 8. Tip engine on side so gas tank is down and air cleaner is up.
4. FIG. 9. Loosen two screws (35) on clamp (37),
5. Push screwdriver into slot in clamp (37) and remove clamp.

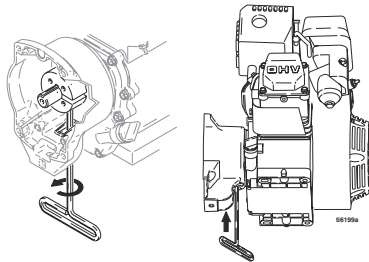

FIG. 8

Clamp Installation

1. FIG. 9 Install engine shaft key (36)
2. Tap clamp (37) onto engine shaft (A). Maintain dimension shown note 2. Chamfer must face engine.
3. Check dimension: Place rigid, straight steel bar (B) across face of clutch housing (51). Use accurate measuring device to measure distance between bar and face of clamp. Adjust clamp as necessary. Torque two screws (35) to 125 ± 10 in-lb (14 ± 1.1 N·m)

4. Install armature (38) on engine drive shaft.
5. Install four screws (35) and lock washers (34) with torque of 125 in-lb.

Pinion Assembly

6. Install o-ring (50e).
7. FIG. 5. Tap pinion shaft (50c) in with plastic mallet.
8. Install retaining ring (50d) with beveled side facing up.
9. FIG. 4. Place pinion assembly on bench with rotor side up.
10. Apply locktite to screws. Install four screws (41) and lock washers (34). Alternately torque screws to 125 in-lb until rotor is secure. Use threaded holes to hold rotor.
11. FIG. 3. Install pinion assembly (50) with four screws (18).
12. FIG. 4. Connect clutch (A) and clutch (B) connectors to control board.

- ① Face of clutch housing
- ② 1.550 ± 0.010 in. (39.37 ± 0.25 mm)
- ③ Torque to 125 ± 10 in-lb (14 ± 1.1 N·m)
- ④ Chamfer this side

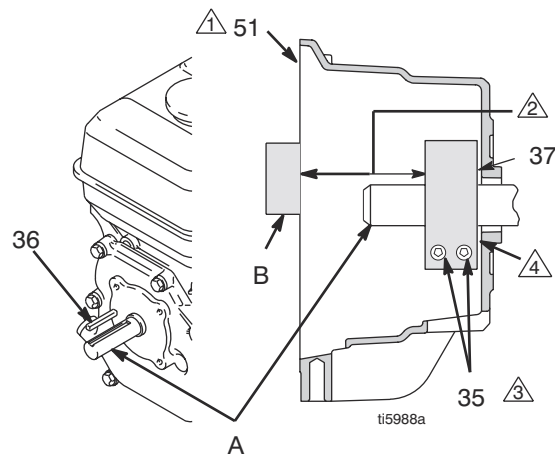

FIG. 9

Clutch Housing

Removal

1. Remove clamp. Do **Clamp Removal**, page 10.
2. FIG. 10. Remove four screws (60) and lock washers (59) which hold clutch housing (51) to engine.
3. Remove screw (64) from under mounting plate (D).
4. Pull off clutch housing (51).

Installation

1. FIG. 10. Push on clutch housing (51).
2. Install four capscrews (60) and lock washers (59) and secure clutch housing (51) to engine. Torque to 200 in-lb (22.6 N·m).
3. Install screw (64) from beneath mounting plate (D). Torque to 26 ft-lb (35.2 N·m).

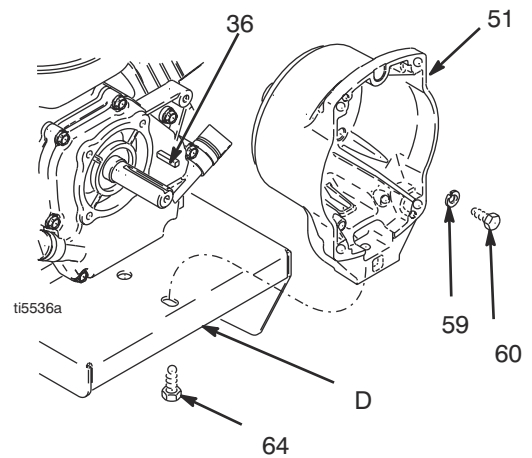

FIG. 10

Engine

Removal

NOTE: All service to the engine must be performed by an authorized HONDA dealer.

1. Remove **Pinion Assembly/Clutch Armature/Clamp** and **Clutch Housing**, as instructed on pages 9, 10 and 11.
2. FIG. 11. Disconnect all necessary wiring.
3. FIG. 12. Remove two locknuts (3) and screws (2) from base of engine.
4. Lift engine carefully and place on work bench.

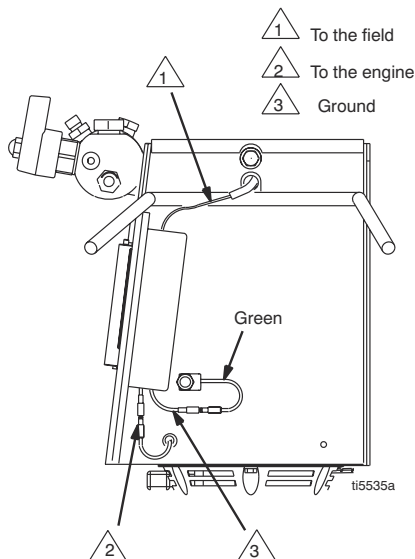

FIG. 11

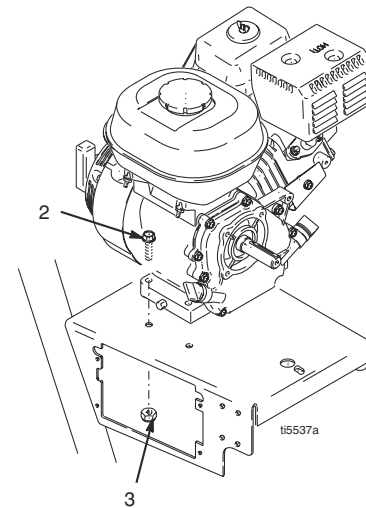

FIG. 12



Installation

1. Lift engine carefully and place on cart.
2. FIG. 12. Install two screws (2) in base of engine and secure with locknuts (3). Torque to 20 ft-lb (27.12 N·m).
3. FIG. 11. Connect all necessary wiring.
4. Install **Pinion Assembly/Clutch Armature/Clamp** and **Clutch Housing**, as instructed on pages 9 and 10 and 11.
5. Set engine to 3300 rpm.

Pressure Control

On/Off Switch

Removal

						
Read Skin Injection Hazard, page 3; Burn Hazard, page 4						

1. Relieve pressure, page 5.
2. FIG. 13. Remove two screws (91) and swing down cover (77).
3. Disconnect ON/OFF switch connector (B) from PC board.
4. Press in on two retaining tabs on each side of ON/OFF switch (71) and remove switch from cover.

Installation

1. Install new ON/OFF switch (71) so tabs of switch snap into place on inside of cover.
2. Connect ON/OFF switch connector (B) to PC board.
3. Swing up cover (77) and secure with two screws (91).

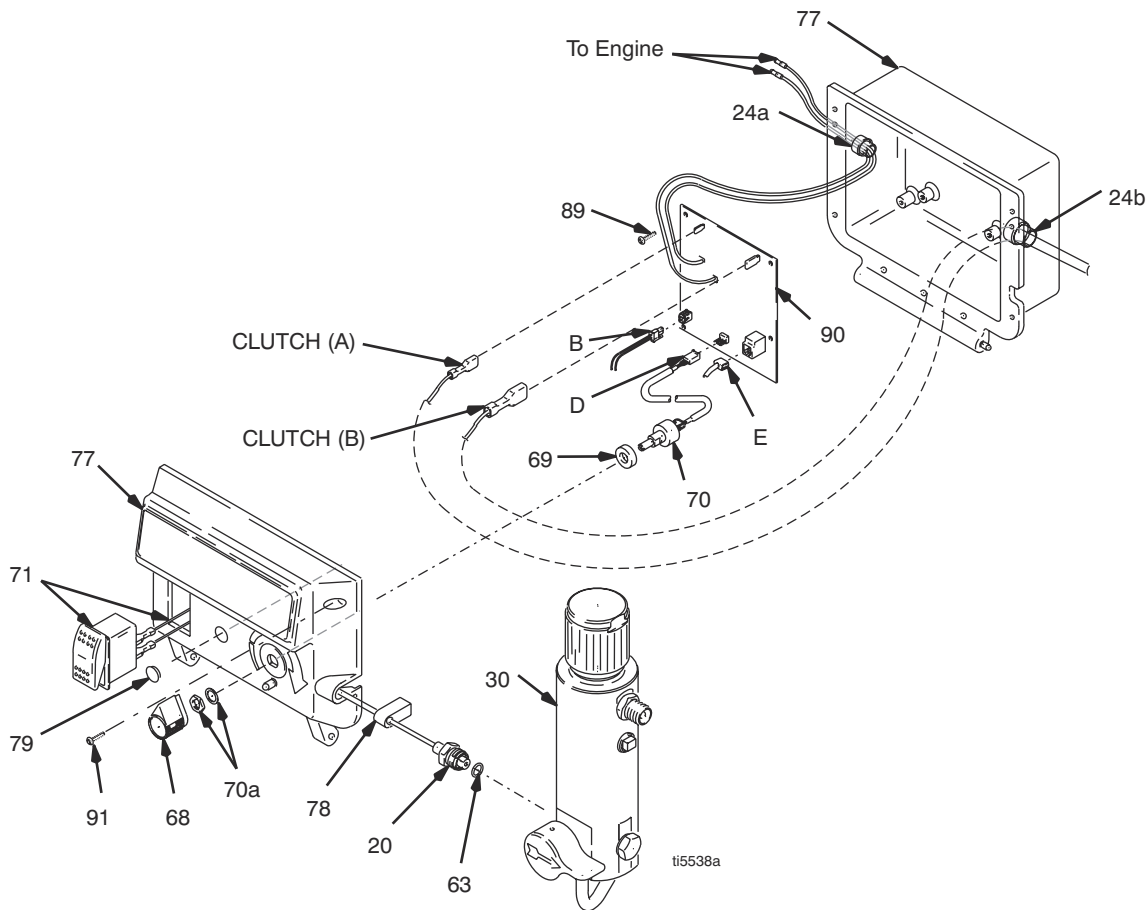
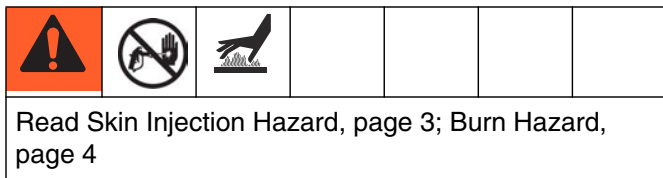

FIG. 13

Control Board

Removal



1. Relieve pressure, page 5.
2. FIG. 13. Remove two screws (91) and swing down cover (77)
3. Remove strain relief bushing (24a).
4. Disconnect engine and ground wires.

5. Disconnect at control board (90):
 - Lead (D) from potentiometer
 - Lead (E) from transducer
 - Lead (B) from ON/OFF switch
 - Clutch wires
6. Remove four screws (89) and control board (90).

Installation

1. FIG. 13. Install control board (90) with four screws (89).
2. Connect at control board (90):
 - Clutch wires
 - Lead (B) from ON/OFF switch
 - Lead (E) from transducer
 - Lead (D) from potentiometer
3. Connect engine and ground wires.
4. Install strain relief bushing (24a).
5. Swing up cover (77) and secure with two screws (91).

Pressure Control Transducer

Removal

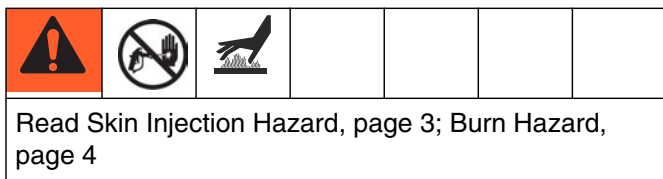

1. Relieve pressure, page 5.
2. FIG. 13. Remove two screws (91) and swing down cover (77)
3. Disconnect lead (E) from control board (90).
4. Pull transducer connector through rubber grommet (78).
5. Remove pressure control transducer (20) and o-ring (63) from filter housing (30).

Installation

1. FIG. 13. Install o-ring (63) and pressure control transducer (20) in filter housing (30). Torque to 35 - 45 ft-lb.
2. Install transducer connector and rubber grommet in control housing.
3. Connect lead (E) to control board (90).
4. Swing up cover (77) and secure with two screws (91).

Pressure Adjust Potentiometer

Removal

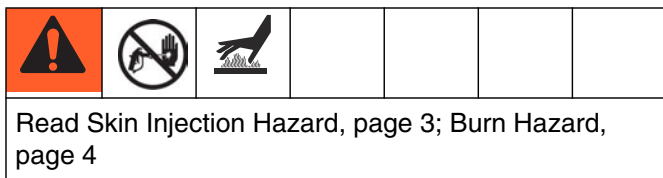

1. Relieve pressure, page 5.
2. Fig. 13. Remove two screws (91) and swing down cover (77).
3. Disconnect lead (D) from control board (90).
4. Loosen set screws on potentiometer knob (68) and remove knob, shaft nut, lock washer and potentiometer (70).
5. Remove seal (69) from potentiometer.



Installation

1. Install seal (69) on potentiometer (70).
2. FIG. 13. Install potentiometer, shaft nut, lock washer and potentiometer knob (68).
 - a. Turn potentiometer shaft clockwise to internal stop. Assemble potentiometer knob (68) to strike pin on cover (77).
 - b. After adjustment of step a., tighten both set screws in knob 1/4 to 3/8 turn after contact with shaft.
3. Connect lead (D) to control board (90).
4. Swing up cover (77) and secure with two screws (91).

Displacement Pump

Removal

1. Flush pump.

						
Read Skin Injection Hazard, page 3; Burn Hazard, page 4						

2. Relieve pressure, page 5.
3. FIG. 15. Stop pump with piston rod (201) in its lowest position.
4. FIG. 14. Loosen two screws (10) and remove pail hook (9).

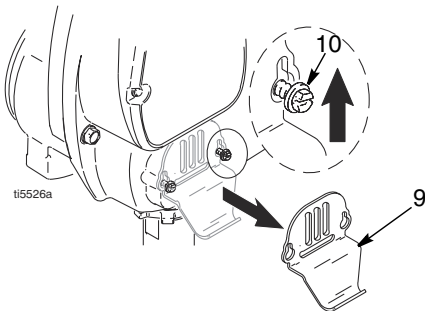

FIG. 14

5. FIG. 15. Remove hose (93). Use screwdriver; push retaining spring up; push out pin (8).

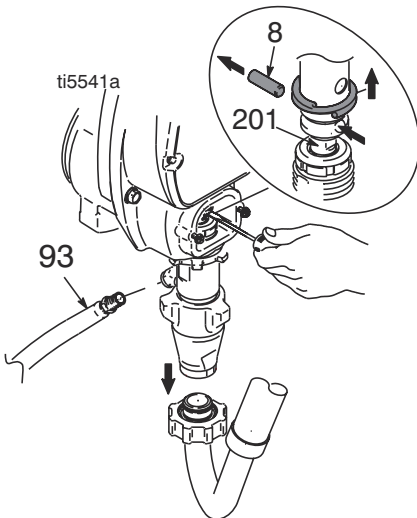

FIG. 15

6. FIG. 16. Loosen jam nut by hitting firmly with a 20 oz hammer. Unscrew pump.

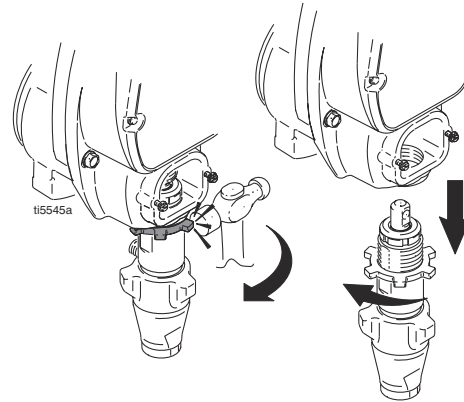

FIG. 16

Repair

See manual 309250 for pump repair instructions

Installation

<p>If pin works loose, parts could break off and project through the air and result in serious injury or property damage. Make sure pin is properly installed.</p>						

NOTICE

- Replacement pump comes with an outlet fitting installed. Replace installed fitting with fitting marked "GMAX 3400".
- If the pump jam nut loosens during operation, the threads of the bearing housing and drive train will be damaged. Tighten jam nut as specified.

1. Fig. FIG. 17. Pull piston rod out. Screw in pump until holes in connecting rod and piston rod align.

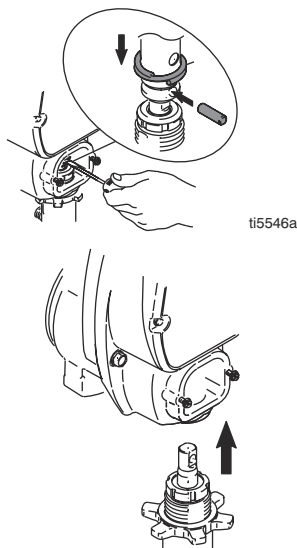

FIG. 17

2. FIG. 11. Push pin (8) into hole. Push retaining ring spring into groove all the way around connecting rod.
3. FIG. 18. Screw jam nut down onto pump until nut stops. Screw pump up into drive housing until top threads of pump are flush with drive housing face (FIG. 19). Back off pump and jam nut to align pump outlet to side. Tighten jam nut by hand, then tap 1/8 to 1/4 turn with a 20 oz (maximum) hammer to approximately 75 ±5 ft-lb (102 N·m). Connect hose (93).

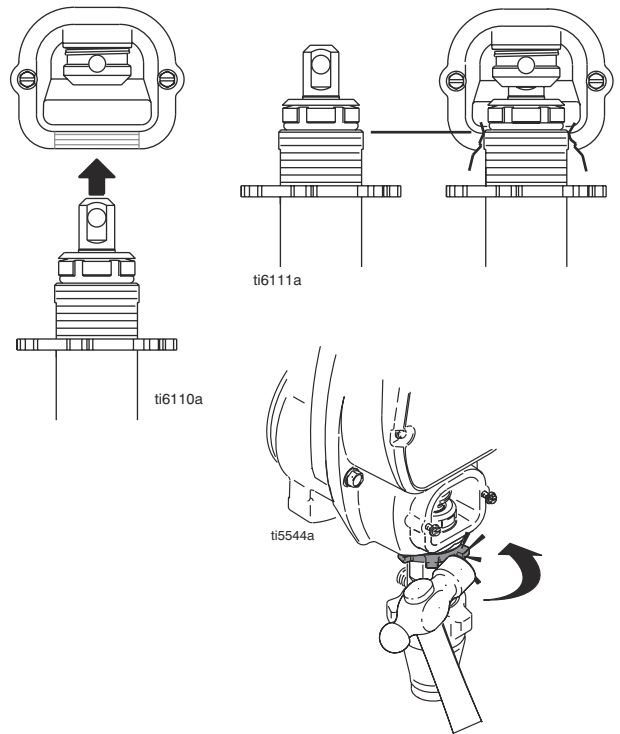
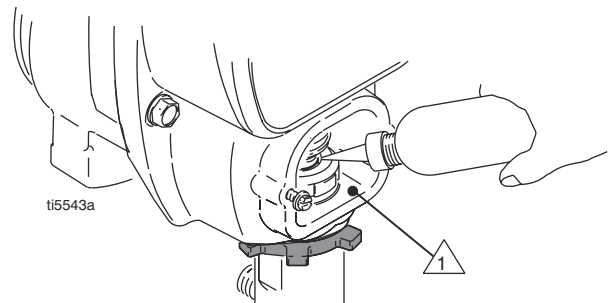

FIG. 18

4. FIG. 19. Fill packing nut with Graco TSL until fluid flows onto the top of seal. Install pail hook (9).



Drive housing face

FIG. 19

Parts

Parts Drawing - GMAX 3400 Hi-Boy Sprayers

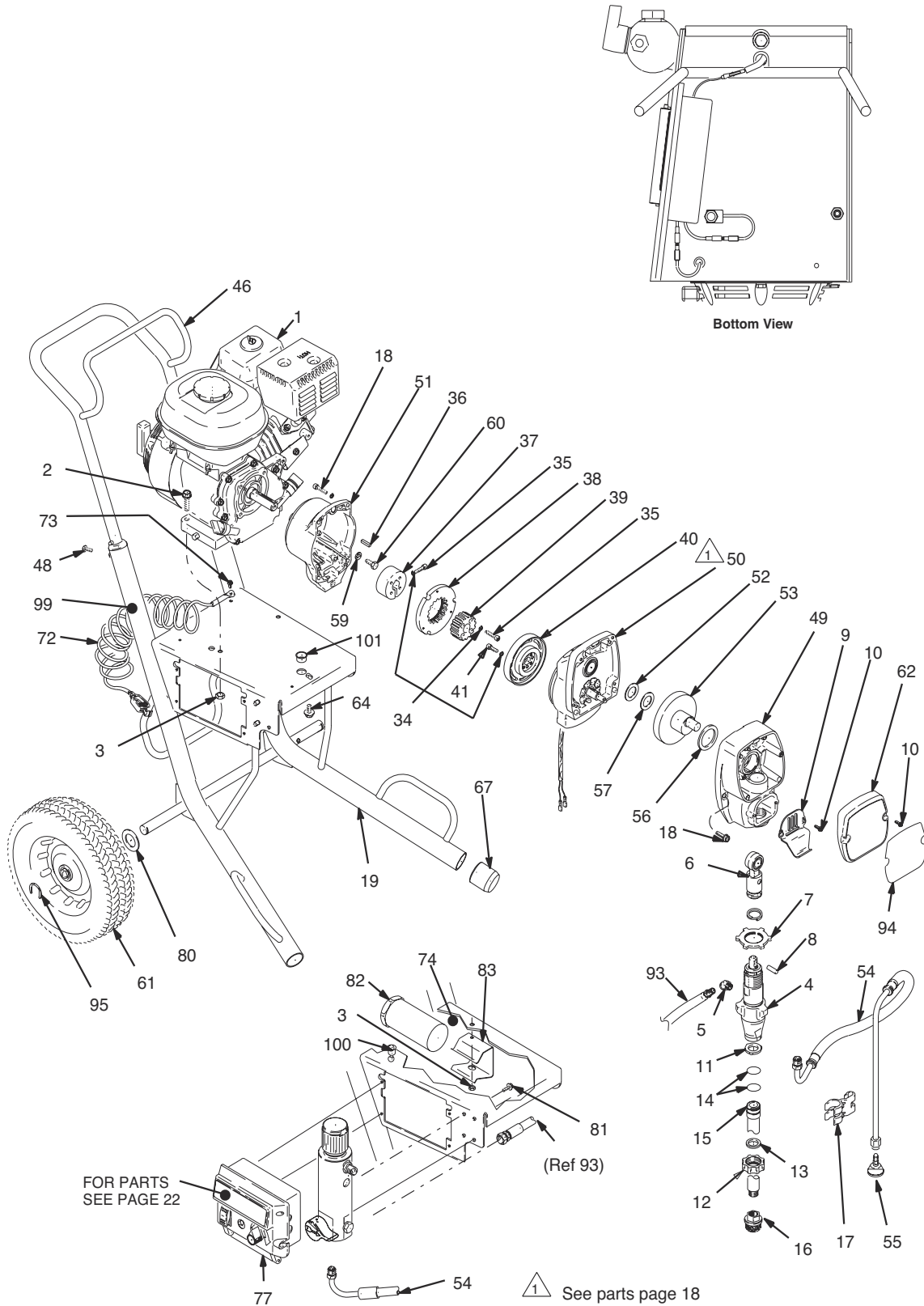

Parts List - GMAX 3400 Hi-Boy Sprayers

Model 248664

Ref. No.	Part No.	Description	Qty.	Ref. No.	Part No.	Description	Qty.
						includes 9, 10, 18 & grease 110293	
1	108879	ENGINE, gasoline, 4.0 HP	1	50	287376	HOUSING, pinion, 3400	1
2	110837	SCREW, flange, hex	2	51	15E535	HOUSING, clutch, mach, 3400	1
3	110838	NUT, lock	2	52	116074	WASHER, thrust	1
4	246428	PUMP, displacement, st Manual 309250	1	53	287484	CRANK, GMAX 3400	1
5	119789	FITTING, elbow, street, 45°, 1/4 npt	2			includes 52, 56, 57	
6	287053	ROD, connecting	1	54	244240	HOSE, coupled, includes 55	1
7	195150	NUT, jam, pump	1	55	241920	DEFLECTOR, threaded	1
8	196762	PIN, straight	1	56	180131	BEARING, thrust	1
9	15C146	HOOK, pail	1	57	107434	BEARING, thrust	1
10	117501	SCREW, mach, hex washer hd	4	59	100214	WASHER, lock	4
11	115099	WASHER, garden hose	1	60	108842	SCREW, cap, hex hd	4
12	15E813	NUT, jam	1	61	119420	WHEEL, pneumatic	2
13	15B652	WASHER, suction	1	62	287487	COVER, front, painted, includes 10	1
14	103413	O-RING	2	64	112395	SCREW, cap, flnghd	1
15	15E805	TUBE, intake (3400)	1	67	15C871	CAP, leg	2
16	246385	STRAINER, 7/8-14 unf	1	72	237686	WIRE, ground assembly w/clamp	1
17	276888	CLIP, drain line	1	73	112798	SCREW, thread forming, hex hd	1
18	119426	SCREW, mach, hex washer hd	8	80	156306	WASHER, flat	2
19	287411	FRAME, cart (GMAX 3400 hi)	1	82	119510	HOLDER, manual	1
34	105510*	WASHER, lock, spring (hi-collar)	10	83	15E736	BRACKET, holder, manual	1
35	108803	SCREW, hex, socket head	6	93	241926	HOSE, coupled	1
36	183401	KEY, parallel	1	94	15E850	LABEL, identification	1
37	193680	COLLAR, shaft	1	95	15E891	CLIP, retaining	2
38	*	ARMATURE, clutch, 4 in.	1	99▲	15F638	LABEL, warning	1
39	*	HUB, armature	1	100	114678	BUSHING, strain relief	1
40	*	ROTOR, clutch, 4 in.	1	101	119569	BUSHING, strain relief	1
41	101682*	SCREW, cap, sch	4				
46	287489	HANDLE, cart	1				
48	109032	SCREW, mach, pnh	4				
49	287483	HOUSING, drive, 3400	1				

▲ Replacement Danger and Warning labels, tags, and cards are available at no cost

* Included in Clutch Replacement Kit 241109

Parts Drawing and List - Pinion Housing

Ref No. 50: Pinion Housing

No.	Part No.	Description	Qty
50		PINION HOUSING	1
50a	287482	KIT, repair, coil	1
50b	105489	PIN	2
50c*	287485	PINION SHAFT	1
50d*	113094	RETAINING RING, large	1

* May be ordered separately

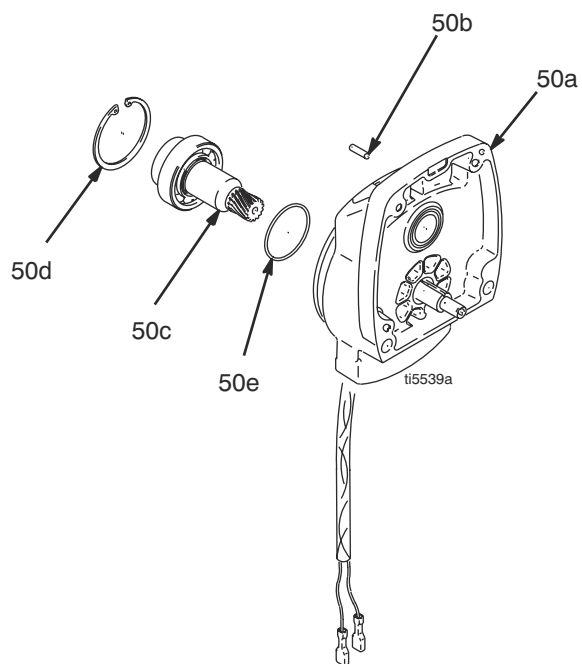

Parts Drawing - GMAX 3400 Lo-Boy Sprayers

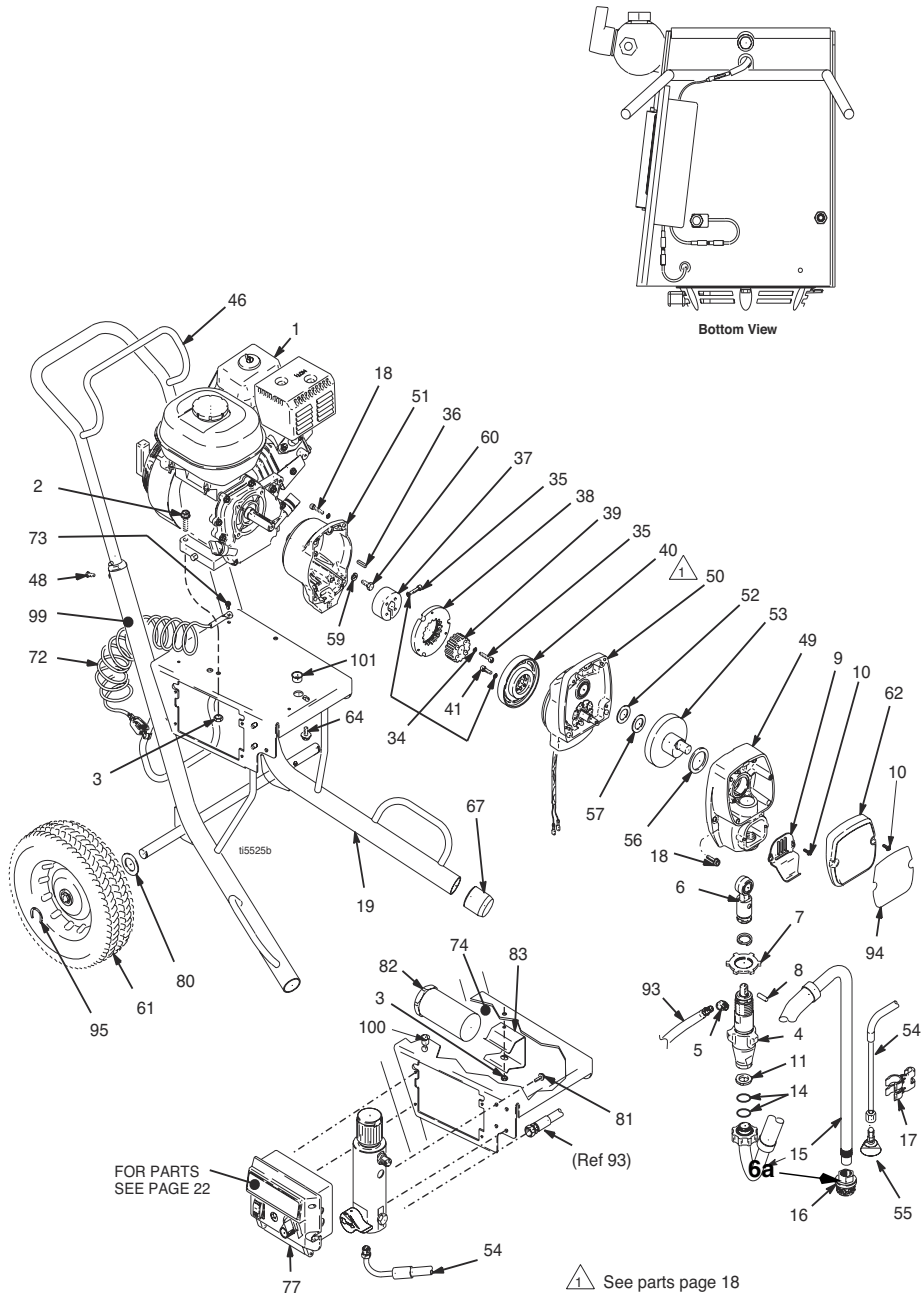

Parts List - GMAX 3400 Lo-Boy Sprayers

Model 248666

Ref				Ref			
No.	Part No.	Description	Qty	No.	Part No.	Description	Qty
						includes 9, 10, 18 & grease 110293	
1	108879	ENGINE, gasoline, 4.0 HP	1	50	287376	HOUSING, pinion, 3400	1
2	110837	SCREW, flange, hex	2	51	15E535	HOUSING, clutch, mach, 3400	1
3	110838	NUT, LOCK	2	52	116074	WASHER, thrust	1
4	246428	PUMP, displacement, st Manual 309250	1	53	287484	CRANK, GMAX 3400	1
5	119789	FITTING, elbow, street, 45°, 1/4 npt	2	54†	244240	HOSE, coupled, includes 55	1
6	287053	ROD, connecting; includes 6a, 8	1	55†	241920	DEFLECTOR, threaded	1
6a	196750	RING, retaining	1	56	180131	BEARING, thrust	1
7	195150	NUT, jam, pump	1	57	107434	BEARING, thrust	1
8	196762	PIN, straight	1	59	100214	WASHER, lock	4
9	15C146	HOOK, pail	1	60	108842	SCREW, cap, hex hd	4
10	117501	SCREW, mach, hex washer hd	4	61	119420	WHEEL, pneumatic	2
11†	115099	WASHER, garden hose	1	62	287487	COVER, front, painted, includes 10	1
12	15E813	NUT, jam	1	64	112395	SCREW, cap, flng hd	1
14†	103413	PACKING, o-ring	2	67	15C871	CAP, leg	2
15†	287416	HOSE, suction	1	72	237686	WIRE, gnd assy w/clamp	1
16†	246385	STRAINER, 7/8-14 unf	1	73	112798	SCREW, thread forming, hex hd	1
17†	276888	CLIP, drain line	1	80	156306	WASHER, flat	2
18	119426	SCREW, mach, hex washer hd	8	82	119510	HOLDER, manual	1
19	287411	FRAME, cart (GMAX 3400 Hi)	1	83	15E736	BRACKET, holder, manual	1
34	105510*	WASHER, lock, spring (hi-collar)	10	93	241926	HOSE, coupled	1
35	108803	SCREW, hex, socket head	6	94	15E850	LABEL, identification	1
36	183401	KEY, parallel	1	95	15E891	CLIP, retaining	2
37	193680	COLLAR, shaft	1	99▲	15F638	LABEL, warning	1
38	*	ARMATURE, clutch, 4 in.	1	100	114678	BUSHING, strain relief	1
39	*	HUB, armature	1	101	119569	BUSHING, strain relief	1
40	*	ROTOR, clutch, 4 in.	1				
41	101682*	SCREW, cap, sch	4				
46	287489	HANDLE, cart	1				
48	109032	SCREW, mach, pnh	4				
49	287483	HOUSING, drive, 3400	1				

▲ Replacement Danger and Warning labels, tags, and cards are available at no cost

* Included in Clutch Replacement Kit 241109

† Included in Suction Hose Kit 249356

Pressure Control/Filter Assembly

GMAX 3400 Sprayers

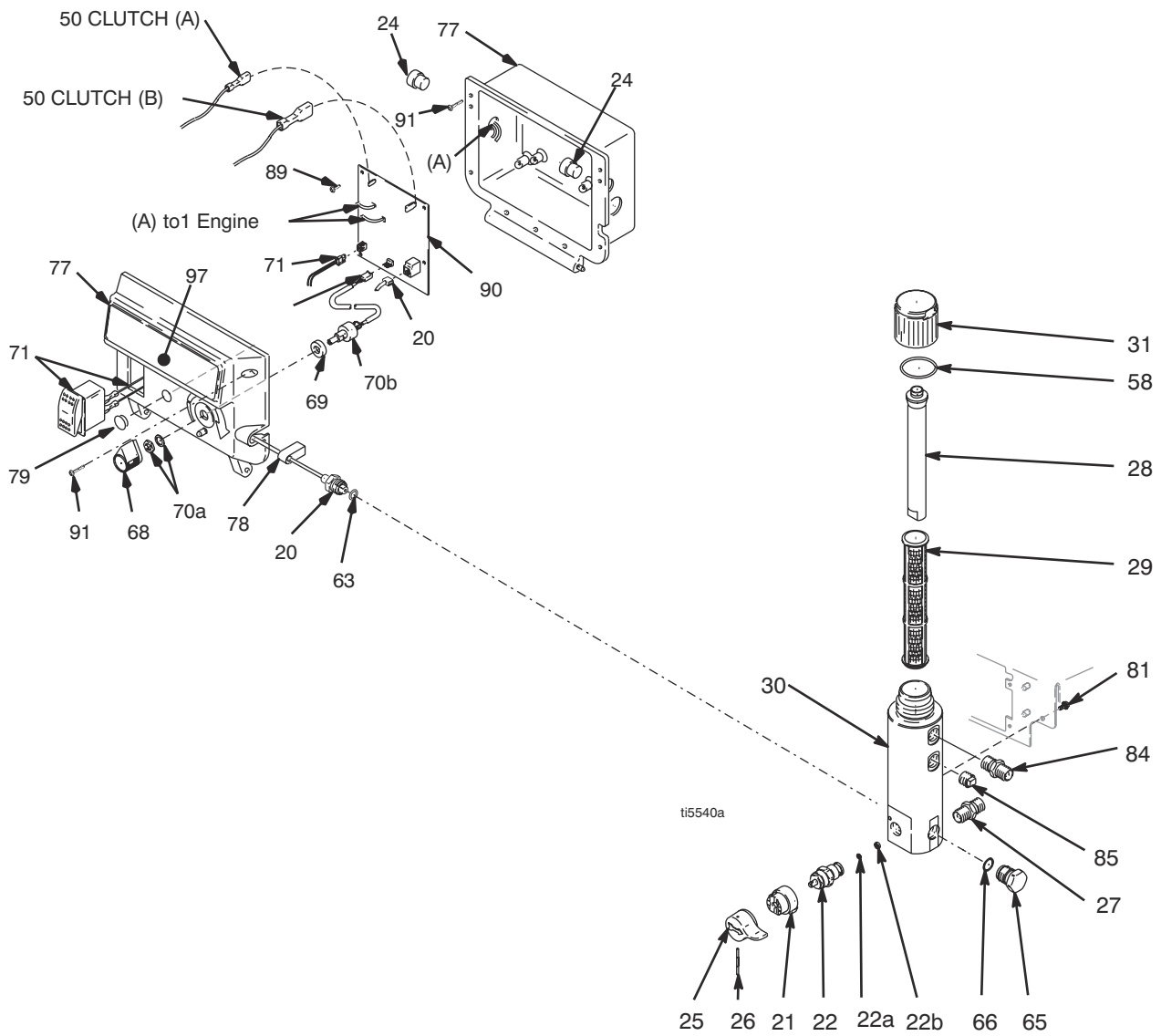

Pressure Control/Filter Assembly

GMAX 3400 Sprayers

Ref.	Part	Description	Qty.	Ref.	Part	Description	Qty.
20	243222	TRANSDUCER, pressure contl includes 63	1	65	248314	PLUG, auto clean, includes 66	1
21	224807	BASE, valve	1	66	15D541	SEAL, washer	1
22	235014	VALVE, drain; includes 22a, 22b	1	68	116167	KNOB, potentiometer	1
24	119545	BUSHING, strain, relief	2	69	198650	SPACER, shaft	1
25	15C780	HANDLE,	1	70	241443	POTENTIOMETER; includes 70a, 70b	1
26	15C972	PIN, grooved	1	71	116752	SWITCH, rocker	1
27	164672	NIPPLE, adapter	1	77	249357	BOX, control includes 68, 69, 70, 71, 79, 89, 90, 97	1
28	15C766	TUBE, diffusion	1	78	15E925	GASKET, transducer	1
29		FILTER, fluid		79	119548	PLUG, cap	1
	244071	30 mesh	1	81	113161	SCREW, flange, hex hd	3
	244067	60 mesh, original equipment	1	84	164672	ADAPTER	1
	244068	100 mesh	1	85	104813	PLUG, pipe	1
	244069	200 mesh	1	89	117317	SCREW, plastite, pan head	4
30	15E284	HOUSING, filter	1	90	287486	CONTROL, board, 3400	1
31	287285	CAP, filter, includes 28, 58	1	91	116585	SCREW, mach, pan hd	6
58	117285	O-RING	1	97	15E856	LABEL, identification	1
63	111457	O-RING	1				

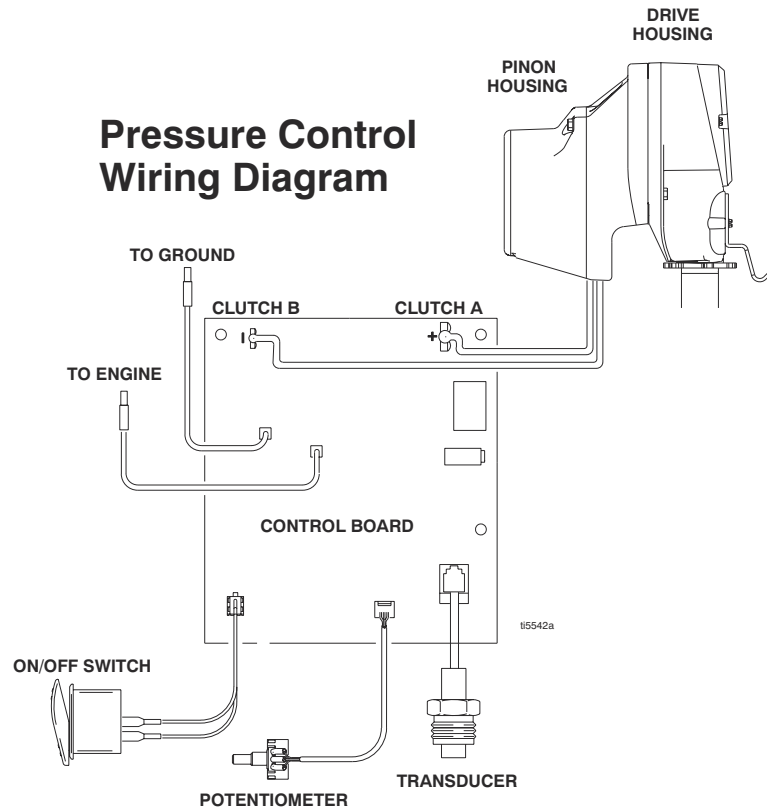

Complete Sprayers - with RAC X Tip, Gun & Hose

GMAX 3400 Airless Paint Sprayers
Includes items 201 to 204

Ref No.	Part No.	Description	Qty
201	248664	Hi-Boy Sprayer See parts list on page 17	1
	248666	Lo-Boy Sprayer See parts list on page 21	1
202	240794	HOSE, grounded, nylon; 1/4 in. ID; cpld 1/4 npsm(fbe); 50 ft (15 m); spring guards both ends 3300 psi (227 bar, 27.7 MPa)	1
203	238358	HOSE, grounded, nylon; 3/16 in. ID; cpld 1/4 npsm(m) x 1/4 npsm(f) swivel; 3 ft (0.9 m); spring guards both ends	1
204	288420	CONTRACTOR II SPRAY GUN Includes RAC X 517-size SwitchTip and HandTite Guard See 311861 for parts	1

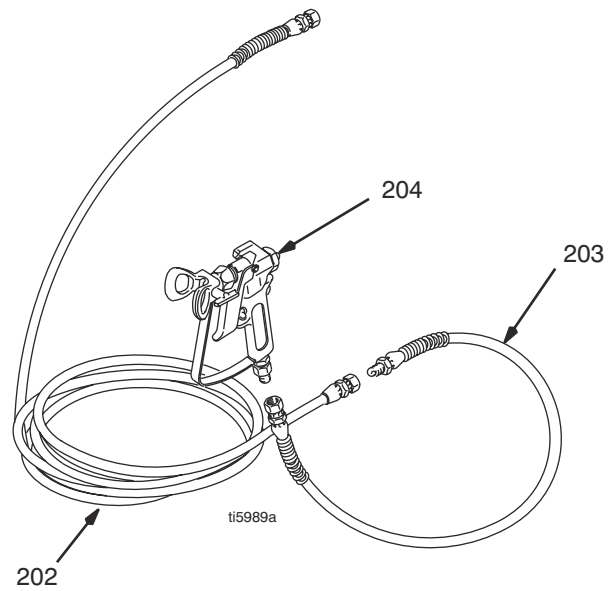

Technical Data

Honda GX120 Engine	
ANSI Power Rating @ 3600 rpm	4.0 Horsepower (2.9 kW)
Maximum working pressure	3300 psi (227 bar, 22.7 MPa)
Noise Level	
Sound power	100 dBa per ISO 3744
Sound pressure	86 dBa measured at 3.1 feet (1 m)
Maximum delivery rating	0.75 gpm (2.84 liter/min)
Maximum tip size	1 gun with 0.027 in. tip
Inlet paint strainer	12 mesh (893 micron) stainless steel screen, reusable
Outlet paint filter	60 mesh (250 micron) stainless steel screen, reusable
Pump inlet size	1¼-12 unf-2b
Fluid outlet size	¼ npsm from fluid filter
Wetted parts	zinc-plated carbon steel, PTFE, Nylon, polyurethane, UHMW polyethylene, fluoro- elastomer, acetal, leather, aluminum, tungsten carbide, nickel- and zinc-plated carbon steel, stainless steel, chrome plating

Dimensions

Sprayer (without hose and gun)	Weight lb (kg)	Height in. (cm)	Width in. (cm)	Length in. (cm)
248664 Hi-Boy	89 (40.4)	31.5 (80)	22.5 (58)	31 (79)
248666 Lo-Boy	89 (40.4)	31.5 (80)	22.5 (58)	31 (79)

Graco Standard Warranty

Graco warrants all equipment referenced in this document which is manufactured by Graco and bearing its name to be free from defects in material and workmanship on the date of sale to the original purchaser for use. With the exception of any special, extended, or limited warranty published by Graco, Graco will, for a period of twelve months from the date of sale, repair or replace any part of the equipment determined by Graco to be defective. This warranty applies only when the equipment is installed, operated and maintained in accordance with Graco's written recommendations.

This warranty does not cover, and Graco shall not be liable for general wear and tear, or any malfunction, damage or wear caused by faulty installation, misapplication, abrasion, corrosion, inadequate or improper maintenance, negligence, accident, tampering, or substitution of non-Graco component parts. Nor shall Graco be liable for malfunction, damage or wear caused by the incompatibility of Graco equipment with structures, accessories, equipment or materials not supplied by Graco, or the improper design, manufacture, installation, operation or maintenance of structures, accessories, equipment or materials not supplied by Graco.

This warranty is conditioned upon the prepaid return of the equipment claimed to be defective to an authorized Graco distributor for verification of the claimed defect. If the claimed defect is verified, Graco will repair or replace free of charge any defective parts. The equipment will be returned to the original purchaser transportation prepaid. If inspection of the equipment does not disclose any defect in material or workmanship, repairs will be made at a reasonable charge, which charges may include the costs of parts, labor, and transportation.

Graco's sole obligation and buyer's sole remedy for any breach of warranty shall be as set forth above. The buyer agrees that no other remedy (including, but not limited to, incidental or consequential damages for lost profits, lost sales, injury to person or property, or any other incidental or consequential loss) shall be available. Any action for breach of warranty must be brought within two (2) years of the date of sale.

GRACO MAKES NO WARRANTY, AND DISCLAIMS ALL IMPLIED WARRANTIES OF MERCHANTABILITY AND FITNESS FOR A PARTICULAR PURPOSE, IN CONNECTION WITH ACCESSORIES, EQUIPMENT, MATERIALS OR COMPONENTS SOLD BUT NOT MANUFACTURED BY GRACO. These items sold, but not manufactured by Graco (such as electric motors, switches, hose, etc.), are subject to the warranty, if any, of their manufacturer. Graco will provide purchaser with reasonable assistance in making any claim for breach of these warranties.

In no event will Graco be liable for indirect, incidental, special or consequential damages resulting from Graco supplying equipment hereunder, or the furnishing, performance, or use of any products or other goods sold hereto, whether due to a breach of contract, breach of warranty, the negligence of Graco, or otherwise.

FOR GRACO CANADA CUSTOMERS

The Parties acknowledge that they have required that the present document, as well as all documents, notices and legal proceedings entered into, given or instituted pursuant hereto or relating directly or indirectly hereto, be drawn up in English. Les parties reconnaissent avoir convenu que la rédaction du présente document sera en Anglais, ainsi que tous documents, avis et procédures judiciaires exécutés, donnés ou intentés, à la suite de ou en rapport, directement ou indirectement, avec les procédures concernées.

ADDITIONAL WARRANTY COVERAGE

Graco does provide extended warranty and wear warranty for products described in the Graco Contractor Equipment Warranty Program.

Graco Information

For the latest information about Graco products, visit www.graco.com.

TO PLACE AN ORDER, contact your Graco distributor or call 1-800-690-2894 to identify the nearest distributor.

*All written and visual data contained in this document reflects the latest product information available at the time of publication.
Graco reserves the right to make changes at any time without notice.*

Original instructions. This manual contains English. MM 310813

Graco Headquarters: Minneapolis

International Offices: Belgium, China, Japan, Korea

GRACO INC. AND SUBSIDIARIES • P.O. BOX 1441 • MINNEAPOLIS MN 55440-1441 • USA

Copyright 2005, Graco Inc. All Graco manufacturing locations are registered to ISO 9001.

www.graco.com
Revised 07/2011