

# TITAN™

## High Performance Airless Sprayer

**Models: XT250  
XT290  
XT330**

### Owner's Manual

Read this manual for complete instructions

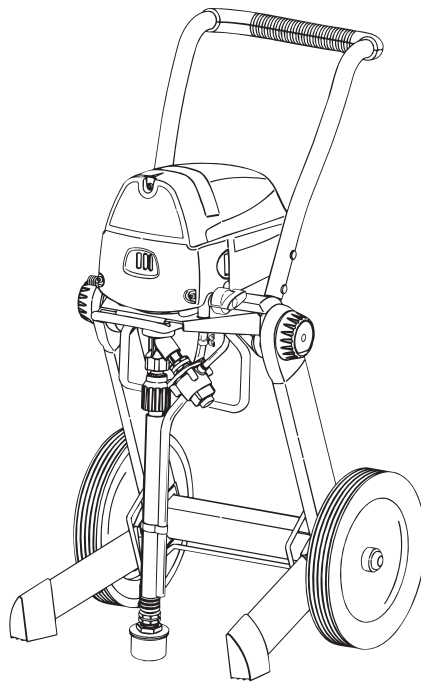
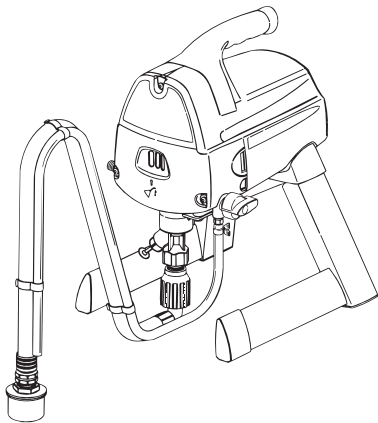

This pump is available in a stand model (XT250) and cart models (XT290 and XT330). All information given for the stand model applies to the cart models except where indicated.

### Table of Contents

Safety.....	2-3
Components and Description .....	4-5
Assembly.....	6
Before You Begin .....	7
Locking the Spray Gun.....	7
Pressure Relief Procedure .....	7
Grounding the Spray Gun .....	7
Preparing the Sprayer .....	8
Preparing the Spray Hose.....	9
Practice / Spraying Technique .....	10
Spraying Troubleshooting.....	11-12
Unclogging the Spray Tip .....	11
Cleaning the Spray Gun Filter .....	12
Cleaning the Inlet Filter .....	12
Cleanup .....	13-17
Cleanup for Latex materials .....	13-14
Cleanup for Oil-based materials.....	15
Cleaning the Suction Set.....	16
Cleaning the Spray Gun Components.....	17
Short-Term Storage.....	18
Long-Term Storage .....	19
Cleaning the Inlet Valve .....	20
Fluid Section.....	21
Troubleshooting / Maintenance .....	22
Français.....	23
Parts List.....	45-47
Accessories .....	47
Warranty.....	48



**1-866-Titan XT**  
(1-866-848-2698)

**Titan Technical Service**

Visit us on the world wide web!

[www.titan-xt.com](http://www.titan-xt.com)

1770 Fernbrook Lane, Plymouth, MN 55447

**Need Help? Call us first for answers**

**fast.** Call Titan toll-free if you have any comments or problems with this product.

**Technical service hours: Monday through Friday, 8:00 am to 7:00 pm Central Time  
Saturday, 9:00 am to 3:30 Central Time**



# Important Safety Information • Read all safety information before operating the equipment. SAVE THESE INSTRUCTIONS.

To reduce the risks of fire or explosion, electrical shock and the injury to persons, read and understand all instructions included in this manual. Be familiar with the controls and proper usage of the equipment.



This symbol indicates a hazardous situation, which, if not not avoided could result in death or serious injury.

## HAZARD: INJECTION INJURY

A high pressure paint stream produced by this equipment can pierce the skin and underlying tissues, leading to serious injury and possible amputation. See a physician immediately.



**DO NOT TREAT AN INJECTION INJURY AS A SIMPLE CUT! Injection can lead to amputation. See a physician immediately.**

The maximum operating range of the gun is 3000 PSI/207 BAR fluid pressure.

### PREVENTION:

- NEVER aim the gun at any part of the body.
- Do not aim the gun at, or spray any person or animal.
- NEVER allow any part of the body to touch the fluid stream. DO NOT allow body to touch a leak in the fluid hose.
- NEVER put your hand in front of the gun. Gloves will not provide protection against an injection injury.
- ALWAYS lock the gun trigger, shut the pump off, and release all pressure before servicing, cleaning the tip or guard, changing tip, or leaving unattended. Pressure will not be released by turning off the motor. The PRIME/SPRAY knob must be turned to PRIME to relieve the pressure. Refer to the **Pressure Relief Procedure** (page 7) described in the pump manual.
- ALWAYS keep the tip guard in place while spraying. The tip guard provides some protection but is mainly a warning device.
- ALWAYS remove the spray tip before flushing or cleaning the system.
- Paint hose can develop leaks from wear, kinking and abuse. A leak can inject material into the skin. Inspect the hose before each use. Do not use hose to lift or pull equipment.
- NEVER use a spray gun without a working trigger lock and trigger guard in place.
- All accessories must be rated at or above 3000 PSI/207 BAR. This includes spray tips, guns, extensions, and hose.

### NOTE TO PHYSICIAN:

Injection into the skin is a traumatic injury. It is important to treat the injury as soon as possible. DO NOT delay treatment to research toxicity. Toxicity is a concern with some coatings injected directly into the blood stream. Consultation with a plastic surgeon or reconstructive hand surgeon may be advisable.

## HAZARD: HAZARDOUS VAPORS

Paints, solvents, insecticides, and other materials can be harmful if inhaled or come in contact with the body. Vapors can cause severe nausea, fainting, or poisoning.



### PREVENTION:

- Use a respirator or mask if vapors can be inhaled. Read all instructions supplied with the mask to be sure it will provide the necessary protection.
- Wear protective eyewear.
- Wear protective clothing as required by coating manufacturer.



## HAZARD: EXPLOSION OR FIRE

Solvent and paint fumes can explode or ignite. Property damage and/or severe injury can occur.



### PREVENTION:

- Provide extensive exhaust and fresh air introduction to keep the air within the spray area free from accumulation of flammable vapors. Solvent and paint fumes can explode or ignite.
- Do not spray in a confined area.
- Avoid all ignition sources such as static electric sparks, open flames, pilot lights, electrical appliances, and hot objects. Connecting or disconnecting power cords or working light switches can make sparks. Paint or solvent flowing through the equipment is able to result in static electricity.
- Do not smoke in spray area.
- Fire extinguisher must be present and in good working order.
- Place pump at least 20 feet (6.1 meters) from the spray object in a well ventilated area (add more hose if necessary). Flammable vapors are often heavier than air. Floor area must be extremely well ventilated. The pump contains arcing parts that emit sparks and can ignite vapors.
- The equipment and objects in and around the spray area must be properly grounded to prevent static sparks.
- Keep area clean and free of paint or solvent containers, rags and other flammable materials.
- Use only conductive or grounded high pressure fluid hose. Gun must be grounded through hose connections.
- Power cord must be connected to a grounded circuit.
- Always flush unit into a separate metal container, at low pump pressure, with spray tip removed. Hold gun firmly against side of container to ground container and prevent static sparks.
- Follow the material and solvent manufacturer's warnings and instructions. Know the contents of the paints and solvents being sprayed. Read all Material Safety Data Sheets (MSDS) and container labels provided with the paints and solvents. Follow the paint and solvent manufacturer's safety instructions.
- Use extreme caution when using materials with a flashpoint below 70°F (21°C). Flashpoint is the temperature that a fluid can produce enough vapors to ignite.
- Plastic can cause static sparks. Never hang plastic to enclose a spray area. Do not use plastic drop cloths when spraying flammable materials.
- Use lowest possible pressure to flush equipment.
- Do not spray onto pump assembly.



## HAZARD: EXPLOSION HAZARD DUE TO INCOMPATIBLE MATERIALS

Will cause property damage or severe injury.



### PREVENTION:

- Do not use materials containing bleach or chlorine.
- Do not use halogenated hydrocarbon solvents such as bleach, mildewcide, methylene chloride and 1,1,1 - trichloroethane. They are not compatible with aluminum.
- Contact your coating supplier about the compatibility of material with aluminum.



# Important Safety Information • Read all safety information before operating the equipment. SAVE THESE INSTRUCTIONS.

## HAZARD: GENERAL

Can cause severe injury or property damage.

### PREVENTION:

- Read all instructions and safety precautions before operating equipment.
- Follow all appropriate local, state, and national codes governing ventilation, fire prevention, and operation.
- The United States Government Safety Standards have been adopted under the Occupational Safety and Health Act (OSHA). These standards, particularly part 1910 of the General Standards and part 1926 of the Construction Standards should be consulted.
- Use only manufacturer authorized parts. User assumes all risks and liabilities when using parts that do not meet the minimum specifications and safety requirements of the pump manufacturer.
- Before each use, check all hoses for cuts, leaks, abrasion or bulging of cover. Check for damage or movement of couplings. Immediately replace the hose if any of these conditions exist. Never repair a paint hose. Replace it with another grounded high-pressure hose.
- All hoses and fittings must be secured before operating spray pump. Unsecured parts can eject at great force or leak a high pressure fluid stream causing severe injury.
- All hoses, swivels, guns, and accessories must be pressure rated at or above 3000 PSI/207 BAR.
- Do not spray outdoors on windy days.
- Wear clothing to keep paint off skin and hair.
- Do not operate or spray near children. Keep children away from the equipment at all times.
- Do not overreach or stand on an unstable support. Keep effective footing and balance at all times.
- Stay alert and watch what you are doing.
- Do not operate the unit when fatigued or under the influence of drugs or alcohol.

## Important Electrical Information

**NOTICE** - Use only a 3-wire extension cord that has a 3-blade grounding plug and a 3-slot receptacle that will accept the plug on the product. Make sure your extension cord is in good condition. When using an extension cord, be sure to use one heavy enough to carry the current your product will draw. An undersized cord will cause a drop in line voltage resulting in loss of power and overheating. A 14 or 12 gauge cord is recommended (see chart below). If an extension cord is to be used outdoors, it must be marked with the suffix W-A after the cord type designation. For example, a designation of SJTW-A would indicate that the cord would be appropriate for outdoor use.

Cord gauge	Maximum cord length
12	150 feet
14	100 feet

**Do not use more than 100 feet of spray hose. If you need to spray further than 100 feet from your power source, use more extension cord, not more spray hose.**

**NOTE - THE XT250 AND XT290 SERIES UNITS ARE PROVIDED WITH A NON-RESETABLE THERMAL OVERLOAD. THE XT330 SERIES UNIT IS PROVIDED WITH A REPLACEABLE FUSE.**

- Always disconnect the motor from the power supply before working on the equipment.

**The cause of the overload should be corrected before restarting. Take to Service Center.**

## Grounding Instructions

This product must be grounded. In the event of an electrical short circuit, grounding reduces the risk of electric shock by providing an escape wire for the electric current. This product is equipped with a cord having a grounding wire with an appropriate grounding plug. The plug must be plugged into an outlet that is properly installed and grounded in accordance with all local codes and ordinances.

**WARNING - Improper installation of the grounding plug can result in a risk of electric shock.**



If repair or replacement of the cord or plug is necessary, do not connect the green grounding wire to either flat blade terminal. The wire with insulation having a green outer surface with or without yellow stripes is the grounding wire and must be connected to the grounding pin.

Check with a qualified electrician or serviceman if the grounding instructions are not completely understood, or if you are in doubt as to whether the product is properly grounded. Do not modify the plug provided. If the plug will not fit the outlet, have the proper outlet installed by a qualified electrician.

This product is for use on a nominal 120 volt circuit and has a grounding plug that looks like the plug illustrated below. Make sure that the product is connected to an outlet having the same configuration as the plug. **No adapter should be used with this product.**

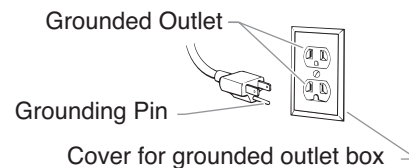

**If you experience problems with your sprayer at any time during assembly, operation, or cleanup, please refer to the Troubleshooting section of this manual (page 22), or call customer service at:**

**1-866-Titan XT  
(1-866-848-2698)**

# Components and Description

## Components

The shipping carton for your painting system contains the following:

- Suction tube and return tube
- Pump cleaning adapter
- Spray gun with filter
- Spray tip assembly (see chart on next page)
- 25' (XT250, XT290) or 50' (XT330), 1/4" diameter pressure hose
- Instruction manual

## Tools Needed for Assembly

- Two adjustable wrenches
- Extension cord (refer to **Important Electrical Information**, page 3).

## Controls and Functions

- ON/OFF Switch** ..... The ON/OFF switch turns the power to the sprayer on and off (O=OFF, I=ON).
- Suction tube** ..... Fluid is drawn through the suction tube into the pump.
- Fluid Section** ..... A piston in the fluid section moves up and down to create the suction that draws fluid through the suction tube.
- Spray Gun** ..... The spray gun controls the delivery of the fluid being pumped. The gun model you have depends on your sprayer model (refer to **Spray Gun/Tip Chart**, next page).
- Spray Hose** ..... The spray hose connects the gun to the pump.
- Return Tube** ..... Fluid is sent back out through the return tube to the original container when PRIME/SPRAY knob is in PRIME position.
- Pump Cleaning Adapter** ..... The adapter allows you to attach a garden hose to the suction tube for easy cleanup (latex materials only).
- PRIME/SPRAY Knob** ..... The PRIME/SPRAY knob directs fluid to the spray hose when set to SPRAY or the return tube when set to PRIME. The arrows on the PRIME/SPRAY knob shows the rotation directions for PRIME and SPRAY.  
The PRIME/SPRAY knob is also used to relieve pressure built up in the spray hose (see **Pressure Relief Procedure**, page 7).
- PressureTrac™** ..... The PressureTrac™ regulates the amount of force the pump uses to push the fluid.
- Quickflo™ valve** ..... **(XT250 only)** The Quickflo™ valve is designed to keep the inlet valve open and from sticking to dried materials. The Quickflo™ valve is activated manually by the user.
- Sureflo™ valve** ..... **(XT290 and XT330 only)** The Sureflo™ valve is designed to keep the inlet valve open and from sticking due to dried materials. The Sureflo™ valve is activated automatically every time you turn the ON/OFF switch ON.

## Specifications

### Capacity:

- XT250 ..... Up to .25 gallon (0.95 liter) / minute  
XT290 ..... Up to .29 gallon (1.1 liters) / minute  
XT330 ..... Up to .33 gallon (1.25 liters) / minute

### Power source:

- XT250 ..... 1/2 Hp universal motor  
XT290 ..... 5/8 Hp universal motor  
XT330 ..... 3/4 Hp permanent magnet DC motor

### Power requirement:

15 amp minimum circuit on 115 VAC, 60 Hz current

### Generator power requirement:

8000 Watt

### Safety features:

Spray gun trigger lock and pressure diffuser; built-in tip safety guard; PRIME/SPRAY knob for safe pressure release.

### Capability:

Sprays a variety of paints, primers, stains, preservatives and other nonabrasive materials, including pesticides and liquid fertilizers.

**This pump should not be used with textured materials, block filler, or asphalt sealer.**

# Components and Description

This pump is available in a stand model (XT250) and cart models (XT290 shown below, and XT330). All information given for the stand model applies to the cart models except where indicated.

## NOTICE

Some of the graphics in this manual may not exactly match your sprayer and spray gun. All information and instructions given in this manual applies to all models except where noted.

Spray Gun/Tip Chart					
Sprayer Model	Gun Model	Tip	Max. Tip	Recommended Gun Filter	Spray hose length
XT250	XT-05	415	415	Yellow (fine)	25 feet
XT290	XT-05	415	415	Yellow (fine)	25 feet
XT330	LX60	517	519	White (medium)	50 feet

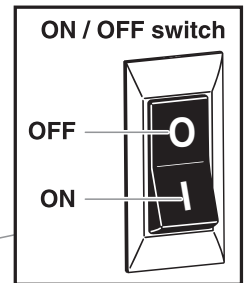
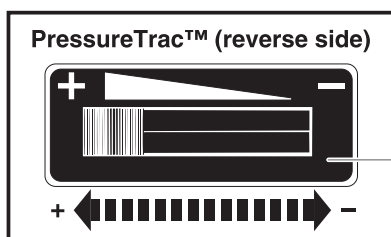

Lubricating area

Spray hose port

Pail bracket

Suction tube

Return tube

Clip

Leg lock (cart models only)

Inlet filter

\*Pump cleaning adapter

PRIME/SPRAY knob

Knob (cart models only)

Return tube fitting

Sureflo™ valve

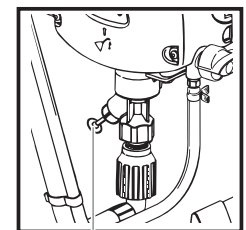

Quickflo™ valve (XT250 only)

Spray hose

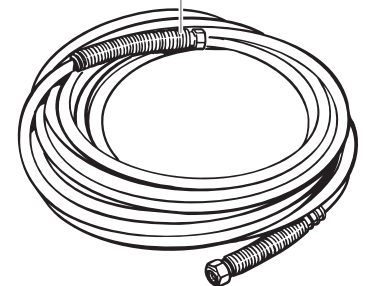

\*The pump cleaning adapter can be clipped to the spray hose port

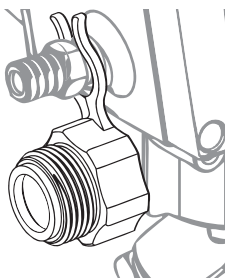

## Spray Gun Assembly

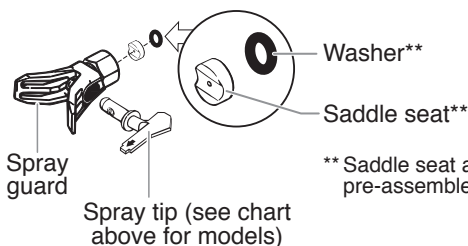

Spray gun (see chart above for models)

(LX60 shown)

\*\* Saddle seat and washer come pre-assembled inside spray guard

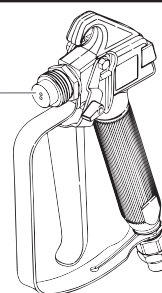

# Assembly



Do not plug in the power cord until assembly is complete.

If you have one of the cart models (XT290 or XT330) you will need to unfold the cart before using. Follow steps 1-3, below. If you have the model XT250 sprayer, skip to item 4, below.

1. Grab the pail bracket to lift up the sprayer. Lift the leg lock and unfold the legs. Move leg lock down to lock into place (inset).

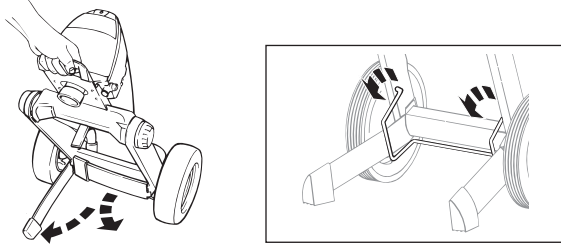

2. Twist the knob on either side of the cart toward the "UP" arrow until it stops.

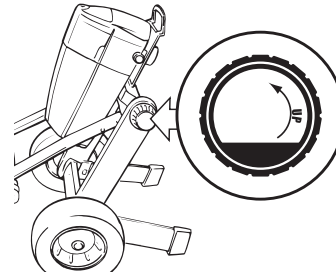

3. Lift the handle until the motor housing and handle locks into place. Be careful not to pinch the power cord with the cart.

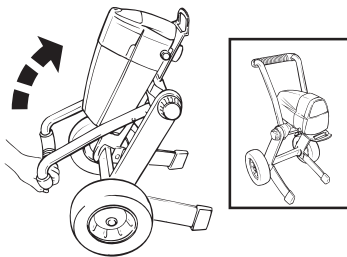

4. Thread one end of the high pressure spray hose to the spray hose port. Hold the port with an adjustable wrench, and tighten the hose with the other.

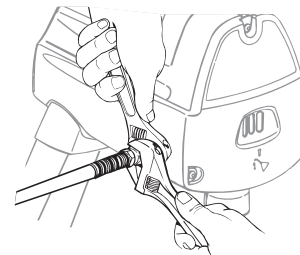

5. Thread the other end of the hose to the spray gun. Hold the gun with one adjustable wrench, and tighten the hose nut with the other.

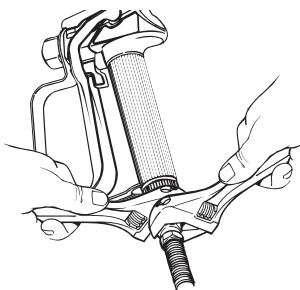

The spray tip should not be attached until after the sprayer and spray hose have been purged and primed.

6. Remove cap from inlet valve (a). Thread the suction tube onto the inlet valve and tighten firmly by hand. Be sure that the threads are straight so that the fitting turns freely.

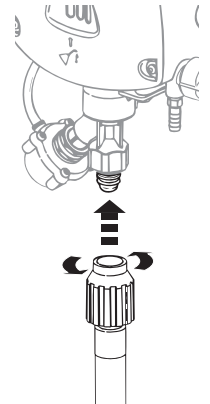
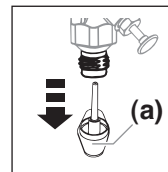

7. Press the return tube onto the return tube fitting. Squeeze clip over the return tube fitting to secure the return tube.

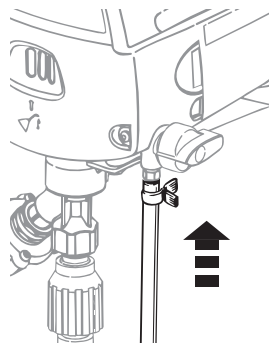

8. Verify that the seal is present inside the suction tube. Thread the inlet filter into the end of the suction tube.

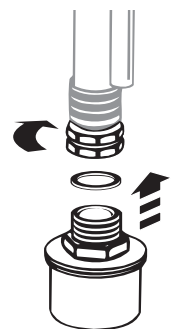

# Before you Begin - This section contains instructions that will be repeated throughout this manual.

## Locking / Unlocking the Spray Gun



Always lock the trigger off when attaching the spray tip or when the spray gun is not in use.

### Model XT-05

The gun is locked when the trigger lock is at a 90° angle (perpendicular to the trigger in either direction).

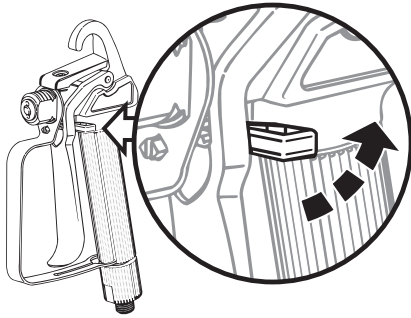

### Model LX60

To lock the gun, turn the trigger lock forward and slightly down until it stops.

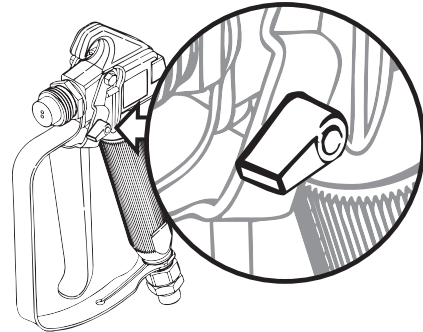

## Pressure Relief Procedure



Be sure to follow the Pressure Relief Procedure when shutting the unit off for any purpose. This procedure is used to relieve pressure from the spray hose.

1. Lock the spray gun off (see directions above). Flip the ON/OFF switch to the OFF position.

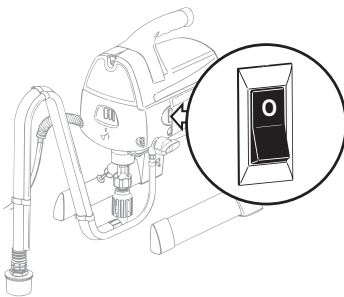

2. Turn the PRIME/SPRAY knob to PRIME.

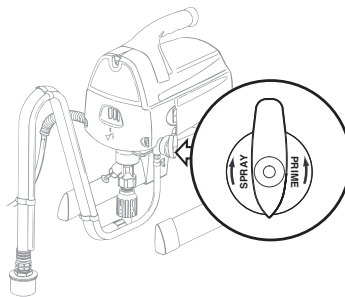

3. Unlock the spray gun and trigger spray gun into the side of the material bucket. Lock the spray gun.

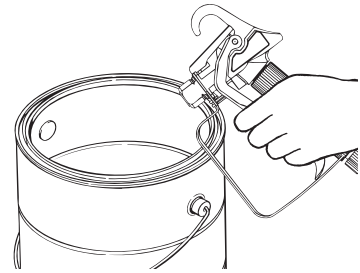

## Grounding the Spray Gun (oil-based materials only)



If spraying or cleaning with oil-based materials, the spray gun must be grounded while preparing the spray hose or cleaning.

Ground the gun by holding it against the edge of a metal container while purging. Failure to do so may lead to a static electric discharge which may cause a fire.

Keep hands clear of the fluid stream.

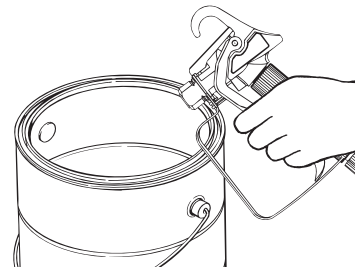

# Preparing the Sprayer

All new units are performance-tested at the factory and are shipped with test fluid in the fluid section to prevent corrosion during shipment and storage. If you have already used your pump, some water or solvent used in cleaning may remain in the fluid section. Whether your sprayer is new or if you have already used it, this fluid must be purged and thoroughly cleaned out of the system prior to use. Follow the steps below.

1. Before priming, squirt a teaspoon of separating oil (P/N 0516444, sold separately) into the indicated area. Light household oil can be substituted if necessary.

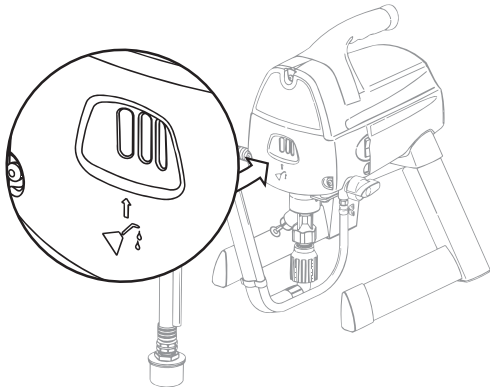

2. If you have a model XT250, fully insert the Quickflo™ valve to make sure the inlet ball is free.

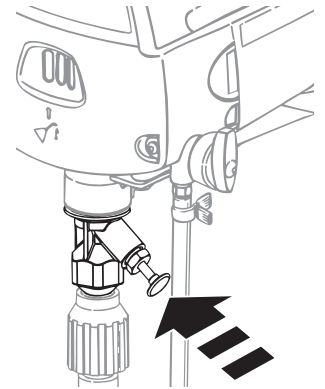

All other units have the Sureflo™ valve that will activate automatically when the pump is turned ON (I).

3. Place a full container of spraying material underneath the suction tube (a). Secure the return tube (b) into a waste container.

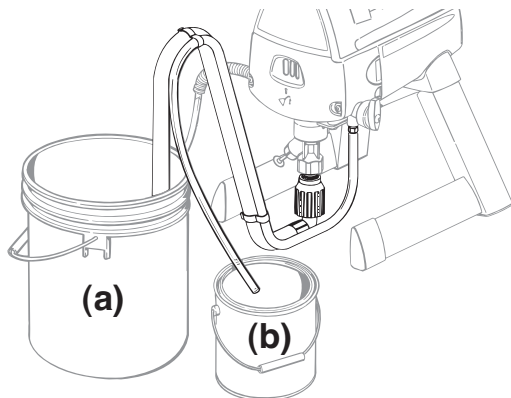

4. Slide the PressureTrac™ to maximum pressure (+). Turn the PRIME/SPRAY knob to PRIME.

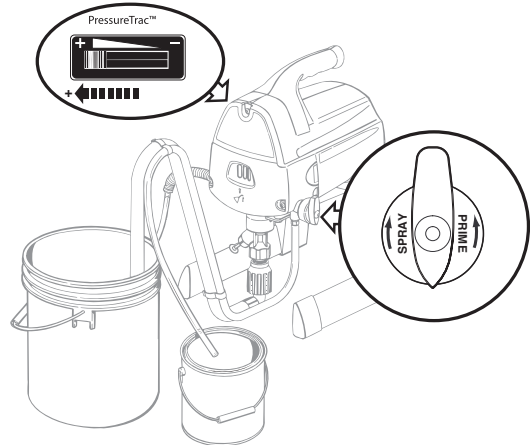

5. Plug in the sprayer and move the ON/OFF switch to the ON (I) position.

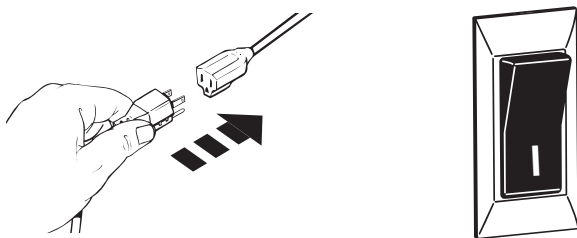

The unit will begin to draw material up the suction tube, into the pump, and out the return tube. Let the unit cycle long enough to remove test fluid from the pump, or until spray material is coming from the return tube.

6. Switch the pump OFF (O). Remove the return tube from the waste container and place it in its operating position above the container of spraying material. Use the metal clip to bind the two hoses together.

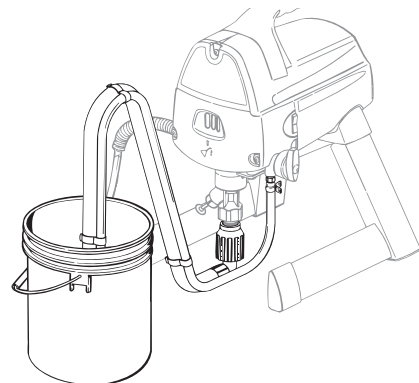



# Preparing the Spray Hose and Spray Gun



The spray tip assembly should not be attached to the spray gun when purging the spray hose. Failure to comply could result in an injection injury.

1. Unlock the spray gun and turn the PRIME/SPRAY knob to PRIME.
2. PULL the trigger and aim the spray gun at the side wall of a waste container.



If using oil-based materials, the spray gun must be grounded (see [Grounding the Spray Gun](#), page 7).

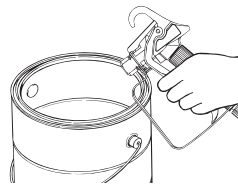
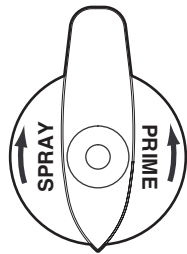

3. While pulling the trigger, switch the pump ON (I), and turn the PRIME/SPRAY knob to SPRAY. Hold the trigger until all air, water, or solvent is purged from the spray hose and material is flowing freely.

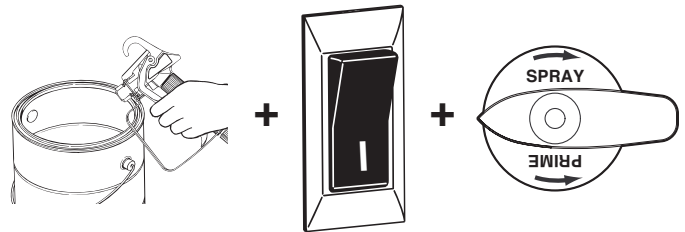

Whenever the PRIME/SPRAY knob is still on SPRAY, there will be high pressure in the hose and spray gun until the PRIME/SPRAY knob is turned to PRIME.

4. Release trigger and perform the [Pressure Relief Procedure](#), page 7).
5. Lock the spray gun trigger.
6. Make sure the saddle seat and black seal are in place inside the tip guard nut (see [Components and Description](#), page 5).
7. Insert spray tip (a) into the side of the spray guard (b). The pointed end (c) of the spray tip should be facing forward as shown.

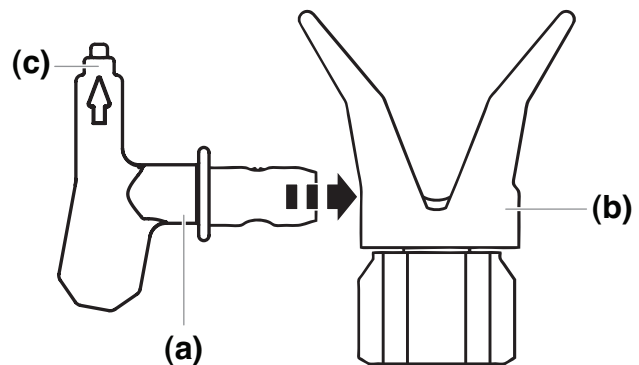

8. Thread the spray tip guard assembly onto the gun. Tighten by hand.

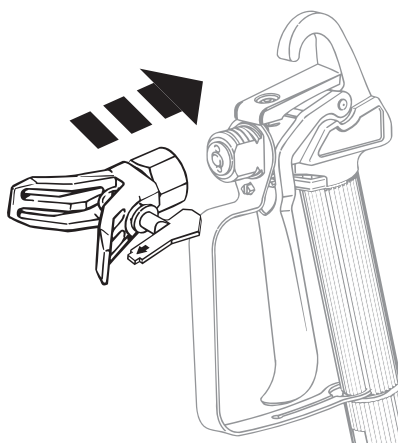

# Practice / Spraying Technique

**IMPORTANT:** Be sure that the paint hose is free of kinks and clear of objects with sharp cutting edges.

1. Switch the pump ON (I). Turn the PRIME/SPRAY knob to SPRAY. Slide the PressureTrac™ to maximum pressure (+). The spray hose should stiffen as paint begins to flow through it.

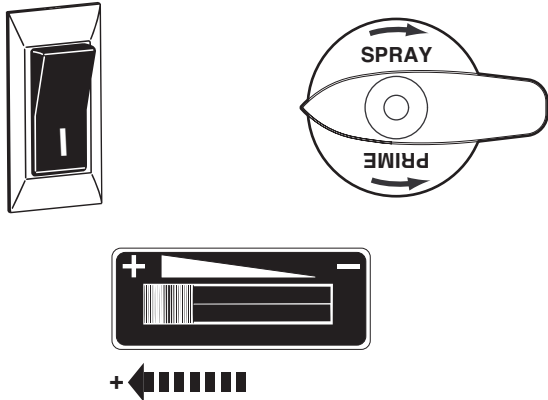

2. When motor shuts off, unlock the spray gun and spray a test area to check the spray pattern.

The motor will cycle on and off automatically as it needs pressure.

The PressureTrac™ can be adjusted left (increase) or right (decrease) to achieve the desired spray pattern.

Good spray pattern



Paint tailing pattern (pressure too low, clogged tip)



The key to a good job is an even coating over the entire surface. This is done by using even strokes. Follow the TIPS, below.

**Tip:** Keep the spray gun at right angles to the surface. This means moving your entire arm back and forth rather than just flexing your wrist.

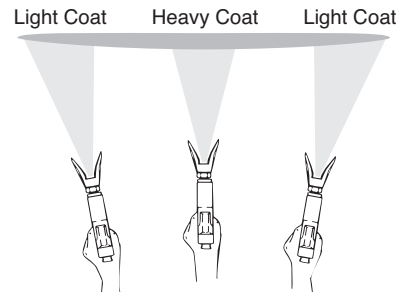

**Tip:** Keep the spray gun perpendicular to the surface, otherwise one end of the pattern will be thicker than the other.

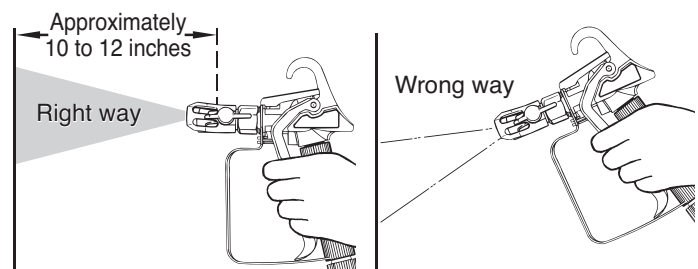

**Tip:** Trigger gun after starting the stroke. Release the trigger before ending the stroke. The spray gun should be moving when the trigger is pulled and released. Overlap each stroke by about 30%. This will ensure an even coating.

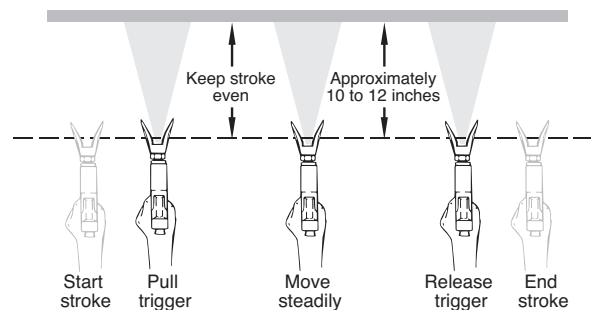

If you expect to be away from your sprayer for more than one hour, follow the **Short-Term Storage** instructions (page 18).

# Spraying Troubleshooting - Unclogging the Spray Tip

If the spray pattern becomes distorted or stops completely while the gun is triggered, follow these steps.



Do not attempt to unclog or clean the tip with your finger. High pressure fluid can cause injection injury.

**IMPORTANT:** Do not use a needle or other sharp pointed instrument to clean the tip. The hard tungsten carbide can chip.

1. Release the trigger and lock the trigger off (see page 7). Rotate the reversible tip arrow 180° so that the point of the arrow is toward the rear of the gun (CLEAN position).

Under pressure, the spray tip may be very difficult to turn. Turn the PRIME/SPRAY knob to PRIME and trigger the gun. This will relieve pressure and the tip will turn more easily.

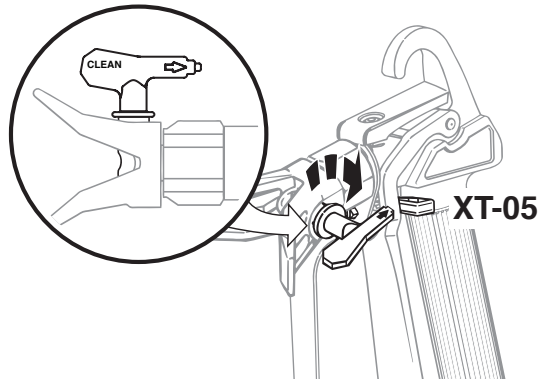

Trigger locked  
(see page 7)



2. Turn the PRIME/SPRAY knob to SPRAY.
3. Unlock the trigger and squeeze the trigger, pointing the gun at a scrap piece of wood or cardboard. This allows pressure in the spray hose to blow out the obstruction. When the nozzle is clean, material will come out in a straight, high pressure stream.

If material still will not spray from the spray tip, follow the [Cleaning the spray gun filter](#) instructions, page 12.

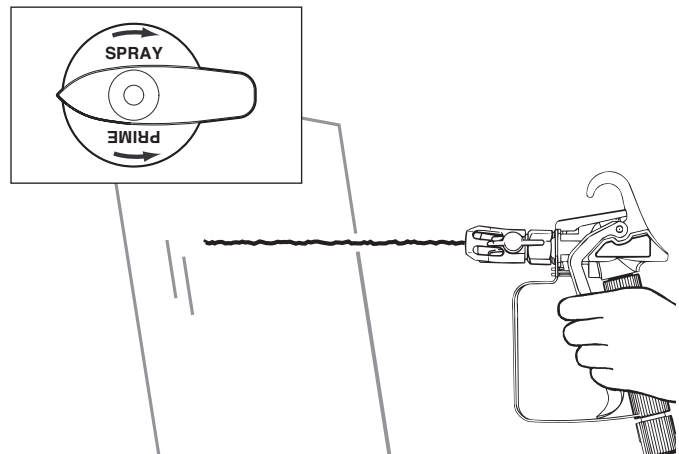

4. Release the trigger and lock the trigger off (see page 7). Reverse the tip so the arrow points forward again (SPRAY position). Unlock the gun and resume spraying.

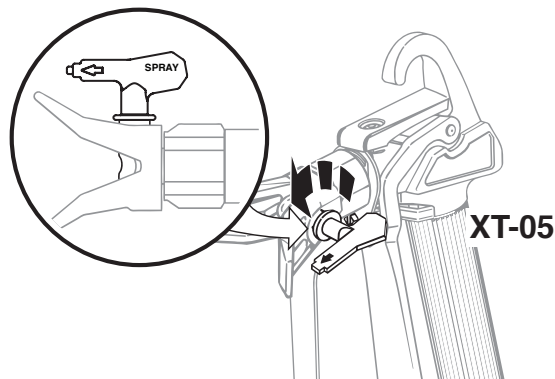

Trigger locked  
(see page 7)



# Spraying Troubleshooting - Cleaning the Spray Gun Filter

The filter must be cleaned every time you use your sprayer. When using thicker spray materials, the filter might need to be cleaned more often.

**NOTE - the LX60 threads are left-handed. Turn the filter clockwise to remove, and counterclockwise to replace.**

1. Perform **Pressure Relief Procedure**, page 7.
2. Unclip the trigger guard from the filter housing by pulling outward from the filter housing. Unscrew the filter housing.
3. Remove the filter from the spray gun housing and clean with the appropriate cleaning solution (warm, soapy water for latex paints, mineral spirits for oil-based materials). **For spray gun model LX60, the filter will need to be unscrewed from the gun housing (turn clockwise).**
4. Inspect the filter for holes (see inset, right). Replace if holes are found.

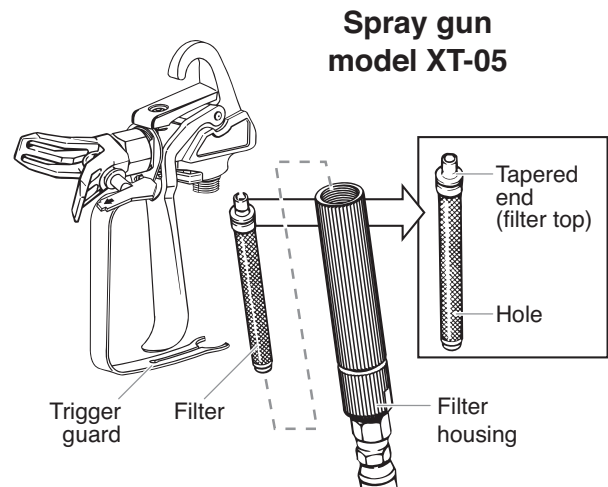

**NOTE - NEVER POKE THE FILTER WITH A SHARP INSTRUMENT!**

- 5a. **Model XT-05** - Replace the cleaned filter, tapered end first, into the gun housing. **The tapered end of the filter must be loaded properly into the gun. Improper assembly will result in a plugged tip or no flow from the gun.**
- 5b. **Model LX60** - Screw the tapered end of the filter into the gun housing (turn counterclockwise to tighten).
6. Reassemble the spray gun.

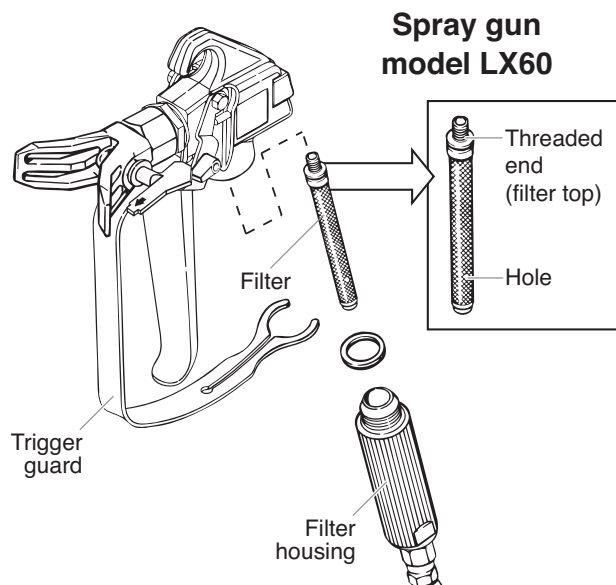

# Spraying Troubleshooting - Cleaning the Inlet Filter

The screen at the bottom of the suction tube may also need cleaning. Check it every time you change spray containers.

1. Remove the filter by unscrewing it from the suction tube. Clean the filter with the appropriate cleaning solution (warm, soapy water for latex materials, mineral spirits for oil-based materials).
2. Thread the filter back into place.

If after completing all of the steps in **Spraying Troubleshooting** you are still experiencing problems spraying, refer to the **Troubleshooting** section (page 22).

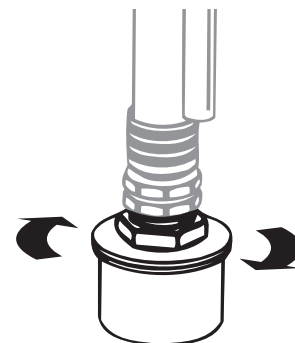

# Cleanup

## Important Cleaning Notes - Read before cleaning

- When using latex materials, clean your sprayer and components with water. When using oil-based materials, use mineral spirits. **DO NOT** use gasoline to clean your sprayer.
- Do not use mineral spirits on latex materials, or the mixture will turn into a jelly-like substance which is difficult to remove.
- No matter which cleaning solution you use, make sure to dispose of it properly when finished cleaning your sprayer.
- Thorough cleaning and lubrication of the sprayer is the most important step you can take to ensure proper operation after storage.



Follow these steps whenever cleaning with mineral spirits:

- Always flush spray gun at least one hose length away from spray pump.
- If collecting flushed solvents in one gallon metal container, place it into an empty five gallon container, then flush.
- Area must be free from vapors.
- Follow all cleanup instructions.
- **DO NOT** use gasoline to clean your sprayer.

Call 1-866-Titan XT if you have any problems or questions regarding the cleaning of your sprayer.

Follow these steps if you used latex materials and if you have a garden hose available. If you do not have a garden hose available, follow the Cleanup - Oil-Based Materials instructions.

1. Lock the gun and remove the spray tip assembly. Place the suction tube and return tube into an empty waste container.

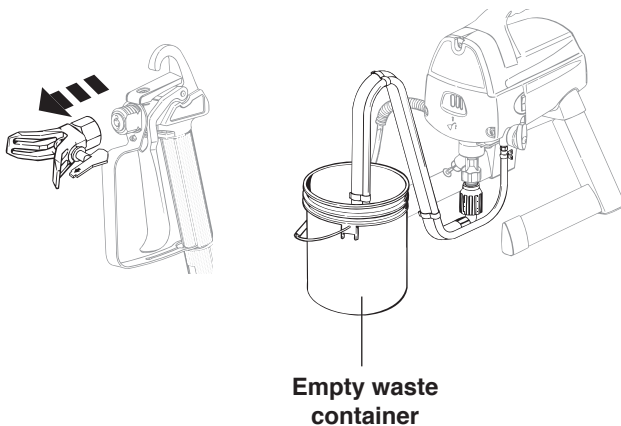

2. Using a garden hose, rinse off the suction tube, return tube and inlet filter. Empty the waste container.

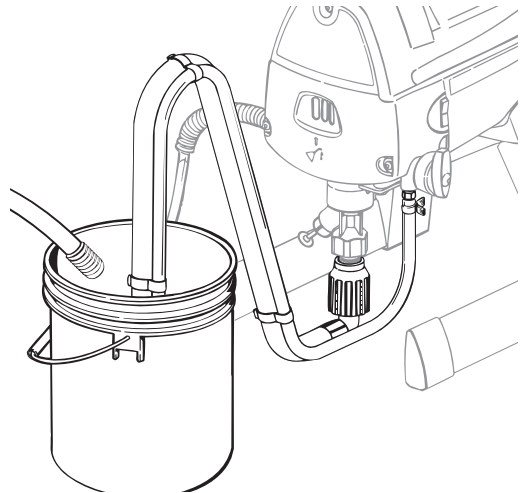

3. Remove the inlet filter from the suction tube and place into the waste container.

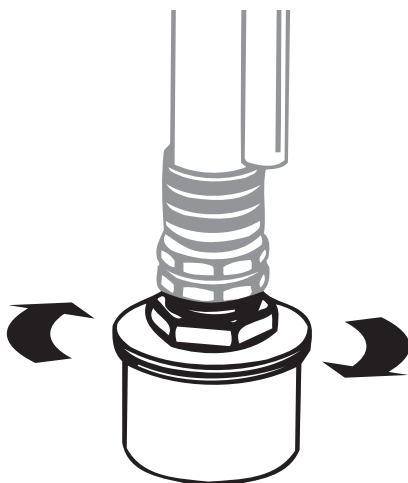

4. Verify that the seals are present inside the adapter and suction tube (a). Thread the pump cleaning adapter (b) onto a garden hose (c). Connect hose and adapter to the fitting on the end of the suction tube (d).

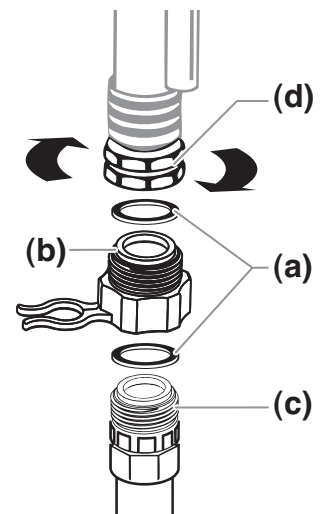

Continued on next page.

# Cleanup - Latex materials (continued)

- Unclip the return tube from the suction tube and place it into the waste container. Turn the PRIME/SPRAY knob to PRIME.

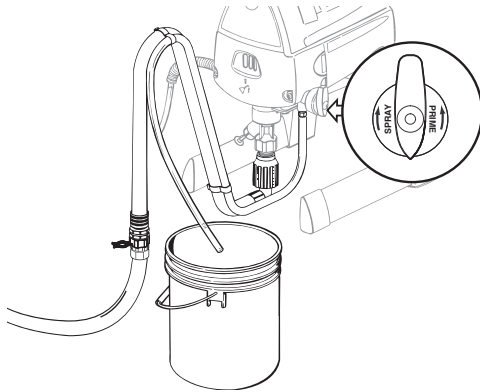

- Turn water supply on. Turn pump ON (I). Water will go into the suction tube and out through the return tube. Let pump run for a few minutes to allow the return tube to be flushed.

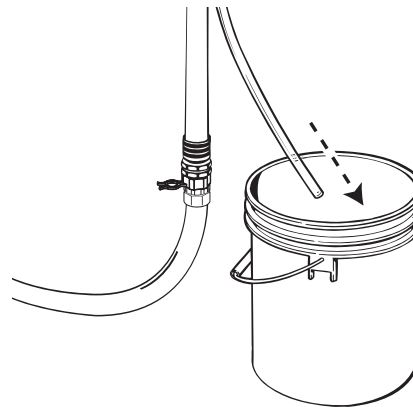

Leave pump running through steps 7 and 8.

- Place the original material container next to the waste container. Aim the spray gun into the side of the **original material container** and hold the trigger.

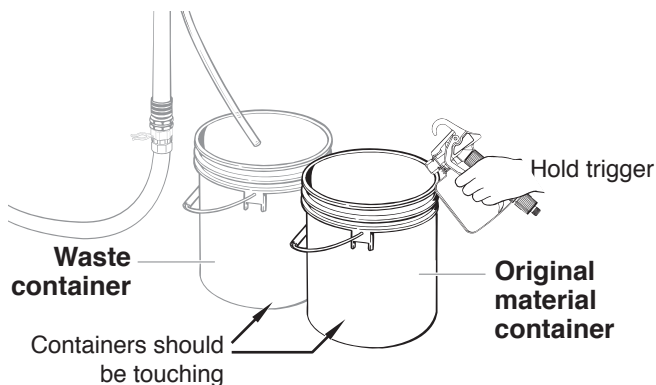

- While pulling the trigger, turn the PRIME/SPRAY knob to SPRAY to purge material from the hose back into the original container.

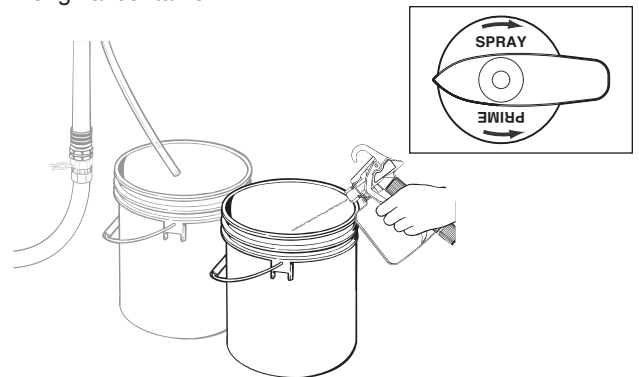

Keep holding trigger through next steps.

- When cleaning solution flows from the spray gun, keep holding the trigger and aim the spray gun into the side of the waste container.

- Trigger the gun until the fluid flowing out of the gun is clear. You may need to empty the waste container and continue flushing.

- Turn the PRIME/SPRAY knob to PRIME and trigger gun to relieve pressure.

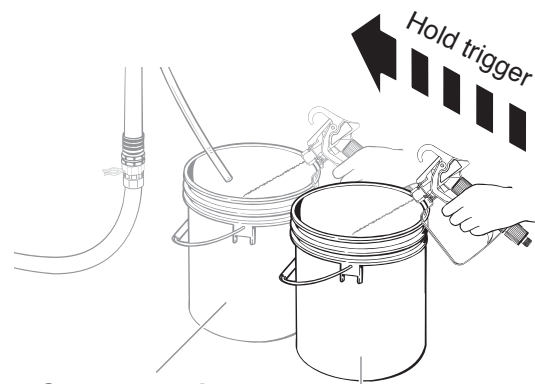

Spray water into waste container

Spray material into original container

Move on to Cleaning the Spray Gun Components.

# Cleanup - oil-based materials

1. Lock the gun and remove spray tip assembly. Submerge suction set into a bucket with appropriate cleaning solution.

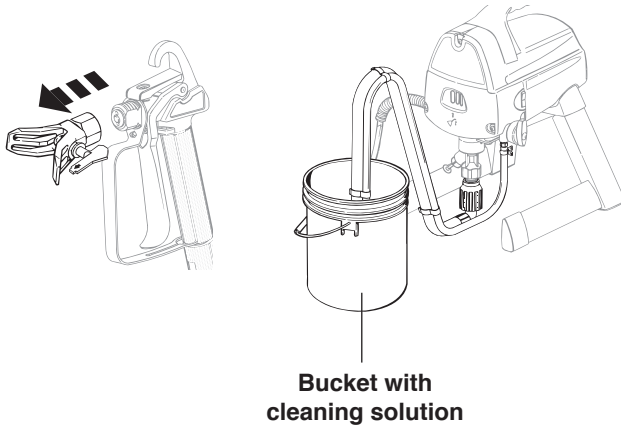

2. Place a waste container next to the original material container. Aim the spray gun into the side of the **original material container** and hold the trigger.

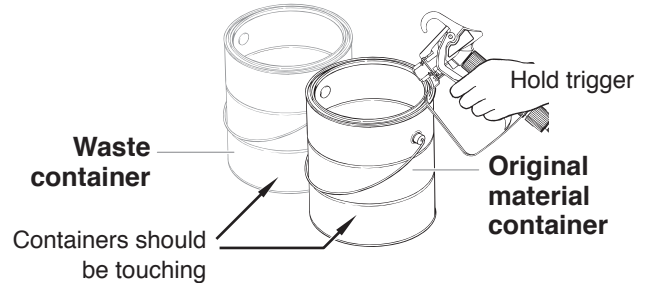

3. While pulling the gun trigger, turn the pump ON (I), and turn the PRIME/SPRAY knob to SPRAY to purge material from the hose back into the original container.

Keep holding trigger through next steps.

- Hold trigger
- Turn pump ON (I)
- Turn PRIME/SPRAY knob to SPRAY



4. When cleaning solution flows from the spray gun, keep holding the trigger and aim the spray gun into the side of the waste container (**ground gun with a metal container if flushing with flammable solvent**).
5. Trigger the gun until the fluid flowing out of the gun is clear. You may need to dispose and obtain new cleaning solution.
6. Turn the PRIME/SPRAY knob to PRIME and trigger gun once to relieve pressure.

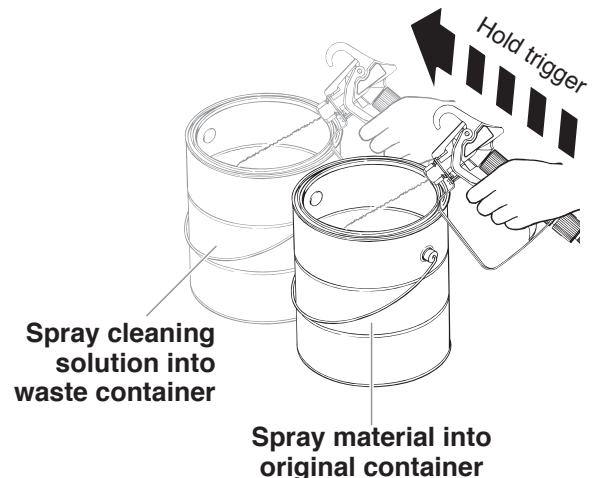

Move on to Cleaning the Suction Set.

# Cleaning the Suction Set

1. Lock the gun and turn the pump OFF (O).

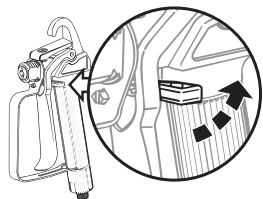

XT-05

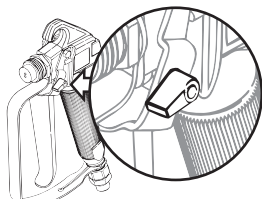

LX60

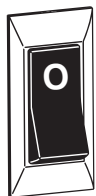

2. Remove the suction hose and return tube and clean it using the appropriate cleaning solution. You should also wipe the threads of the inlet nut (a) and remove and clean the inlet filter.

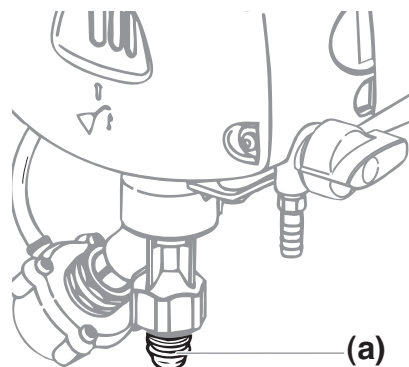

3. When suction set is clean, thread the suction tube back into the inlet valve, and replace the return tube onto the return tube fitting. Replace clip.

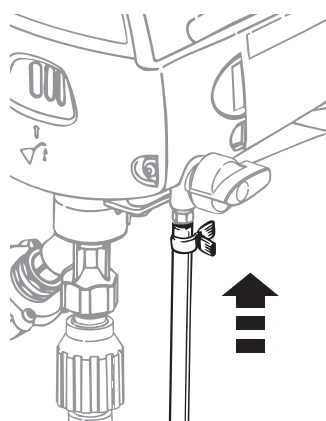
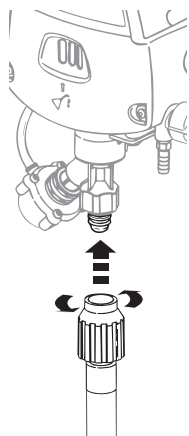

4. Submerge the suction set into a bucket of new cleaning solution.

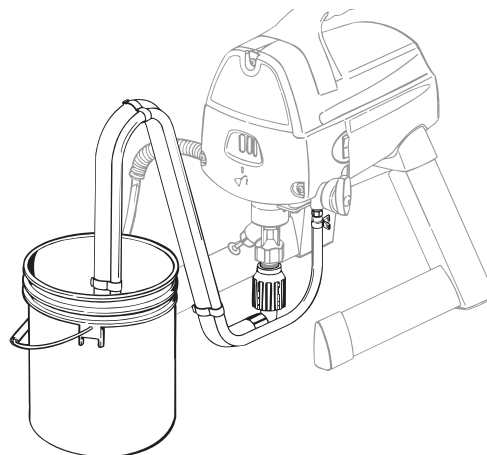

5. Turn the PRIME/SPRAY knob to PRIME. Turn the pump ON (I), and trigger the gun once into a waste container to relieve pressure.

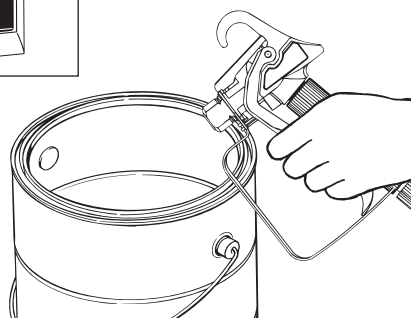
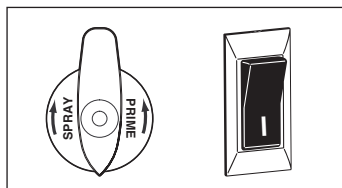

6. Let the pump circulate cleaning solution through the suction set for 2-3 minutes. Turn the pump OFF.



2 to 3 minutes

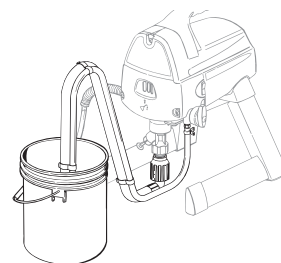

## IMPORTANT!

If you used oil-based materials, you must flush the pump again using water to prepare it for storage. Repeat #1 - #11 in Cleanup- Latex materials, instructions.

Move on to **Cleaning the Spray Gun Components.**



# Cleaning the Spray Gun Components

1. Make sure the pump is switched OFF (O). Make sure the PRIME/SPRAY knob is turned to PRIME. Unplug the sprayer.

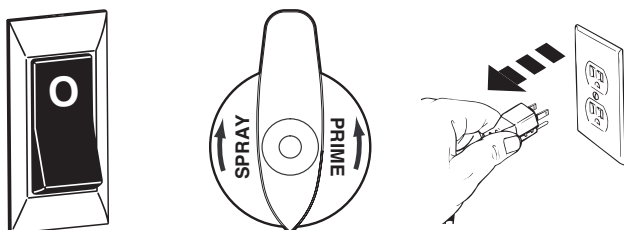

2. Remove spray gun from the paint hose using adjustable wrenches.

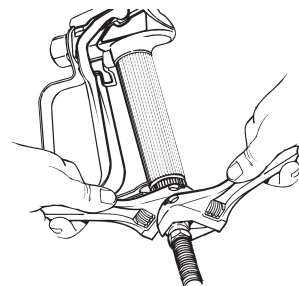

3. Remove filter from spray gun (refer to [Cleaning the Spray Gun Filter](#), page 12).

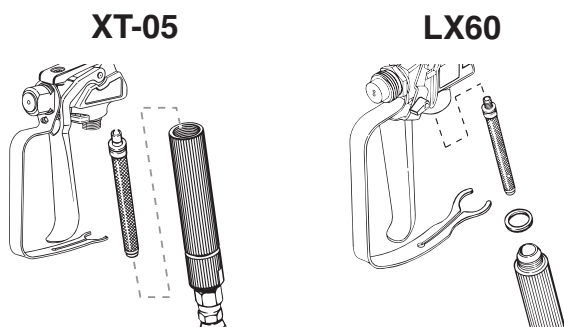

4. Remove spray tip (a) from spray guard assembly. Clean spray tip with a soft-bristled brush and the appropriate cleaning solution. Be sure to remove and clean the washer (b) and saddle seat (c) located in the rear of the spray tip assembly.

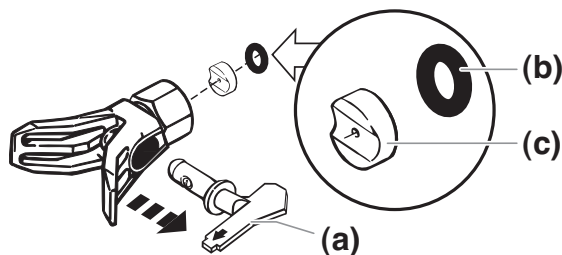

5. Install gun filter tapered-end first. Reassemble spray gun.

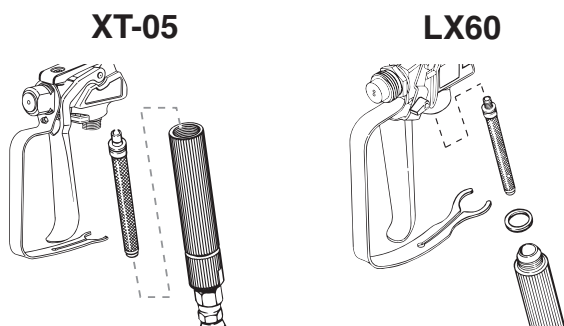

6. Install spray tip (a), saddle seat (c) and washer (b), and replace spray guard assembly.

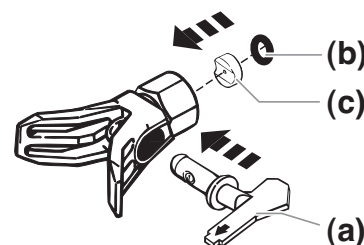

7. Thread the spray gun back onto the paint hose. Tighten with a wrench.

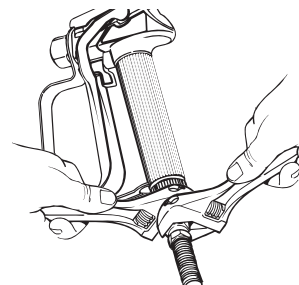

# Short-Term Storage (up to 16 hours)

Follow these steps when using latex materials only. If using materials that are oil-based, follow the Cleanup and Long-Term Storage steps.

## Shutdown

1. Lock the spray gun off.

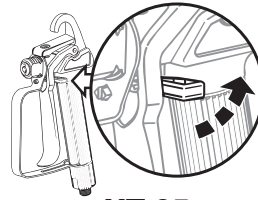

XT-05

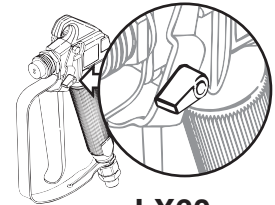

LX60

2. Turn the PRIME/SPRAY knob to PRIME. Switch the pump OFF (O). Unplug the sprayer.

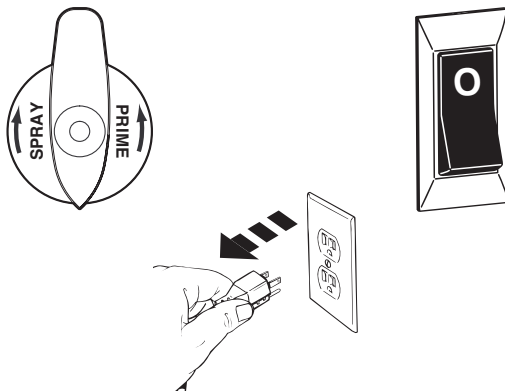

3. Pour 1/2 cup water slowly on the top of the paint to prevent the paint from drying. Wrap the spray gun assembly in a damp cloth and place it in a plastic bag. Seal the bag shut. Place the sprayer in a safe place out of the sun for short-term storage.

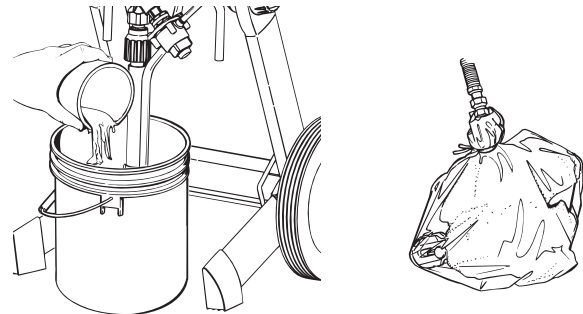

## Startup

1. Remove the gun from the plastic bag. Stir the water into the paint.

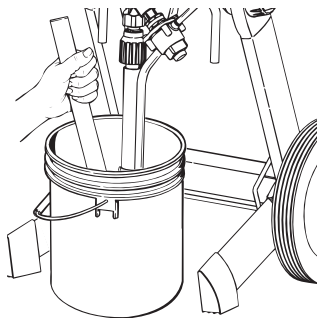

2. Turn the PRIME/SPRAY knob to PRIME. Plug sprayer in. Turn the switch to ON (I).

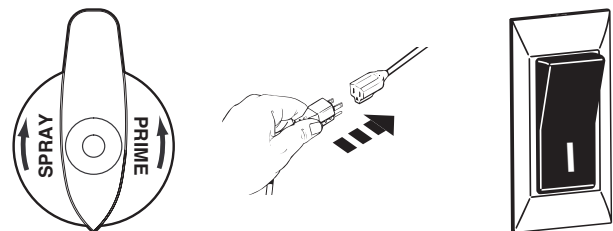

3. Turn the PRIME/SPRAY knob to SPRAY. Test the sprayer on a practice piece and begin spraying.

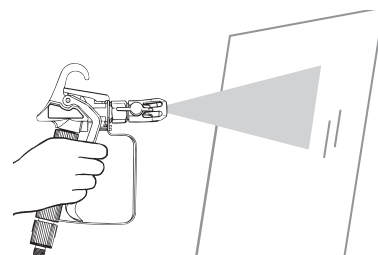

# Long-Term Storage

Follow these instructions only after all cleanup steps have been performed.

1. Fill a cup or other container with two ounces of separating oil (P/N 0516444, sold separately) and submerge the inlet valve into the oil. Light household oil can be substituted.
2. Place a rag over the spray hose port, and turn the switch ON (I). When the oil has been pumped from the cup, turn the pump OFF (O).

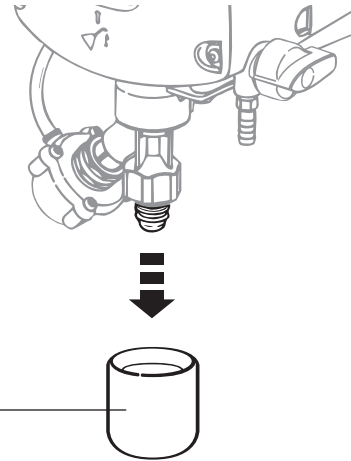

Separating oil

3. If you have a model XT250, fully insert the Quickflo™ valve.

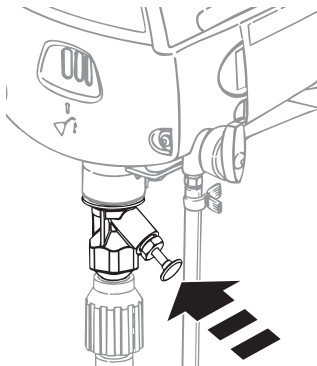

4. Wipe the entire unit, hose and gun with a damp cloth to remove accumulated paint. Replace the high pressure hose to the paint hose port.

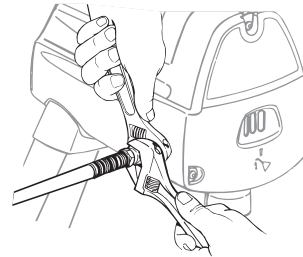

If you have a cart model (XT290 or XT330), you can collapse the cart for easier storage.

1. With one hand on the handle, twist the knob on either side of the cart toward the “DOWN” arrow.

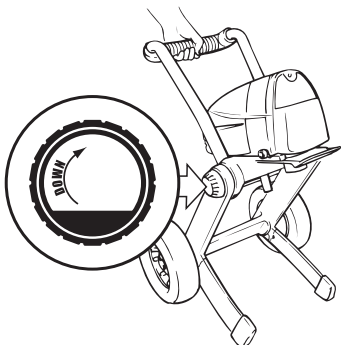

2. When the knob is fully “DOWN”, this will release the handle and it can be folded down until it is locked into place. **Be careful not to pinch the power cord with the cart.**

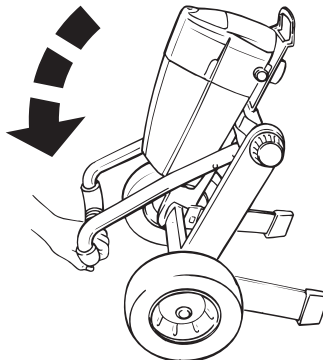

3. Lift the leg lock, and fold the legs in. Replace the leg lock to hold the legs into place (inset).

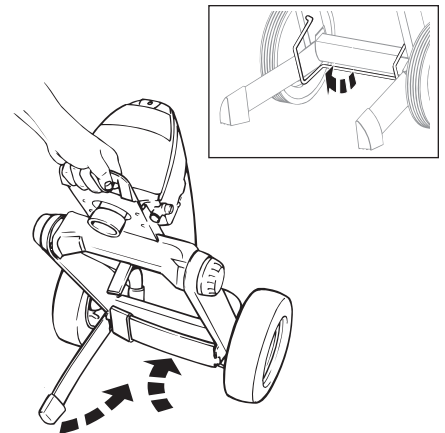

# Cleaning the Inlet Valve

Cleaning or servicing the inlet valve may be required if the unit has priming problems. Priming problems may be prevented by properly cleaning the sprayer and following the long-term storage steps.

1. Remove the suction set.

If you have a model XT290 or XT330, loosen the fitting as shown (a) and remove the Sureflo™ valve solenoid.  
If you have a model XT250, skip to step 2.

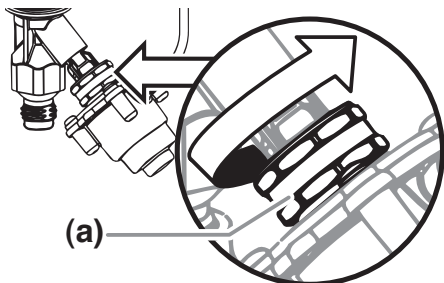

2. Unscrew the inlet valve assembly (b) from the sprayer. Visually inspect the inside and outside of the inlet valve assembly. Clean any paint residue with the appropriate cleaning solution.

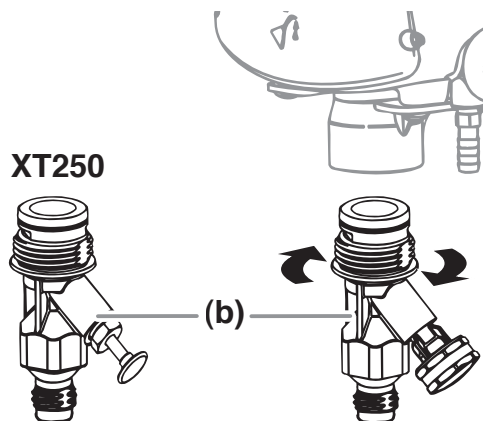

3. Replace inlet valve assembly by screwing it into the sprayer.

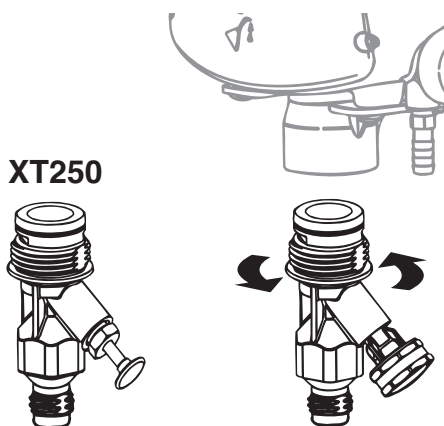

4. Replace Sureflo™ valve solenoid.

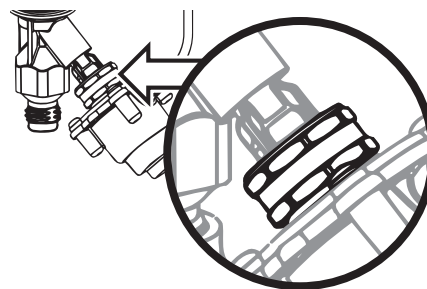

If priming problems persist, you may need to replace the inlet valve assembly. Call Technical Service to order new inlet valve assembly.

# Fluid Section Seal Replacement Instructions

Kit Part Number 0516701 (XT250, XT290)

Kit Part Number 0516700 (XT330)



**Always wear protective eye wear while servicing the pump. Be sure to follow the Pressure Relief Procedure (page 7) when shutting the unit down for any purpose, including servicing or adjusting. After performing the Pressure Relief Procedure, be sure to unplug the unit before servicing or adjusting. Area must be free of solvents and paint fumes.**

## Disassembly of the Fluid Section

1. Remove the suction set.
2. Remove the front cover and the three screws that secure it using a T20 Torx head driver.
3. Remove the yoke screw and washer that secures the dowel pin. The dowel pin connects the yoke to the piston.
4. Using a pliers, pull the dowel pin out.
- 5a. **For models XT250 and XT290**, rotate the pump shaft so the piston is in the top dead center position. This can be done by pushing on the yoke. This is required to disassemble all the parts.
- 5b. **For model XT330**, inspect the yoke assembly and piston. In order to remove all the necessary parts, the piston must not be in the bottom dead center position. If the piston is at the bottom of the stroke, install the front cover and screws, turn the pump on briefly to index the piston, unplug the unit, and repeat step 2.
6. Remove Sureflo™ valve solenoid. Unscrew and remove the inlet valve assembly (see page 20).
7. Remove the piston assembly by pushing down on the piston near the yoke.
8. Unscrew and remove the top nut using an adjustable wrench.
9. Remove the worn seals using a flat head screwdriver or punch. Remove the top seal from the top and the bottom seal from the bottom by pressing against the side of the seal and popping it out. Be sure not to scratch the housing where the seals are located.
10. Clean the area where the new seals are to be installed.

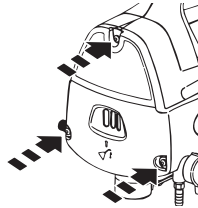

4. Install the new O-ring on the inlet valve assembly, lubricate with Separating Oil (P/N 0516444, sold separately) or light household oil, thread into the bottom (inlet) of the housing, and tighten with an adjustable wrench. This will drive the bottom seal into the correct position.
5. Align the piston with the yoke. Be careful not to damage the piston.
6. Apply a lithium grease to the holes in the yoke where the dowel is inserted.
7. Install the dowel pin to connect the yoke to the piston. The piston may have to be moved up or down to do this. The inlet valve may need to be removed again to move the piston.
8. Install the yoke screw and washer to secure the dowel pin.
9. Turn pump right side up and apply a few drops of Separating Oil (P/N 0516444, sold separately) or light household oil between the top nut and piston. This will prolong the seal life.
10. Install front cover and three (3) screws.
11. Install the inlet valve assembly. Install the suction set and Sureflo™ valve solenoid.

## Assembly of the Fluid Section

1. Lubricate the new top seal with Separating Oil (P/N 0516444, sold separately) or light household oil and by hand place the seal (cup side of seal down) into the top port of the housing.
2. Place a small amount of anti-seize on the threads of the top nut. Place the top nut into the top of the housing and tighten with an adjustable wrench. This will drive the top seal into the correct position.
3. Turn the pump upside down. Lubricate the seal on the piston/seal assembly similar to the top seal. Place the piston/seal assembly into the bottom of the housing. Insert the plastic insertion tool and thread into position to properly seat the piston/seal. Thread fully until tight. Remove the insertion tool.

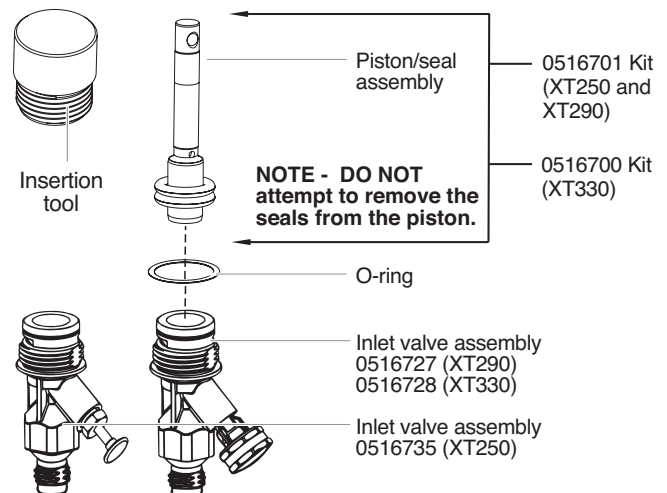
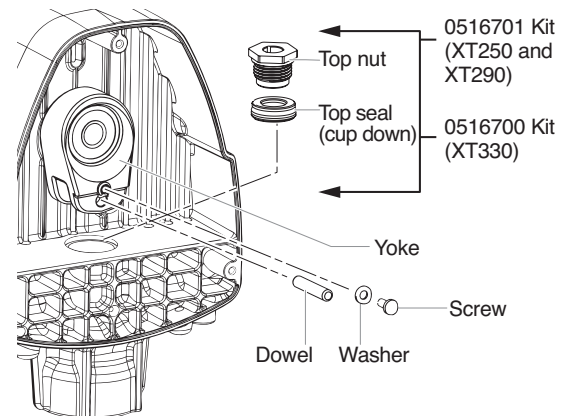
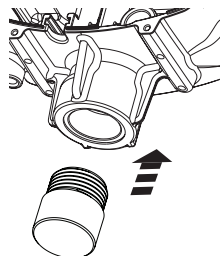

# Troubleshooting / Maintenance



Before servicing, always release system pressure by following **Pressure Relief Procedure** (page 7).

Problem	Cause	Solution
A. The sprayer does not start.	<ol style="list-style-type: none"> <li>The sprayer is not plugged in.</li> <li>The ON/OFF switch is set to OFF.</li> <li>The sprayer was turned off while still under pressure.</li> <li>No voltage is coming from the wall plug.</li> <li>The extension cord is damaged or has too low a capacity.</li> <li>A fuse is blown in the sprayer.</li> <li>There is a problem with the motor.</li> </ol>	<ol style="list-style-type: none"> <li>Plug the sprayer in.</li> <li>Turn the ON/OFF switch to ON.</li> <li>Slide the PressureTrac™ to maximum pressure (+), or relieve pressure by turning the PRIME/SPRAY valve to PRIME.</li> <li>Properly test the power supply voltage.</li> <li>Replace the extension cord.</li> <li>Take sprayer to Authorized Service Center.</li> <li>Take sprayer to Authorized Service Center.</li> </ol>
B. The sprayer starts but does not draw in paint when the PRIME/SPRAY knob is set to PRIME.	<ol style="list-style-type: none"> <li>The unit will not prime properly or has lost prime.</li> <li>The paint bucket is empty or the suction tube is not totally immersed in the paint.</li> <li>The suction set is clogged.</li> <li>The suction tube is loose at the inlet valve.</li> <li>The inlet valve is stuck.</li> <li>The inlet valve is worn or damaged.</li> <li>The PRIME/SPRAY valve is plugged.</li> </ol>	<ol style="list-style-type: none"> <li>Try to prime the unit again.</li> <li>Refill the bucket or immerse the suction tube in paint.</li> <li>Clean the suction set.</li> <li>Clean the tube connection and tighten it securely.</li> <li>Clean the inlet valve. Inlet may be stuck from old paint. Operate Quickflo™ or Sureflo™ valve to release.</li> <li>Replace the inlet valve.*</li> <li>Take sprayer to Authorized Service Center.</li> </ol>
C. The sprayer draws up paint but the pressure drops when the gun is triggered.	<ol style="list-style-type: none"> <li>The spray tip is worn.</li> <li>The suction set screen is clogged.</li> <li>The gun filter is plugged.</li> <li>The paint is too heavy or coarse.</li> <li>The inlet valve assembly is damaged or worn.</li> </ol>	<ol style="list-style-type: none"> <li>Replace the spray tip with a new tip.**</li> <li>Clean the suction set screen.</li> <li>Clean or replace the proper filter. Always keep extra filters on hand.</li> <li>Thin or strain the paint.</li> <li>Replace the inlet valve.*</li> </ol>
D. The PRIME/SPRAY valve is on SPRAY and there is flow through the return tube.	<ol style="list-style-type: none"> <li>The PRIME/SPRAY valve is dirty or worn.</li> </ol>	<ol style="list-style-type: none"> <li>Take sprayer to Authorized Service Center.</li> </ol>
E. The spray gun leaks.	<ol style="list-style-type: none"> <li>Internal parts of the gun are worn or dirty.</li> </ol>	<ol style="list-style-type: none"> <li>Take the sprayer to a Authorized Service Center.</li> </ol>
F. The tip assembly leaks.	<ol style="list-style-type: none"> <li>The tip was assembled incorrectly.</li> <li>A seal is worn.</li> </ol>	<ol style="list-style-type: none"> <li>Check the tip assembly and assemble properly.</li> <li>Replace the seal.**</li> </ol>
G. The spray gun will not spray.	<ol style="list-style-type: none"> <li>The spray tip or the gun filter is plugged.</li> <li>The spray tip is in the CLEAN position.</li> </ol>	<ol style="list-style-type: none"> <li>Clean the spray tip or gun filter.</li> <li>Put the tip in the SPRAY position.</li> </ol>
H. The paint pattern is tailing.	<ol style="list-style-type: none"> <li>The pressure is set too low.</li> <li>The gun, the tip, or the suction filter is plugged.</li> <li>The suction tube is loose at the inlet valve.</li> <li>The tip is worn.</li> <li>The paint is too thick.</li> <li>Pressure loss.</li> </ol>	<ol style="list-style-type: none"> <li>Increase the pressure.</li> <li>Clean the filters.</li> <li>Tighten the suction tube fitting.</li> <li>Replace the spray tip.</li> <li>Thin the paint.</li> <li>Refer to Causes and Solutions for problem C.</li> </ol>

\* Special repair kits with instructions are available for these procedures. Refer to the **Maintenance** section of this manual for a list of the kits and their part numbers.

\*\* Additional parts are available for this procedure. Refer to the **Accessories** (page 47) section of this manual for a list of the parts and their part numbers.

## Daily Maintenance

The only daily maintenance necessary is thorough cleaning and lubricating after usage. Follow the cleaning and lubricating procedures in this manual.

## Extended Maintenance

Some pump parts eventually wear out from use and must be replaced. The following list indicates the available repair kits for the parts replaced by each kit. However, pump performance is the only reliable indicator of when to replace wear parts. Refer to the **Troubleshooting** section for more information on when to use these kits.

Kit Part #	Description
0516701	Fluid Section Seal Kit (XT250, XT290)
0516700	Fluid Section Seal Kit (XT330)
0516735	Inlet Valve Kit (XT250)
0516727	Inlet Valve Kit (XT290)
0516728	Inlet Valve Kit (XT330)

# Parts List • Liste de pièces

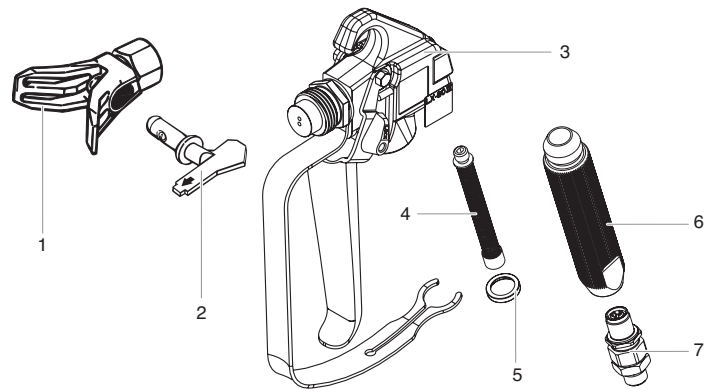
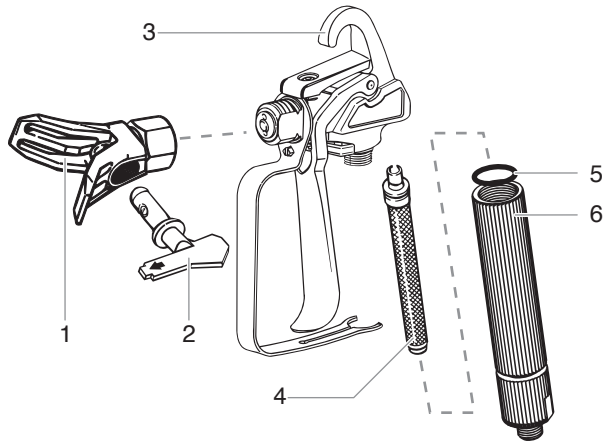

## English

### Model XT-05 spray gun (XT250 and XT290)

Item	Part #	Description	Quantity
1	0516711	Guard Assembly.....	1
2	0516707	Tip, 415 .....	1
3	0516717	Complete gun assembly.....	1
4	0516732	Filter 100 mesh (yellow)*	
5	0515332	Seal .....	1
6	0515329	Filter housing.....	1

\*2-pack replacement kit

## Français

### Modèle du pistolet XT-05 (XT250 et XT290)

Article	N° de pièce	Description	Quantité
1	0516711	Protège-embout et ses composants 1	
2	0516707	Embout, 415.....	1
3	0516717	Pistolet et ses composants.....	1
4	0516732	Filtre, jaune*	
5	0515332	Joint d'étanchéité .....	1
6	0515329	Logement de filtre.....	1

\*Emballage de 2 pour rechange

## English

### Model LX60 spray gun (XT330)

Item	Part #	Description	Quantity
1	0516711	Tip guard .....	1
2	0516704	Tip, 517 .....	1
3	0516719	Complete gun assembly.....	1
4	0516737	Filter, white*	
5	560-038	Handle seal .....	1
6	0296342	Handle .....	1
7	0347706	Swivel.....	1

\*2-pack replacement kit

## Français

### Modèle du pistolet LX60 (XT330)

Article	N° de pièce	Description	Quantité
1	0516711	Protège-embout et ses composants 1	
2	0516704	Embout, 517 .....	1
3	0516719	Pistolet et ses composants.....	1
4	0516737	Filtre blanc*	
5	560-038	Joint de poignée.....	1
6	0296342	Poignée .....	1
7	0347706	Pivot .....	1

\*Emballage de 2 pour rechange

# Parts List • Liste de pièces

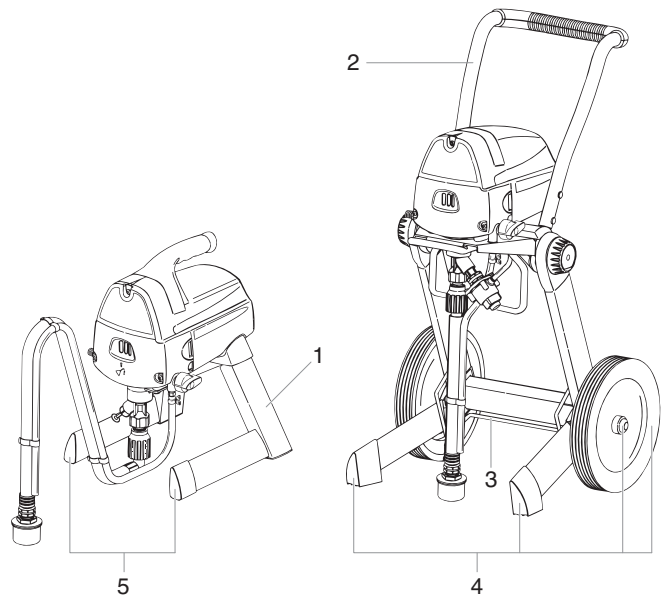
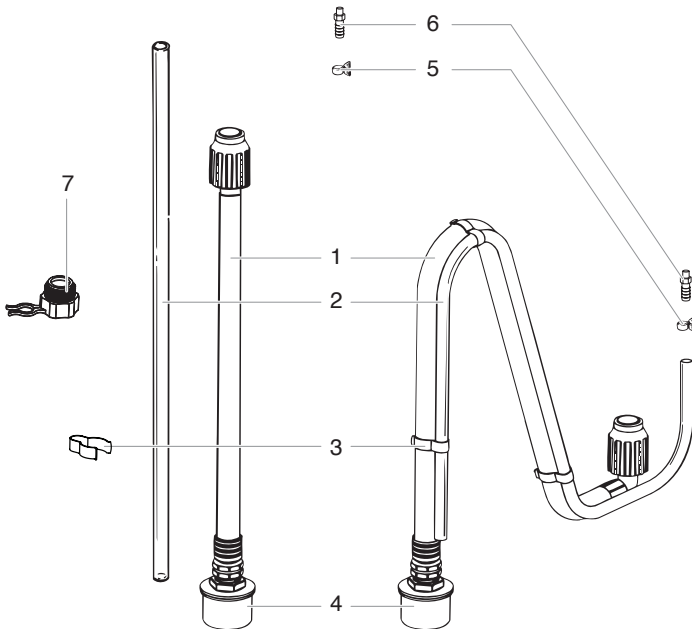

## English

### Suction Set

Item	Part #	Description	Quantity
1	0516197	Suction set (XT250).....	1
	0516196	Suction tube (all cart models).....	1
2	0512371	Return tube (XT250).....	1
	0512389	Return tube (all cart models).....	1
3	0512390	Clip .....	1
4	0516697	Filter .....	1
5	0327226	Squeeze clip.....	1
6	9885553	Return tube fitting.....	1
7	0515146	Pump cleaning adapter .....	1

## English

### Cart / Stand Assembly

Item	Part #	Description	Quantity
1	0516772	Stand assembly.....	1
2	0516225	Cart assembly (XT290) .....	1
	0516252	Cart assembly (XT330) .....	1
3	0516483	Leg lock.....	1
4	0516769	Wheel/Cap kit (XT290).....	1
	0516770	Wheel/Cap kit (XT330).....	1
5	0516773	Cap kit (XT250) .....	1

## Français

### Dispositif d'aspiration

Article	N° de pièce	Description	Quantité
1	0516197	Dispositif d'aspiration et ses composants (XT250).....	1
	0516196	Tube d'aspiration (modèles du chariot).....	1
2	0512371	Tube de retour (XT250).....	1
	0512389	Tube de retour (modèles du chariot)	1
3	0512390	Agrafe.....	1
4	0516697	Filtre .....	1
5	0327226	Agrafe de compression .....	1
6	9885553	Raccord de tube de retour.....	1
7	0515146	Adaptateur de nettoyage de pompe. 1	

## Français

### Ensemble de chariot / support

Article	N° de pièce	Description	Quantité
1	0516772	Support et ses composants.....	1
2	0516225	Chariot et ses composants (XT290). 1	
	0516252	Chariot et ses composants (XT330). 1	
3	0516483	Verrou de pied.....	1
4	0516769	Trousse de Roue/capuchon (XT290)1	
	0516770	Trousse de Roue/capuchon (XT330)1	
5	0516773	Trousse de capuchon (XT250).....	1



# Accessories • Accessoires

## English

Part #	Description
0516674	Separating oil
0516701	Piston repair kit (XT250, XT290)
0516700	Piston repair kit (XT330)
0516735	Inlet valve kit (XT250)
0516727	Inlet valve kit (XT290)
0516728	Inlet valve kit (XT330)
0516713	Hose connector kit
0516711	SC tip guard
0516709	411 Trade Spray Tip
0516708	413 Trade Spray Tip
0516707	415 Trade Spray Tip
0516706	417 Trade Spray Tip
0516705	515 Trade Spray Tip
0516704	517 Trade Spray Tip
0516726	519 Trade Spray Tip
0516749	Liquid shield
0516750	Piston lubrication
0516717	XT-05 spray gun
0516730	Hose, Wireless, 25' x 1/4"
0516729	Hose, Wireless, 50' x 1/4"
0516731	Red Gun Filter (2)
0516732	Yellow Gun Filter (2)
0516733	White Gun Filter (2)
0516734	Green Gun Filter (2)
0516752	Red Gun Filter (2, LX only)
0516742	Tip Extension, 24"

## Français

N° de pièce	Description
0516674	Huile séparatrice
0516701	Trousse de réparation de piston (XT250, XT290)
0516700	Trousse de réparation de piston (XT330)
0516735	Trousse de soupape d'entrée (XT250)
0516727	Trousse de soupape d'entrée (XT290)
0516728	Trousse de soupape d'entrée (XT330)
0516713	Raccord de flexible, 0,6 cm2
0516711	Protège-doigts, SC
0516709	Embout de pulvérisation, 411
0516708	Embout de pulvérisation, 413
0516707	Embout de pulvérisation, 415
0516706	Embout de pulvérisation, 417
0516705	Embout de pulvérisation, 515
0516704	Embout de pulvérisation, 517
0516726	Embout de pulvérisation, 519
0516749	Bouclier liquide
0516750	Lubrification de piston
0516717	Modèle du pistolet XT-05
0516730	Flexible, 7,6 m x 0,6 cm
0516729	Flexible, 15,2 m x 0,6 cm
0516731	Filtre de pistolet rouge (2)
0516732	Filtre de pistolet jaune (2)
0516733	Filtre de pistolet blanc (2)
0516734	Filtre de pistolet vert (2)
0516752	Filtre de pistolet rouge (2, LX seulement)
0516742	Rallonge d'embout, 61,0 cm

# Warranty • Garantié

## LIMITED WARRANTY - AIRLESS PAINT SPRAY EQUIPMENT

This product, manufactured by Titan Tool, is warranted to the original retail purchaser against defects in material and workmanship for:

**XT250** - one year from date of purchase.

**XT330** - two years from date of purchase.

**XT290** - two years from date of purchase.

This warranty does not cover damage resulting from improper use, accidents, user's negligence or normal wear. This warranty does not cover any defects or damages caused by service or repair performed by anyone other than a Titan Authorized Service Center. This warranty does not apply to accessories.

TITAN SHALL NOT IN ANY EVENT BE LIABLE FOR ANY INCIDENTAL OR CONSEQUENTIAL DAMAGES OF ANY KIND, WHETHER FROM BREACH OF THIS WARRANTY OR ANY OTHER REASON.

If any product is defective in material and/or workmanship during the applicable warranty period, please call Titan Technical Service at 1-866-Titan XT (1-866-848-2698). **DO NOT RETURN THE PRODUCT TO THE ORIGINAL RETAILER.** Under Titan's Free Tool Replacement Program, Titan Technical Service will either replace the defective part, or refer you to your nearest Authorized Service Center for repair.

SOME STATES DO NOT ALLOW LIMITATIONS ON HOW LONG AN IMPLIED WARRANTY LASTS OR THE EXCLUSION OF INCIDENTAL OR CONSEQUENTIAL DAMAGES, SO THE ABOVE LIMITATION AND EXCLUSION MAY NOT APPLY TO YOU.

**THIS WARRANTY GIVES YOU SPECIFIC LEGAL RIGHTS, AND YOU MAY ALSO HAVE OTHER RIGHTS WHICH VARY FROM STATE TO STATE.**

## GARANTIE LIMITÉE - MATÉRIEL DE PULVÉRISATION DE PEINTURE SANS AIR

Ce produit, fabriqué par Titan Tool, est garanti, au bénéfice de l'acheteur au détail d'origine, contre tout vice de matières et toute malfaçon pour:

**XT250** - un an à compter de la date d'achat.

**XT330** - deux années à compter de la date d'achat.

**XT290** - deux années à compter de la date d'achat.

La présente garantie ne s'applique pas aux dégâts entraînés par une utilisation incorrecte, par la négligence de l'utilisateur ou par l'usure normale. La présente garantie ne s'applique pas non plus aux défauts ou dommages résultant de l'entretien ou de la réparation que fait une personne quelconque qui ne soit pas membre d'un centre d'entretien autorisé pour les produits Titan. La présente garantie ne s'applique pas aux accessoires.

TITAN NE POURRA EN AUCUN CAS ÊTRE TENUE RESPONSABLE DE DOMMAGES-INTÉRÊTS INDIRECTS OU CONSÉCUTIFS, QUE CE SOIT POUR UNE RUPTURE DE CETTE GARANTIE OU TOUTE AUTRE RAISON.

En cas de défaut de matériau ou de fabrication du produit durant la période de garantie applicable, appelez le Service technique Titan au 1 866 Titan XT (1 866 848-2698). **NE RENVOYEZ PAS LE PRODUIT AU DÉTAILLANT ORIGINAL.** Dans le cadre du programme de remplacement gratuit d'outils Titan, le Service technique Titan remplacera la pièce défectueuse ou vous indiquera le centre de service agréé le plus proche.

CERTAINES PROVINCES INTERDISENT LES RESTRICTIONS SUR LA DURÉE D'UNE GARANTIE IMPLICITE OU L'EXCLUSION DES DOMMAGES ACCESSOIRES OU INDIRECTS. IL SE PEUT DONC QUE LA RESTRICTION ET L'EXCLUSION ÉNONCÉES CI-DESSUS NE S'APPLIQUENT PAS À VOUS.

**LE PRÉSENTE GARANTIE VOUS ACCORDE DES DROITS JURIDIQUES SPÉCIFIQUES, ET VOUS AVEZ PEUT-ÊTRE D'AUTRES DROITS, QUI PEUVENT VARIER D'UNE PROVINCE À L'AUTRE.**

## Titan XT

1770 Fernbrook Lane  
Plymouth, MN 55447

# 1-866-Titan XT

U.S. Patent Nos.	6,981,852	6,933,634	7,018,181
	7,071,429	D550,327	D537,839
	D553,325	D550,329	D550,328

Other patents pending