



**Owner's Manual**  
For professional use only

Do not use this equipment  
before reading this manual!

# SPEEFLO PowrLiner 4900xLT



**Model Number**

**1 Gun**  
**2 Gun**

**759-491**  
**759-493**

**NOTE:** This manual contains important warnings and instructions. Please read and retain for reference.



## Important Safety Information • Read all safety information before operating the equipment. SAVE THESE INSTRUCTIONS.



This symbol indicates a hazardous situation, which, if not not avoided could result in death or serious injury.



To reduce the risks of fire or explosion, electrical shock, and the injury to persons, read and understand all instructions included in this manual. Be familiar with the controls and the proper usage of the equipment.



**WARNING – To reduce the risk of fire or explosion:**



1. Do not spray flammable or combustible materials near an open flame, pilot lights or sources of ignition such as hot objects, cigarettes, motors, electrical equipment and electrical appliances. Avoid creating sparks from connecting and disconnecting power cords.
2. For units intended for use with only water-based materials – Do not spray or clean with flammable liquids. For use with water-based liquids only.
3. For units intended for use with only water-based or mineral spirit-type materials with a minimum flash point of 21°C (69.8°F) – Do not spray or clean with liquids having a flash point of less than 21°C (69.8°F). Flash point is the temperature at which a fluid can produce enough vapor to ignite.
4. Paint or solvent flowing through the equipment is able to result in static electricity. Static electricity creates a risk of fire or explosion in the presence of paint or solvent fumes. All parts of the spray system, including the pump, hose assembly, spray gun and objects in and around the spray area shall be properly grounded to protect against static discharge and sparks. Use only conductive or grounded high-pressure airless paint sprayer hoses specified by the manufacturer.
5. Verify that all containers and collection systems are grounded to prevent static discharge.
6. Connect to a grounded outlet and use grounded extension cords (electric models only). Do not use a 3 to 2 adapter.
7. Do not use a paint or solvent containing halogenated hydrocarbons. Such as chlorine, bleach mildewcide, methylene chloride and trichloroethane. They are not compatible with aluminum. Contact the coating supplier about compatibility of material with aluminum.
8. Keep spray area well ventilated. Keep a good supply of fresh air moving through the area to keep the air within the spray area free from accumulation of flammable vapors. Keep pump assembly in well ventilated area. Do not spray pump assembly.
9. Do not smoke in the spray area.
10. Do not operate light switches, engines, or similar spark producing products in the spray area.
11. Keep area clean and free of paint or solvent containers, rags, and other flammable materials.
12. Know the contents of the paint and solvents being sprayed. Read all Material Safety Data Sheets (MSDS) and container labels provided with the paints and solvents. Follow the paint and solvent manufacture's safety instructions.
13. Place pump at least 25 feet (7.62 meters) from the spray object in a well ventilated area (add more hose if necessary). Flammable vapors are often heavier than air. Floor area must be extremely well ventilated. The pump contains arcing parts that emit sparks and can ignite vapors.

14. Plastic can cause static sparks. Never hang plastic to enclose spray area. Do not use plastic drop cloths when spraying flammable material.
15. Fire extinguisher equipment shall be present and working.



**WARNING – To reduce the risk of skin injection:**



### HAZARD:

**Injection injury – A high pressure fluid stream produced by this equipment can pierce the skin and underlying tissues, leading to a serious injury and possible amputation. See a physician immediately. DO NOT TREAT AN INJECTION AS A SIMPLE CUT.**

1. Do not aim the gun at, or spray any person or animal.
2. Keep hands and other body parts away from the discharge. For example, do not try to stop leaks with any part of the body.
3. Always use the nozzle tip guard. Do not spray without the nozzle tip guard in place.
4. Only use a nozzle tip specified by the manufacturer.
5. Use caution when cleaning and changing nozzle tips. In the case where the nozzle tip clogs while spraying, ALWAYS lock gun trigger, shut pump off, and release all pressure before servicing, cleaning tip or guard, or changing tip. Pressure will not be released by turning off the motor. The PRIME/SPRAY valve or pressure bleed valve must be turned to their appropriate positions to relieve system pressure. Refer to PRESSURE RELIEF PROCEDURE described in the pump manual.
6. Do not leave the unit energized or under pressure while unattended. When the unit is not in use, turn off the unit and relieve the pressure in accordance with the manufacturer's instructions.
7. High-pressure spray is able to inject toxins into the body and cause serious bodily injury. In the event that injection occurs, seek medical attention immediately.
8. Check hoses and parts for signs of damage, a leak can inject material into the skin. Inspect hose before each use. Replace any damaged hoses or parts.
9. This system is capable of producing 3300 PSI / 22.8 MPa. Only use replacement parts or accessories that are specified by the manufacturer and that are rated a minimum of 3300 PSI. This includes spray tips, nozzle guards, guns, extensions, fittings, and hose.
10. Always engage the trigger lock when not spraying. Verify the trigger lock is functioning properly.
11. Verify that all connections are secure before operating the unit.
12. Know how to stop the unit and bleed pressure quickly. Be thoroughly familiar with the controls. Pressure will not be released by turning off the motor. The PRIME/SPRAY valve or pressure bleed valve must be turned to their appropriate positions to relieve system pressure. Refer to PRESSURE RELIEF PROCEDURE described in the pump manual.
13. Always remove the spray tip before flushing or cleaning the system.



## Important Safety Information • Read all safety information before operating the equipment. SAVE THESE INSTRUCTIONS.



### WARNING – To reduce the risk of injury:

1. Always wear appropriate gloves, eye protection, clothing and a respirator or mask when painting. Hazardous vapors – Paints, solvents, insecticides, and other materials can be harmful if inhaled or come in contact with body. Vapors can cause severe nausea, fainting or poisoning.
2. Do not operate or spray near children. Keep children away from equipment at all times.
3. Do not overreach or stand on an unstable support. Keep effective footing and balance at all times.
4. Stay alert and watch what you are doing.
5. Do not operate the unit when fatigued or under the influence of drugs or alcohol.
6. Do not kink or over-bend the hose. Airless hose can develop leaks from wear, kinking and abuse. A leak can inject material into the skin.
7. Do not expose the hose to temperatures or pressures in excess of those specified by manufacturer.
8. Do not use the hose as a strength member to pull or lift the equipment.
9. Use lowest possible pressure to flush equipment.
10. Follow all appropriate local, state and national codes governing ventilation, fire prevention and operation.
11. The United States Government Safety Standards have been adopted under the Occupational Safety and Health Act (OSHA). These standards, particularly part 1910 of the General Standards and part 1926 of the Construction Standards should be consulted.
12. Before each use, check all hoses for cuts, leaks, abrasion or bulging of cover. Check for damage or movement of couplings. Immediately replace hose if any of those conditions exist. Never repair a paint hose. Replace with a conductive high-pressure hose.
13. Do not spray outdoors on windy days.
14. Always unplug cord from outlet before working on equipment (electric models only).

### Grounding Instructions

Electric models must be grounded. In the event of an electrical short circuit, grounding reduces the risk of electric shock by providing an escape wire for the electric current. This product is equipped with a cord having a grounding wire with an appropriate grounding plug. The plug must be plugged into an outlet that is properly installed and grounded in accordance with all local codes and ordinances.

**WARNING** — Improper installation of the grounding plug can result in a risk of electric shock. If repair or replacement of the cord or plug is necessary, do not connect the green grounding wire to either flat blade terminal. The wire with insulation having a green outer surface with or without yellow stripes is the grounding wire and must be connected to the grounding pin.

Check with a qualified electrician or serviceman if the grounding instructions are not completely understood, or if you are in doubt as to whether the product is properly grounded. Do not modify the plug provided. If the plug will not fit the outlet, have the proper outlet installed by a qualified electrician.

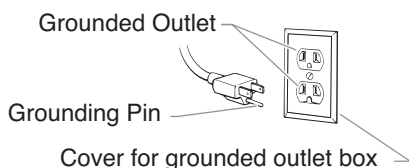

**IMPORTANT:** Use only a 3-wire extension cord that has a 3-blade grounding plug and a 3-slot receptacle that will accept the plug on the product. Make sure your extension cord is in good condition. When using an extension cord, be sure to use one heavy enough to carry the current your product will draw. An undersized cord will cause a drop in line voltage resulting in loss of power and overheating. A 12 gauge cord is recommended. If an extension cord is to be used outdoors, it must be marked with the suffix W-A after the cord type designation. For example, a designation of SJTW-A would indicate that the cord would be appropriate for outdoor use.

### Gasoline Engine Safety



**The engine exhaust from this unit contains chemicals known to the State of California to cause cancer, birth defects, or other reproductive harm.**

1. Gas engines are designed to give safe and dependable service if operated according to instructions. Read and understand the engine Owner's Manual before operating the engine. Failure to do so could result in personal injury or equipment damage.
2. To prevent fire hazards and to provide adequate ventilation, keep the engine at least 1 meter (3 feet) away from buildings and other equipment during operation. Do not place flammable objects close to the engine.
3. Children and pets must be kept away from the area of operation due to a possibility of burns from hot engine components or injury from any equipment the engine may be used to operate.
4. Know how to stop the engine quickly, and understand the operation of all controls. Never permit anyone to operate the engine without proper instructions.
5. Gasoline is extremely flammable and is explosive under certain conditions.
6. Refuel in a well-ventilated area with the engine stopped. Do not smoke or allow flames or sparks in the refueling area or where gasoline is stored.
7. Do not overfill the fuel tank. After refueling, make sure the tank cap is closed properly and securely.
8. Be careful not to spill fuel when refueling. Fuel vapor or spilled fuel may ignite. If any fuel is spilled, make sure the area is dry before starting the engine.
9. Never run the engine in an enclosed or confined area. Exhaust contains poisonous carbon monoxide gas; exposure may cause loss of consciousness and may lead to death.
10. The muffler becomes very hot during operation and remains hot for a while after stopping the engine. Be careful not to touch the muffler while it is hot. To avoid severe burns or fire hazards, let the engine cool before transporting it or storing it indoors.
11. Never ship/transport unit with gasoline in the tank.



**DO NOT use this equipment to spray water or acid.**

**IMPORTANT:** Do not lift by cart handle when loading or unloading.

## Table of Contents

<b>Safety Precautions</b> .....	<b>2</b>
Grounding Instructions .....	3
Gasoline Engine Safety .....	3
Français .....	16
Español .....	18
<b>Specifications</b> .....	<b>4</b>
<b>Introduction</b> .....	<b>5</b>
<b>Operation</b> .....	<b>5</b>
Fueling .....	5
Setup .....	6
Preparing to Paint .....	7
Painting .....	8
Operating the Front Caster .....	9
Pressure Relief Procedure .....	9
<b>Cleanup</b> .....	<b>9</b>
Cleaning a Clogged Tip .....	10
<b>Maintenance</b> .....	<b>10</b>
Daily Maintenance .....	10
Maintaining the Filter Assembly .....	10
Maintaining the Hydraulic System .....	11
Maintaining the Fluid Section .....	11
Basic Engine Maintenance (gas engine) .....	11
Replacing the Motor Brushes (electric motor) .....	12
Adjusting the Tracking on the Front Caster .....	12
<b>Troubleshooting</b> .....	<b>13</b>
Airless Gun .....	13
Fluid Section .....	13
Hydraulic Motor .....	14
Spray Patterns .....	15
<b>Parts Lists and Service Instructions</b> .....	<b>20</b>
Main Assembly .....	20
Hydraulic System Assembly .....	21
Gas Convertokit .....	22
DC— Electric Convertokit .....	22
Siphon Hose Assembly .....	23
Bleed Hose Assembly with Valve .....	23
Bleed Valve Assembly .....	23
Wheel Assembly .....	23
Cart Assembly .....	24
Hydraulic Motor .....	26
Fluid Section .....	28
Filter Assembly .....	30
Belt Guard Assembly .....	30
Trigger Assembly .....	30
SAE O-Ring Fitting Installation .....	31
<b>Accessories and Service Kits</b> .....	<b>31</b>
Second Gun Assembly .....	32
SC-6 Striping Tip Chart .....	34
<b>Electrical Schematic</b> .....	<b>33</b>
<b>Spray Gun Positions</b> .....	<b>35</b>
<b>Warranty</b> .....	<b>36</b>

## Specifications

### Gas Sprayer

Gallons per minute (GPM) .....	1.25 (4.73 LPM)
Cycle rate per gallon .....	87 (23 cycles/liter)
Maximum tip sizes .....	1 gun = .036" (.91 mm) 2 guns = .028" (.71 mm)
Maximum pressure .....	3300 psi (22.8 MPa)
Power .....	Honda 3.5 HP, 4-stroke, single cylinder, overhead valve engine w/oil alert
Fuel capacity .....	0.66 US gallons (approx. 3 hours run time)
Halogenated solvent compatible ...	Yes
Weight .....	235 lbs. (107 kg.)
Inlet paint filter .....	10 mesh "rock catcher"
Outlet paint filter .....	50 mesh, 18 in. <sup>2</sup>
Pump inlet .....	3/4" NPT(F)
Pump outlet .....	1/2" NPT(F) to paint filter
Paint filter hose connections .....	1/4" NPS(M) 3/8" NPT(F) (plugged)
Maximum spraying speed (feet/minute, 4" line width) .....	520 lineal feet (158m)
Maximum spraying speed (miles/hour, 4" line width) .....	6 mph (9.7 kph)
Line width range .....	2"–24" (5–60 cm)
Dimensions .....	59" L (150 cm) x 27" W (69 cm) x 40" H (102 cm)

### Fluid section wetted parts:

Electroless nickel plated ductile iron, electroless nickel plated carbon steel, stainless steel, tungsten carbide, UVØØ, thiokol impregnated leather, ultra high molecular weight polyethylene.

## Introduction

Congratulations on having selected the finest airless sprayer available in the world. Titan piston pumps are tireless workhorses — so tough they are virtually indestructible, even under the most severe service. Titan designs and builds equipment with superior quality and reliability. Equipment that will last for years with minimal maintenance and downtime. This equipment will make you money year after year. We thank you for your purchase and welcome you to our large and growing family of Titan users.

The unique ability of this PowrLiner to operate with either gas or electric power provides you with the flexibility to work indoors or outside where no electricity is available.

Hydraulic drive makes possible the longest stroke and slowest cycling pumps in the industry, which translates into low maintenance and longer life. Electric sprayers operate quietly with no motor starting and stopping.



This PowrLiner is equipped with Titan's exclusive fluid pump. This technology will give you significantly longer rod, cylinder, and packing life than any other sprayer built in the world. The double ball piston pump employs a dependable and durable time-tested design. All pumps use thick, stainless steel rod and cylinder parts. Highly polished parts reduce friction, extend packing life, and avoid damage from corrosion and abrasion. More than 100,000 of these pumps are in operation around the world.

This PowrLiner offers other cost saving features:

- Freeze-proof pressure control
- Choice of power — gas, electric, or both
- Tungsten carbide valve seats
- Self-adjusting packings
- Exclusive hand-tight swivel foot valve
- Large capacity inline paint filter
- Waterborne compatible
- "Floating Ball" pressure bleed valve
- 5 gallon siphon hose and bleed line assemblies are standard

You have made an excellent choice. We know you will be pleased with your new PowrLiner. Thanks again for selecting Titan. We appreciate your business.

## Operation

### Fueling (gas engine)



**Gasoline is extremely flammable and is explosive under certain conditions.**

- ALWAYS turn the engine off before refueling.
- Refuel in a well-ventilated area.
- Do not smoke or allow flames or sparks in the refueling area or where gasoline is stored.
- Do not overfill the fuel tank. After refueling, make sure the tank cap is closed properly and securely.
- Be careful not to spill fuel when refueling. Spilled fuel or fuel vapor may ignite. If any fuel is spilled, make sure the area is dry before starting the engine.
- Avoid repeated or prolonged contact with skin or breathing of vapor.
- Keep out of the reach of children.

### Fuel Specifications

- Use automotive gasoline that has a pump octane number of 86 or higher, or that has a research octane number of 91 or higher. Use of a lower octane gasoline can cause persistent "pinging" or heavy "spark knock" (a metallic rapping noise) which, if severe, can lead to engine damage.

**NOTE:** If "spark knock" or "pinging" occurs at a steady engine speed under normal load, change brands of gasoline. If spark knock or pinging persists, consult an authorized dealer of the engine manufacturer. Failure to do so is considered misuse, and damage caused by misuse is not covered by the engine manufacturer's limited warranty.

Occasionally you may experience light spark knock while operating under heavy loads. This is no cause for concern, it simply means your engine is operating efficiently.

- Unleaded fuel produces fewer engine and spark plug deposits and extends the life of the exhaust system components.
- Never use stale or contaminated gasoline or an oil/gasoline mixture. Avoid getting dirt, dust, or water in the fuel tank.

### Gasolines Containing Alcohol

If you decide to use a gasoline containing alcohol (gasohol), be sure its octane rating is at least as high as that recommended by the engine manufacturer. There are two types of "gasohol": one containing ethanol, and the other containing methanol. Do not use gasohol that contains more than 10% ethanol. Do not use gasoline containing methanol (methyl or wood alcohol) that does not also contain co-solvents and corrosion inhibitors for methanol. Never use gasoline containing more than 5% methanol, even if it has co-solvents and corrosion inhibitors.

**NOTE:** Fuel system damage or engine performance problems resulting from the use of fuels that contain alcohol is not covered under the warranty. The engine manufacturer cannot endorse the use of fuels containing methanol since evidence of their suitability is incomplete at this time.

Before buying gasoline from an unfamiliar station, try to find out if the gasoline contains alcohol. If it does, confirm the type and percentage of alcohol used. If you notice any undesirable operating characteristics while using a gasoline that contains alcohol, or one that you think contains alcohol, switch to a gasoline that you know does not contain alcohol.

## Setup



Read, understand, and follow all warnings before starting or operating this sprayer.

1. Make sure the siphon hose is connected to the fluid section and the bleed hose is connected to the bleed valve. They each have factory installed UV $\text{\AA}$  tape on the male end of the hoses and should be wrench tight.

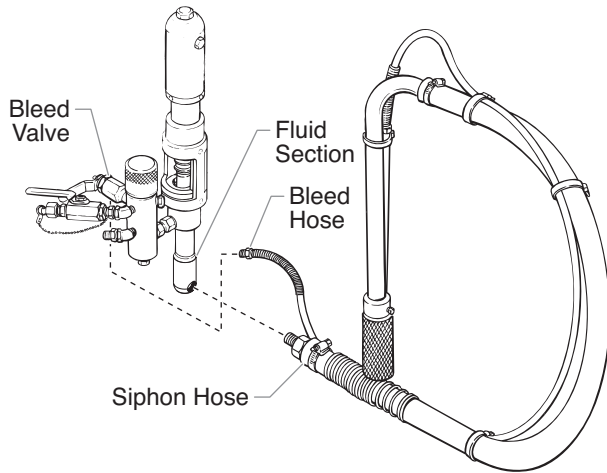

2. Install the gun support bar.

**NOTE:** The spray gun, hose, and cables are mounted to the gun support bar at the factory.

- a. Loosen the support bar clamps on each side of the cart.
- b. Slide the gun support bar through the cart.
- c. Tighten the support bar clamps to secure the gun support bar in position.

**NOTE:** The gun support bar and the spray gun(s) can be mounted on either side of the sprayer. Refer to the "Spray Gun Positions" illustration near the back of this manual.



Always follow the Pressure Relief Procedure when shutting the sprayer down for any purpose, including servicing or adjusting any part of the spray system, changing or cleaning spray tips, or preparing for cleanup.

3. Position the first spray gun.
  - a. Disengage the trigger cable from the tensioning clamp.

**IMPORTANT:** Always disengage the trigger cable from the tensioning clamp before making any adjustments to the spray gun position.

- b. Loosen the support bar clamps and slide the gun support bar to the desired horizontal position.
- c. Loosen the gun riser clamp and slide the spray gun to the desired vertical position.

**NOTE:** The height of the spray gun affects the width of the spray pattern (i.e., the lower the gun, the smaller the line width). Tip size also affects line width.

4. Install the second gun assembly, if desired. Refer to the installation instructions for the second gun assembly in the Parts List section of this manual.
5. Set the trigger selector for proper spray gun operation. The gun lever on the right handlebar triggers the gun or guns. The selector on the trigger must be set for the first gun, both guns, or the second gun .

**IMPORTANT:** Always turn the trigger lock on the spray gun to the locked position before making any adjustments to the trigger selector. Also, release the trigger cable from its block by lifting the cable up and out of the block. There will be a brief triggering of the gun while releasing the trigger cable.

- a. **First Gun** — The first gun position is with the selector in the left position. Push the lever toward the inside of the frame until the pin engages the left plate.

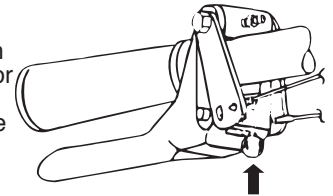

- b. **Both Guns** — The dual gun position is with the selector in the center position. Push the lever toward the center position until the pin engages both plates. The pin must engage both plates.

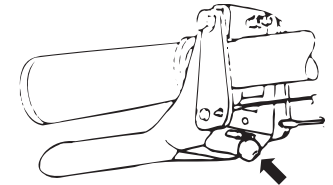

- c. **Second Gun** — The second gun position is with the selector in the right position. Push the lever away from the inside of the frame until the pin engages the right plate.

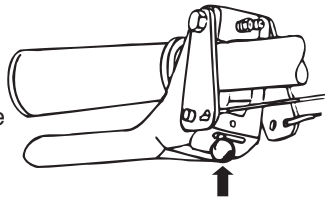

6. Fill the oil cup 1/2 full with Titan Piston Lube (P/N 314-480) supplied by the factory. This extends packing life.
7. Check the hydraulic fluid level daily before starting the sprayer. The hydraulic fluid level should be at the "Full" mark on the dipstick. Refer to the Maintenance section of this manual for hydraulic system maintenance instructions.

**IMPORTANT:** Use of Titan's Coolflo™ Hydraulic Fluid (P/N 430-361) is mandatory in the hydraulic system. Do not use any other hydraulic fluid. Use of any other hydraulic fluid may seriously damage the hydraulic system and will void the warranty.

8. For gas models, check the engine oil level daily before starting the sprayer. The gasoline engine oil level is determined by the engine manufacturer. Refer to the engine manufacturer's service manual supplied with this sprayer.
9. For electric models, use a 20 amp service outlet. Always locate the electric model within 10 to 15 feet of the service outlet. Use a short electric cable and a long paint hose. Any extension cord will create some voltage drop. If an extension cord is necessary, use only a grounded 3-wire #12 extension cord.

**NOTE:** If the sprayer is being operated in an area that is overloaded by other appliances or low voltage conditions, it is important to start the sprayer "unloaded." Tip the electric motor forward so that the belt is loosened and the motor starts without full load. This reduces the amperage draw on starting and may avoid tripping the circuit breaker.

10. Make sure the sprayer is grounded. All sprayers are equipped with a grounding lug. A grounding cable (not supplied) should be used to connect the sprayer to a true earth ground. Check your local electrical regulations for detailed grounding instructions. See the Accessories and Service Kits section near the back of this manual for grounding cable ordering information.

**IMPORTANT: Proper grounding is important. This applies to both gas and electric powered models. The passage of some materials through the nylon fluid hose will build up a static electric charge, which if discharged, could ignite solvent vapors present and create an explosion.**

11. Strain all paints with a nylon strainer to ensure trouble free operation and freedom from frequent cleaning of the inlet screen and gun filter.
12. Make sure the spray area is well ventilated to prevent hazardous operation with volatile solvents or exhaust fumes.

### Preparing a new sprayer

If this sprayer is new, it is shipped with test fluid in the fluid section to prevent corrosion during shipment and storage. This fluid must be thoroughly cleaned out of the system with mineral spirits before you begin spraying.

**IMPORTANT: Always keep the trigger lock on the spray gun in the locked position while preparing the system.**

1. Place the siphon hose into a container of mineral spirits.
2. Place the bleed hose into a metal waste container.
3. Set the pressure to minimum by turning the pressure control knob fully counterclockwise.

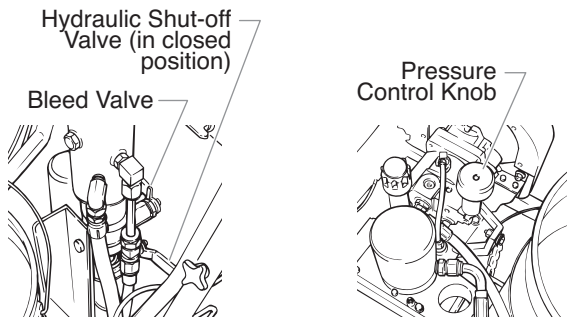

4. Open the hydraulic shut-off valve located on the hydraulic pressure hose. The handle should be in line with the hose.
5. Open the bleed valve by rotating the bleed valve handle fully counterclockwise.
6. Start the engine or turn on the electric motor.

- a. To start the gas engine,
  - move the fuel valve lever to the open position,
  - move the throttle lever to its middle point,
  - move the choke lever to the closed position for a cold engine or to the open position for a warm engine,
  - turn the engine switch to the ON position, and
  - pull the starter rope briskly until the engine starts.
- b. To start the electric motor, move the ON/OFF switch to the ON position.

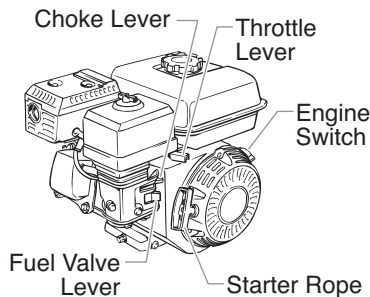

7. Turn the pressure control knob clockwise approximately 1/3 of the way down to increase pressure until the sprayer cycles evenly and solvent flows freely from the bleed hose.
8. Allow the sprayer to run for 15–30 seconds to flush the test fluid out through the bleed hose and into the waste container.
9. Turn off the sprayer.
  - a. To turn off the gas engine,
    - set the pressure to minimum by turning the pressure control knob fully counterclockwise,
    - move the throttle lever to the slow position, and

- turn the engine switch to the OFF position.
- b. To turn off the electric motor,
  - set the pressure to minimum by turning the pressure control knob fully counterclockwise,
  - move the ON/OFF switch to the OFF position.

### Preparing to Paint

Before painting, it is important to make sure that the fluid in the system is compatible with the paint that is going to be used.

**NOTE: Incompatible fluids and paint may cause the valves to become stuck closed, which would require disassembly and cleaning of the sprayer's fluid section.**

**IMPORTANT: Always keep the trigger lock on the spray gun in the locked position while preparing the system.**

1. Place the siphon hose into a container of the appropriate solvent.

**NOTE: If you are spraying a water-based latex, flush with warm, clean water. If you are using any other material, check with the material manufacturer for a compatible solvent.**

2. Place the bleed hose into a metal waste container.
3. Set the pressure to minimum by turning the pressure control knob fully counterclockwise.
4. Open the hydraulic shut-off valve located on the hydraulic pressure hose. The handle should be in line with the hose.
5. Open the bleed valve by rotating the bleed valve handle fully counterclockwise.
6. Start the engine or turn on the electric motor.
  - a. To start the gas engine,
    - move the fuel valve lever to the open position,
    - move the throttle lever to its middle point,
    - move the choke lever to the closed position for a cold engine or to the open position for a warm engine,
    - turn the engine switch to the ON position, and
    - pull the starter rope briskly until the engine starts.
  - b. To start the electric motor, move the ON/OFF switch to the ON position.
7. Turn the pressure control knob clockwise approximately 1/3 of the way down to increase pressure until the sprayer cycles evenly and solvent flows freely from the bleed hose.
8. Allow the sprayer to run for 15–30 seconds to flush the test fluid out through the bleed hose and into the waste container.
9. Turn off the sprayer.
  - a. To turn off the gas engine,
    - set the pressure to minimum by turning the pressure control knob fully counterclockwise,
    - move the throttle lever to the slow position, and
    - turn the engine switch to the OFF position.
  - b. To turn off the electric motor,
    - set the pressure to minimum by turning the pressure control knob fully counterclockwise,
    - move the ON/OFF switch to the OFF position.

**NOTE: Make sure that the spray gun does not have a tip or tip guard installed.**

10. Close the bleed valve by rotating the bleed valve handle fully clockwise.
11. Start the engine or turn on the electric motor.
12. Turn the pressure control knob clockwise approximately 1/3 of the way down to increase pressure.

13. Unlock the gun by turning the gun trigger lock to the unlocked position.



**Ground the gun by holding it against the edge of the metal container while flushing. Failure to do so may lead to a static electric discharge, which may cause a fire.**

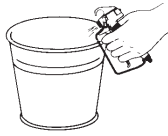

14. Trigger the gun into the metal waste container until the old solvent is gone and fresh solvent is coming out of the gun.

15. Lock the gun by turning the gun trigger lock to the locked position.

16. Set down the gun and increase the pressure by turning the pressure control knob slowly clockwise.

17. Check the entire system for leaks. If leaks occur, follow the "Pressure Relief Procedure" in this manual before tightening any fittings or hoses.

18. Follow the "Pressure Relief Procedure" in this manual before changing from solvent to paint.

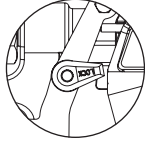

Trigger locked (gun will not spray)



**Be sure to follow the pressure relief procedure when shutting down the sprayer for any purpose, including servicing or adjusting any part of the spray system, changing or cleaning spray tips, or preparing for cleanup.**

## Painting

1. Place the siphon hose into a container of paint.
2. Place the bleed hose into a metal waste container.
3. Set the pressure to minimum by turning the pressure control knob fully counterclockwise.

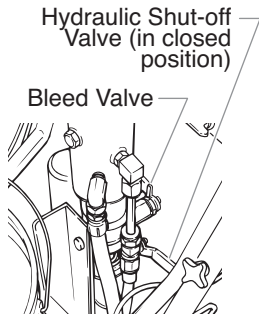

Hydraulic Shut-off Valve (in closed position)

Bleed Valve

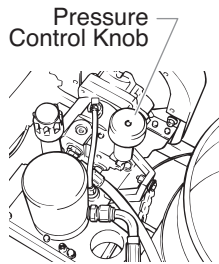

Pressure Control Knob

4. Open the hydraulic shut-off valve located on the hydraulic pressure hose. The handle should be in line with the hose.

5. Open the bleed valve by rotating the bleed valve handle fully counterclockwise.

6. Start the engine or turn on the electric motor.

- a. To start the gas engine,

- move the fuel valve lever to the open position,
- move the throttle lever to its middle point,
- move the choke lever to the closed position for a cold engine or to the open position for a warm engine,
- turn the engine switch to the ON position, and
- pull the starter rope briskly until the engine starts.

- b. To start the electric motor, move the ON/OFF switch to the ON position.

7. Turn the pressure control knob clockwise approximately 1/3 of the way down to increase pressure until the sprayer cycles evenly and paint flows freely from the bleed hose.

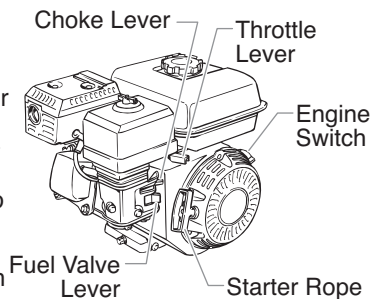

Choke Lever

Throttle Lever

Engine Switch

Fuel Valve Lever

Starter Rope

8. Turn off the sprayer.

- a. To turn off the gas engine,

- set the pressure to minimum by turning the pressure control knob fully counterclockwise,
- move the throttle lever to the slow position, and
- turn the engine switch to the OFF position.

- b. To turn off the electric motor,

- set the pressure to minimum by turning the pressure control knob fully counterclockwise,
- move the ON/OFF switch to the OFF position.

9. Remove the bleed hose from the waste container and place it into the container of paint.

10. Close the bleed valve by rotating the bleed valve handle fully clockwise.

11. Start the engine or turn on the electric motor.

12. Turn the pressure control knob clockwise approximately 1/3 of the way down to increase pressure.

13. Unlock the gun by turning the gun trigger lock to the unlocked position.



**Ground the gun by holding it against the edge of the metal container while flushing. Failure to do so may lead to a static electric discharge, which may cause a fire.**



14. Trigger the gun into the metal waste container until all air and solvent is flushed from the spray hose and paint is flowing freely from the gun.

15. Lock the gun by turning the gun trigger lock to the locked position.

16. Turn off the sprayer.

17. Attach tip guard and tip to the gun as instructed by the tip guard or tip manuals.

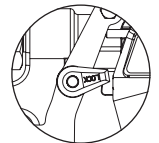

Trigger locked (gun will not spray)



**POSSIBLE INJECTION HAZARD. Do not spray without the tip guard in place. Never trigger the gun unless the tip is in either the spray or the unclog position. Always engage the gun trigger lock before removing, replacing or cleaning tip.**

18. Start the engine or turn on the electric motor.

19. Increase the pressure by turning the pressure control knob slowly clockwise and test the spray pattern on a piece of cardboard. Adjust the pressure control knob until the spray from the gun is completely atomized.

**NOTE: Turning the pressure up higher than needed to atomize the paint will cause premature tip wear and additional overspray.**



## Operating the Front Caster

The front caster on the cart is designed to track the sprayer in either a straight line or allow free motion. Standing behind the sprayer, the trigger on the left handle of the cart controls the operation of the front caster.

1. To lock the front caster in the straight line position, squeeze then release the caster trigger and move the sprayer forward.
2. To allow free motion of the front caster, squeeze and hold the caster trigger.

## Pressure Relief Procedure



**Be sure to follow the Pressure Relief Procedure when shutting the unit down for any purpose, including servicing or adjusting any part of the spray system, changing or cleaning spray nozzles, or preparing for cleanup.**

1. Lock the gun by turning the gun trigger lock to the locked position.
2. Turn off the sprayer.
  - a. To turn off the gas engine,
    - set the pressure to minimum by turning the pressure control knob fully counterclockwise,
    - move the throttle lever to the slow position, and
    - turn the engine switch to the OFF position.
  - b. To turn off the electric motor,
    - set the pressure to minimum by turning the pressure control knob fully counterclockwise,
    - move the ON/OFF switch to the OFF position.
3. Close the hydraulic shut-off valve on the hydraulic pressure hose.
4. Unlock the gun by turning the gun trigger lock to the unlocked position.
5. Hold the metal part of the gun firmly to the side of a metal waste container to ground the gun and avoid a build up of static electricity.
6. Trigger the gun to remove any pressure that may still be in the hose.
7. Lock the gun by turning the gun trigger lock to the locked position.
8. Place the bleed hose into the metal waste container.
9. Open the bleed valve by rotating the bleed valve handle fully counterclockwise.

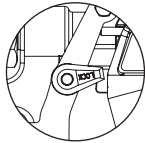

Trigger locked  
(gun will not spray)



## Cleanup



**Special cleanup instructions for use with flammable solvents:**

- Always flush spray gun preferably outside and at least one hose length from spray pump.
- If collecting flushed solvents in a one gallon metal container, place it into an empty five gallon container, then flush solvents.
- Area must be free of flammable vapors.
- Follow all cleanup instructions.

**IMPORTANT: The sprayer, hose, and gun should be cleaned thoroughly after daily use. Failure to do so permits material to build up, seriously affecting the performance of the unit.**



**Always spray at minimum pressure with the gun nozzle tip removed when using mineral spirits or any other solvent to clean the sprayer, hose, or gun. Static electricity buildup may result in a fire or explosion in the presence of flammable vapors.**

1. Follow the "Pressure Relief Procedure" found in the Operation section of this manual.
2. Remove the gun tip and tip guard and clean with a brush using the appropriate solvent.
3. Place the siphon tube into a container of the appropriate solvent.

**IMPORTANT: Use only compatible solvents when cleaning out oil based enamels, lacquers, coal tar, and epoxies. Check with the fluid manufacturer for the recommended solvent.**

4. Place the bleed hose into a metal waste container.
5. Set the pressure to minimum by turning the pressure control knob fully counterclockwise.

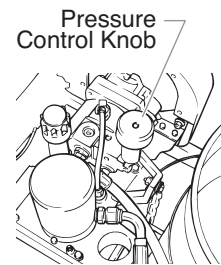
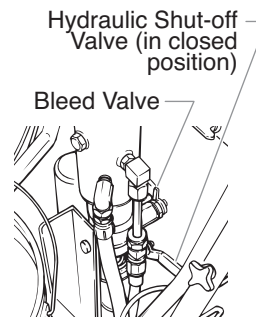

6. Open the hydraulic shut-off valve located on the hydraulic pressure hose. The handle should be in line with the hose.
7. Open the bleed valve by rotating the bleed valve handle fully counterclockwise.
8. Start the engine or turn on the electric motor.
9. Allow the solvent to circulate through the sprayer and flush the paint out of the bleed hose into the metal waste container.
10. Turn off the sprayer.
11. Close the bleed valve by rotating the bleed valve handle fully clockwise.
12. Start the engine or turn on the electric motor.



**Ground the gun by holding it against the edge of the metal container while flushing. Failure to do so may lead to a static electric discharge, which may cause a fire.**



13. Trigger the gun into the metal waste container until the paint is flushed out of the hose and solvent is coming out of the gun.
14. Continue to trigger the spray gun into the waste container until the solvent coming out of the gun is clean.

**NOTE:** For long-term or cold weather storage, pump mineral sprits through the entire system.

15. Follow the "Pressure Relief Procedure" found in the Operation section of this manual.
16. Store the sprayer in a clean, dry area.

**IMPORTANT:** Do not store the unit under pressure.

### Cleaning a Clogged Tip

1. Follow the "Pressure Relief Procedure" in the Operation section of this manual.
2. If the tip clogs, rotate the tip handle 180° until the arrow on the handle is facing the opposite of the spray direction and the handle clicks in the reverse position.
3. Trigger the gun once so that the pressure can blow the clog out. NEVER use the tip in the reverse position for more than ONE trigger pull at a time. This procedure can be repeated until the tip is free of clogging.



The flow from the spray tip is at very high pressure. Contact with any body part may be dangerous. Do not place finger on gun outlet. Do not point the gun at any person. Never operate the spray gun without the proper tip guard.

### Maintenance



Before proceeding, follow the Pressure Relief Procedure outlined previously in this manual. Additionally, follow all other warnings to reduce the risk of an injection injury, injury from moving parts or electric shock. Always unplug the sprayer before servicing!

### Daily Maintenance

Two daily procedures are required for routine operator maintenance on this sprayer:

1. Lubricating the upper packings.
2. Cleaning the rock catcher.

### Lubricating the Upper Packings

1. Clean out the paint that has seeped past the upper packings into the packing oil reservoir above the fluid section.
2. Fill the packing oil reservoir 1/2 full with Piston Lube (P/N 314-480) supplied by the factory. This will extend packing life.



**NOTE:** Do not over-fill the reservoir so that it overflows and drips into the paint.

### Cleaning the Rock Catcher

1. The rock catcher will clog and must be cleaned at least once a day.
2. Loosen the nut that secures the rock catcher to the siphon tube.
3. Remove the rock catcher from the bottom of the siphon tube.
4. Clean thoroughly with the appropriate solvent.

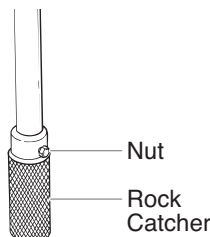

### Maintaining the Filter Assembly

Clean the filter regularly. Dirty or clogged filters can greatly reduce filtering ability and cause a number of system problems including poor spray patterns, clogged spray tips, etc.

#### Cleaning

To clean the filter, perform the following procedure.

1. Follow the "Pressure Relief Procedure" found in the Operation section of this manual.
2. Remove the filter cap assembly and spring.
3. Pull the filter element with ball straight out of the filter body.
4. Clean inside the filter body, filter element with ball, and filter cap assembly using the appropriate solvent.

**NOTE:** Use care in handling parts as dirt, debris, scratches, or nicks may prevent o-rings or gaskets from sealing. This filter element filters from the inside out. Be sure to clean the filter element thoroughly on the inside. Soak in solvent to loosen hardened paint or replace.

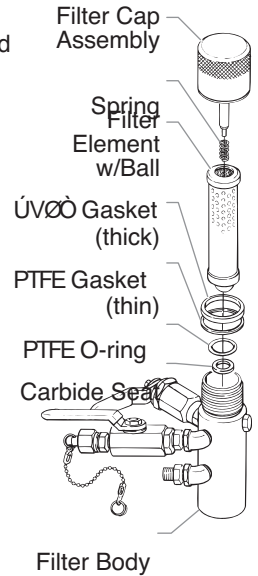

#### Inspection

Inspect all parts of the filter assembly before reassembly.

1. Inspect the ball inside the filter element. If the ball has pressure cuts or scratches, replace the filter element.
  - a. If the ball is cut, remove the PTFE o-ring using an o-ring pick and remove the carbide seat.
  - b. Check the seat for nicks or grooves. If the seat is damaged, replace.

**NOTE:** Removal of the PTFE o-ring will damage the o-ring and require replacement.

2. Remove the spring from the spring guide on the filter cap.
  - a. Measure the length of the spring uncompressed. If it measures less than 3/4" from end to end, replace.
  - b. Push the spring back onto the spring guide until it "snaps" back into position.
3. Inspect the two PTFE gaskets and the PTFE o-ring for deformity, nicks, or cuts. Replace if needed.

**NOTE:** The PTFE gaskets, PTFE o-ring, and spring are packaged in Filter Service Kit P/N 930-050.

#### Reassembly

After cleaning and inspecting all parts, reassemble the filter.

1. Place the carbide seat into the filter body. Make sure the beveled side of the seat is facing up.
2. Place the PTFE o-ring into the groove on the outer diameter of the carbide seat.
3. Place the filter element with ball into the filter body.

**NOTE:** The top and bottom of the filter element with ball are identical.

4. Push the spring back onto the spring guide of the filter cap until it "snaps" back into position, if not already done.
5. Place the thin PTFE gasket onto the step at the top of the filter body.
6. Place the thick PTFE gasket onto the top of the thin gasket.

7. Tighten the filter cap assembly onto the filter body.

## Maintaining the Hydraulic System

**IMPORTANT: Use of Titan's Coolflo™ Hydraulic Fluid is mandatory in the PowrTwin hydraulic system. Do not use any other hydraulic fluid. Use of any other hydraulic fluid may seriously damage the hydraulic system and will void the warranty.**

1. Check the hydraulic fluid daily. It should be at the "Full" mark on the dipstick. If it is low, add only Titan Coolflo™ Hydraulic Fluid (P/N 430-361). Never add or change hydraulic fluid except in a clean, dust-free area. Contamination of the hydraulic fluid will shorten hydraulic pump life and may void warranty.

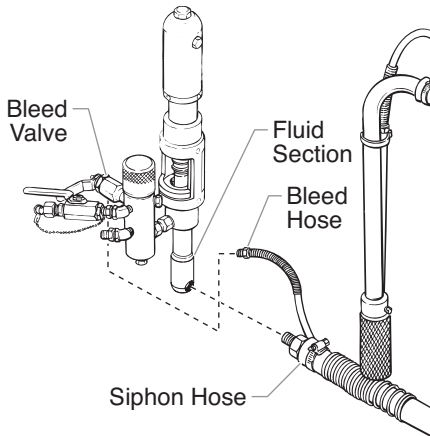

2. Change the hydraulic fluid every twelve months. Drain the old fluid from the tank and fill with 5 quarts of Titan Coolflo™ Hydraulic Fluid. Start the sprayer at just enough pressure to operate the fluid section. Run the sprayer at this low pressure for at least 5 minutes. This removes air from the system. Check the fluid level after this procedure.
3. The hydraulic system has an external, replaceable hydraulic filter. Change the filter every twelve months.
4. The hydraulic pump should not be serviced in the field. If service on the hydraulic pump is required, it must be returned to Titan.

## Maintaining the Fluid Section

If the sprayer is going to be out of service for an extended period of time, it is recommended that following cleanup, a kerosene and oil mixture be introduced as a preservative. Packings may tend to dry out from lack of use. This is particularly true of the upper packing set for which upper packing lubricant Piston Lube (P/N 314-480) is recommended in normal usage.

If the sprayer has been out of service for an extended period of time, it may be necessary to prime the suction by pouring some of the paint solvent into the siphon tube to restart. It is extremely important that the threads on the siphon hose coupling are properly sealed. Any air leakage will produce erratic operation of the sprayer and may damage the system. The up and the down strokes should be approximately equal in time (one should not be faster than the other). A fast up or down stroke may indicate air in the system or malfunctioning valve or seats (see the Troubleshooting section).

## Basic Engine Maintenance (gas engine)

- For detailed engine maintenance and technical specifications refer to the separate gasoline engine manual.
- All service to the engine should be performed by an authorized Honda Power Equipment dealer. To locate a dealer in your area, look in the Yellow Pages of your telephone directory under Gasoline Engines, Garden & Lawn Equipment & Supplies, Lawn Mowers, etc.
- The Honda engine is warranted exclusively by American Honda Motor Co., Inc.
- Use a premium quality motor oil certified to meet or exceed U.S. Automotive requirement SG or SF. SAE 10W30 is recommended for general all temperature use. Other viscosities may be required in other climates.
- Use only a (NGK) BP6ES or BPR6E spark plug. Gap the plug to 0.028 to 0.031 In. (0.7 to 0.8 mm) Always use a spark plug wrench.

### Daily

1. Check engine oil level, and fill as necessary.
2. Check gasoline level, and fill as necessary.



**Always follow the fueling procedure outlined earlier in this manual.**

### First 20 Hours

1. Change engine oil.

### Every 100 Hours

1. Change engine oil.
2. Clean the sediment cup.
3. Clean and re-gap the spark plug.
4. Clean the spark arrestor.

### Weekly

1. Remove the air filter cover and clean the element. In very dusty environments, check the filter daily. Replace the element as needed. Replacement elements can be purchased from your local Honda dealer.

### Engine Operation and Service

1. Clean and oil air filter pad on gasoline engine every 25 hours or once weekly. Do not permit the air intake screen around the fly wheel of the gas engine to load up with paint or trash. Clean it regularly. The service life and efficiency of the gas engine model depends upon keeping the gasoline engine running properly. Change the oil in the engine every 100 hours. Failure to observe this may result in engine overheating. Consult the engine manufacturer's service manual provided.
2. To conserve fuel, service life, and efficiency of the sprayer, always operate the gasoline engine at the lowest RPM at which it runs smoothly without laboring and delivers the amount required for the particular painting operation. Higher RPM does not produce higher working pressure. The gasoline engine is connected to the hydraulic pump by a pulley combination designed to produce full paint delivery at maximum RPM.
3. The warranty on gasoline engines or electric motors is limited to the original manufacturer.

## Replacing the Motor Brushes (electric motor)

Perform this procedure using Motor Brush Kit P/N 978-050. The kit consists of two brushes, two springs, and two clips.

**NOTE: Brushes should be replaced when they are worn to less than 1/2 inch. Check and replace both brushes at the same time.**

1. Remove both inspection covers on the motor.

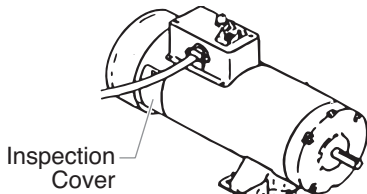

2. Push in the spring clip to unhook it, then pull it out..

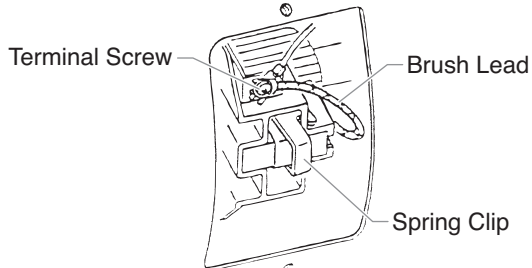

3. Loosen the terminal screw. Pull the brush lead away, but leave the motor lead in place. Remove the brush and spring.
4. Inspect the commutator for burning, excessive pitting or gouging. A black color on the commutator is normal.

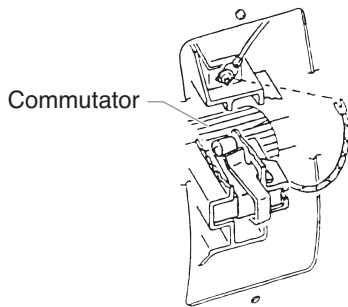

5. Install the new brush so its lead slides in the long slot of the brush holder. Push the terminal under the terminal screw washer. Ensure the motor lead is still connected at the screw. Tighten the screw.

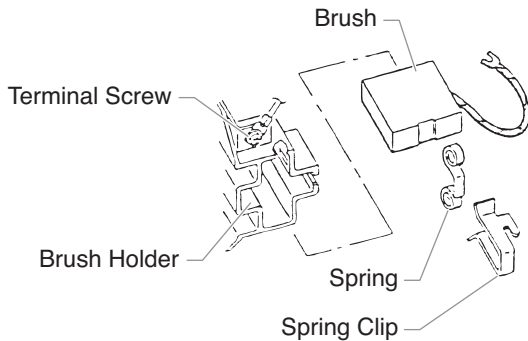

6. Place the spring on the brush as shown above. Push in and hook the spring clip. Repeat this procedure for the other side.
7. Reinstall both inspection covers.



If electric motor overloads and stops running, **IMMEDIATELY** turn the motor off and follow the **Pressure Relief Procedure** in the **Cleanup** section of this manual. Wait until the motor cools (approximately 30 minutes). Then push in the bubble top, manual reset button, turn the motor on and pressurize the system.

**For CSA approved sprayers only: The ON/OFF switch is also the RESET!**

## Adjusting the Tracking of the Front Caster

The front caster is set by the factory to track in a straight line. Use the following procedure if adjustment the caster becomes necessary.

1. Loosen the two hex screws in the top of the caster mounting bracket.
2. Turn the caster mounting bracket slightly in the desired direction.

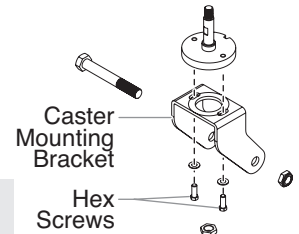

**NOTE: The front caster locking pin must be engaged during tracking adjustment.**

3. Tighten the two hex screws.
4. Check the tracking of the front caster. If the caster does not track straight, repeat the above procedure.

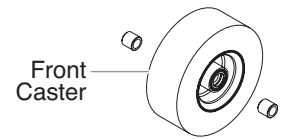

# Troubleshooting

## Airless Gun

### Problem

A. Spitting gun

### Cause

1. Air in system
2. Dirty gun
3. Needle assembly out of adjustment
4. Broken or chipped seat

### Solution

1. Inspect connections for air leaks.
2. Disassemble and clean.
3. Inspect and adjust.
4. Inspect and replace.

B. Gun will not shut off

1. Worn or broken needle & seat
2. Needle assembly out of adjustment
3. Dirty gun

1. Replace.
2. Adjust.
3. Clean.

C. Gun does not spray

1. No paint
2. Plugged filter or tip
3. Broken needle in gun

1. Check fluid supply.
2. Clean.
3. Replace.

## Airless Gun

### Problem

A. Pump delivers on upstroke only or goes up slowly and down fast (commonly called downstroke dive)

### Cause

1. Lower foot valve ball is not seating due to trash or wear
2. Material too viscous to siphon.
3. Air leaking in on siphon side or damaged siphon hose. Siphon may be too small for heavy material.

### Solution

1. Remove foot valve assembly. Clean and inspect. Test foot valve by filling with water; if ball fails to seal the seat, replace ball.
2. Thin material — contact manufacturer for proper thinning procedures.
3. Tighten all connections between pump and paint container. If damaged, replace. Switch to larger diameter siphon set.

B. Pump delivers on down stroke only or goes up fast and down slowly

1. Upper ball is not seating due to trash or wear
2. Lower packing set is worn

1. Check upper seat and ball with water. If ball fails to seal, replace seat.
2. Replace packing set if worn.

C. Pump moves up and down fast, delivering material

1. Material container is empty or material is too thick to flow through siphon hose
2. Bottom ball stuck to foot valve seat
3. Siphon hose is kinked or loose

1. Refill with new material. If too thick, remove siphon hose, immerse fluid section in material, and start pump to prime. Add thinner to material. Change to bigger siphon set. Open bleed valve to remove air and restart pump.
2. Remove foot valve. Clean ball and seat.
3. Straighten.

D. Pump moves up and down slowly when spray gun is shut off

1. Loose connections. Bleed valve is open partially or bleed valve is worn. Lower packing seat is worn.
2. Upper and/or lower ball not seating

1. Check all connections between pump and gun. Tighten as necessary. If material is flowing from bleed hose, close bleed valve or replace, if necessary. Should none of the above be evident, replace lower packing.
2. Reseat balls by cleaning.

E. Not enough fluid pressure at gun

1. Spray tip is worn
2. Outlet filter or gun filter is clogged
3. Low voltage and/or inadequate amperage
4. Hose size or length is too small or too long

1. Replace.
2. Clean or replace filter.
3. Check electrical service. Correct as required.
4. Increase hose size to minimize pressure drop through hose and/or reduce hose length.

F. Pump chatters on up or down stroke

1. Solvent has caused upper packing to swell

1. Replace packing.

# Troubleshooting

## Hydraulic Motor

Problem	Cause	Solution
A. Oil motor stalls at bottom (no unusual heat problems)	<ol style="list-style-type: none"> <li>1. Fluid pump piston seat unthreaded</li> <li>2. Valve sticking or oil motor trip rod shifter assembly separated</li> </ol>	<ol style="list-style-type: none"> <li>1. If connecting rod is okay, remove cylinder head plug and pop valve down. Replace plug and start machine. If machine cycles up and stops at bottom again, then problem is piston seat on fluid pump. Check piston seat. Repair or replace as necessary. If piston seat is okay and problem does not change, check oil motor.</li> <li>2. Remove valve and check for scratches and rough movement when sliding it up and down. Replace valve and spool in this condition. Check trip rod for possible separation and spool in this condition. Check trip rod for possible separation.</li> </ol>
B. Oil motor stalls at top (no unusual heat problems)	<ol style="list-style-type: none"> <li>1. Valve sticking</li> <li>2. Broken spring retainer (valve rod assembly)</li> <li>3. Broken spring or valve rod</li> <li>4. Air in hydraulic motor</li> <li>5. Air in fluid pump</li> </ol>	<ol style="list-style-type: none"> <li>1. Remove valve and check for scratches and rough movement when sliding it up and down. Replace valve and spool in this condition.</li> <li>2. Replace valve rod assembly.</li> <li>3. Replace valve rod assembly.</li> <li>4. Reset valve. Purge Air, generally accomplished by low pressure cycling of motor/pump assembly for 5–10 minutes. Check for causes of air introduction: <ul style="list-style-type: none"> <li>• Loose fittings in tank.</li> <li>• Loose fittings on hydraulic pump.</li> <li>• Loose hose connections.</li> <li>• Low oil in reservoir.</li> </ul> </li> <li>5. Stall at top can occur randomly when fluid pump picks up air. Reset valve. Avoid air in the fluid pump.</li> </ol>
C. Low pressure (okay on down stroke, sluggish on up.stroke — high heat) <b>NOTE: Engine labors on upstroke, idles back at stall on the down stroke.</b>	<ol style="list-style-type: none"> <li>1. Blown piston seal</li> <li>2. Cracked piston</li> </ol>	<ol style="list-style-type: none"> <li>1. Before dismantling oil motor, start machine. With pump cycling under pressure, touch the hydraulic cylinder and the head to see if cylinder or head gets hotter. This will help determine if piston seal is blown or piston nut is broken. If heat is on the head, check the o-rings on spool valve.</li> <li>2. Dismantle oil motor and check piston seals cylinder bore and piston nut. Pay special attention to piston nut. It can be cracked and not show externally.</li> </ol>
D. Low pressure (both strokes - high heat) <b>NOTE: Engine labors at stall on both strokes.</b>	<ol style="list-style-type: none"> <li>1. Blown center o-rings on spool valve</li> <li>2. Bad hydraulic pump</li> </ol>	<ol style="list-style-type: none"> <li>1. Before dismantling oil motor, start machine. With pump cycling under pressure, touch the head to see if the head becomes hotter. This will help determine if center o-ring is blown on spool valve. If hot, remove and replace o-ring.</li> <li>2. Replace hydraulic pump.</li> </ol>

# Troubleshooting

## Spray Patterns

### Problem

A. Tails

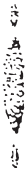

B. Hour glass

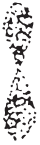

C. Distorted



D. Pattern expanding and contracting (surge)



E. Round pattern



### Cause

1. Inadequate fluid delivery

1. Inadequate fluid delivery

1. Plugged or worn nozzle tip

1. Suction leak  
2. Pulsating fluid delivery

1. Worn tip  
2. Fluid too heavy for tip

### Solution

1. Fluid not atomizing correctly:  
Increase fluid pressure. Change to smaller tip orifice size. Reduce fluid viscosity. Reduce hose length. Clean gun and filter(s). Reduce number of guns using pump.

1. Same as above.

1. Clean or replace nozzle tip.

1. Inspect for suction hose leak.  
2. Change to a smaller tip orifice size. Install pulsation dampener in system or drain existing one. Reduce number of guns using pump. Remove restrictions in system; clean tip screen if filter is used.

1. Replace tip.  
2. Increase pressure. Thin material. Change nozzle tip.



## Consignes de sécurité important • Lire toutes ces consignes avant d'utiliser l'appareil. GARDER CES CONSIGNES.



Indique une situation à risque, laquelle, si elle n'est pas évitée, peut entraîner des blessures graves, voire la mort.



Pour réduire les risques d'incendie ou d'explosion, de choc électrique et de blessure, vous devez lire et comprendre les directives figurant dans ce manuel. Familiarisez-vous avec les commandes et l'utilisation adéquate de l'équipement.



**AVERTISSEMENT – Pour réduire le risque d'incendie ou d'explosion :**



1. Ne pulvérisez pas de matières inflammables ou combustibles près d'une flamme nue, de voyants lumineux ou de sources d'ignition telles que des objets chauds, cigarettes, moteurs, matériel et appareils électriques. Évitez de produire des étincelles en connectant et en déconnectant les cordons électriques.
2. Pour les appareils destinés à n'utiliser que des produits à l'eau – Ne pulvérisez pas et ne les nettoyez pas avec des liquides inflammables. Exclusivement pour usage avec liquides à base d'eau.
3. Pour les appareils destinés à un usage exclusif avec des produits à l'eau ou des produits minéraux de type alcool avec un point d'éclair minimum de 21 °C (70 °F) – Ne pulvérisez pas et ne les nettoyez pas avec des liquides ayant un point d'éclair inférieur à 21 °C (70 °F). Le point d'éclair est la température à laquelle un fluide peut produire suffisamment de vapeur pour s'enflammer.
4. L'écoulement de peinture ou de solvant dans l'équipement peut produire de l'électricité statique. L'électricité statique crée un risque d'incendie ou d'explosion en présence de fumées de peinture ou de solvant. Toutes les pièces du système du pulvérisateur, y compris la pompe, l'ensemble du tuyau, le pistolet de pulvérisation et les objets dans et autour de la zone de pulvérisation doivent être correctement reliés à la terre pour protéger contre les décharges d'électricité statique et les étincelles. N'utilisez que des tuyaux conducteurs ou reliés à la terre pour pulvérisateurs de peinture sous vide à haute pression, spécifiés par le fabricant.
5. Vérifiez que tous les conteneurs ou systèmes de stockage sont reliés à la terre pour éviter les décharges d'électricité statique.
6. Connectez à une prise électrique avec prise de terre et utilisez des rallonges électriques reliées à la terre. N'utilisez pas d'adaptateur 3 à 2.
7. N'utilisez pas de peinture ou de solvant contenant du halon, par exemple, le chlore, les agents antimoussure à l'eau de Javel, le chlorure de méthylène et le trichloroéthane. Ils ne sont pas compatibles avec l'aluminium. Contactez le fournisseur de revêtements pour connaître la compatibilité du matériau avec l'aluminium.
8. La zone de pulvérisation doit toujours être bien aérée. Une bonne quantité d'air frais doit constamment traverser la zone de pulvérisation pour éviter les accumulations de vapeurs inflammables. Le système de pompage doit être placé dans une zone bien aérée. Ne pulvérisez pas le système de pompage.
9. Ne fumez pas dans la zone de pulvérisation.
10. N'actionnez pas d'interrupteurs électriques, de moteurs ou autres dispositifs produisant des étincelles dans la zone de pulvérisation.
11. Maintenez la propreté de la zone et veillez à ce qu'elle ne contienne pas de conteneurs de peinture ou de solvant, de chiffons et autres matières inflammables.

12. Sachez ce que contiennent la peinture et les solvants pulvérisés. Lisez les fiches de sécurité du matériel (MSDS) et les étiquettes apposées sur les conteneurs de peintures et de solvants. Respectez les consignes de sécurité du fabricant de peinture et de solvant.
13. Placez la pompe à une distance minimum de 7,62 mètres (25 pieds) de l'objet à pulvériser, dans une zone bien aérée (ajoutez de la longueur de tuyau si besoin est). Les vapeurs inflammables sont souvent plus lourdes que l'air. La zone près du sol doit être très bien aérée. La pompe contient des pièces qui produisent des arcs et émettent des étincelles pouvant enflammer les vapeurs.
14. Le plastique peut causer des étincelles d'électricité statique. N'accrochez aucun plastique dans une zone de pulvérisation fermée. N'utilisez pas de toiles de protection en plastique quand vous pulvérisez une matière inflammable.
15. Ayez un extincteur en bon état de fonctionnement à portée de main.



**AVERTISSEMENT – Pour réduire le risque de pénétration dans la peau :**



### DANGER :

**Blessure par injection – Le jet de fluide à haute pression produit par cet équipement peut transpercer la peau et les tissus sous-jacents, ce qui produit de graves blessures et peut entraîner une amputation. Consultez immédiatement un médecin. NE TRAITEZ PAS UNE INJECTION COMME UNE SIMPLE COUPURE.**

1. Ne dirigez pas le pistolet sur et ne pulvérisez pas les personnes ou les animaux.
2. N'approchez pas les mains ni d'autres parties du corps de la sortie du produit. Par exemple, ne tentez pas d'arrêter une fuite avec une partie du corps.
3. Utilisez toujours le protège-embout de la buse. Ne pulvérisez pas sans que le protège-embout de la buse ne soit installé.
4. Utilisez exclusivement un embout de buse spécifié par le fabricant.
5. Prenez garde quand vous nettoyez ou que vous changez les embouts de buse. Si l'embout se bouche pendant que vous pulvérisez, verrouillez TOUJOURS la détente du pistolet, arrêtez la pompe et libérez toute la pression avant de réparer ou de nettoyer l'embout ou le protecteur ou avant de changer d'embout. La pression n'est pas libérée par l'arrêt du moteur. La poignée du robinet-valve PRIME/SPRAY (AMORÇAGE/ PULVÉRISATION) doit être placée sur PRIME pour libérer la pression. Consultez la PROCÉDURE DE LIBÉRATION DE PRESSION décrite dans le manuel de la pompe.
6. Ne laissez pas l'appareil sous tension ou sous pression quand vous vous en éloignez. Quand vous n'utilisez pas l'appareil, éteignez-le et libérez la pression conformément aux instructions du fabricant.
7. La pulvérisation à haute pression peut injecter des toxines dans le corps et causer de graves blessures corporelles. Si une telle injection se produisait, consultez immédiatement un médecin.
8. Vérifiez les tuyaux et les pièces pour détecter des signes d'endommagement : une fuite peut injecter le produit dans la peau. Inspectez le tuyau avant chaque emploi. Changez tous les tuyaux ou pièces endommagés.
9. Ce système peut produire une pression de 3300 PSI / 22.8 MPa. N'utilisez que les pièces de rechange ou les accessoires spécifiés par le fabricant et ayant une pression nominale minimum de 3300 PSI. Ceci est valable





## Consignes de sécurité important · Lire toutes ces consignes avant d'utiliser l'appareil. GARDER CES CONSIGNES.

- pour les embouts de pulvérisation, les protecteurs de buse, les pistolets, les rallonges, les raccords et le tuyau.
- Verrouillez toujours la détente quand vous ne pulvérisez pas. Vérifiez que le verrou de la détente fonctionne correctement.
  - Vérifiez que toutes les connexions sont bien serrées avant d'utiliser l'appareil.
  - Sachez comment arrêter l'appareil et le dépressuriser rapidement. Soyez bien familiarisé avec les commandes. La pression n'est pas libérée lorsque le moteur est arrêté. La poignée du robinet-valve PRIME/SPRAY (AMORÇAGE/PULVÉRISATION) doit être placée sur PRIME pour libérer la pression. Consultez la PROCÉDURE DE LIBÉRATION DE PRESSION décrite dans le manuel de la pompe.
  - Retirez toujours l'embout de pulvérisation avant de rincer ou de nettoyer le système.



### AVERTISSEMENT – Pour réduire le risque de blessure :

- Portez toujours les gants, la protection oculaire, les vêtements et un respirateur ou masque appropriés quand vous peignez. Vapeurs dangereuses – Les peintures, solvants, insecticides et autres matières peuvent être dangereux s'ils sont inhalés ou entrent en contact avec le corps. Les vapeurs peuvent provoquer d'importantes nausées, une perte de connaissance ou un empoisonnement.
- Ne travaillez pas et ne pulvérisez pas près d'enfants. Éloignez toujours les enfants de l'équipement.
- Ne travaillez pas avec les bras au-dessus de la tête ni sur un support instable. Appuyez-vous bien sur les deux pieds pour toujours conserver l'équilibre.
- Soyez attentif et regardez ce que vous faites.
- N'utilisez pas l'appareil quand vous êtes fatigué ou sous l'influence de drogues ou d'alcool.
- Ne faites pas de nœuds avec le tuyau et ne le tordez pas trop. Le tuyau à vide peut présenter des fuites suite à l'usure, les nœuds ou les mauvais traitements. Une fuite risque d'injecter du produit dans la peau.
- N'exposez pas le tuyau à des températures ou des pressions supérieures à celles spécifiées par le fabricant.
- N'utilisez pas le tuyau pour tirer ou soulever l'équipement.
- Utilisez la plus basse pression possible pour rincer l'équipement.
- Respectez tous les codes locaux, étatiques et nationaux qui régulent la ventilation, la prévention d'incendies et le fonctionnement.
- Les normes de sécurité du gouvernement des États-Unis ont été adoptées dans la loi Occupational safety and Health Act (OSHA). Ces normes, en particulier la partie 1910 des Normes générales et la partie 1926 des Normes de construction, doivent être consultées.
- Avant chaque emploi, vérifiez tous les tuyaux pour détecter d'éventuelles coupures, fuites, abrasion ou couvercle bombé. Vérifiez l'état ou le mouvement des accouplements. Changez immédiatement le tuyau si l'une de ces conditions est vérifiée. Ne réparez jamais un tuyau de peinture. Remplacez-le par un tuyau conducteur à haute pression.
- Ne pulvérisez pas à l'extérieur par temps venteux.
- Débranchez toujours le cordon électrique de la prise avant de travailler sur l'équipement.

**IMPORTANT: Ne pas soulever par la poignée du chariot lors du chargement ou du déchargement.**

## Sécurité du moteur à essence



**L'État de la Californie reconnaît que les gaz d'échappement de cet appareil contiennent des produits chimiques susceptibles de causer le cancer, des malformations congénitales ou pouvant être nocifs pour le système reproducteur.**

- Les moteurs Honda sont conçus pour être fiables et sécuritaires lorsqu'ils sont utilisés selon les directives. Lire et comprendre le guide d'utilisation de Honda avant de faire fonctionner le moteur. Le non-respect de cet avertissement risque de causer des blessures graves ou d'endommager l'appareil.
- Afin de prévenir les risques d'incendie et d'assurer une ventilation adéquate, garder le moteur à une distance d'au moins un mètre (3 pi) des bâtiments et des autres appareils durant le fonctionnement. Ne pas placer des objets inflammables près du moteur.
- Les enfants et les animaux doivent être tenus à l'écart de la zone de fonctionnement de l'appareil afin d'éviter les risques de brûlures causées par les composants chauds du moteur ou par les équipements utilisés avec le moteur.
- Savoir comment couper le moteur rapidement et bien comprendre le fonctionnement de toutes les commandes. Ne jamais laisser quiconque utiliser le moteur sans lui avoir d'abord fourni les directives appropriées.
- Le carburant est une matière extrêmement inflammable et peut exploser sous certaines conditions.
- Ravitailer en carburant dans un endroit bien aéré une fois le moteur arrêté. Ne pas fumer et s'assurer qu'il n'y ait ni flammes ni étincelles dans la zone de ravitaillement ou d'entreposage du carburant.
- Ne pas trop remplir le réservoir d'essence. Après le ravitaillement, s'assurer que le bouchon du réservoir soit bien fermé et serré.
- Prendre soin de ne pas renverser de carburant lors du ravitaillement, car les vapeurs émanant du carburant ou le carburant déversé accidentellement peuvent s'enflammer. En cas de déversement, s'assurer que l'endroit soit complètement sec avant de démarrer le moteur.
- Ne jamais mettre le moteur en marche dans un endroit fermé ou restreint, car les gaz d'échappement contiennent des matières toxiques, telles que le monoxyde de carbone, susceptibles de provoquer des évanouissements ou même d'entraîner la mort.
- Le silencieux devient très chaud durant le fonctionnement et le demeure pendant un certain temps une fois le moteur arrêté. S'assurer d'attendre quelques minutes avant de toucher au silencieux. Pour éviter les risques de brûlures graves ou d'incendie, laisser le moteur se refroidir avant de le transporter ou de l'entreposer à l'intérieur.
- Ne jamais expédier ou transporter l'appareil lorsque le réservoir est rempli de carburant.



**Ne pas utiliser cet appareil pour vaporiser de l'eau ou de l'acide.**



## Información de seguridad importante • Lea toda la información de seguridad antes de operar el equipo. **GUARDE ESTAS INSTRUCCIONES.**



Indica una situación peligrosa que, de no evitarse, puede causar la muerte o lesiones graves.



Para reducir los riesgos de incendios, explosiones, descargas eléctricas o lesiones a las personas, lea y entienda todas las instrucciones incluidas en este manual. Familiarícese con los controles y el uso adecuado del equipo.



**ADVERTENCIA – Para reducir el riesgo de incendio o explosión:**



1. No pulverice materiales inflamables ni combustibles cerca de llamas desnudas, pilotos o fuentes de ignición como objetos calientes, cigarrillos, motores, equipos eléctricos o electrodomésticos. Evite producir chispas al conectar y desconectar los cables de alimentación.
2. Para unidades que se vayan a utilizar con materiales acuosos — No pulverice ni limpie con líquidos inflamables. Para su uso con líquidos acuosos solamente.
3. Para unidades que se vayan a utilizar solamente con materiales acuosos o de tipo de alcohol mineral con un punto de inflamación mínimo de 21 °C (69,8 °F) — No pulverice ni limpie con líquidos que tengan un punto de inflamación por debajo de 21 °C (69,8 °F). El punto de inflamación es la temperatura a la que un fluido puede producir vapor suficiente como para incendiarse.
4. La pintura o disolvente que pase por el equipo puede producir electricidad estática. La electricidad estática supone un riesgo de incendio o explosión en presencia de emanaciones de pintura o disolvente. Todas las piezas del sistema pulverizador, incluyendo la bomba, el conjunto de mangueras, la pistola pulverizadora y los objetos dentro y alrededor de la zona de pulverización se conectarán a tierra para protegerlos frente a descargas estáticas y chispas. Utilice solamente mangueras para pulverizadores de pintura airless (sin aire) de alta presión conductoras o con toma a tierra especificadas por el fabricante.
5. Compruebe que todos los recipientes y sistemas de recogida están conectados a tierra para evitar descargas eléctricas.
6. Conecte a una salida con toma a tierra y utilice cables alargadores puestos a tierra. No utilice un adaptador de 3 a 2.
7. No utilice pintura o disolvente que contenga hidrocarburos halogenados, como cloro, fungicida blanqueador, cloruro de metileno y tricloroetano. No son compatibles con el aluminio. Póngase en contacto con el proveedor del material para conocer su compatibilidad con el aluminio.
8. Mantenga la zona de pulverización bien ventilada. Asegúrese de que circula aire fresco por la zona para evitar que se acumulen vapores inflamables en el aire de la zona de pulverización. Ponga el conjunto de la bomba en una zona bien ventilada. No pulverice el conjunto de la bomba.
9. No fume en la zona de pulverización.
10. No encienda interruptores de luces, motores ni productos similares que puedan producir chispas en la zona de pulverización.
11. Mantenga la zona limpia y despejada de botes de pintura y disolventes, trapos y otros materiales inflamables.
12. Infórmese del contenido de la pintura y de los disolventes que pulverice. Lea las hojas de datos sobre seguridad de los materiales (MSDS) y las etiquetas en los botes de

pintura y disolvente. Siga las instrucciones de seguridad del fabricante de la pintura y del disolvente.

13. Coloque la bomba al menos a 7,62 metros (25 pies) del objeto que se va a pulverizar en una zona bien ventilada (añada más manguera si fuera necesario). Los vapores inflamables suelen ser más pesados que el aire. La zona del suelo debe estar muy bien ventilada. La bomba contiene piezas que forman arcos que producen chispas y pueden inflamar los vapores.
14. El plástico puede producir chispas estáticas. Nunca utilice plástico para cercar la zona de pulverización. No utilice cortinas de plástico mientras pulveriza material inflamable.
15. Deberá contar con equipos extintores de incendios que funcionen correctamente.



**ADVERTENCIA – Para reducir el riesgo de daños en la piel:**



### PELIGRO:

**Lesión causada por inyección. La corriente de líquido a alta presión que produce este equipo puede perforar la piel y tejidos subcutáneos, pudiendo provocar graves lesiones y posibles amputaciones. Visite a un médico inmediatamente. NO TRATE UNA LESIÓN CAUSADA POR INYECCIÓN COMO UN SIMPLE CORTE.**

1. No apunte con la pistola ni pulverice sobre ninguna persona ni animal.
2. Mantenga las manos y el resto del cuerpo lejos de la descarga. Por ejemplo, no trate de detener fugas con ninguna parte de su cuerpo.
3. Utilice siempre el protector de la boquilla. No pulverice sin el protector en su sitio.
4. Utilice solamente la boquilla especificada por el fabricante.
5. Tenga cuidado al limpiar y cambiar las boquillas. Si la boquilla se atasca durante la pulverización, ponga SIEMPRE el seguro del gatillo de la pistola, apague la bomba y libere toda la presión antes de reparar, limpiar el protector o la boquilla o cambiar la boquilla. La presión no se libera apagando el motor. Para liberar la presión hay que poner la manija de la válvula PRIME/SPRAY (cebar/pulverizar) en PRIME. Consulte el Procedimiento para liberar presión que se describe en el manual de la bomba.
6. No deje el aparato con corriente ni con presión cuando nadie esté pendiente de ella. Cuando no utilice el aparato, apáguelo y libere la presión siguiendo las instrucciones del fabricante.
7. La pulverización a alta presión puede inyectar toxinas en el cuerpo y producir daños graves en el mismo. En caso de que esto ocurra, visite a un médico inmediatamente.
8. Compruebe las mangueras y las piezas en busca de daños; una fuga puede inyectar material en la piel. Inspeccione la manguera antes de cada uso. Sustituya las mangueras o las piezas dañadas.
9. Este sistema es capaz de producir 3300 PSI / 22.8 MPa. Utilice solamente piezas de repuesto o accesorios especificados por el fabricante y con una capacidad nominal de 3300 PSI como mínimo. Entre ellos se incluyen boquillas pulverizadoras, protectores para las boquillas, pistolas, alargadores, racores y mangueras.
10. Ponga siempre el seguro del gatillo cuando no esté pulverizando. Verifique que el seguro del gatillo funciona correctamente.
11. Antes de utilizar el aparato, verifique que todas las conexiones son seguras.



## Información de seguridad importante • Lea toda la información de seguridad antes de operar el equipo. **GUARDE ESTAS INSTRUCCIONES.**

12. Aprenda a detener el aparato y a liberar la presión rápidamente. Familiarícese a conciencia con los controles. La presión no se libera apagando el motor. Para liberar la presión hay que poner la manija de la válvula PRIME/SPRAY (cebar/pulverizar) en PRIME. Consulte el Procedimiento para liberar presión que se describe en el manual de la bomba.
13. Quite siempre la boquilla pulverizadora antes de enjuagar o limpiar el sistema.



### **ADVERTENCIA – Para reducir el riesgo de lesiones:**

1. Cuando pinte, lleve siempre guantes, protección para los ojos, ropa y un respirador o máscara adecuados. Vapores peligrosos: Las pinturas, disolventes, insecticidas y otros materiales pueden ser perjudiciales si se inhalan o entran en contacto con el cuerpo. Los vapores pueden producir náuseas intensas, desmayos o envenenamiento.
2. Nunca utilice el aparato ni pulverice cerca de niños. Mantenga el equipo alejado de los niños en todo momento.
3. No se estire demasiado ni se apoye sobre un soporte inestable. Mantenga los pies bien apoyados y el equilibrio en todo momento.
4. No se distraiga y tenga cuidado con lo que hace.
5. No utilice el aparato si está fatigado o se encuentra bajo la influencia del alcohol o de las drogas.
6. No retuerza ni doble la manguera en exceso. En la manguera airless pueden aparecer fugas a causa del desgaste, de retorcimientos o de un mal uso. Una fuga puede inyectar material en la piel.
7. No exponga la manguera a temperaturas o presiones que superen las especificadas por el fabricante.
8. No utilice la manguera como elemento de fuerza para tirar del equipo o levantarlo.
9. Utilice la presión más baja posible para enjuagar el equipo.
10. Cumpla todos los reglamentos locales, estatales y nacionales pertinentes relativos a ventilación, prevención de incendios y funcionamiento.
11. Las normas sobre seguridad del gobierno de los Estados Unidos se han adoptado al amparo de la Ley de salud y seguridad ocupacional (OSHA). Deben consultarse tres normas, particularmente la sección 1910 de las Normas generales y la sección 1926 de las Normas sobre construcción.
12. Cada vez que vaya a utilizar el equipo, compruebe antes todas las mangueras en busca de cortes, fugas, abrasión o bultos en la cubierta. Compruebe el movimiento de los acoplamientos y si están dañados. Sustituya inmediatamente una manguera si descubre alguna de estas anomalías. No repare nunca una manguera de pintura. Sustitúyala por una manguera conductora a alta presión.
13. No pulverice al aire libre si hace viento.
14. Desenchufe siempre el cable antes de trabajar en el equipo.

**IMPORTANTE: No cargue el equipo por el asa del carrito durante la carga y descarga.**

## **Seguridad con los motores de gasolina**



**El escape del motor de esta unidad contiene químicos que el Estado de California ha determinado causan cáncer, defectos de nacimiento u otros daños al sistema reproductor.**

1. Los motores Honda están diseñados para proporcionar un servicio seguro y fiable, si se utilizan de acuerdo a las instrucciones. Lea y entienda las instrucciones del Manual del Propietario de Honda antes de utilizar el motor. De lo contrario, podría causar lesiones personales o daño al equipo.
2. Para evitar peligros de incendio y para proporcionar una ventilación adecuada, mantenga el motor por lo menos a 1 metro de los edificios y de otro equipo durante su uso. No coloque objetos inflamables cerca del motor.
3. Mantenga a los niños y las mascotas alejados de la zona de trabajo, pues existe la posibilidad de quemaduras causadas por los componentes calientes del motor o lesiones causadas por cualquier equipo en el que se utilice el motor.
4. Sepa cómo apagar el motor rápidamente y comprenda el funcionamiento de todos los controles. Nunca permita a nadie operar el motor sin las instrucciones apropiadas.
5. La gasolina es extremadamente inflamable y es explosiva bajo ciertas condiciones.
6. Llene el tanque de combustible en un lugar bien ventilado y con el motor apagado. No fume ni permita que haya llamas ni chispas en la zona de llenado ni en donde se almacena el combustible.
7. No llene en exceso el tanque de combustible. Después de ponerle combustible, asegúrese de que la tapa del tanque esté cerrada completamente.
8. Tenga cuidado de no derramar el combustible. Los gases del combustible o el combustible derramado pueden encenderse. Si se derrama combustible, asegúrese de que la zona esté seca antes de encender el motor.
9. Nunca utilice el motor en un lugar encerrado o confinado. El escape contiene gas de monóxido de carbono venenoso; la exposición a este gas puede causar pérdida del conocimiento y puede conducir a la muerte.
10. El escape se calienta mucho durante su uso y permanece caliente durante un rato después de apagar el motor. Asegúrese de no tocar el escape cuando esté caliente. Para evitar quemaduras graves o peligros de incendio, deje que el motor se enfríe antes de transportarlo o guardarlo bajo techo.
11. Nunca envíe ni transporte la unidad con gasolina en el tanque.



**No utilice este equipo para rociar agua o ácido.**

# Parts Lists and Service Instructions

## Main Assembly — Gas Model



Item	Part #	Description	One Gun 759-491	Two Guns 759-493
1	779-098	Filter assembly .....	1	1
2	759-138	Second gun kit with gun .....		1
	759-139	Second gun kit without gun .....		1
3	550-290	Airless Gun .....	1	2
4	235-117	Motor/pump assembly .....	1	1
5	759-130	12 gallon hopper .....	1	1
6	103-841	Siphon hose assembly .....	1	1
7	840-218	Bleed line assembly w/ valve .....	1	1
8	506-145	Convertkit, 3.5 HP, Gasoline .....	1	1
9	779-564	Cart assembly .....	1	1
10	665-xxxx	SC-6 stripping tips (optional, see tip chart near the end of this section)		

# Hydraulic System Assembly

(P/N 779-027)

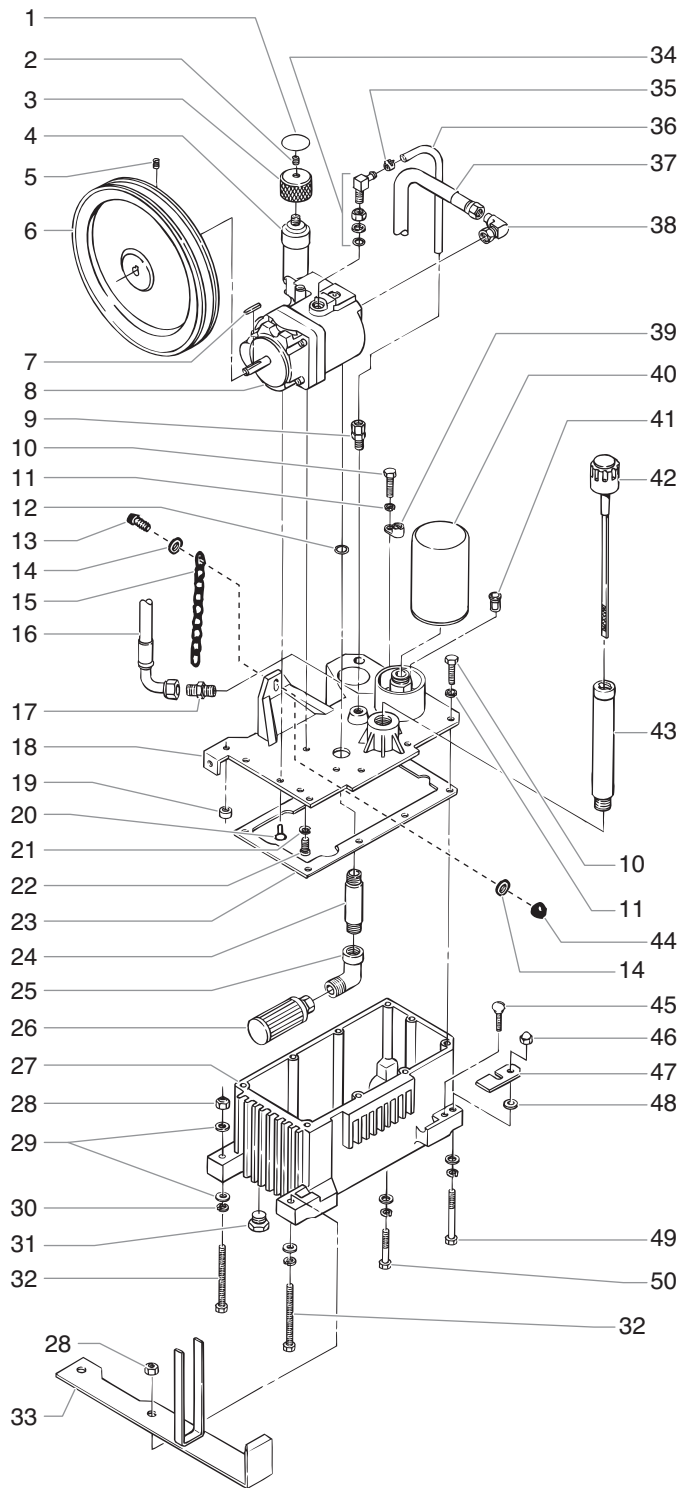

Item	Part #	Description	Quantity
1	313-755	Knob decal.....	1
2	862-414	Set screw.....	1
3	448-243	Pressure control knob.....	1
4	449-286	Pressure compensator.....	1
5	860-520	Set screw.....	1
6	448-250	Pulley/fan assembly.....	1
7	448-494	Key, pump (.156 x .156 x 13/16).....	1
8	449-751	Hydraulic pump (includes item 4).....	1
9	431-042	Tube connector.....	1
10	858-636	Screw, HH.....	8
11	858-002	Lock washer.....	10
12	325-031	O-ring.....	1
13	860-528	Screw.....	1
14	860-002	Washer.....	2
15	424-283	Chain.....	1
16	424-236	Return hose assembly.....	1
17	451-029	Fitting.....	1
18	449-616	Tank cover.....	1
19	858-609	Clinch nut.....	1
20	858-621	Socket screw.....	2
21	859-001	Washer.....	2
22	858-624	Screw.....	2
23	449-605	Tank gasket.....	1
24	112-208	Nipple.....	1
25	472-500	Elbow, street.....	1
26	448-208	Inlet screen.....	1
27	449-623	Hydraulic tank.....	1
28	862-410	Flex lock nut.....	2
29	862-001	Flat washer.....	6
30	862-002	Lock washer.....	4
31	449-212	Plug.....	1
32	862-499	Screw, 4".....	2
33	449-985	Shield.....	1
34	192-228	Elbow.....	1
35	449-126	Hose clamp.....	1
36	420-250	Tubing, PTFE.....	1
37	424-284	Pressure hose assembly.....	1
38	192-051	Elbow.....	1
39	101-205	Ground lug.....	1
40	451-220	Hydraulic filter.....	1
41	449-609	Hydraulic by-pass.....	1
42	449-626	Hydraulic fluid cap/dipstick.....	1
43	449-614	Tube assembly.....	1
44	860-502	Nut.....	1
45	862-438	Thumb screw.....	1
46	862-402	Acorn nut.....	1
47	449-107	Mounting plate retainer.....	1
48	449-135	Spacer.....	1
49	862-403	Screw, 3.5".....	1
50	862-493	Screw, 3".....	1
51	451-121	Elbow (not shown).....	1
52	941-555	Ball valve (not shown).....	1

## Torque and Sealant Guide

Item	Description
5	Use blue Loctite on threads
9	Use hydraulic sealant
10	Torque to 20 FT/LBS (28 N/m)
17	Use hydraulic sealant
20	Use blue Loctite on threads
20	Torque to 8 FT/LBS (11 N/m)
22	Torque to 8 FT/LBS (11 N/m)
24	Use hydraulic sealant
25	Use hydraulic sealant
26	Use hydraulic sealant
32	Torque to 15 FT/LBS (20,5 N/m)
49	Torque to 15 FT/LBS (20,5 N/m)
50	Torque to 15 FT/LBS (20,5 N/m)

## Gas Convertokit (P/N 506-145)

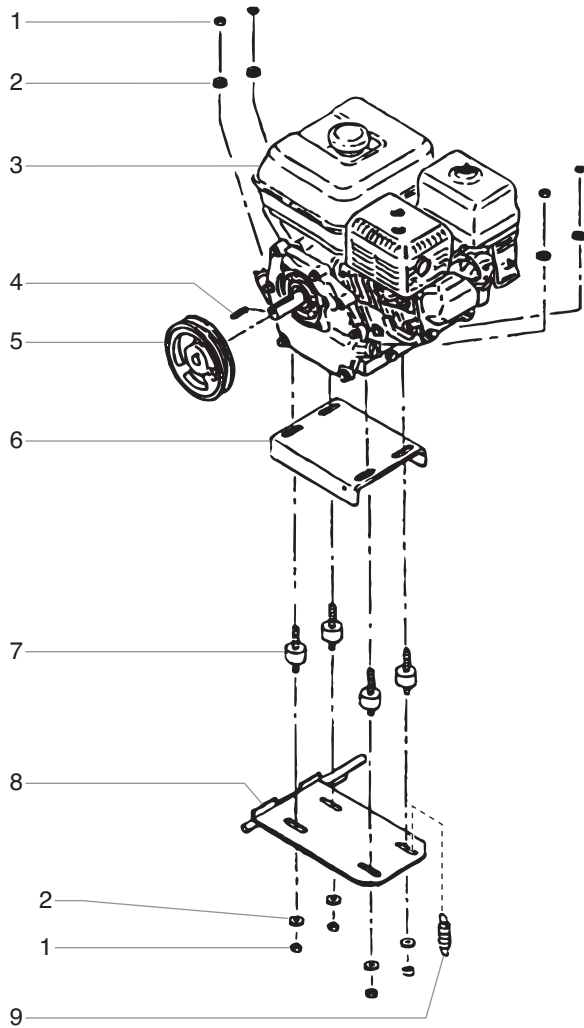

Item	Part #	Description	Quantity
1	860-502	Nut, stop .....	8
2	860-004	Washer, flat .....	8
3	750-200	Engine, gas 3.5 HP .....	1
4	980-307	Key .....	1
5	448-221	Pulley .....	1
6	449-144	Bracket .....	1
7	449-165	Vibration pad .....	4
8	449-219	Mounting plate .....	1
9	424-255	Spring .....	1
10	431-134	Belt, "V" (not shown, not part of assembly)	

## DC — Electric Convertokits

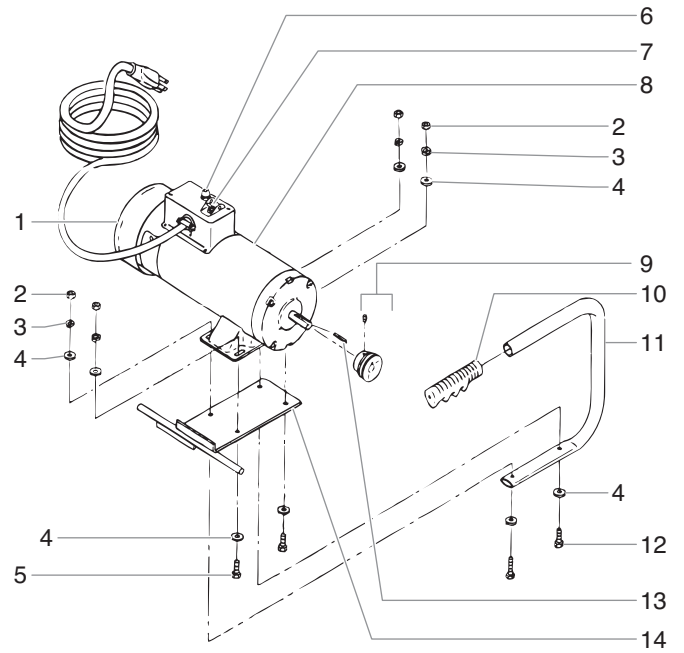

Item	Part #	Description	506-217 Qty.	506-214 Qty.
1	506-259	Cover .....	1	1
2	860-501	Nut, Stop .....	4	4
3	860-002	Washer, Lock .....	4	4
4	860-004	Washer, Flat .....	8	8
5	860-535	Screw .....	2	2
6	978-040	Circuit breaker reset .....	1	
7	506-257	Circuit breaker reset .....	1	1
8	506-260	ON/OFF switch .....	1	1
8	978-350	Motor, DC-Electric, 2 HP 50/60 Hz, 115 V .....	1	
	978-351	Motor, DC-Electric, 2 HP 50/60 Hz, 220 V .....	1	1
9	977-227	Pulley .....	1	1
10	590-068	Grip, Handle .....	1	1
11	335-017	Handle .....	1	1
12	860-552	Screw .....	2	2
13	980-307	Key .....	1	1
14	448-337	Mounting Plate .....	1	1
15	424-285	Belt, "V" (not shown, not part of assembly)		

### Siphon Hose Assembly (P/N 103-841)

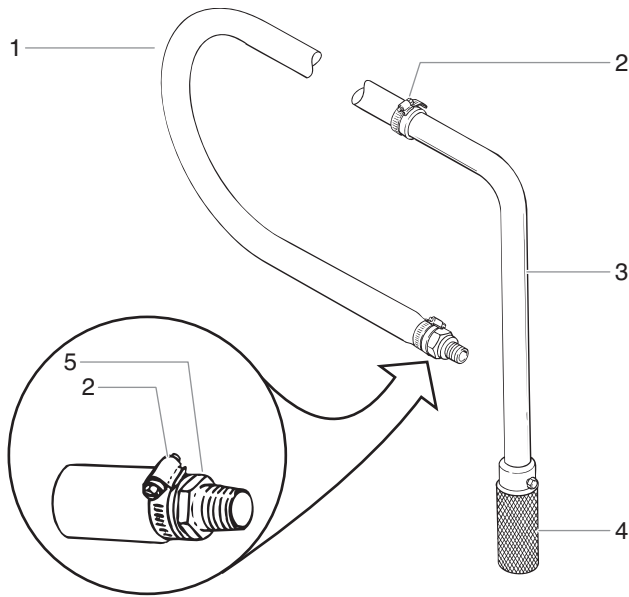

Item	Part #	Description	Quantity
1	779-191	Hose, 52" .....	1
2	103-679	Hose clamp .....	2
3	103-575	Tube .....	1
4	103-627	Intake screen .....	1
5	194-761	Adapter .....	1

### Bleed Hose Assembly with Valve

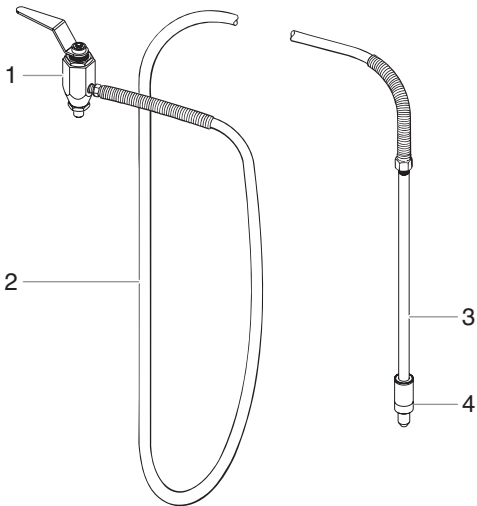

Item	Part #	Description	Quantity
1	944-030	Bleed valve assembly .....	1
2	500-516	Hose assembly .....	1
3	103-300	Bleed tube (includes item 4) .....	1
4	103-118	Diffuser .....	1

### Bleed Valve Assembly (P/N 944-030)

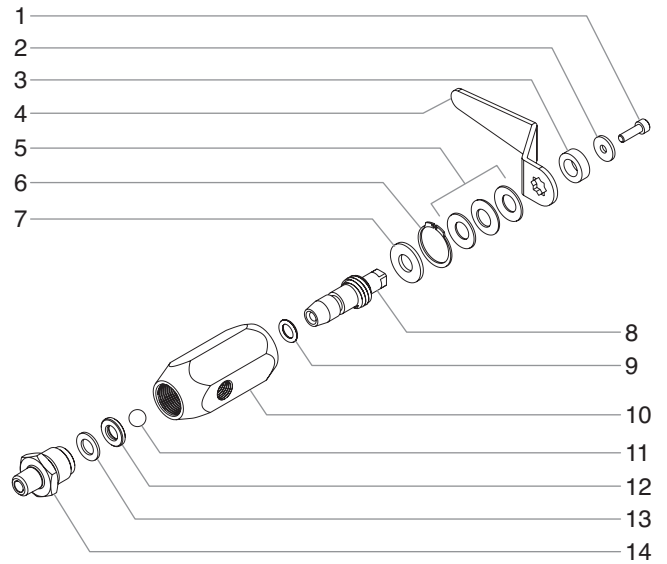

Item	Part #	Description	Quantity
1	944-047	Hex screw .....	1
2	944-029	Flat washer .....	1
3	944-046	Spacer .....	1
4	944-034	Valve handle .....	1
5	944-035	Spring washer .....	3
6	944-036	Retaining ring .....	1
7	944-029	Valve washer .....	1
8	944-011	Valve stem .....	1
9	944-038	Stem o-ring .....	1
10	944-031	Valve housing .....	1
11	944-039	Ball .....	1
12	944-043	Valve seat .....	1
13	944-044	Valve seal .....	1
14	944-013	Valve seat retainer .....	1

### Wheel Assembly

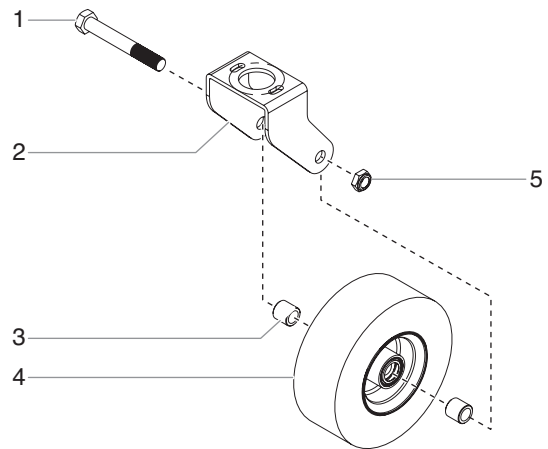

Item	Part #	Description	Quantity
1	779-018	Axle .....	1
2	779-011	Frame .....	1
3	779-017	Spacer .....	2
4	779-016	Wheel .....	1
5	779-019	Lock nut .....	1

# Cart Assembly (P/N 779-564)

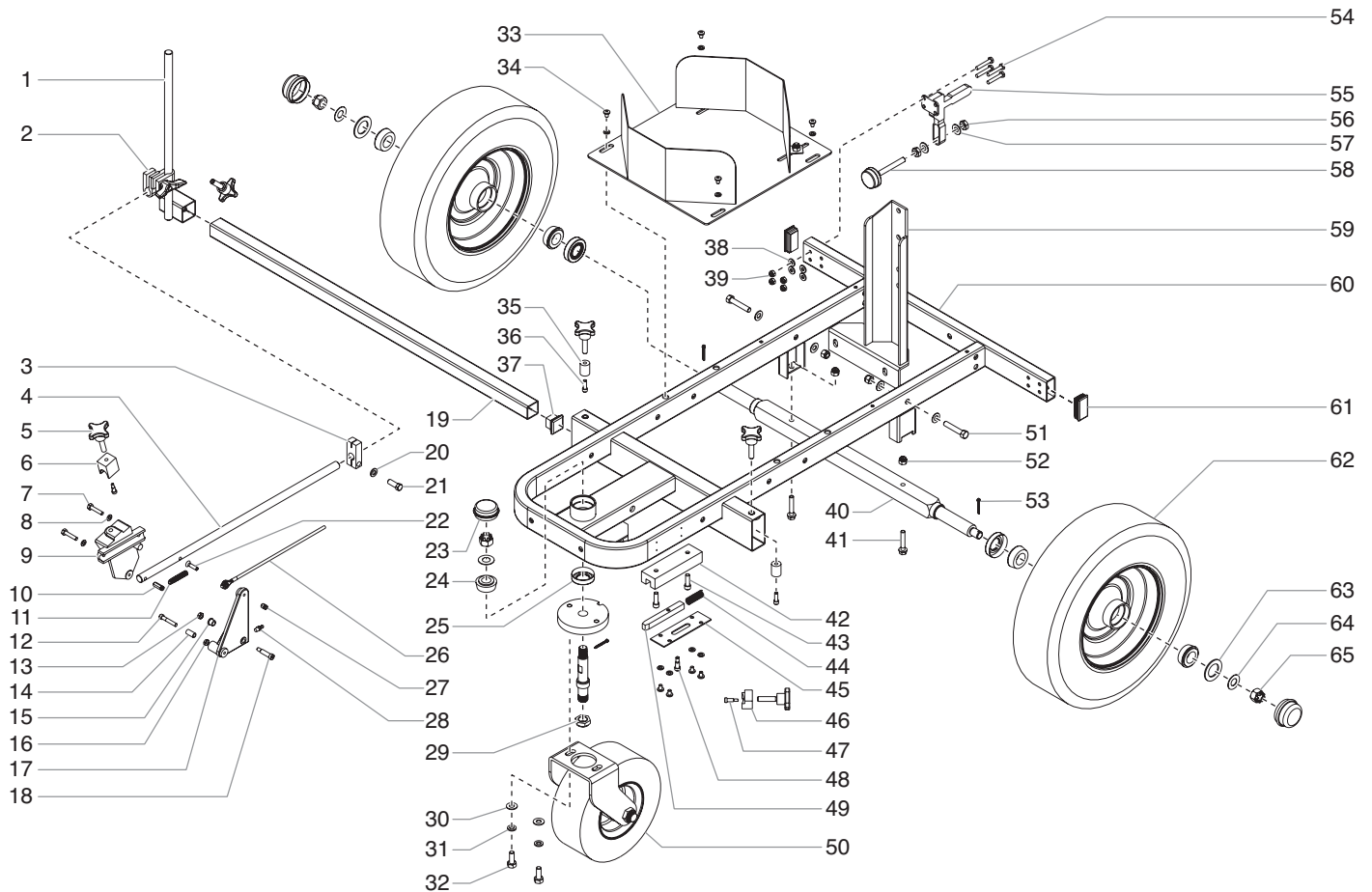

Item	Part #	Description	Quantity	Item	Part #	Description	Quantity
1	757-089	Gun riser weldment .....	1	34	700-784	Screw.....	8
2	779-083	Clamp assembly .....	1	35	757-022	Clamp rod.....	2
3	424-226	Cable mounting clamp.....	1	36	759-110	Screw.....	2
4	424-224	Support arm.....	1	37	757-055	Plastic end cap .....	1
5	756-034	Clamping knob.....	5	38	770-601	Flat washer.....	4
6	779-106	Clamp block.....	1	39	770-144	Lock nut, 1/4".....	7
7	858-644	Screw.....	2	40	779-035	Axle.....	1
8	858-002	Lock washer, 1/4".....	10	41	761-178	Hex screw.....	2
9	424-233	Gun holder.....	1	42	779-118	Guide block.....	1
10	759-057	Spring holder (long).....	1	43	730-148	Socket screw.....	2
11	759-058	Return spring.....	1	44	756-087	Lock spring.....	1
12	858-653	Shoulder screw.....	1	45	759-014	Block cover.....	1
13	858-601	Jam nut.....	1	46	779-046	Block.....	1
14	424-249	Sleeve bearing.....	1	47	756-037	Shoulder screw.....	2
15	424-248	Flange bearing.....	2	48	759-016	Shoulder screw.....	1
16	858-603	Jam nut.....	1	49	779-138	Caster lock pin.....	1
17	424-202	Lever.....	1	50	-----	Wheel assembly (see separate listing).....	1
18	860-936	Shoulder screw.....	1	51	862-468	Screw.....	2
19	757-014	Gun support bar.....	1	52	763-549	Lock nut, 5/16".....	2
20	862-002	Lock washer.....	1	53	756-079	Cotter pin.....	3
21	862-436	Screw.....	1	54	858-652	Screw.....	4
22	703-079	Screw.....	1	55	424-271	Brake clamp.....	1
23	779-086	Dust cap.....	1	56	862-401	Nut.....	2
24	779-068	Taper bearing.....	2	57	860-004	Flat washer.....	2
25	779-085	Taper bearing seal.....	1	58	424-269	Brake pad.....	1
26	779-152	Gun cable.....	1	59	779-080	Pump support.....	1
27	759-056	Spring holder (short).....	1	60	779-025	Frame.....	1
28	424-229	Grease fitting.....	1	61	779-121	Plastic plug.....	2
29	779-019	Lock nut, 3/4".....	1	62	757-050	Rear wheel.....	2
30	862-001	Flat washer.....	2	63	176-919	Washer.....	2
31	862-002	Lock washer.....	2	64	756-080	Spring washer.....	3
32	862-436	Hex screw.....	2	65	756-078	Castle nut.....	3
33	779-563	Bucket holder.....	1				



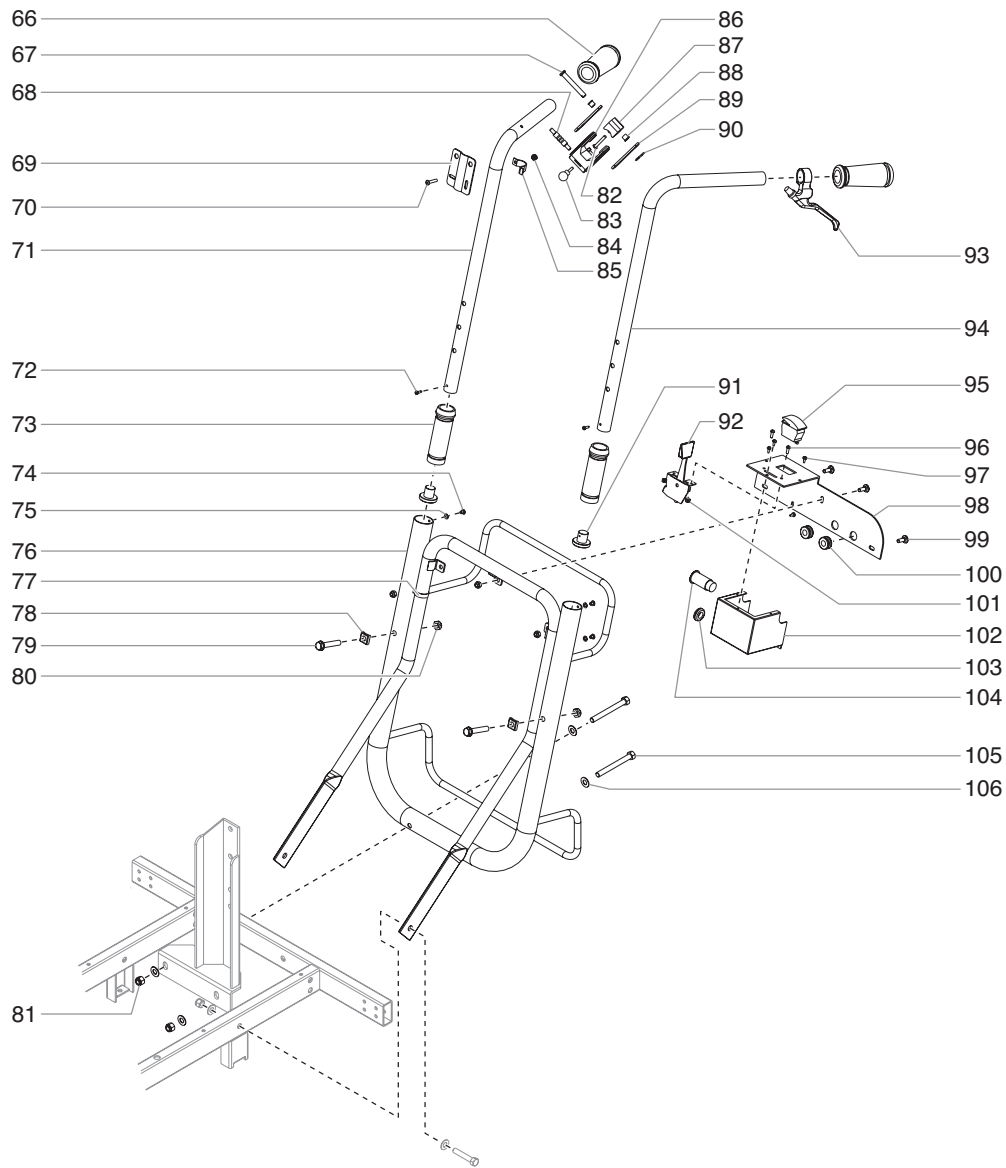

Item	Part #	Description	Quantity
66	424-245	Grip.....	2
67	759-015	Clevis pin.....	1
68	424-227	Selector spool.....	1
69	759-031	Cable guide plate.....	1
70	757-092	Screw.....	1
71	779-054	Handle bar, right.....	1
72	704-137	Screw.....	2
73	590-504	Handle sleeve.....	2
74	856-921	Screw.....	4
75	856-002	Lock washer.....	4
76	779-055	Handle assembly.....	1
77	424-247	Cable clip.....	1
78	779-104	Screw block.....	2
79	862-468	Screw.....	2
80	862-411	Nut.....	2
81	862-410	Lock nut, 3/8".....	4
82	856-744	Screw.....	2
83	759-033	Clamp knob.....	1
84	220-001	Lock nut.....	1
85	759-035	Strap.....	1
86	424-203	Trigger.....	1
87	424-219	Mounting block.....	1

Item	Part #	Description	Quantity
88	424-218	Flange bearing.....	2
89	424-217	Lever plate.....	2
90	759-034	Cotter pin.....	1
91	779-059	Handle guide.....	2
92	779-089	Throttle control.....	1
93	779-251	Trigger lever.....	1
94	779-056	Handle bar, left.....	1
95	779-090	Kill switch.....	1
96	700-139	Screw.....	2
97	779-193	Screw.....	4
98	779-057	Control plate.....	1
99	770-712	Carriage screw.....	3
100	800-036	Grommet.....	2
101	855-914	Lock nut.....	2
102	779-119	Control panel housing.....	1
103	773-932	Grommet.....	1
104	779-177	12V plug adapter.....	1
105	862-498	Screw.....	2
106	862-001	Flat washer.....	8
107	779-268	Caster cable (not shown).....	1
108	779-152	Gun cable (not shown).....	1

# Hydraulic Motor

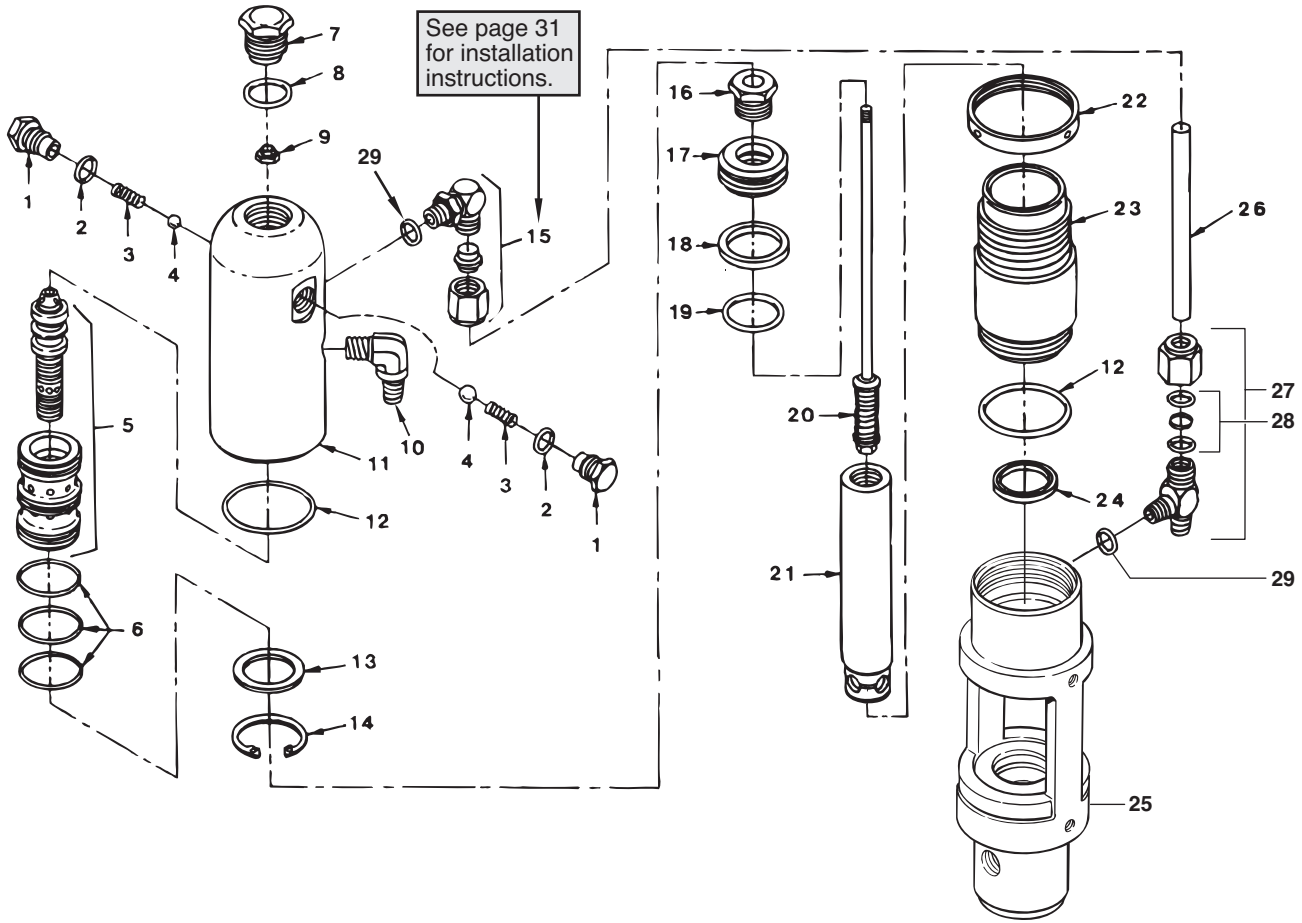

Item	Part #	Description	Quantity
1	235-018	Trip retainer .....	2
2	141-007	O-ring.....	2
3	325-005	Trip spring.....	2
4	569-016	Ball, SS.....	2
5	441-908	Spool / sleeve set.....	1
6	441-152	O-ring.....	3
7	235-030	Cylinder head plug.....	1
8	441-217	O-ring.....	1
9	858-811	Flex lock nut .....	1
10	451-121	Elbow, 90° .....	1
11	235-112	Cylinder head .....	1
12	431-032	O-ring.....	2
13	431-053	Sleeve retainer .....	1
14	431-054	Retainer ring.....	1
15	192-000	Elbow .....	1
16	235-022	Piston retainer screw .....	1
17	235-014	Piston.....	1
18	235-027	Piston seal.....	1
19	235-026	O-ring.....	1
20	235-021	Valve rod assembly .....	1
21	235-948	Piston rod .....	1
22	235-001	Lock ring .....	1
23	235-007	Cylinder .....	1
24	235-028	Rod seal .....	1
25	235-123	Motor/pump block.....	1
26	235-029	Motor tube .....	1
27	235-125	Tee .....	1
28	431-019	O-ring kit.....	1
29	700-499	O-ring.....	2

## Motor Service Kit — Minor (P/N 235-050)

Item	Part #	Description	Quantity
2	141-007	O-ring.....	2
3	325-005	Trip spring.....	2
4	569-016	Ball, SS.....	2
6	441-152	O-ring.....	3
8	441-217	O-ring.....	1
9	858-811	Flex lock nut .....	1
12	431-032	O-ring.....	2
18	235-027	Piston seal.....	1
19	235-026	O-ring.....	1
24	235-028	Rod seal .....	1

## Servicing the Hydraulic Motor

Perform this procedure using the necessary parts from Motor Service Kit — Minor (P/N 235-050). If the hydraulic motor is operable, start the machine and jog the piston rod (19) into its top position.

**NOTE:** Servicing of the hydraulic motor should be carried out in a clean, dust free area only. Any dust or metallic particles left in the motor or entering it on reassembly may damage the critical parts and affect its service life and warranty. All parts should be inspected for absolute cleanliness.

## Disassembling the Hydraulic Motor

1. Disconnect the pressure hose from the elbow (36 and 37 in Hydraulic System parts list) on the back of the hydraulic pump.
2. Remove the two mounting screws and two lock washers that attach the motor/pump assembly to the pump support on the cart.

3. Place the motor/pump assembly in a vise, holding it securely by the motor/pump block (25).
4. Remove cylinder head plug (7).
5. Loosen lock ring (22) with a spanner wrench and unthread tube retaining nut on tee (27). Loosen tube retaining nut on elbow (15). Slide the nut down. Push motor tube (26) into tee (27) far enough to clear elbow (15). Slowly unthread cylinder head (11) and lift it just high enough above the cylinder (23) to reach the valve rod assembly (20) with vise grip pliers.
6. The piston rod (21) should be near the top of its stroke for disassembly. It may be necessary to use a wood or nylon driver to push the piston rod up to its top position.
7. Grip the valve rod securely with vise grip pliers and then remove the FlexLoc nut (9) from the top of the valve rod assembly (20). Be careful that spool (5) does not fall. The cylinder head (11) can now be lifted off. Unthread the cylinder (23) from the motor/pump block (25). Note: An extra lock ring (22) can be used to jam the two lock rings together on the cylinder and a pipe wrench can be used to unthread the cylinder (23) from the motor/pump block (25).
8. To remove the connecting pin, slide the retaining ring down with a small screwdriver, and then push the connecting pin out.
9. Remove the piston rod assembly from the motor/pump block (25).
10. Remove rod seal (24), being extremely careful not to scratch the seal groove in the motor/pump block (25).
11. Place the piston retainer screw (16) on the piston rod assembly in a vise. Slide a long bar through the hole at the base of the piston rod for leverage, and unthread the piston rod from the piston retainer screw.
12. Remove piston (17) and lift out valve rod assembly (20).
13. Remove piston seal (18) and o-ring (19).
14. Remove trip retainers (1), trip springs (3), and balls (4) from cylinder head (11). Remove o-rings (2) from trip retainers (1).
15. Remove retaining ring (14) and sleeve retainer (13). Gently tap spool/sleeve set (5) out of cylinder head (11) using a wood or nylon rod.
16. Inspect piston rod (21) and cylinder (23) for wear, scratches, and dents. Replace if damaged.
17. Inspect spool valve (5) for wear. Replace if necessary. spool valve should move smoothly and freely with no force by holding in a vertical position. If it does not, it can cause the motor to stall.

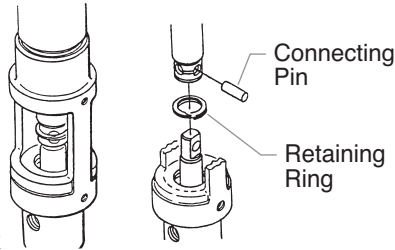

4. Replace lower seal (24) in motor/pump block (25). Be sure the open portion of the seal is facing upward (V). This seal requires no special tool.
5. Place piston rod (21) in vise. Inspect valve rod assembly (20) for any damage. Make sure the lock nut at the bottom of the valve rod assembly (20) is secure. DO NOT remove. Then, place into piston rod (21) as illustrated. Install o-ring (19), lubricating it well and replacing piston (17) onto piston rod (21). Put one drop of blue Loctite on the piston retainer screw (16). Tighten piston retainer screw until piston is locked into place. Check valve rod assembly (20) for normal spring action at this time.
6. Install piston seal (18) with lips facing downward. Carefully install o-ring (19). Expand the ring and stretch it sufficiently for installation.
7. With motor/pump block (25) still in vise, install lower seal (24) by pushing it towards its groove with a properly sized blunt rod. Then complete installation with the fingers. No tool is necessary. Do not twist the seal.
8. Pre-lubricate the piston and valve rod assembly with Coolflo™ hydraulic fluid (P/N 430-361). Install piston rod (21) into motor/pump block (25) with a gently pushing and rotating motion to work the piston rod in through the seal (24).

**NOTE: Inspect the bottom of piston rod (21) for nicks or sharp areas that could damage the piston seal during installation through the motor/pump block (25).**

9. Replace the connecting rod pin and retainer ring.
10. Install o-ring (12) on cylinder wall. Lubricate ring and inner wall. With the piston rod held firmly, the cylinder should be gently driven over the piston seal with a rubber mallet. Tightly thread the cylinder into motor/pump block (25).
11. Raise piston rod (21) to top position and thread lock ring (22) all the way up on upper threads of cylinder (23).
12. Pull valve rod assembly (20) up as far as it will travel and grasp it with vise grip pliers. Then install cylinder head (11), already assembled, over valve rod until the top threads of the valve rod pass through the top of the spool/sleeve set (5). The valve rod threads must be clean and free of oil. Place one drop of blue Loctite on threads of flex lock nut (9) and thread nut onto valve rod to full tight position (do not over-tighten) while holding valve rod below with vise grip pliers.
13. Thread cylinder head (11) down onto the cylinder (23) and then back off just enough to reassemble hydraulic fittings and motor tube (26). Tighten lock ring with spanner wrench to hold cylinder head in position.
14. The tee assembly (27) and the elbow (15) use an o-ring (28) to seal on the outer diameter (O.D.) of the motor tube (26). The O.D. of the motor tube should be free of scratches or sharp edges. The lock nuts on these fittings first should be hand tightened, then wrench tightened another half turn.
15. Install o-ring (8) onto cylinder head plug (7). Tighten.

### Reassembling the Hydraulic Motor

1. Separate spool/sleeve set (5). Place o-rings (6) onto sleeve. Lubricate o-rings with hydraulic oil. Gently push the sleeve into cylinder head (11) with the flatter side of the sleeve facing out. Use a nylon rod to tap sleeve down until it reaches its full depth. Do not use any other type of tool that might damage or leave particles or residue on the sleeve. Install the spool through the top of the cylinder head, down into the sleeve.

**IMPORTANT: Do not use Piston Lube pump packing lubricant. It is a solvent and will severely damage seals and O-Rings of the hydraulic motor.**

2. Install o-rings (2) on trip retainers (1). Install trip retainer balls (4) followed by springs (3) which, when installed, will hold spool/sleeve set (5) in proper place for assembly.
3. Install sleeve retainer (13) followed by snap ring (14) into cylinder head (11), which will hold valve sleeve in place. Install o-ring (12) in the o-ring groove of the cylinder head.

## Hydraulic Motor Cut-Away

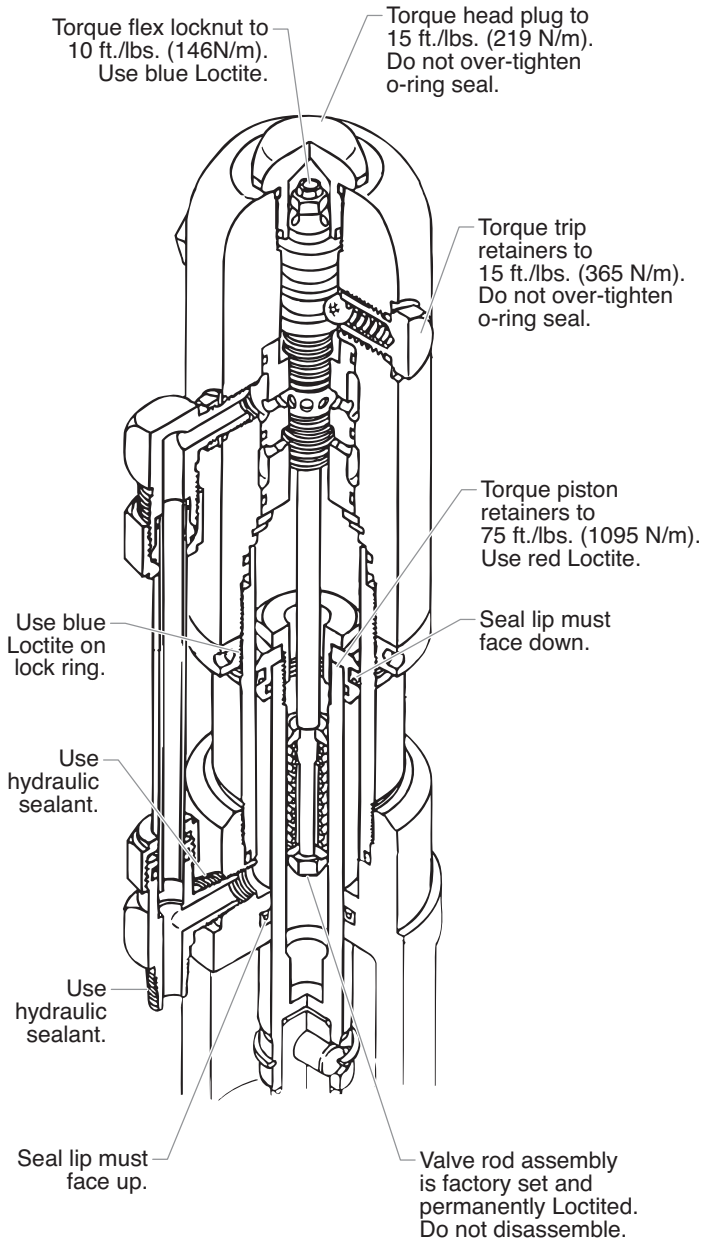

## Fluid Section

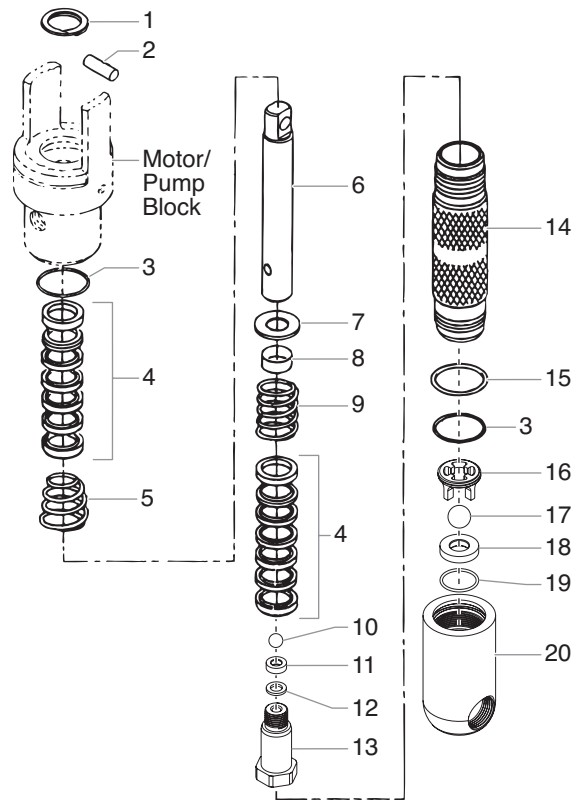

Item	Part #	Description	Quantity
1	143-019	Retainer ring.....	1
2	107-003	Connecting pin.....	1
3	106-015	O-ring, PTFE.....	2
4	106-002	Packing set, leather/UHMWPE/steel.....	2
5	106-005	Upper packing spring.....	1
6	107-029	Displacement rod.....	1
7	106-001	Spring retainer.....	1
8	106-116	Sleeve.....	1
9	106-016	Lower packing spring.....	1
10	569-021	Outlet valve ball.....	1
11	107-058	Outlet valve seat.....	1
12	107-060	Seal washer.....	1
13	107-055	Outlet valve housing.....	1
14	107-936	Pump cylinder.....	1
15	106-014	O-ring.....	1
16	107-056	Ball cage.....	1
17	138-340	Foot valve ball.....	1
18	762-137	Foot valve seat.....	1
19	762-058	Seat o-ring.....	1
20	107-057	Foot valve housing.....	1
	107-501	Fluid section service kit, major (includes items 6, 14, and fluid section service kit, minor P/N 107-051)	
	107-051	Fluid section service kit, minor (includes items 1, 3, 4, 10, 12, 15, 17, 19, and Loctite P/N 426-051)	
	107-015	Foot valve assembly (includes items 16-20)	
	107-016	Outlet valve assembly (includes items 10-13)	

## Servicing the Fluid Section

**IMPORTANT: Use of non-Titan service parts may void warranty. Ask for original parts made by Titan for best services. This pump should receive a routine servicing after approximately 1,000 hours of use. Earlier servicing is required if there is excessive leakage from the top packing or if pump strokes become faster on one stroke or the other. The use of Titan Piston Lube (P/N 314-480) is recommended as an upper packing lubricant. Do not substitute oil, water, or solvent for an upper packing lubricant.**

### Disassembling the Fluid Section

1. Remove the siphon hose assembly. Unthread the foot valve housing (20) and the pump cylinder (14) with a strap wrench.
2. Slide the retainer ring (1) up with a small screwdriver, then push the connecting pin (2) out.
3. Pull the displacement rod (6) through the lower cavity of the motor/pump block.
4. Remove the motor/pump block, PTFE o-ring (3), upper packing spring (5), and upper packing set (4).
5. Hold the displacement rod (6) in a vise by the flats at the top of the displacement rod and remove the outlet valve housing (13) with a wrench while holding the displacement rod horizontal with wooden support, if necessary. Remove the seal washer (12), outlet valve seat (13), outlet valve ball (10), lower packing set (4), lower packing spring (9), sleeve (8), and spring retainer (7).
6. Using a 1/2" extension bar attached to a 1/2" drive ratchet, insert the end of the extension bar into the square opening of the ball cage (16) inside the foot valve housing (20). Unscrew and remove the ball cage from the foot valve housing.
7. Remove the PTFE o-ring (3), foot valve ball (17), foot valve seat (18), and seat o-ring (19) from the foot valve housing (20).
8. Replace the connecting pin (2) and retainer ring (1) with new parts.
9. Remove the o-ring (15) from the pump cylinder (14)

### Reassembling the Fluid Section

**NOTE: Use PTFE tape on all threaded pipe connections.**

1. Place a new seat o-ring (19) into the groove in the bottom of the foot valve housing (20).
2. Inspect the foot valve seat (18) for wear. If one side is worn, flip the seat to the unused side. If both sides are worn, install a new seat. Place the new or flipped seat (worn side down) into the bore at the bottom of the foot valve housing (20).
3. Place a new foot valve ball (17) onto the foot valve seat (18). Using a 1/2" extension bar attached to a 1/2" drive ratchet, insert the end of the extension bar into the square opening of the ball cage (16) and screw the ball cage into the foot valve housing (20). Torque the cage to 240 in./lbs. (20 ft./lbs.).
4. Insert a new PTFE o-ring (3) into the groove of the foot valve housing (20). Lubricate the o-ring using oil or grease.
5. After soaking the leather packings in oil (preferably linseed oil), reassemble the lower packing set (4). Place the set onto the outlet valve housing (13) with the peak of the "V" packings pointing down toward the hex on the outlet valve housing.
6. Inspect the outlet valve seat (11) for wear. If one side is worn, flip the seat to the unused side. If both sides are worn, use a new seat. Insert the outlet valve ball (10), new or flipped seat (worn side away from ball), and a new seal washer (12) into the displacement rod (6).
7. Clean the threads on the outlet valve housing (13) and coat the threads with blue Loctite #242. Make sure the Loctite is only on the threads.

8. Place the lower packing spring (9) onto the outlet valve housing (13) followed by the sleeve (8) and spring retainer (7).
9. Screw the displacement rod (6) and the outlet valve housing (13) together. Tighten in a vise to 700 in./lbs. (58 ft./lbs.).
10. Insert the PTFE o-ring (3) into the upper groove of the motor/pump block.
11. Insert the upper packing set (4) into the motor/pump block with the peak of the "V" packings pointing up toward the motor.

**NOTE: The packings must be soaked in oil before installation.**

12. Place the upper packing spring (5) into the motor/pump block with the small tapered end facing up toward the motor/pump block.
13. Insert the displacement rod (6) up through the upper packings in the motor/pump block.
14. Align the holes in the displacement rod (6) and the hydraulic piston rod and insert the connecting pin (2).
15. Thread the short threads of the pump cylinder (14) into the motor/pump block and tighten with a strap wrench.
16. Place the o-ring (15) onto the top groove of the pump cylinder (14).
17. Thread the foot valve housing (20) onto the pump cylinder (14), tighten with a strap wrench and then back off to align the siphon hose.

**NOTE: It is not necessary to over-tighten the foot valve housing. O-ring seals perform sealing function without excessive tightening. Full thread engagement is sufficient. The foot valve housing may be rotated backward up to 1/2 turn from full engagement for convenient hose position.**

**For siphon hose attachment, it is critically important that the threads of the siphon hose fit snugly into the foot valve housing with the hose assembly couplings PTFE taped and sealed to prevent air leakage.**

### Fluid Section Cut-Away

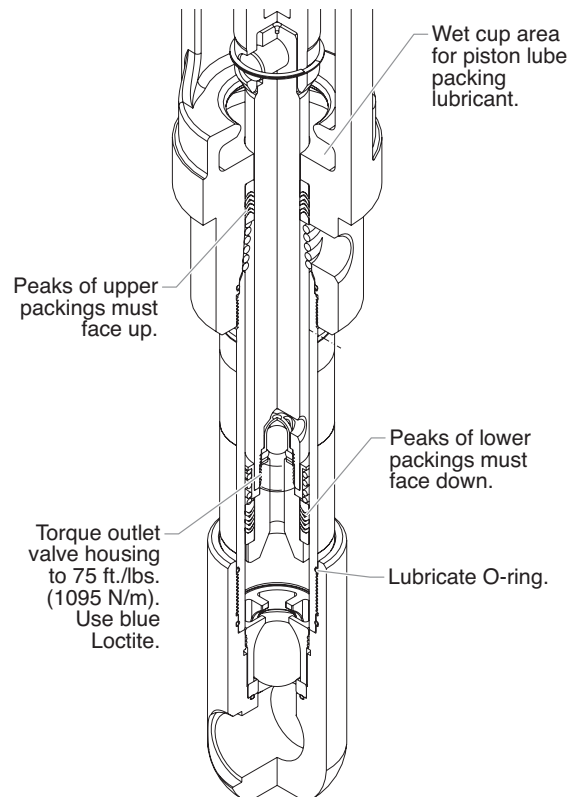

## Filter Assembly (P/N 779-098)

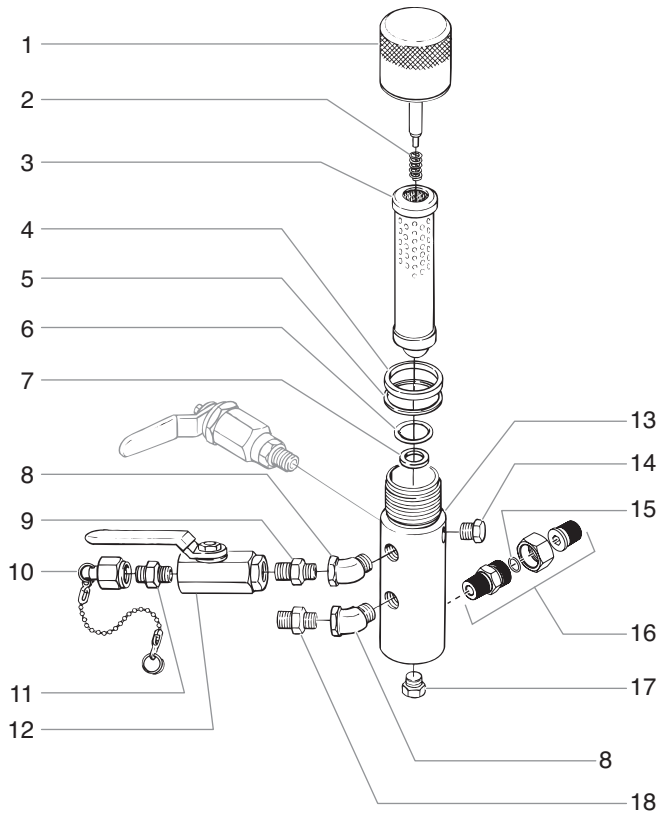

Item	Part #	Description	Quantity
1	930-937	Filter cap assembly.....	1
2	930-020	Spring.....	1
3	930-006	Filter element, 50 M, w/ball.....	1
4	920-006	Gasket, PTFE (thick).....	1
5	920-070	Gasket, PTFE (thin).....	1
6	891-193	O-ring, PTFE.....	1
7	180-909	Seat, tungsten carbide.....	1
8	193-331	Elbow.....	2
9	814-002	Hex nipple.....	1
10	730-222	Outlet cap assembly.....	1
11	227-006	Hex nipple.....	1
12	940-553	Ball valve.....	1
13	930-920	Filter body.....	1
14	227-027	Pipe plug.....	1
15	703-136	O-ring.....	1
16	703-137	Swivel fitting assembly (includes item 15)	1
17	227-033	Pipe plug.....	1
18	812-003 930-050	Hex nipple..... Filter service kit (includes items 2 and 4-6)	1

### Filter Assembly Specifications

Maximum Working Pressure .....	5000 psi (345 bar)
Filter Area.....	18 In <sup>2</sup> (116 cm <sup>2</sup> )
Outlet Ports.....	(1) 1/4" NPT(F) for bleed valve (1) 3/8" NPT(F) with 1/4 NPSM(M) hose connection (1) 3/8" NPT(F) plugged for additional gun hookup.
Wetted Parts.....	Carbon steel with electroless nickel and cadmium plating, stainless steel, tungsten carbide, PTFE

## Belt Guard Assembly

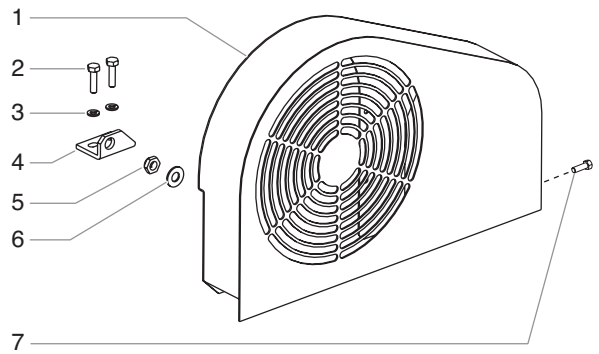

Item	Part #	Description	Quantity
1	449-216	Belt guard.....	1
2	858-636	Screw.....	2
3	858-002	Lock washer.....	2
4	449-187	Clip.....	1
5	862-411	Nut.....	1
6	862-001	Washer.....	1
7	449-1006	Screw.....	1
8	759-087	Belt guard label (not shown).....	1

## Trigger Assembly

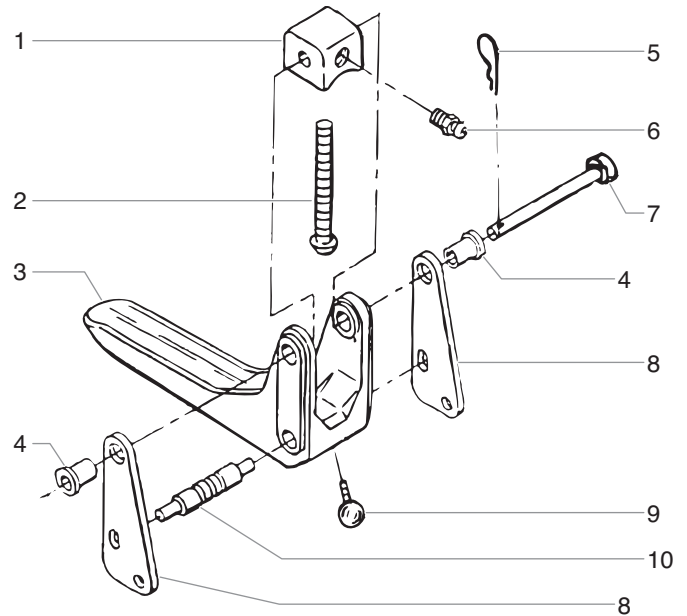

Item	Part #	Description	Quantity
1	424-219	Mounting block.....	1
2	856-744	Screw.....	1
3	424-203	Trigger.....	1
4	424-218	Flanged bearing.....	2
5	759-034	Pin.....	1
6	424-229	Grease fitting.....	1
7	759-015	Clevis pin.....	1
8	424-217	Lever plate.....	1
9	759-033	Knob.....	1
10	424-227	Spool.....	1

## SAE O-Ring Fitting Installation

Steps 1 & 2:

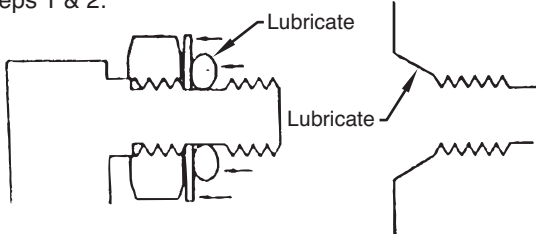

Step 3:

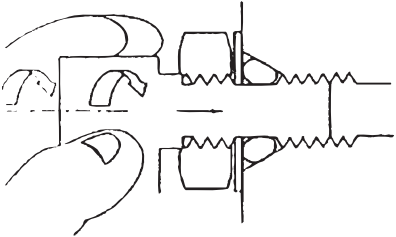

1. Pull washer and o-ring back as far as possible.
2. Lubricate o-ring and entrance port.
3. Screw fitting in until washer pushes o-ring into entrance and sits flat against port. (Do not tighten! - only do this step hand tight to compress o-ring into port!)

Step 4:

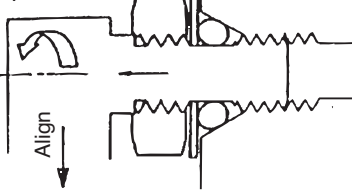

4. Back fitting out no more than one complete turn to align as required.

Step 5:

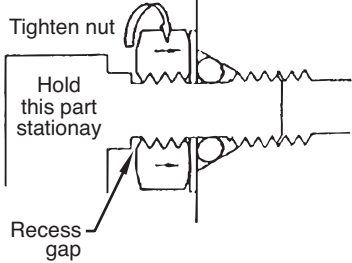

5. Torque nut wrench tight holding backup on fitting. This should expose a recess gap behind the nut which can act as an indicator that the fitting is assembled correctly. (This is a feature for a specific version of this fitting only - which screws into the cylinder head. Other fittings, as the ones which attach to the hydraulic pump, assemble the same but may not have the indicator.)

### Cautions:

Avoid screwing fitting in too far.

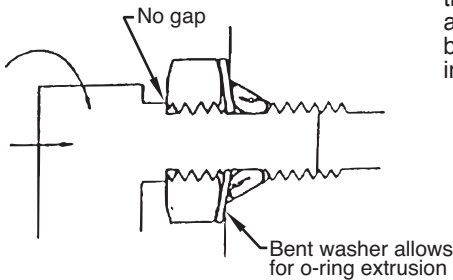

Avoid leaving fitting too far out.

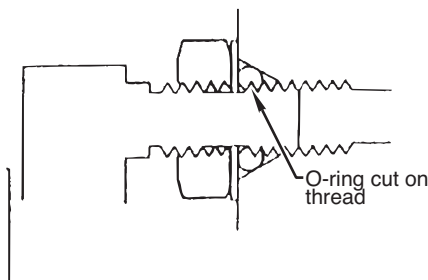

## Accessories and Service Kits

These items may be purchased separately from your local Titan distributor.

Part #	Description
103-627	Rock Catcher
550-110	S-5 G, T, and 1/4" x 50' Hose Kit
550-111	S-5 G, T, and 3/8" x 50' Hose Kit
580-050	LX-80 G, T, and 1/4" x 50' Hose Kit
101-208	Grounding Clamp
101-212	Grounding Wire, 12 Gauge x 25'
314-480	Piston Lube
430-362	Coolflo™ Hydraulic Fluid, 1 Quart
430-361	Coolflo™ Hydraulic Fluid, 1 Gallon
107-051	Fluid Section Service Kit — Minor
930-050	Filter Service Kit
611-275-1	6" Gun Extension
611-276-1	12" Gun Extension
611-277-1	18" Gun Extension
611-278-1	24" Gun Extension
930-005	Filter element, 5 mesh, w/ball
930-007	Filter element, 100 mesh, w/ball
759-145	Headlight Kit
759-120	Floating Gun Kit
759-130	Paint Hopper
759-138	Second Gun Kit (with gun)
759-076	Second Gun Kit (without gun)
759-140	Lazer Pointer
759-150	Side Striper
424-826	Bead Dispenser, 1st Gun Kit, 4-6" line width
424-816	Bead Dispenser, 2nd Gun Kit, 4-6" line width
424-836	Bead Dispenser, 2nd Gun Kit w/Hopper, 4-6" line width
424-840	Bead Dispenser, 1st Gun Kit w/Hopper, 12" line width
424-841	Bead Dispenser, 2nd Gun Kit w/Hopper, 12" line width

## Second Gun Assembly

(P/N 759-138 with gun  
P/N 759-076 without gun)

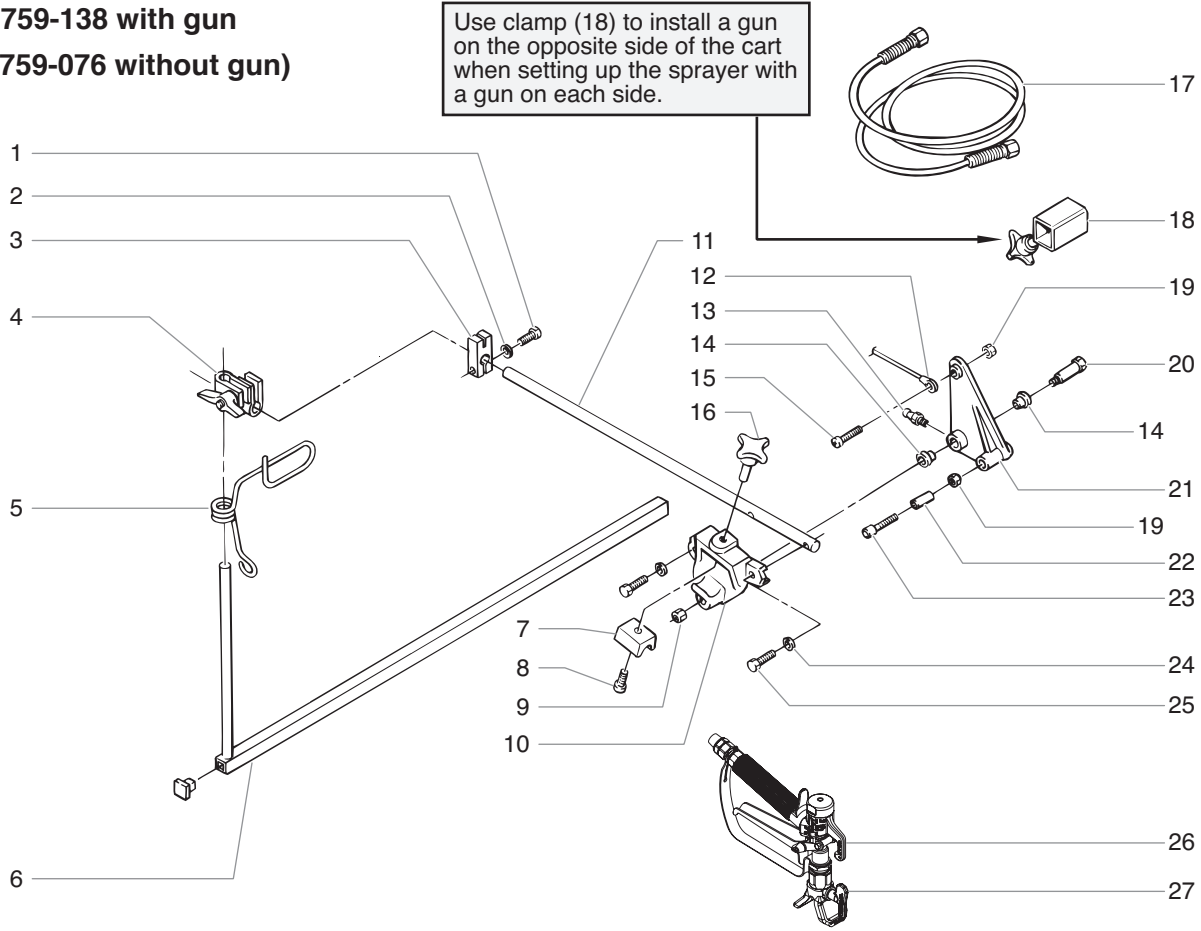

Item	Part #	Description	Quantity
1	862-436	Hex screw.....	1
2	862-002	Lock washer .....	1
3	424-226	Cable mounting clamp.....	1
4	779-083	Clamp assembly .....	1
5	424-288	Cable guide .....	1
6	756-124	Extension bar.....	1
7	779-106	Clamp .....	1
8	858-912	Screw, shoulder.....	1
9	858-601	Nut.....	1
10	424-233	Gun holder.....	1
11	424-224	Support arm.....	1
12	779-152	Gun control cable assembly .....	1
13	424-229	Grease fitting .....	1
14	424-248	Flanged bearing.....	2
15	858-637	Screw.....	1
16	756-034	Knob .....	2
17	316-533	Hose assembly, 6' .....	1
18	779-132	Clamp .....	1
19	858-603	Nut.....	2
20	860-936	Screw, shoulder.....	1
21	424-202	Actuator lever .....	1
22	424-249	Sleeve bearing.....	1
23	858-653	Screw, socket head .....	1
24	858-002	Lock washer .....	2
25	858-636	Screw, hex head.....	2
26	550-290	Airless gun, S-3 .....	1
27	661-517	Reversible tip, SC6.....	1
	665-1908	Striping tip, SC6.....	1

## Second Gun Installation

**NOTE:** The gun support beam must be removed to install the second gun and hose. The sprayer must be shut down before installation.

**!** Before installing the second gun, follow the "Pressure Relief Procedure" in the Operation section of this manual. Once you have completed this procedure, unplug the power supply cord. Failure to reduce pressure can result in serious injury.

1. Engage the first gun's trigger lock.
2. Remove the trigger cable from the block of the first gun.

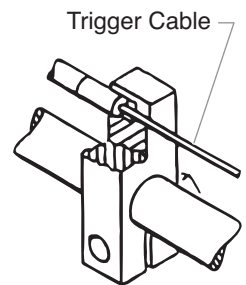

**NOTE:** The gun or guns can be installed on either side of the cart and can face either forward or backward. Refer to the "Spray Gun Positions" illustration near the back of this manual.



- Remove the plastic plug from the gun support bar. Slide the extension bar through the clamp upright and the gun support bar to the desired position. Tighten the clamp knob to secure the clamp upright and the extension bar.

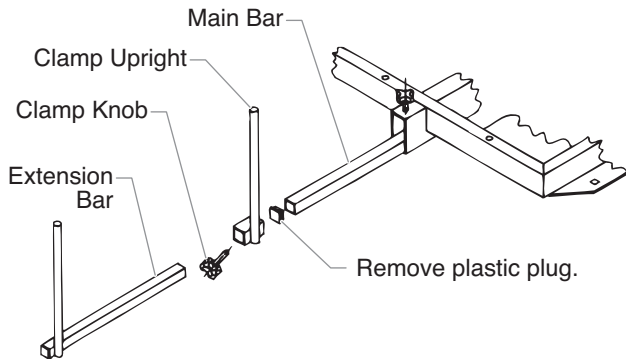

**NOTE:** The gun support bar has a clearance hole for the clamp knob to go through and tighten on the extension bar.

- Mount the gun holders as shown in the Cart Assembly exploded view drawing in this section.
- Locate the second gun outlet on the pump filter. Remove the plug and install the hex nipple and ball valve. Thread the second gun hose onto the hex nipple.

**NOTE:** Once the second gun is in position, the trigger cables can be installed on both guns. Make sure the trigger cable from the second gun is disconnected before performing the next step.

- Insert the cable bushing into the guide plate. The first gun cable and the second gun cable should be parallel.
- Insert the hooked end of the cable into the lever plate. Make sure it engages the plate.
- Reconnect the trigger cables to the guns. Connect both cables to the blocks.

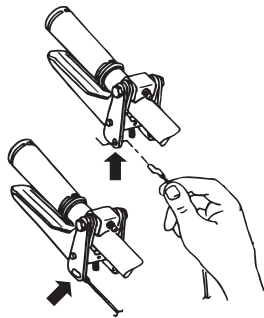

### Tension Adjustment

To increase tension, loosen the screw in the cable tension clamp block on the gun arm. Slide the block forward to increase the gap between the lever and the point where the trigger touches the gun arm.

To decrease tension, slide the block backwards. Make sure there is about 1/32" to 1/16" gap between the trigger lever and where the trigger touches the bar.

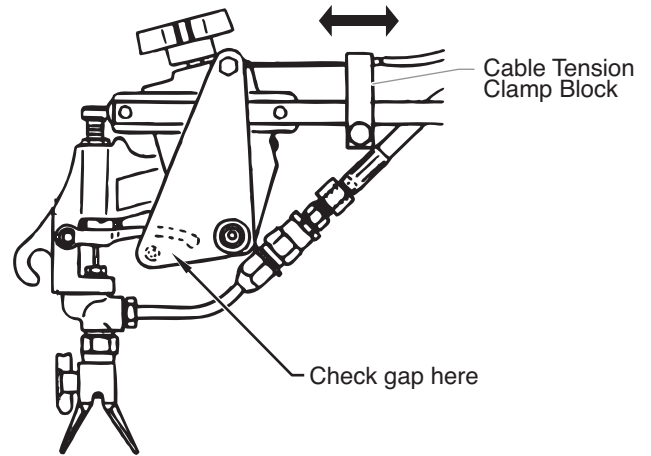

**IMPORTANT:** Always turn the trigger lock on the spray gun to the locked position before making any adjustments to the gun. Also, release the trigger cable from its block by lifting the cable up and out of the block. There will be a brief triggering of the gun while releasing the trigger cable.

### Electrical Schematic

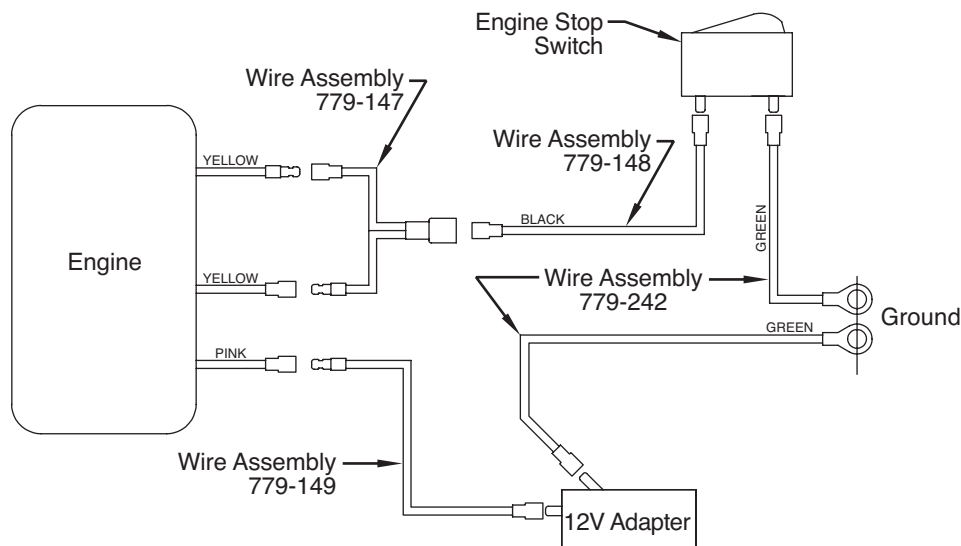

## SC-6 Striping Tip Chart

Tip Part #	Line Width	Orifice Size	Common Uses
665-1302	1"-2" (25-51 mm)	.013" (.33 mm)	Stencils & Athletic Courts — Light film (use 100 mesh filter)
665-1304	2"- 4" (51-102 mm)	.013" (.33 mm)	Stencils & Athletic Courts — Light film (use 100 mesh filter)
665-1308	4"-6" (102-152 mm)	.013" (.33 mm)	Stencils & Athletic Courts — Light film (use 100 mesh filter)
665-1502	1"-2" (25-51 mm)	.015" (.38 mm)	Stencils & Athletic Courts — Alkyd only, light film
665-1504	2"-4" (51-102 mm)	.015" (.38 mm)	Stencils & Athletic Courts — Light film
665-1508	4"-6" (102-152 mm)	.015" (.38 mm)	Stencils & Athletic Courts — Light film
665-1512	6"-8" (152-203 mm)	.015" (.38 mm)	Most traffic paints — Medium film
665-1702	1"-2" (25-51 mm)	.017" (.43 mm)	Stencils & Athletic Courts — Alkyd only, heavy film
665-1704	2"-4" (51-102 mm)	.017" (.43 mm)	Most traffic paints — Medium film
665-1708	4"-6" (102-152 mm)	.017" (.43 mm)	Most traffic paints — Light film
665-1712	6"-8" (152-203 mm)	.017" (.43 mm)	Most traffic paints — Medium film
665-1902	1"-2" (25-51 mm)	.019" (.48 mm)	Most traffic paints — Medium film
665-1904	2"-4" (51-102 mm)	.019" (.48 mm)	Most traffic paints — Heavy film
665-1908	4"-6" (102-152 mm)	.019" (.48 mm)	Most traffic paints — Medium film
665-1912	6"-8" (152-203 mm)	.019" (.48 mm)	Most traffic paints — Medium film
665-1920	10"-12" (255-305 mm)	.019" (.48 mm)	Most traffic paints — Medium film
665-2104	2"-4" (51-102 mm)	.021" (.53 mm)	Most traffic paints — Medium film
665-2108	4"-6" (102-152 mm)	.021" (.53 mm)	Most traffic paints — Heavy film
665-2112	6"-8" (152-203 mm)	.021" (.53 mm)	Most traffic paints — Light film
665-2124	12"-14" (305-357 mm)	.021" (.53 mm)	Most traffic paints — Light film
665-2128	14"-16" (357-406 mm)	.021" (.53 mm)	Most traffic paints — Light film
665-2308	4"-6" (102-152 mm)	.023" (.58 mm)	Most traffic paints — Heavy film
665-2312	6"-8" (152-203 mm)	.023" (.58 mm)	Most traffic paints — Medium film
665-2324	12"-14" (305-357 mm)	.023" (.58 mm)	Most traffic paints — Medium film
665-2328	14"-16" (357-406 mm)	.023" (.58 mm)	Most traffic paints — Medium film
665-2508	4"-6" (102-152 mm)	.025" (.64 mm)	Most traffic paints — Very heavy film
665-2512	6"-8" (152-203 mm)	.025" (.64 mm)	Most traffic paints — Heavy film
665-2708	4"-6" (102-152 mm)	.027" (.69 mm)	Most traffic paints — High speed, light film
665-2712	6"-8" (152-203 mm)	.027" (.69 mm)	Most traffic paints — Heavy film
665-2908	4"-6" (102-152 mm)	.029" (.74 mm)	Most traffic paints — High speed, medium film
665-2912	6"-8" (152-203 mm)	.029" (.74 mm)	Most traffic paints — High speed, light film
665-3108	4"-6" (102-152 mm)	.031" (.79 mm)	Most traffic paints — High speed, heavy film
665-3112	6"-8 (152-203 mm)	.031" (.79 mm)	Most traffic paints — High speed. medium film
665-3508	4"-6" (102-152 mm)	.035" (.89 mm)	Most traffic paints — High speed, heavy film
665-3512	6"-8" (152-203 mm)	.035" (.89 mm)	Most traffic paints — High speed, heavy film
665-3908	4"-6" (102-152 mm)	.039" (.99 mm)	All traffic paints — High speed, heavy film
665-3912	6"-8" (152-203 mm)	.039" (.99 mm)	All traffic paints — High speed, heavy film
665-4308	4"-6" (102-152 mm)	.043" (1.09 mm)	All traffic paints — High speed, heavy film
665-4312	6"-8" (152-203 mm)	.043" (1.09 mm)	All traffic paints — High speed, heavy film

**NOTE:** Divide the last two digits of the SC-6 striping tip part number by 2 to determine the fan width of the tip.  
**Example:** A tip with the part number 665-1308 has a .013" orifice and produces a 4" fan width.

# Spray Gun Positions

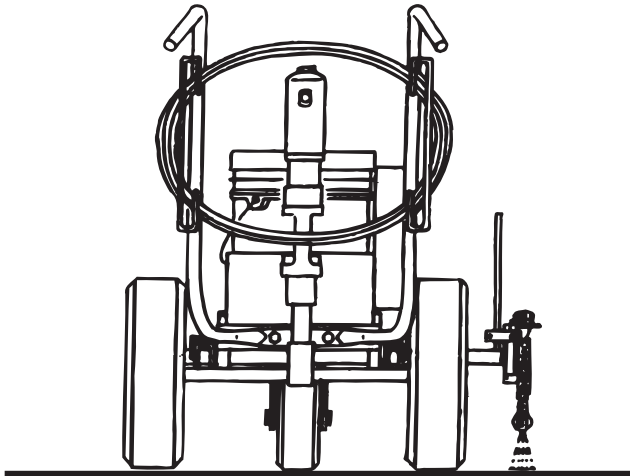

Single Line

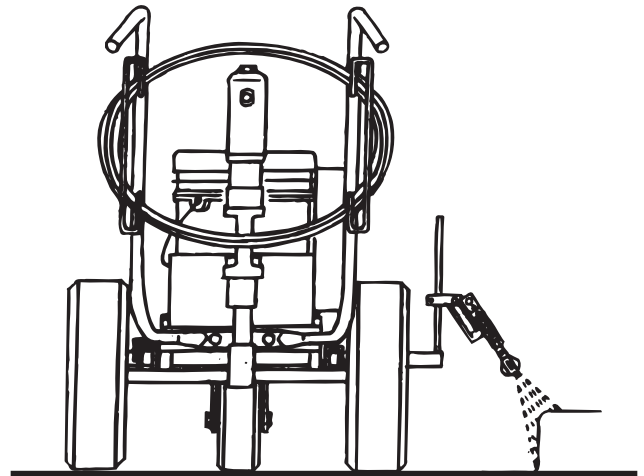

One Gun Curb

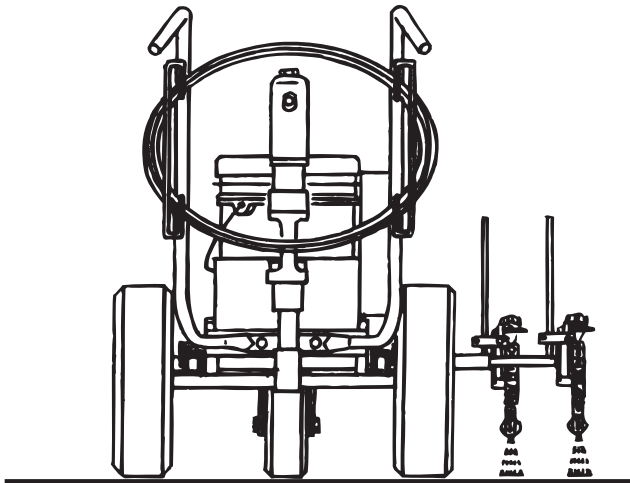

Two Lines

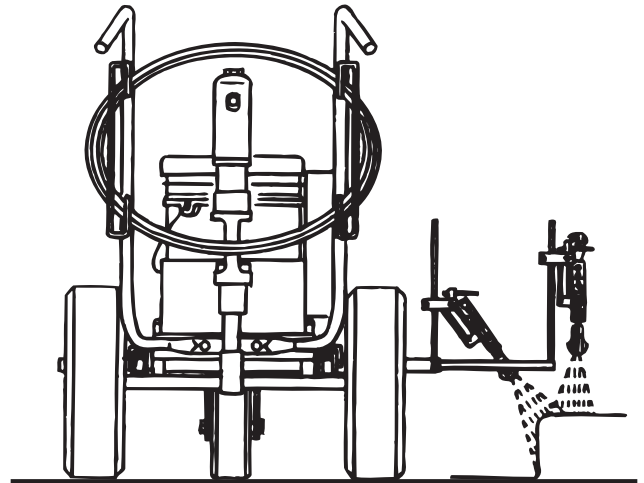

Two Gun Curb

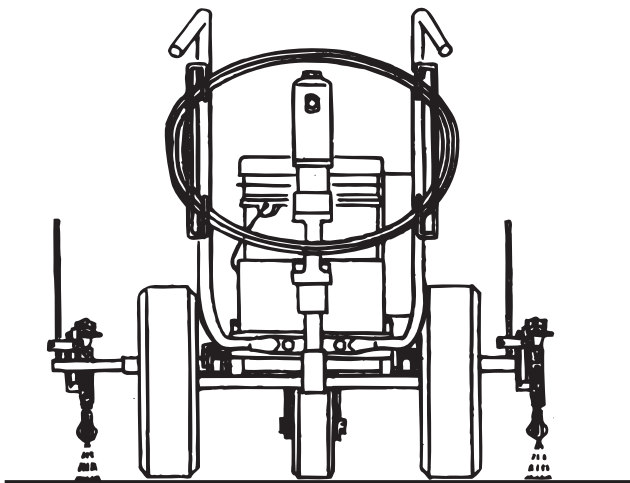

Spraying Around Obstacles

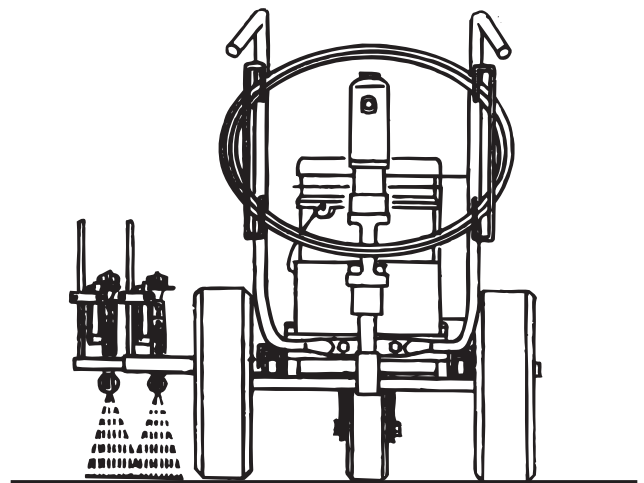

Two Lines or One Wide Line

## Warranty

Titan Tool, Inc., ("Titan") warrants that at the time of delivery to the original purchaser for use ("End User"), the equipment covered by this warranty is free from defects in material and workmanship. With the exception of any special, limited, or extended warranty published by Titan, Titan's obligation under this warranty is limited to replacing or repairing without charge those parts which, to Titan's reasonable satisfaction, are shown to be defective within twelve (12) months after sale to the End User. This warranty applies only when the unit is installed and operated in accordance with the recommendations and instructions of Titan.

This warranty does not apply in the case of damage or wear caused by abrasion, corrosion or misuse, negligence, accident, faulty installation, substitution of non-Titan component parts, or tampering with the unit in a manner to impair normal operation.

Defective parts are to be returned to an authorized Titan sales/service outlet. All transportation charges, including return to the factory, if necessary, are to be borne and prepaid by the End User. Repaired or replaced equipment will be returned to the End User transportation prepaid.

THERE IS NO OTHER EXPRESS WARRANTY. TITAN HEREBY DISCLAIMS ANY AND ALL IMPLIED WARRANTIES INCLUDING, BUT NOT LIMITED TO, THOSE OF MERCHANTABILITY AND FITNESS FOR A PARTICULAR PURPOSE, TO THE EXTENT PERMITTED BY LAW. THE DURATION OF ANY IMPLIED WARRANTIES WHICH CANNOT BE DISCLAIMED IS LIMITED TO THE TIME PERIOD SPECIFIED IN THE EXPRESS WARRANTY. IN NO CASE SHALL TITAN LIABILITY EXCEED THE AMOUNT OF THE PURCHASE PRICE. LIABILITY FOR CONSEQUENTIAL, INCIDENTAL OR SPECIAL DAMAGES UNDER ANY AND ALL WARRANTIES IS EXCLUDED TO THE EXTENT PERMITTED BY LAW.

TITAN MAKES NO WARRANTY AND DISCLAIMS ALL IMPLIED WARRANTIES OF MERCHANTABILITY AND FITNESS FOR A PARTICULAR PURPOSE WITH RESPECT TO ACCESSORIES, EQUIPMENT, MATERIALS OR COMPONENTS SOLD BUT NOT MANUFACTURED BY TITAN. THOSE ITEMS SOLD, BUT NOT MANUFACTURED BY TITAN (SUCH AS GAS ENGINES, SWITCHES, HOSES, ETC.) ARE SUBJECT TO THE WARRANTY, IF ANY, OF THEIR MANUFACTURER. TITAN WILL PROVIDE THE PURCHASER WITH REASONABLE ASSISTANCE IN MAKING ANY CLAIM FOR BREACH OF THESE WARRANTIES.

## Patents

These products are covered by one or more of the following U.S. patents:

5,947,381      5,749,528      5,660,332      5,425,506      4,611,758      4,508,268

Material Safety Data Sheets (MSDS) are available on Titan's website or by calling Customer Service.



### United States Sales & Service

Phone: 1-800-526-5362

Fax: 1-800-528-4826

1770 Fernbrook Lane  
Minneapolis, MN 55447  
[www.titantool.com](http://www.titantool.com)

### Canadian Branch

Phone: 1-800-565-8665

Fax: 1-800-856-8496

200 Trowers Road, Unit 7B  
Woodbridge, Ontario L4L 5Z8

### International

Phone: 1-201-337-1240

Fax: 1-201-405-7449

1770 Fernbrook Lane  
Minneapolis, MN 55447