

LCX 130

Line Striper

Owner's Manual

Do not use this equipment before reading this manual!



Model Number 0509040

SprayTECH[®]
THE DEPENDABLE CHOICE™

NOTE: This manual contains important warnings and instructions. Please read and retain for reference.

SprayTECH
1770 Fernbrook Lane
Minneapolis, MN 55447

Technical Assistance: 1-800-292-4637
Order Entry: 1-800-443-4500
Fax: 1-800-525-9501

www.spraytechinc.com

Table of Contents

| | |
|--|-----------|
| Safety Precautions | 2 |
| Français | 18 |
| Español | 20 |
| General Description | 4 |
| Operation | 4 |
| Setup | 4 |
| Preparing to Paint..... | 5 |
| Painting..... | 6 |
| Operating the Front Caster..... | 6 |
| Pressure Relief Procedure | 7 |
| Cleanup | 7 |
| Maintenance | 8 |
| General Repair and Service Notes..... | 8 |
| Maintaining the Engine | 8 |
| Replacing the Filter..... | 8 |
| Replacing the PRIME/SPRAY Valve..... | 8 |
| Replacing the Potentiometer | 9 |
| Replacing the sprayer ON/OFF switch..... | 9 |
| Replacing the Transducer..... | 10 |
| Replacing the Electronic Pressure Control (EPC) Board..... | 10 |
| Replacing the Slider Assembly and Slider Housing..... | 11 |
| Replacing the Gears | 12 |
| Servicing the Clutch Assembly | 12 |
| Servicing the Fluid Section | 14 |
| Troubleshooting | 17 |
| Parts Listings | 22 |
| Main Assembly..... | 22 |
| Drive Assembly | 23 |
| Cart Assembly..... | 24 |
| Fluid Section Assembly | 26 |
| Electrical Schematic | 26 |
| Filter Assembly | 27 |
| PRIME/SPRAY Assembly | 27 |
| Caster Assembly | 27 |
| Siphon Set | 28 |
| Return Hose Assembly | 28 |
| Labels | 28 |
| Accessories | 28 |
| Limited Warranty | 32 |

Safety Precautions

This manual contains information that must be read and understood before using the equipment. When you come to an area that has one of the following symbols, pay particular attention and make certain to heed the safeguard.



This symbol indicates a potential hazard that may cause serious injury or loss of life. Important safety information will follow.



This symbol indicates a potential hazard to you or to the equipment. Important information that tells how to prevent damage to the equipment or how to avoid causes of minor injuries will follow.

NOTE: Notes give important information that should be given special attention.



IMPORTANT SAFETY INSTRUCTIONS

A. SAVE THESE INSTRUCTIONS – To reduce the risks of fire or explosion, electrical shock, and the injury to persons, read and understand all instructions included in this manual. Be familiar with the controls and the proper usage of the equipment.

B. WARNING – To reduce the risk of fire or explosion:

1. Do not spray flammable or combustible materials near an open flame, pilot lights or sources of ignition such as hot objects, cigarettes, motors, electrical equipment and electrical appliances. Avoid creating sparks from connecting and disconnecting power cords.
2. For units intended for use with only water-based materials — Do not spray or clean with flammable liquids. For use with water-based liquids only.
3. For units intended for use with only water-based or mineral spirit-type materials with a minimum flash point of 21°C (69.8°F) — Do not spray or clean with liquids having a flash point of less than 21°C (69.8°F). Flash point is the temperature at which a fluid can produce enough vapor to ignite.
4. Paint or solvent flowing through the equipment is able to result in static electricity. Static electricity creates a risk of fire or explosion in the presence of paint or solvent fumes. All parts of the spray system, including the pump, hose assembly, spray gun and objects in and around the spray area shall be properly grounded to protect against static discharge and sparks. Use only conductive or grounded high-pressure airless paint sprayer hoses specified by the manufacturer.
5. Verify that all containers and collection systems are grounded to prevent static discharge.
6. For electric units — connect to a grounded outlet and use grounded extension cords. Do not use a 3 to 2 adapter.
7. Do not use a paint or solvent containing halogenated hydrocarbons. Such as chlorine, bleach mildewcide, methylene chloride and trichloroethane. They are not compatible with aluminum. Contact the coating supplier about compatibility of material with aluminum.
8. Keep spray area well ventilated. Keep a good supply of fresh air moving through the area to keep the air within the spray area free from accumulation of flammable vapors. Keep pump assembly in well ventilated area. Do not spray pump assembly.
9. Do not smoke in the spray area.
10. Do not operate light switches, engines, or similar spark producing products in the spray area.
11. Keep area clean and free of paint or solvent containers, rags, and other flammable materials.
12. Know the contents of the paint and solvents being sprayed. Read all Material Safety Data Sheets (MSDS) and container labels provided with the paints and solvents. Follow the paint and solvent manufacture's safety instructions.
13. Place pump at least 25 feet (7.62 meters) from the spray object in a well ventilated area (add more hose if necessary). Flammable vapors are often heavier than air. Floor area must be extremely well ventilated. The pump contains arcing parts that emit sparks and can ignite vapors.
14. Plastic can cause static sparks. Never hang plastic to enclose spray area. Do not use plastic drop cloths when spraying flammable material.
15. Fire extinguisher equipment shall be present and working.



C. WARNING – To reduce the risk of skin injection:

HAZARD:
Injection injury – A high pressure fluid stream produced by this equipment can pierce the skin and underlying tissues, leading to a serious injury and possible amputation. See a physician immediately. DO NOT TREAT AN INJECTION AS A SIMPLE CUT.

1. Do not aim the gun at, or spray any person or animal.
2. Keep hands and other body parts away from the discharge. For example, do not try to stop leaks with any part of the body.

3. Always use the nozzle tip guard. Do not spray without the nozzle tip guard in place.
4. Only use a nozzle tip specified by the manufacturer.
5. Use caution when cleaning and changing nozzle tips. In the case where the nozzle tip clogs while spraying, ALWAYS lock gun trigger, shut pump off, and release all pressure before servicing, cleaning tip or guard, or changing tip. Pressure will not be released by turning off the motor. The PRIME/SPRAY valve handle must be turned to PRIME to relieve the pressure. Refer to PRESSURE RELIEF PROCEDURE described in the pump manual.
6. Do not leave the unit energized or under pressure while unattended. When the unit is not in use, turn off the unit and relieve the pressure in accordance with the manufacturer's instructions.
7. High-pressure spray is able to inject toxins into the body and cause serious bodily injury. In the event that injection occurs, seek medical attention immediately.
8. Check hoses and parts for signs of damage, a leak can inject material into the skin. Inspect hose before each use. Replace any damaged hoses or parts.
9. This system is capable of producing 3300 PSI / 22.8 MPa. Only use replacement parts or accessories that are specified by the manufacturer and that are rated a minimum of 3300 PSI. This includes spray tips, nozzle guards, guns, extensions, fittings, and hose.
10. Always engage the trigger lock when not spraying. Verify the trigger lock is functioning properly.
11. Verify that all connections are secure before operating the unit.
12. Know how to stop the unit and bleed pressure quickly. Be thoroughly familiar with the controls. Pressure will not be released by turning off the motor. The PRIME/SPRAY valve handle must be turned to PRIME to relieve the pressure. Refer to PRESSURE RELIEF PROCEDURE described in the pump manual.
13. Always remove the spray tip before flushing or cleaning the system.



D. WARNING – To reduce the risk of injury:

1. Always wear appropriate gloves, eye protection, clothing and a respirator or mask when painting. Hazardous vapors – Paints, solvents, insecticides, and other materials can be harmful if inhaled or come in contact with body. Vapors can cause severe nausea, fainting or poisoning.
2. Do not operate or spray near children. Keep children away from equipment at all times.
3. Do not overreach or stand on an unstable support. Keep effective footing and balance at all times.
4. Stay alert and watch what you are doing.
5. Do not operate the unit when fatigued or under the influence of drugs or alcohol.
6. Do not kink or over-bend the hose. Airless hose can develop leaks from wear, kinking and abuse. A leak can inject material into the skin.
7. Do not expose the hose to temperatures or pressures in excess of those specified by manufacturer.
8. Do not use the hose as a strength member to pull or lift the equipment.
9. Use lowest possible pressure to flush equipment.
10. Follow all appropriate local, state and national codes governing ventilation, fire prevention and operation.
11. The United States Government Safety Standards have been adopted under the Occupational Safety and Health Act (OSHA). These standards, particularly part 1910 of the General Standards and part 1926 of the Construction Standards should be consulted.

12. Before each use, check all hoses for cuts, leaks, abrasion or bulging of cover. Check for damage or movement of couplings. Immediately replace hose if any of those conditions exist. Never repair a paint hose. Replace with a conductive high-pressure hose.
13. Do not spray outdoors on windy days.
14. Always unplug cord from outlet before working on equipment.



Do not lift by cart handle when loading or unloading.

Gasoline Engine Safety



The engine exhaust from this unit contains chemicals known to the State of California to cause cancer, birth defects, or other reproductive harm.

1. Gas engines are designed to give safe and dependable service if operated according to instructions. Read and understand the engine Owner's Manual before operating the engine. Failure to do so could result in personal injury or equipment damage.
2. To prevent fire hazards and to provide adequate ventilation, keep the engine at least 1 meter (3 feet) away from buildings and other equipment during operation. Do not place flammable objects close to the engine.
3. Children and pets must be kept away from the area of operation due to a possibility of burns from hot engine components or injury from any equipment the engine may be used to operate.
4. Know how to stop the engine quickly, and understand the operation of all controls. Never permit anyone to operate the engine without proper instructions.
5. Gasoline is extremely flammable and is explosive under certain conditions.
6. Refuel in a well-ventilated area with the engine stopped. Do not smoke or allow flames or sparks in the refueling area or where gasoline is stored.
7. Do not overfill the fuel tank. After refueling, make sure the tank cap is closed properly and securely.
8. Be careful not to spill fuel when refueling. Fuel vapor or spilled fuel may ignite. If any fuel is spilled, make sure the area is dry before starting the engine.
9. Never run the engine in an enclosed or confined area. Exhaust contains poisonous carbon monoxide gas; exposure may cause loss of consciousness and may lead to death.
10. The muffler becomes very hot during operation and remains hot for a while after stopping the engine. Be careful not to touch the muffler while it is hot. To avoid severe burns or fire hazards, let the engine cool before transporting it or storing it indoors.
11. Never ship/transport unit with gasoline in the tank.

Specifications

| | |
|--------------------------------|---------------------|
| Gallons per minute (GPM) | 1.30 (4.92 LPM) |
| Maximum tip size | one gun = 0.035" |
| | two guns = 0.025" |
| Maximum pressure | 3300 PSI (22.8 MPa) |
| Power | 6.0 HP gas engine |
| Weight | 272 lbs. (123.4 kg) |

General Description

This airless line striper is a precision power tool used to spray many types of material for many types of applications including parking lots, curbs, and athletic fields. Read and follow this instruction manual carefully for proper operating instructions, maintenance, and safety information.

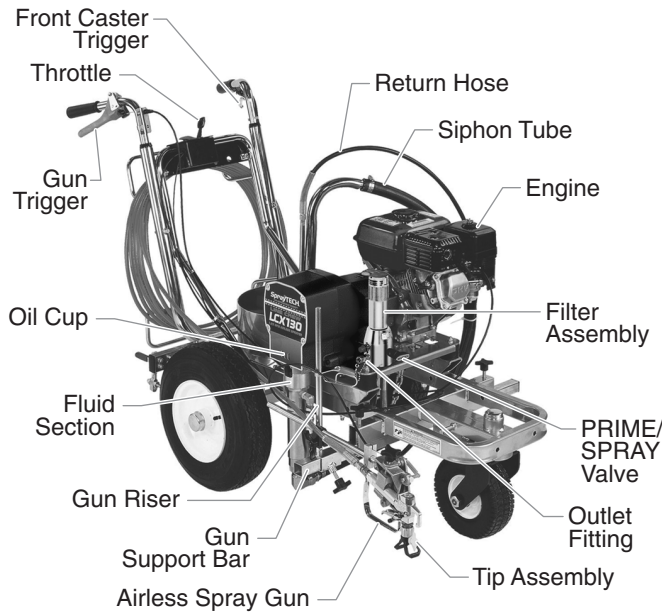

Operation



This equipment produces a fluid stream at extremely high pressure. Read and understand the warnings in the Safety Precautions section at the front of this manual before operating this equipment.

Setup

Perform the following procedure before starting the engine of a gas-powered sprayer.

1. Ensure that the siphon tube and the return hose are attached and secure.
2. Using a wrench, attach a minimum of 50' of 1/4" nylon airless spray hose to the outlet fitting on the filter assembly of the sprayer. Tighten securely.
3. Install the gun support bar.

NOTE: The spray gun, hose, and cables are mounted to the gun support bar at the factory.

- a. Loosen the support bar clamps on each side of the cart.
- b. Slide the gun support bar through the cart.
- c. Tighten the support bar clamps to secure the gun support bar in position.

NOTE: The gun support bar and the spray gun(s) can be mounted on either side of the sprayer.



Always follow the Pressure Relief Procedure when shutting the sprayer down for any purpose, including servicing or adjusting any part of the spray system, changing or cleaning spray tips, or preparing for cleanup.

4. Position the first spray gun.
 - a. Disengage the trigger cable from the tensioning clamp.



Always disengage the trigger cable from the tensioning clamp before making any adjustments to the spray gun position.

- b. Loosen the support bar clamps and slide the gun support bar to the desired horizontal position.
- c. Loosen the gun riser clamp and slide the spray gun to the desired vertical position.

NOTE: The height of the spray gun affects the width of the spray pattern (i.e., the lower the gun, the smaller the line width). Tip size also affects line width.

4. Install the second gun assembly, if desired. Refer to the installation instructions that come with the second gun assembly accessory.
5. Set the trigger selector for proper spray gun operation. The right handlebar triggers the gun or guns. The selector on the trigger must be set for the first gun, both guns, or the second gun.



Always turn the trigger lock on the spray gun to the locked position before making any adjustments to the trigger selector. Also, release the trigger cable from its block by lifting the cable up and out of the block. There will be a brief triggering of the gun while releasing the trigger cable.

- a. **First Gun** — The first gun position is with the selector in the left position. Push the lever toward the inside of the frame until the pin engages the left plate.

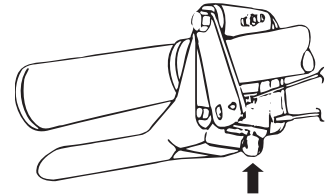

- b. **Both Guns** — The dual gun position is with the selector in the center position. Push the lever toward the center position until the pin engages both plates. The pin must engage both plates.

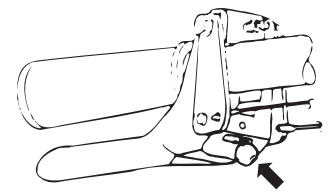

- c. **Second Gun** — The second gun position is with the selector in the right position. Push the lever away from the inside of the frame until the pin engages the right plate.

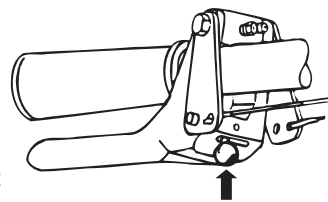

4. Turn the pressure control knob fully counterclockwise to its lowest pressure setting.
5. Make sure the sprayer ON/OFF switch is in the OFF position.
6. Fill the fluid section oil cup with approximately one tablespoon of separating oil (P/N 0279920).



Never operate unit for more than ten seconds without fluid. Operating this unit without fluid will cause unnecessary wear to the packings.

7. Check the engine oil level. The gasoline engine oil level is determined by the manufacturer. Refer to the engine manufacturer's service manual (supplied).
8. Close the fuel shut-off lever and fill the gas tank with gasoline. Use only high quality, unleaded gasoline.

Adjusting the Trigger Tension

Use the following procedure to adjust the spring tension of the trigger lever on the gun holder assembly. The trigger lever pulls and releases the spray gun trigger when operated from the trigger on the cart. The proper tension ensures that the gun will shut off when the gun trigger is released. To ensure proper tension, there should be approximately a 1/32" to 1/16" gap between the trigger lever and the spray gun trigger.

CAUTION

Always keep the trigger lock on the spray gun in the locked position while making adjustments to the system.

1. Using a 5/32" hex wrench, loosen the set screw on the cable block.
2. Move the cable block in the appropriate direction to create a gap of 1/32" to 1/16" between the trigger lever and spray gun trigger.
 - a. Slide the cable block toward the gun to increase the gap between the trigger lever and spray gun trigger.
 - b. Slide the cable block away from the gun to decrease the gap between the trigger lever and spray gun trigger.

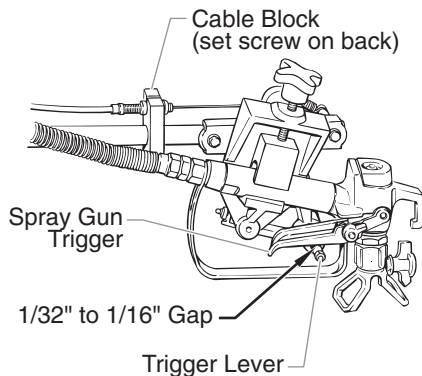

3. Tighten the set screw securely.

Preparing a New Sprayer

If this unit is new, it is shipped with test fluid in the fluid section to prevent corrosion during shipment and storage. This fluid must be thoroughly cleaned out of the system with mineral spirits before you begin spraying.

CAUTION

Always keep the trigger lock on the spray gun in the locked position while preparing the system.

1. Place the siphon tube into a container of mineral spirits that has a flash point of 60°C (140°F) or above.
2. Place the return hose into a metal waste container.
3. Turn the pressure control knob fully counterclockwise to its lowest pressure setting.
4. Move the PRIME/SPRAY valve to the PRIME position.
5. Move the engine ON/OFF switch to the ON position.
6. Start the engine:
 - a. Open the fuel valve lever.
 - b. Move the throttle lever away from the gas tank.
 - c. Close the engine choke lever.
 - d. Holding the frame with one hand, pull the starter rope rapidly and firmly. Continue to hold the rope as you let it return. Pull and return the rope until the engine starts.

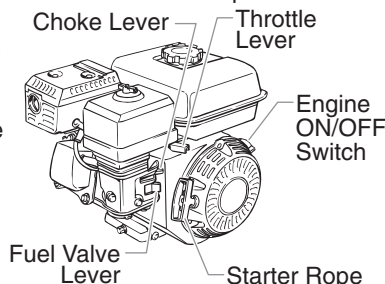

7. Turn on the sprayer by moving the sprayer ON/OFF switch to the ON position.
8. Slowly turn the pressure control knob clockwise to increase the pressure until fluid starts to come out of the return hose. Use only enough pressure to keep the fluid coming out.
9. Allow the sprayer to run for 15–30 seconds to flush the test fluid out through the return hose and into the waste container.
10. Turn the pressure control knob fully counterclockwise to its lowest setting.
11. Turn off the sprayer by moving the sprayer ON/OFF switch to the OFF position.

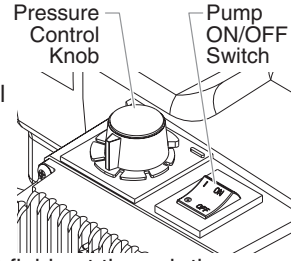

Preparing to Paint

Before painting, it is important to make sure that the fluid in the system is compatible with the paint that is going to be used.

NOTE: Incompatible fluids and paint may cause the valves to become stuck closed, which would require disassembly and cleaning of the sprayer's fluid section.

CAUTION

Always keep the trigger lock on the spray gun in the locked position while preparing the system.

1. Place the siphon tube into a container of the appropriate solvent for the material being sprayed (refer to recommendations of the material manufacturer). An example of the appropriate solvent is water for latex paint.
2. Place the return hose into a metal waste container.
3. Turn the pressure control knob fully counterclockwise to its lowest pressure setting.
4. Move the PRIME/SPRAY valve to the PRIME position.

NOTE: Hold the return hose in the waste container when moving the PRIME/SPRAY valve to PRIME in case the sprayer is pressurized.

5. Move the engine ON/OFF switch to the ON position.
6. Start the engine:
 - a. Open the fuel valve lever.
 - b. Move the throttle lever away from the gas tank.
 - c. Close the engine choke lever.
 - d. Holding the frame with one hand, pull the starter rope rapidly and firmly. Continue to hold the rope as you let it return. Pull and return the rope until the engine starts.
7. Turn on the sprayer by moving the sprayer ON/OFF switch to the ON position.
8. Slowly turn the pressure control knob clockwise to increase the pressure until fluid starts to come out of the return hose. Use only enough pressure to keep the fluid coming out.
9. Allow the sprayer to run for 15–30 seconds to flush the old solvent out through the return hose and into the metal waste container.
10. Turn the pressure control knob fully counterclockwise to its lowest setting.
11. Turn off the sprayer by moving the sprayer ON/OFF switch to the OFF position.

NOTE: Make sure that the spray gun does not have a tip or tip guard installed.

12. Move the PRIME/SPRAY valve to the SPRAY position.
13. Turn on the sprayer.
14. Turn the pressure control knob slowly clockwise to increase pressure.

- Unlock the gun by turning the gun trigger lock to the unlocked position.

⚠️WARNING

Ground the gun by holding it against the edge of the metal container while flushing. Failure to do so may lead to a static electric discharge, which may cause a fire.

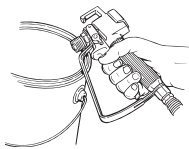

- Trigger the gun into the metal waste container until the old solvent is gone and fresh solvent is coming out of the gun.
- Lock the gun by turning the gun trigger lock to the locked position.
- Set down the gun and increase the pressure by turning the pressure control knob slowly clockwise to its highest setting.
- Check the entire system for leaks. If leaks occur, turn the sprayer off and follow the "Pressure Relief Procedure" in this manual before tightening any fittings or hoses.
- Follow the "Pressure Relief Procedure" in this manual before changing from solvent to paint.

⚠️WARNING

Be sure to follow the pressure relief procedure when shutting the unit down for any purpose, including servicing or adjusting any part of the spray system, changing or cleaning spray tips, or preparing for cleanup.

Painting

- Place the siphon tube into a container of paint.
- Place the return hose into a metal waste container.
- Turn the pressure control knob fully counterclockwise to its lowest pressure setting.
- Move the PRIME/SPRAY valve to the PRIME position.
- Move the engine ON/OFF switch to the ON position.
- Start the engine:
 - Open the fuel valve lever.
 - Move the throttle lever away from the gas tank.
 - Close the engine choke lever.
 - Holding the frame with one hand, pull the starter rope rapidly and firmly. Continue to hold the rope as you let it return. Pull and return the rope until the engine starts.
- Turn on the sprayer by moving the sprayer ON/OFF switch to the ON position.
- Slowly turn the pressure control knob clockwise to increase the pressure until fluid starts to come out of the return hose. Use only enough pressure to keep the fluid coming out.
- Allow the sprayer to run until paint is coming through the return hose into the metal waste container.
- Turn the pressure control knob fully counterclockwise to its lowest setting.
- Turn off the sprayer by moving the sprayer ON/OFF switch to the OFF position.
- Remove the return hose from the waste container and place it in its operating position above the container of paint.
- Move the PRIME/SPRAY valve to the SPRAY position.
- Turn on the sprayer.
- Turn the pressure control knob slowly clockwise to increase pressure.

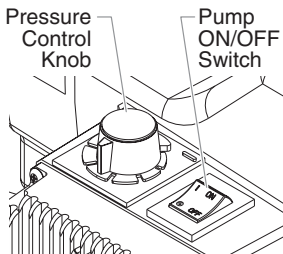
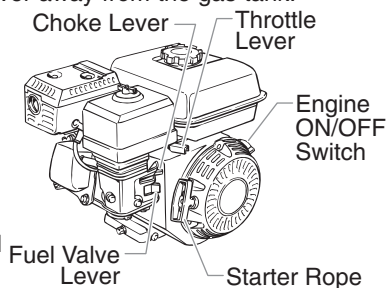

- Unlock the gun by turning the gun trigger lock to the unlocked position.

⚠️WARNING

Ground the gun by holding it against the edge of the metal container while flushing. Failure to do so may lead to a static electric discharge, which may cause a fire.

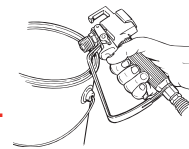

- Trigger the gun into the metal waste container until all air and solvent is flushed from the spray hose and paint is flowing freely from the gun.
- Lock the gun by turning the gun trigger lock to the locked position.
- Turn the pressure control knob fully counterclockwise to its lowest setting.
- Turn off the sprayer.
- Attach tip guard and tip to the gun as instructed by the tip guard or tip manuals.

⚠️WARNING

POSSIBLE INJECTION HAZARD. Do not spray without the tip guard in place. Never trigger the gun unless the tip is in either the spray or the unclog position. Always engage the gun trigger lock before removing, replacing or cleaning tip.

- Turn on the sprayer.
- Increase the pressure by turning the pressure control knob slowly clockwise. Test the spray pattern and line position on a long piece of roofing felt or cardboard.
 - Adjust the pressure control knob until the spray from the gun is completely atomized. Try to keep the pressure control knob at the lowest setting that maintains good atomization.

NOTE: Turning the pressure up higher than needed to atomize the paint will cause premature tip wear and additional overspray.

- Check for proper line width and position. If adjustment to the position of the spray gun is required, refer to the "Setup" procedure earlier in this section.
- Make sure that the spray gun shuts off completely when the gun trigger is released. If adjustment to the trigger tension is required, refer to the "Adjusting the Trigger Tension" procedure earlier in this section.

Operating the Front Caster

The front caster on the cart is designed to track the sprayer in either a straight line or allow free motion. Standing behind the sprayer, the trigger on the left handle of the cart controls the operation of the front caster.

- To lock the front caster in the straight line position, squeeze then release the caster trigger and move the sprayer forward.
- To allow free motion of the front caster, squeeze and hold the caster trigger.

Pressure Relief Procedure

WARNING

Be sure to follow the pressure relief procedure when shutting the unit down for any purpose, including servicing or adjusting any part of the spray system, changing or cleaning spray tips, or preparing for cleanup.

1. Lock the gun by turning the gun trigger lock to the locked position.
2. Turn off the sprayer by moving the sprayer ON/OFF switch to the OFF position.
3. Turn off the engine by moving the engine ON/OFF switch to the OFF position.
4. Turn the pressure control knob counterclockwise to its lowest setting.
5. Unlock the gun by turning the gun trigger lock to the unlocked position.
4. Hold the metal part of the gun firmly to the side of a metal container to ground the gun and avoid a build up of static electricity.
5. Trigger the gun to remove any pressure that may still be in the hose.
6. Lock the gun by turning the gun trigger lock to the locked position.
7. Move the PRIME/SPRAY valve to the PRIME position.

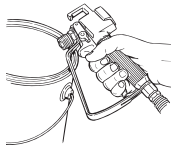

Cleanup

WARNING

Special cleanup instructions for use with flammable solvents:

- Always flush spray gun preferably outside and at least one hose length from spray pump.
- If collecting flushed solvents in a one gallon metal container, place it into an empty five gallon container, then flush solvents.
- Area must be free of flammable vapors.
- Follow all cleanup instructions.

CAUTION

The sprayer, hose, and gun should be cleaned thoroughly after daily use. Failure to do so permits material to build up, seriously affecting the performance of the unit.

WARNING

Always spray at minimum pressure with the gun nozzle tip removed when using mineral spirits or any other solvent to clean the sprayer, hose, or gun. Static electricity buildup may result in a fire or explosion in the presence of flammable vapors.

1. Follow the "Pressure Relief Procedure" found in the Operation section of this manual.
2. Remove the gun tip and tip guard and clean with a brush using the appropriate solvent.
3. Place the siphon tube into a container of the appropriate solvent (refer to recommendations of the material manufacturer). An example of the appropriate solvent is water for latex paint.
4. Place the return hose into a metal waste container.
5. Move the PRIME/SPRAY valve to its PRIME position.

NOTE: Hold the return hose in the waste container when moving the PRIME/SPRAY valve to PRIME in case the sprayer is pressurized.

6. Move the engine ON/OFF switch to the ON position and start the engine.
7. Turn on the sprayer by moving the sprayer ON/OFF switch to the ON position.
8. Slowly turn the pressure control knob clockwise to increase the pressure until fluid starts to come out of the return hose.
9. Allow the solvent to circulate through the sprayer and flush the paint out of the return hose into the metal waste container.
10. Turn the pressure control knob fully counterclockwise to its lowest setting.
11. Turn off the sprayer by moving the ON/OFF switch to the OFF position.
12. Move the PRIME/SPRAY valve to its SPRAY position.
13. Turn on the sprayer.
14. Turn the pressure control knob slowly clockwise to increase pressure.

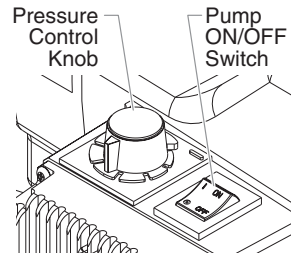

WARNING

Ground the gun by holding it against the edge of the metal container while flushing. Failure to do so may lead to a static electric discharge, which may cause a fire.

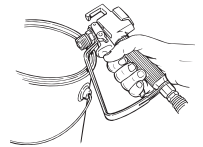

15. Trigger the gun into the metal waste container until the paint is flushed out of the hose and solvent is coming out of the gun.
16. Continue to trigger the spray gun into the waste container until the solvent coming out of the gun is clean.

NOTE: For long-term or cold weather storage, pump mineral sprits through the entire system.

17. Follow the "Pressure Relief Procedure" found in the Operation section of this manual.
18. Store the sprayer in a clean, dry area.

CAUTION

Do not store the sprayer under pressure.

Cleaning the Spray Tip

1. Flush the gun with solvent immediately after the work is completed.
2. Oil the sliding pins to prevent them from seizing up.

Should the spray tip become clogged, reverse the spray tip with the lever and pull the trigger. Once the obstruction comes out of the spray tip, release the trigger, reverse the spray tip back to the spray pattern setting, and resume spraying.



WARNING

Do not attempt to clean the tip with your finger.

Do not use a needle or other sharp pointed instrument to clean the tip. The hard tungsten carbide is brittle and can be chipped.

Maintenance

⚠ WARNING

Before proceeding, follow the Pressure Relief Procedure outlined previously in this manual. Additionally, follow all other warnings to reduce the risk of an injection injury, injury from moving parts, or electric shock.

NOTE: All engine work should be performed by an authorized service center.

General Repair and Service Notes

The following tools are needed when repairing this sprayer:

| | |
|------------------------|----------------------|
| Phillips screwdriver | 3/8" hex wrench |
| needle-nose pliers | 5/16" hex wrench |
| adjustable wrench | 1/4" hex wrench |
| rubber mallet | 3/16" hex wrench |
| flat-blade screwdriver | 1/8" hex wrench |
| 1/2" open-end wrench | 7/8" open-end wrench |

1. Before repairing any part of the sprayer, read the instructions carefully, including all warnings.

⚠ CAUTION

Never pull on a wire to disconnect it. Pulling on a wire could loosen the connector from the wire.

2. Test your repair before regular operation of the sprayer to be sure that the problem is corrected. If the sprayer does not operate properly, review the repair procedure to determine if everything was done correctly. Refer to the Troubleshooting section to help identify other possible problems.
3. Make certain that the service area is well ventilated in case solvents are used during cleaning. Always wear protective eyewear while servicing. Additional protective equipment may be required depending on the type of cleaning solvent. Always contact the supplier of solvents for recommendations.
4. If you have any further questions concerning your SprayTECH airless sprayer, call SprayTECH:

Technical Service.....1-800-292-4637
Fax1-800-525-9501

Maintaining the Engine

⚠ WARNING

When transporting a sprayer with a gas engine, make sure the fuel is shut off.

NOTE: For detailed engine specifications and maintenance, refer to the separate engine manual supplied with this sprayer.

Important Facts Concerning this Sprayer

This gas-powered sprayer contains a clutch that engages when the sprayer is pumping. The sprayer's pressure control system engages and disengages the clutch to control pressure. To prevent unnecessary wear to the clutch, it is advisable to adjust the engine speed and pressure setting to limit the amount of times the clutch engages and disengages. To reduce clutch wear, refer to the following examples.

Example:

Operating one gun with a .019 tip — reduce the engine speed by adjusting the throttle to a low or medium setting and increase pressure only until the heavy ends of the spray pattern have been eliminated.

Example:

Operating one gun with .023 tip — increase engine speed to a high setting and increase pressure until the heavy ends of the spray pattern have been eliminated.

Example:

Spraying light-bodied materials at low pressure — to reduce surging at the gun and to decrease clutch wear, reduce the engine speed to idle and reduce pressure until the desired spray pattern is achieved.

Routine Engine Maintenance

Daily

- Check and fill the gas tank.
- After the first 20 hours of operation, drain the oil and refill with clean oil. Check the engine oil level and fill as necessary.

Weekly

- Remove the cover of the air filter and clean the element. Replace the element if necessary. If operating in an unusually dusty environment, check the filter daily and replace if necessary. (Replacement elements can be purchased from your local SprayTECH dealer.)
- After each 50 hours of operation: Change the engine oil.

Spark Plug

- Use only a (NKG) BP6ES plug.
- Gap the plug 0.025" – 0.030" (0.7 – 0.8 mm).
- Make sure to use a spark plug wrench when installing and removing the plug.

Replacing the Filter

1. Loosen and remove the filter body by hand.
2. Remove the filter and filter support spring from the filter housing.
3. Remove the filter support spring and adapter from inside the filter.
4. Inspect the filter. Based on inspection, clean or replace the filter.
5. Inspect the filter housing o-ring. Based on inspection, clean or replace the o-ring.
6. Slide the new or cleaned filter over the adapter and filter support spring. Place the filter and filter support spring into the center of the filter housing.
7. Clean the inside of the filter body.
8. Slide the filter body over the filter and thread it into the filter housing until secure. Make sure the filter spring is in position on top of the filter.

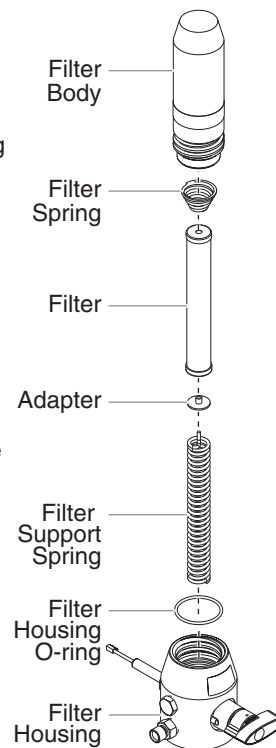

NOTE: The filter body should be hand-tightened, but make sure it is seated fully into the filter housing.

Replacing the PRIME/SPRAY Valve

Perform the following procedure using PRIME/SPRAY valve replacement kit P/N 0507690.

1. Drive the groove pin out of the valve handle.
2. Remove the valve handle and the cam base.
3. Using a wrench, loosen and remove the valve housing assembly.

4. Make sure the gasket is in place and thread the new valve housing assembly into the filter housing. Tighten securely with a wrench.
5. Place the cam base over the valve housing assembly. Lubricate the cam base with grease and line up the cam with the filter block using the dowel pin.
6. Line up the hole on the valve stem with the hole in the valve handle.
7. Insert the groove pin into the valve handle and through the valve stem to secure the valve handle in position.

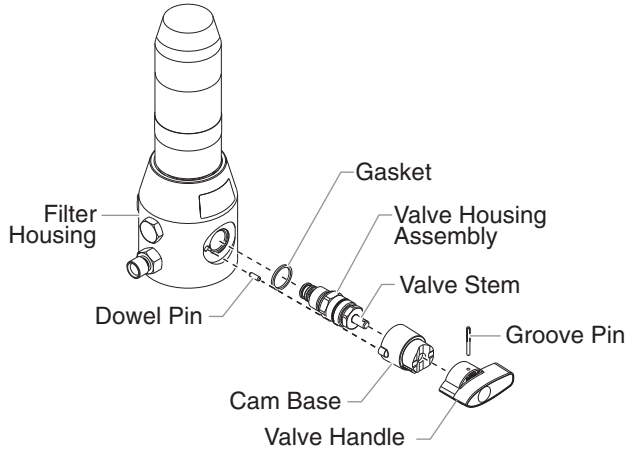

Replacing the Potentiometer

WARNING

Electrostatic discharge (ESD) potential could cause damage to electronic pressure control. Use SprayTECH ESD wrist strap P/N 0507958 or equivalent when working on electronic pressure control.

1. Perform the Pressure Relief Procedure.
2. Pry off the pressure control knob cap to expose the knob tension nut.
3. Turn the pressure control knob fully counterclockwise to the minimum pressure setting.
4. Using a 5/16" socket, loosen the tension nut in the center of the knob. Remove the knob.
5. Using a Phillips screwdriver, remove the four screws that secure the electronic pressure control (EPC) assembly to the EPC housing. Carefully remove the EPC assembly from the housing. Gently move the assembly away from the sprayer and allow the assembly to hang from the housing.

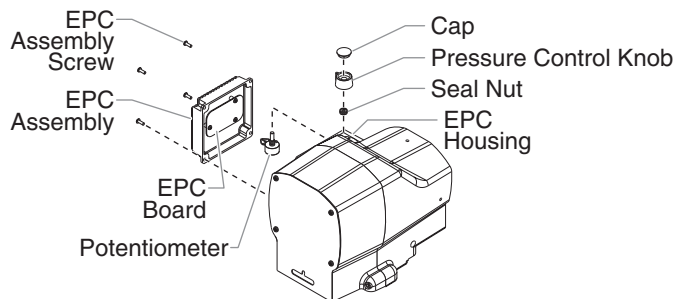

6. Hold the potentiometer inside the EPC housing while using a 1/2" thin wall socket to remove the seal nut that secures the potentiometer to the mounting plate. Remove the potentiometer from the EPC housing.
7. Carefully remove the potentiometer wires from their connection point on the EPC board.
8. Insert the stem of the new potentiometer through the hole in the mounting plate from inside the EPC housing. Position the protruding tab on the potentiometer face into the hole on the underside of the mounting plate (the wires will face the open side of the EPC housing).

9. Thread the seal nut onto the threaded portion of the stem and tighten using a 1/2" thin wall socket.

CAUTION

Do not over-tighten the seal nut.

10. Turn the potentiometer stem fully counterclockwise.
11. Place the pressure control knob on the potentiometer stem with the indicator tab resting at the "minimum pressure" tab on the mounting plate.
12. Tighten the knob tension nut using a 5/16" socket.

CAUTION

Do not over-tighten the knob tension nut. Over-tightening will damage the potentiometer.

13. Connect the potentiometer wires to the EPC board. The protruding tab on the EPC board connector will mate with the slot on the potentiometer wires connector. The connector on the end of the potentiometer wires and the connector on the EPC board will mate only one way. Do not force the connectors together.
14. Carefully place the EPC assembly over the EPC housing taking care not to pinch any wires.
15. Install the four screws that secure the EPC assembly to the EPC housing. Tighten securely.

Replacing the Sprayer ON/OFF Switch

WARNING

Electrostatic discharge (ESD) potential could cause damage to electronic pressure control. Use SprayTECH ESD wrist strap P/N 0507958 or equivalent when working on electronic pressure control.

1. Perform the Pressure Relief Procedure.
2. Using a Phillips screwdriver, remove the four screws that secure the electronic pressure control (EPC) assembly to the EPC housing. Carefully remove the EPC assembly from the housing. Gently move the assembly away from the sprayer and allow the assembly to hang from the housing.
3. Locate the bottom of the sprayer ON/OFF switch inside the EPC housing.

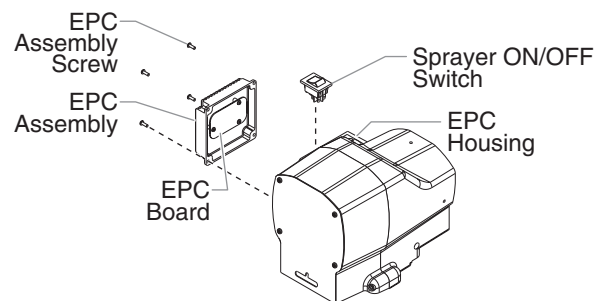

4. Disconnect the switch wires from the sprayer ON/OFF switch. Remember the locations of each of the two wires (label the wires, if necessary).
5. Depress the mounting tabs on each corner of the sprayer ON/OFF switch inside the EPC housing and remove the switch through the top of the housing.
6. Snap the new sprayer ON/OFF switch into the switch hole in the EPC housing.
7. Connect the two switch wires to the new sprayer ON/OFF switch. Make sure the wires are connected to the corresponding terminals from which they were removed (refer to the labels created earlier in this procedure or the electrical schematic in the Parts List section of this manual).
8. Carefully place the EPC assembly over the EPC housing taking care not to pinch any wires.
9. Install the four screws that secure the EPC assembly to the EPC housing. Tighten securely.

Replacing the Transducer

WARNING

Electrostatic discharge (ESD) potential could cause damage to electronic pressure control. Use SprayTECH ESD wrist strap P/N 0507958 or equivalent when working on electronic pressure control.

1. Perform the Pressure Relief Procedure.
2. Using a Phillips screwdriver, remove the four screws that secure the electronic pressure control (EPC) assembly to the EPC housing. Carefully remove the EPC assembly from the housing. Gently move the assembly away from the sprayer and allow the assembly to hang from the housing.
3. Locate the transducer wire in the EPC housing. This wire will be protruding from a hole in the lower left hand corner of the EPC housing. Disconnect this wire from the EPC board (it has a phone jack-style connector).
4. Break off the locking tab from the phone jack-style connector at the end of the transducer wire.
5. Using a 7/8" open-end wrench, loosen and remove the fluid hose from the fitting on the bottom of the filter assembly.
6. Remove the return hose from the fitting on the bottom of the filter assembly.
7. Using a 1/2" socket, remove the two hex screws that secure the filter assembly to the cart.
8. Lift the filter assembly off the cart so that the transducer tube moves out of the hole in the gear housing. Gently pull the transducer wire through the housing until it is fully disengaged from the hole.
9. Mount the filter assembly in a vise for easy access to the transducer.

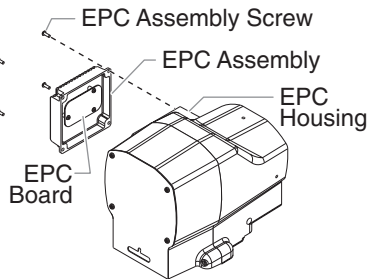

CAUTION

Do not over-tighten the vise.

10. Using a 3/4" open-end wrench, turn the transducer nut counterclockwise to remove the transducer from the filter housing.
11. Locate the new transducer. Make sure that there is a white, Teflon o-ring on the end of the transducer that gets inserted into the filter housing.
12. Insert the transducer into the filter housing port. Rotate the transducer nut clockwise to tighten it into the filter housing. Torque the nut to 360–400 in./lbs.
13. Remove the filter assembly from the vise.

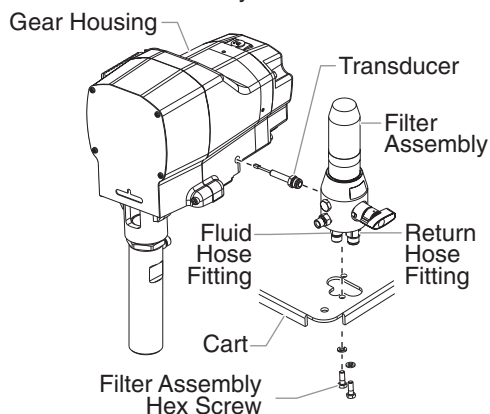

14. Insert the phone jack-style connector on the new transducer wire into the hole in the gear housing from which the old transducer wire was removed. Push the wire and connector until the connector is visible in the EPC housing.
15. Gently pull the wire into the EPC housing while moving the filter assembly to its mounting point on the cart. Guide the end of the transducer tube into the hole in the gear housing.
16. Mount the filter assembly to the cart using the two hex screws and lock washers. Torque the screws to 100–130 in./lbs.
17. Using a 7/8" open-end wrench, attach the fluid hose to the fitting on the bottom of the filter assembly. Tighten securely.
18. Push the return hose firmly into the fitting on the bottom of the filter assembly. Pull on the hose to make sure it has engaged within the fitting.
19. Plug the phone jack-style connector on the transducer wire into the socket on the EPC board from which the old connector was removed.
20. Carefully place the EPC assembly over the EPC housing taking care not to pinch any wires.
21. Install the four screws that secure the EPC assembly to the EPC housing. Tighten securely.
22. Take the sprayer to a SprayTECH Authorized Service Center for re-calibration.
23. After re-calibration, pressurize the system and check for leaks.

Replacing the Electronic Pressure Control (EPC) Assembly

WARNING

Electrostatic discharge (ESD) potential could cause damage to electronic pressure control. Use SprayTECH ESD wrist strap P/N 0507958 or equivalent when working on electronic pressure control.

1. Perform the Pressure Relief Procedure.
2. Using a Phillips screwdriver, remove the four screws that secure the electronic pressure control (EPC) assembly to the EPC housing. Carefully remove the EPC assembly from the housing. Gently move the assembly away from the sprayer and allow the assembly to hang from the housing.
3. Remember the locations of all the wire connections on the EPC board (refer the electrical schematic located in the Parts List section of this manual). If necessary, label all the connections so that they can be replaced in their exact location when the assembly is replaced.
4. Disconnect all the wires from the EPC board.
5. Connect all the wires to the new EPC assembly board (refer to the labels created earlier in this procedure or the electrical schematic in the Parts List section of this manual).
6. Carefully place the EPC assembly over the EPC housing taking care not to pinch any wires.
7. Install the four screws that secure the EPC assembly to the EPC housing. Tighten securely.
8. Take the sprayer to a SprayTECH Authorized Service Center for re-calibration.

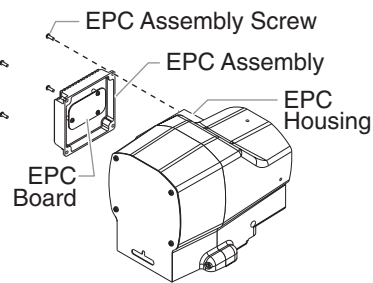

Replacing the Slider Assembly and Slider Housing

1. Start the engine (refer to the procedures in the Operation section of this manual). Turn the pressure control knob clockwise to its maximum pressure setting.
2. Toggle the sprayer ON/OFF switch between the ON and OFF positions in short bursts until the slider assembly stops in a position where the fluid section connecting pin and retaining ring are visible through the slot in the slider housing.

3. Turn off the engine and perform the Pressure Relief Procedure.

4. Using a Phillips screwdriver, remove the four front cover screws. Remove the front cover.
5. Slide the retaining ring up on the slider assembly to expose the connecting pin.
6. Push the connecting pin forward through the slider assembly and piston. The connecting pin will fall out from the rear window of the slider housing where it can be retrieved.

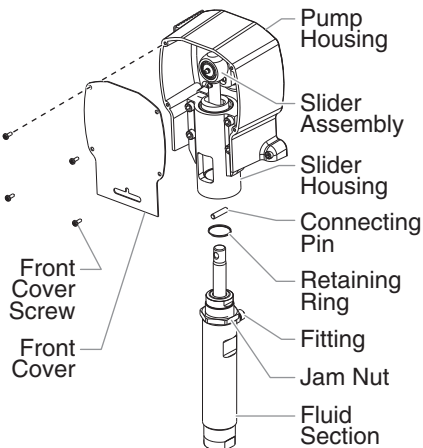

7. Using a 7/8" open-end wrench, loosen and remove the fluid hose from the fitting on the back of the fluid section.
8. Using a 2 1/4" wrench, loosen the fluid section jam nut. Turn the fluid section counterclockwise by until it disengages from the slider housing.
9. Using a 5/16" hex wrench, remove the four socket screws and lock washers that secure the slider housing to the pump housing.
10. Remove the slider housing and slider assembly by pulling it straight out from the pump housing. The slider housing assembly will disengage from the pump housing dowel pins and the connecting rod will disengage from the crankshaft.
11. Remove the slider assembly from the slider housing by grasping the bearing end of the connecting rod and lifting it straight out from the slider housing.
12. Check the parts for wear.
 - a. If the slider housing bushing is scored or out of round it should be replaced.
 - b. If the slider assembly is scored or the connection between the connecting rod and slider assembly exhibits movement other than pivoting movement, the slider assembly should be replaced. The slider assembly also should be replaced if the connecting rod bearing shows signs of wear.
 - c. Any parts that will be reused should be cleaned thoroughly, including the connecting rod. Also, clean the crankshaft pin that the connecting rod bearing rides on.
 - d. If a new slider assembly will be used, remove the retaining ring from the bottom of the old slider assembly and slide it onto the new assembly so that it rests above the connecting pin hole.
13. Lubricate the inside diameter of the slider housing and the outside diameter of the slider assembly with oil. Fill the slider cup with Lubriplate 3000W grease (the slider cup is the area on the slider assembly where the connecting rod and slider housing join and pivot).
14. Insert the slider assembly into the bushing end of the slider housing.

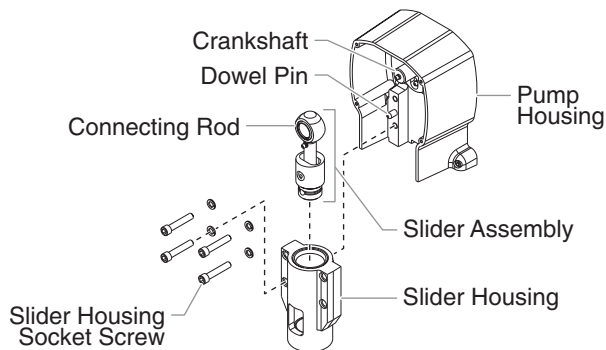

15. Hold the assembly up to the pump housing, lining up the connecting rod with the crankshaft pin and the pump housing dowel pins with their mating holes on the slider housing. Slide the assembly onto the crankshaft pin and pump housing dowel pins until the slider housing bottoms out on the pump housing. Make sure the grease fitting on the connecting rod is facing the open side of the pump housing.
16. Install the the four socket screws and lock washers that secure the slider housing to the pump housing. Tighten in a diagonal pattern and torque to 400–440 in./lbs.
17. Lubricate the connecting rod bearing with Lubriplate 1242 grease by inserting the end of a grease gun onto the grease fitting on the end of the crankshaft pin. Lubricate the main housing bearing by inserting the end of a grease gun onto the grease fitting in the center of the crankshaft. Also, lubricate the connecting rod bushing by inserting the end of a grease gun onto the grease fitting on the connecting rod.
18. Position the front cover over the pump housing. Secure the front cover using the four front cover screws.
19. Apply blue Loctite to the bottom 3–4 threads on the fluid section cylinder.
20. Turn the fluid section jam nut clockwise until it is flush against the top of the cylinder.
21. Lubricate the first several threads at the top of the cylinder with anti-seize compound.
22. Thread the cylinder into the pump housing, turning clockwise. When the connecting pin hole on the piston rod lines up with the hole in the slider assembly, insert the connecting pin.
23. Slide the retaining ring down on the slider assembly to cover the connecting pin.
24. Continue to turn the cylinder clockwise until the jam nut is flush against the slider housing.

NOTE: If the nipple on the cylinder does not face the back of the unit, turn the cylinder counterclockwise until the nipple faces the back of the unit. Do not turn the cylinder more than one full turn.

25. Once the nipple is positioned, turn the jam nut clockwise until it contacts the pump housing.
26. Tighten the jam nut with a wrench to tighten it against the slider housing.
27. Using a 7/8" open-end wrench, attach the fluid hose to the fitting on the back of the fluid section. Tighten securely.

Replacing the Gears

1. Perform the Pressure Relief Procedure.
2. Using a Phillips screwdriver, remove the four front cover screws. Remove the front cover.
3. Using a 7/8" open-end wrench, loosen and remove the fluid hose from the fitting on the back of the fluid section.
4. Locate the four socket screws that secure the pump housing to the gear housing. Two are at the inside top of the pump housing and two are located on the external bosses at the bottom of the pump housing.
5. Using a 1/4" hex wrench, remove the four socket screws that secure the pump housing to the gear housing.
6. Slide the pump housing assembly away from the gear housing.
7. Remove and clean the housing gasket. Replace if damaged.
8. Remove the gear assembly and the 1/4" thrust balls from within the bearing bores that support the gear.

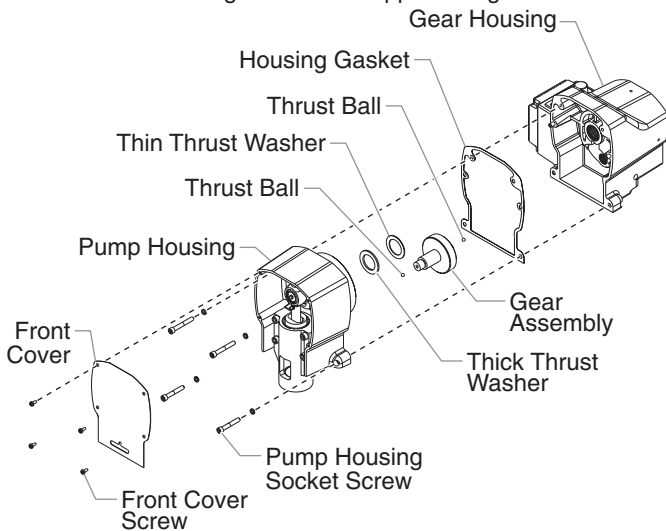

9. Inspect the gears for excessive wear and replace if damaged or worn. If the gear assembly is replaced, replace the two thrust balls as well.
10. Inspect the pinion gear on the end of the drive shaft for wear. Replace if damaged or worn (refer to the "Servicing the Clutch Assembly" procedure in this section).
11. Inspect the output gear and the two thrust washers on the end of the crankshaft in the pump housing for wear. This gear is permanently attached to the crankshaft and pump housing. If this gear is worn, the pump housing must be replaced.

NOTE: If replacing the pump housing, first remove the fluid section, slider housing, and slider assembly from the pump housing (refer to the "Replacing the Slider and Slider Housing" procedure in this section).

12. Replace the thrust washers if worn. If the pump housing assembly is replaced, replace the thrust washers as well.

NOTE: If any of the gears are worn and require replacement, check the grease in the gear housing for metal particles or shavings. Remove the contaminated grease. Replace the grease that has been removed with fresh Lubriplate GR-132 grease.

13. Coat each of the thrust balls with a generous amount of grease. Install the thrust balls — one in the gear housing bore and one in the pump housing bore.
14. Coat the gear assembly with fresh Lubriplate GR-132 grease. Insert the gear assembly into the bore in the pump housing, pinion end first.
15. Generously coat both faces of each of the crankshaft thrust washers with grease.

16. Place the thick thrust washer onto the crankshaft up against the gear hub. Next, place the thin thrust washer up against the thick washer on the crankshaft.
17. Place the housing gasket over the gear housing dowel pins.
18. Carefully place the pump housing assembly in front of the gear housing assembly, lining up the gear housing dowel pins with their corresponding holes in the pump housing. Slide the pump housing onto the gear housing until there is no gap between the housings and gasket.



Do not force the pump housing and gear housing together.

19. Locate the four socket screws and lock washers that secure the pump housing to the gear housing. The longer screws (2.25") are fastened into the top internal holes. The shorter screws (2") are fastened into the bottom external bosses.
20. Using a 1/4" hex wrench, snug and tighten the socket screws in a crossing pattern. Torque to 200–230 in./lbs.
21. If the slider, slider housing, and fluid section were removed, reinstall by following the steps in the "Replacing the Slider and Slider Housing" procedure in this section.
22. Position the front cover over the pump housing. Secure the front cover using the four front cover screws.
23. Using a 7/8" open-end wrench, attach the fluid hose to the fitting on the back of the fluid section. Tighten securely.

Servicing the Clutch Assembly

NOTE: When replacing the clutch armature, the clutch hub and clutch rotor must be replaced also. This will allow for even wear and maximum life on clutch parts.

Removing/Replacing the Clutch Hub and Armature Assembly

1. Perform the Pressure Relief Procedure.
2. Using a 7/8" open-end wrench, loosen and remove the fluid hose from the fitting on the back of the fluid section.
3. Hold the transducer tube with a pliers to prevent it from rotating and turn the transducer nut counterclockwise using a 3/4" open-end wrench. When the nut disengages the filter housing, carefully remove the transducer from the filter housing.
4. Locate the wire that exits the rear of the electronic pressure control (EPC) housing and connects to the wire harness on the engine. Disconnect this wire from its connector at the engine wire harness.
5. Using a 1/2" wrench, remove the four hex screws and lock washers that secure the clutch housing to the gear housing.
6. Using a 9/16" socket, remove the two hex screws that secure the gear housing to the cart.
7. Slide the pump and gear housings away from the engine to disengage them from the clutch housing.

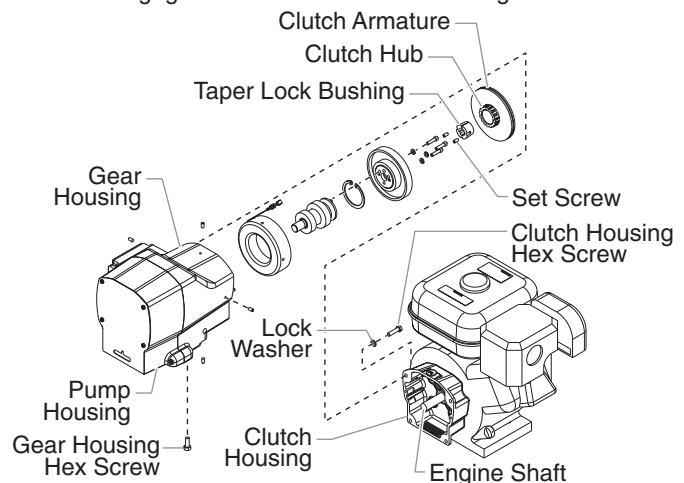

8. Locate the clutch hub and armature assembly on the end of the engine shaft. Note the two set screws as well as the unused, threaded hole in the taper lock bushing at the center of the clutch hub.
9. Using an 1/8" hex wrench, remove the two set screws from the taper lock bushing
10. Thread one of the set screws into the unused, threaded hole on the taper lock bushing. As the screw tightens, the bushing will loosen. Once the bushing has loosened enough, slide the clutch hub and armature assembly off the engine shaft.
11. Before replacing the clutch hub and armature assembly the proper "set back" must be created. Using the SprayTECH hub set-up tool (P/N 0509925), create a "set back" of 0.20" between the friction surface of the clutch armature and the forward face of the clutch hub.

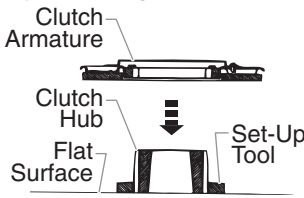

NOTE: A new clutch hub and armature assembly will come pre-assembled, but the "set back" will not be correct. The "set back" must still be created using the hub set-up tool.

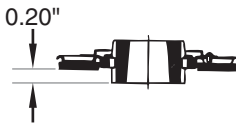

12. Line up the three holes in the taper lock bushing with the three holes in the clutch hub and insert the bushing into the center of the clutch hub.
13. Line up the key on the taper lock bushing with the keyway on the engine shaft and slide the assembly onto the shaft with the holes facing out.
14. Apply blue Loctite to the two set screws and insert the screws into the taper lock bushing. Tighten the set screws only two turns at this time.
15. Line up the forward face of the clutch hub with the front face of the clutch housing. Using an 1/8" hex wrench, alternately tighten the set screws into the taper lock bushing. Torque to 65–75 in/lbs.

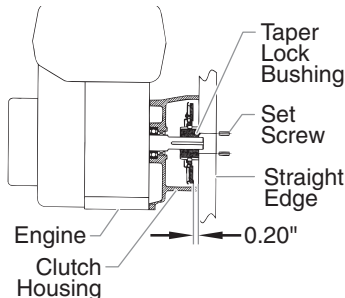

NOTE: To ensure the clutch hub and the clutch housing are aligned, hold a straight edge across the face of the clutch housing and then hold the clutch hub against the back of the straight edge while tightening the two set screws into the taper lock bushing.

16. Make sure the friction surface of the clutch armature is clean and free from oil or grease.

Removing the Clutch Rotor, Clutch Field, and Drive Shaft Assembly

1. Follow steps 1–7 in "Removing/Replacing the Clutch Hub and Armature Assembly."
2. Locate the clutch rotor assembly on the end of the drive shaft assembly. Note the locations of the three socket screws and the two empty, threaded holes on the clutch rotor.
3. Using a 3/16" hex wrench, remove the three socket screws and lock washers that secure the clutch rotor to the drive shaft assembly.
4. Thread two of the socket screws into the empty, threaded holes and tighten alternately. This will push the clutch rotor away from the drive shaft assembly and pinion.

WARNING

Electrostatic discharge (ESD) potential could cause damage to electronic pressure control. Use SprayTECH ESD wrist strap P/N 0507958 or equivalent when working on electronic pressure control.

5. Using a Phillips screwdriver, remove the four screws that secure the EPC assembly to the EPC housing. Carefully remove the EPC assembly from the housing.
6. Locate the two clutch field wires that pass from the gear housing into the EPC housing through a grommet in the back of the EPC housing. Remember the wire connection terminals on the EPC assembly (label if necessary) and disconnect the wires. Gently move the EPC assembly away from the housing and rest it on the work surface by the control housing.
7. Locate the four set screws that secure the clutch field to the gear housing. They are located on the exterior of the gear housing at the 12, 3, 6, and 9 o'clock positions while facing the clutch field end of the gear housing. Using an 1/8" hex wrench, remove the setscrews. Remember the location of the two clutch field wires with respect to the grommet and EPC housing.
8. Carefully slide the clutch field out of the gear housing, keeping the field square to the gear housing so it does not bind.
9. Remove the retaining ring in front of the ball bearing within the center bore of the gear housing.
10. Follow steps 2–6 in the "Replacing the Gears" procedure to remove the pump housing from the gear housing.
11. From the gear side of the gear housing, use a soft hammer to tap the gear end of the drive shaft through the gear housing.
12. Carefully slide the drive shaft assembly out from the gear housing, keeping the shaft square to the housing so it does not bind.
13. Remove the o-ring from inside the center bore of the gear housing from which the small ball bearing on the drive shaft assembly was removed.
14. Clean the inside of the gear housing.

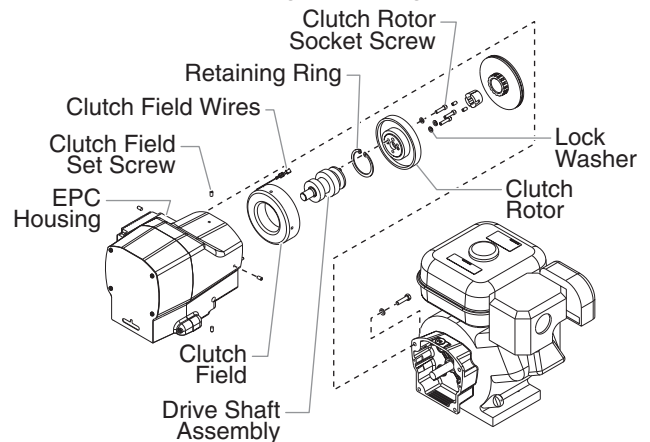

Installing the Clutch Rotor Assembly, Clutch Field and Drive Shaft Assembly

1. Install a new o-ring into the center bore of the gear housing.
2. Apply Loctite retaining compound #635 to the outside diameter of the large bearing on the drive shaft. Do not get retaining compound on the faces of the bearing.
3. Install the drive shaft assembly into the center bore of the gear housing, keeping it square to the housing so it does not bind. Once the large ball bearing on the drive shaft assembly is half way into its bore, a soft hammer may be used to gently tap the assembly into position.

CAUTION

Do not force the drive shaft assembly into position.

4. Install the retaining ring into its groove next to the large ball bearing.
5. Line up the four holes around the outside of the clutch field with the four set screw holes in the gear housing. The clutch field wires should be at approximately the 1 or 2 o'clock position.

- Route the two clutch field wires through the grommet and into the EPC housing.
- Carefully slide the clutch field into its bore in the gear housing until it “bottoms out” within the housing. Do not pinch the clutch field wires during installation.

NOTE: Apply blue Loctite to the four clutch field set screws prior to installation.

- Thread one of the set screws into its hole. Using an 1/8” hex wrench, rotate the screw slowly until it contacts the clutch field. **Do not tighten the set screw.** The tip of the set screw should mate with the drill point hole in the field. Check the clutch field for rotation. If it rotates within its bore, the set screw is not seated within the drill point.
- When the set screw is properly seated, install the remaining three set screws. **Do not tighten the set screws.**
- Using a crossing pattern, tighten each of the setscrews until they are snug. Once all four set screws are snug, use a crossing pattern to tighten and torque the set screws to 30–40 in./lbs.

CAUTION

It is very important to evenly snug, tighten, and torque the clutch field set screws in a crossing pattern. This ensures the clutch field will stay centered in the gear housing.

- Line up the three screw holes and dowel pin hole on the clutch rotor with the screw holes and dowel pin on the drive shaft assembly hub. Place the clutch rotor onto the hub.
- Using a 3/16” hex wrench, thread the three socket screws and lock washers through the clutch rotor and into the drive shaft assembly hub. Evenly snug, tighten, and torque the socket screws to 75–85 in./lbs.
- Make sure the friction surface of the clutch rotor is clean and free from oil or grease.
- Follow steps 17–20 in the “Replacing the Gears” procedure to mate the pump housing with the gear housing.

WARNING

Electrostatic discharge (ESD) potential could cause damage to electronic pressure control. Use SprayTECH ESD wrist strap P/N 0507958 or equivalent when working on electronic pressure control.

- Locate the two clutch field wires in the EPC housing. Gently pull the wires fully into the EPC housing so that there is no slack in the gear housing. Connect the wires to their proper terminals on the EPC board (refer to the labels created earlier in this procedure or the electrical schematic in the Parts List section of this manual).
- Carefully place the EPC assembly over the EPC housing taking care not to pinch any wires.
- Install the four screws that secure the EPC assembly to the EPC housing. Tighten securely.

Mating the Gear Housing and the Clutch Housing

- Place the gear housing assembly onto the cart in front of the clutch housing. Line up the dowel pins in the gear housing with their corresponding holes in the clutch housing. Slide the gear housing assembly onto the clutch housing until there is no gap between the housings.
- Thread the four hex screws and lock washers through the clutch housing and into the gear housing.
- Using a 1/2” wrench, snug and tighten the hex screws in a crossing pattern. Torque to 140–155 in./lbs.
- Using a 9/16” socket, thread the two hex screws that secure the gear housing to the cart through the underside of the cart and into the gear housing. Torque to 100–120 in./lbs.
- Connect the wire from the EPC housing to its mating connector on the engine wire harness.

- Make sure that there is a white Teflon o-ring on the end of the transducer that gets inserted into the filter housing. Insert the transducer into the filter housing port.
- Hold the transducer tube with a pliers to prevent it from rotating, and turn the transducer nut clockwise with a 3/4” open-end wrench to tighten it into the filter housing. Torque the nut to 360–400 in./lbs.

Checking the Clutch Gap

- Remove the plastic plug from the top of the clutch housing. Look through the port to locate the clutch armature and the clutch rotor.
- Check the gap between the clutch armature and the clutch rotor using a .016” feeler gauge and a .035” feeler gauge.
 - Insert each feeler gauge through the port and into the gap between the clutch armature and the clutch rotor. The .016” feeler gauge should fit in the gap. The .035” feeler gauge should not fit in the gap.
 - Pull the engine pull cord several times to rotate the clutch armature, checking the gap with each feeler gauge between each pull.
 - If the .016” gauge does not fit or the .035” gauge does fit at any checkpoint, the gap must be readjusted. This is done by relocating the clutch hub and armature assembly on the engine shaft. Refer to the “Removing/Replacing the Clutch Hub and Armature Assembly” procedure.

Servicing the Fluid Section

Use the following procedures to service the valves and repack the fluid section.

- Start the engine (refer to the procedures in the Operation section of this manual). Turn the pressure control knob clockwise to its maximum pressure setting.
- Toggle the sprayer ON/OFF switch between the ON and OFF positions in short bursts until the slider assembly stops in a position where the fluid section connecting pin and retaining ring are visible through the slot in the slider housing.
- Turn off the engine and perform the Pressure Relief Procedure.

WARNING

Before proceeding, follow the Pressure Relief Procedure outlined previously in this manual. Additionally, follow all other warnings to reduce the risk of an injection injury, injury from moving parts or electric shock.

- Remove the suction set from the swivel fitting at the bottom of the fluid section. Remove the swivel fitting from the fluid section.
- Loosen and remove the fluid hose from the fitting on the back of the cylinder of the fluid section.
- Loosen and remove the four front cover screws. Remove the front cover.
- Slide the retaining ring up on the slider assembly to expose the connecting pin.
- Push the connecting pin forward through the slider assembly and piston. The connecting pin will fall out from the rear window of the slider housing where it can be retrieved.

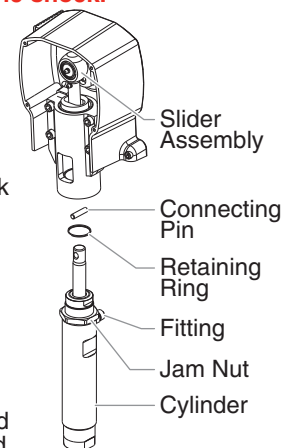

9. Using a wrench, turn the jam nut counterclockwise to loosen it from the pump housing.
10. Turn the fluid section counterclockwise to remove it from the pump housing.
11. Place the fluid section cylinder upright in a vise by clamping on the wrench flats.

NOTE: Do not over-tighten the vise. Damage to the cylinder may occur.

12. Loosen and remove the inlet valve housing from the cylinder.
13. Remove the inlet cage, inlet valve ball, inlet valve seat, and o-ring from the inlet valve.
14. Clean out any debris in the inlet valve housing and examine the housing and the inlet valve seat. If the seat is damaged, reverse to the unused side or replace the seat.
15. Remove the splash guard from the top of the upper seal retainer.
16. Using a wrench, remove the upper seal retainer.
17. Slide the piston rod out through the bottom of the cylinder.

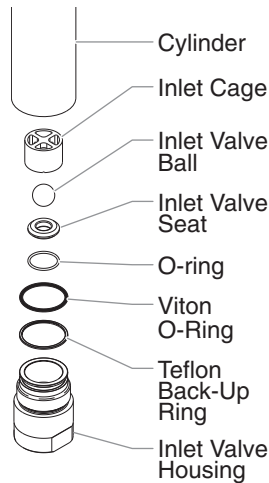

18. Inspect the piston rod for wear and replace if necessary.
19. Remove the upper packing assembly from the top of the cylinder.
20. Remove the lower support ring and lower packing assembly from the bottom of the cylinder.

NOTE: Be careful not to scratch, score, or otherwise damage the cylinder during removal of the packing assemblies.

21. Remove the cylinder from the vise.
22. Insert the connection pin through the hole at the top of the piston rod and clamp each end of the connecting pin in the vise. This will hold the piston rod in position for disassembly.

NOTE: Do not clamp the piston rod directly in the vise. Damage to the piston rod will occur.

23. Using a 3/8" hex wrench, loosen and remove the outlet valve retainer from the piston rod.
24. Remove the outlet valve seal, outlet cage, outlet valve ball, nylon washer, and outlet valve seat from the outlet valve retainer.
25. Clean out any debris and examine the retainer and outlet valve seat. If the seat is damaged, reverse to the unused side or replace the seat.
26. Clean and inspect the outlet cage and outlet valve ball. Replace if they are worn or damaged.

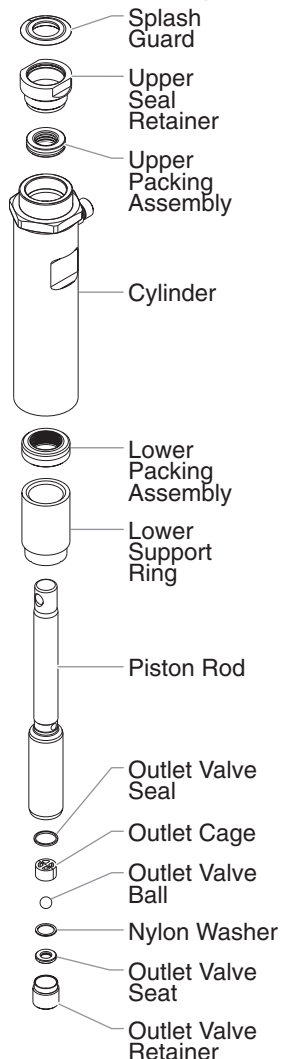

27. Reassemble the outlet valve assembly into the piston rod in the reverse order of how it was disassembled. Torque the outlet valve retainer to 144 in./lbs.
28. Remove the piston rod from the vise.
29. Clean the cylinder. Inspect the cylinder for damage and replace if necessary.
30. Place the cylinder upright in a vise by clamping on the wrench flats.
31. Locate the new upper and lower packing assemblies and pack the areas between the packing lips with grease. Lubricate the o-rings on the exterior of the packings with grease.

32. Insert the upper packing assembly into the top of the cylinder with the large beveled edge facing down.

Install upper packing with large beveled edge facing down.

33. Thread the upper seal retainer into the cylinder but do not tighten.



34. Rotate the cylinder in the vise so that the bottom end is facing up.

35. Pre-form the lower packing using the lower packing sizing tool (included in the repacking kit).

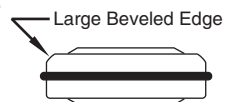

36. Insert the lower packing assembly partially into the bottom of the cylinder with the large beveled edge facing toward the cylinder (beveled edge will be facing up when the cylinder is upright).

Install lower packing so large beveled edge will be facing up when the cylinder is upright.

37. Push the lower packing assembly into position using the lower packing insertion tool (see Fluid Section Assembly parts list for lower packing insertion tool P/N).
38. Place the piston insertion tool (included in the repacking kit) over the top of the piston rod.
39. Insert the piston rod into the bottom of the cylinder, through the lower packing assembly, through the upper packing assembly, and out through the upper seal retainer.
40. Tighten the upper seal retainer. Torque to 300–360 in./lbs.

NOTE: When repacking the fluid section, make sure the raised lip on the bottom of the lower packing assembly is fully outside the packing around the piston rod after insertion of the piston rod.

41. Apply blue Loctite to the bottom 3–4 threads on the cylinder. Turn the jam nut clockwise until it is flush against the top of the cylinder.
42. Lubricate the first several threads at the top of the cylinder with anti-seize compound. Remove the cylinder from vise.
43. Place the splash guard over the top of the piston rod and push down until it is flush against the upper seal retainer.
44. Thread the cylinder into the pump housing, turning clockwise. When the connecting pin hole on the piston rod lines up with the hole in the slider assembly, insert the connecting pin.
45. Slide the retaining ring down on the slider assembly to cover the connecting pin.
46. Continue to turn the cylinder clockwise until the jam nut is flush against the pump housing.

NOTE: If the nipple on the cylinder does not face the back of the unit, turn the cylinder counterclockwise until the nipple faces the back of the unit. Do not turn the cylinder more than one full turn.

47. Once the nipple is positioned, turn the jam nut clockwise until it contacts the pump housing.

48. Tighten the jam nut with a wrench to tighten it against the pump housing.
49. Attach the high-pressure hose to the fitting on the back of the cylinder and tighten with a wrench. Do not kink the hose.
50. Insert the lower support ring into the bottom of the cylinder.
51. Making sure that the Viton o-ring and Teflon back-up ring are lubricated and in place, reassemble the inlet valve assembly and thread it into the cylinder. Tighten the inlet valve housing until the o-ring engages, then continue to tighten until snug. Once snug, tighten an additional 1/8–1/4 turn.
52. Replace the swivel fitting into the bottom of the fluid section. Attach the suction set to the swivel fitting.
53. Place the front cover on the pump housing and secure in position using the four front cover screws.
54. Turn on the sprayer by following the procedure in the “Operation” section of this manual and check for leaks.

NOTE: Repacking kit P/N 0509510 is available. For best results use all parts supplied in this kit.

Troubleshooting

Problem

The unit will not run.

Cause

1. The pressure is set too low.
2. Faulty or loose wiring.
3. The gas tank is empty.

Solution

1. Turn the pressure control knob clockwise to supply power to the unit and increase the pressure setting.
2. Inspect or take to a SprayTECH authorized service center.
3. Fill the gas tank.

The unit will not prime.

1. The PRIME/SPRAY valve is in the SPRAY position.
2. Air leak in the siphon tube/siphon set.
3. The pump filter and/or inlet screen is clogged.
4. The siphon tube/siphon set is clogged.

1. Rotate the PRIME/SPRAY valve clockwise to the PRIME position.
2. Check the siphon tube/siphon set connection and tighten or re-tape the connection with Teflon tape.
3. Remove the pump filter element and clean. Remove the inlet screen and clean.
4. Remove the siphon tube/siphon set and clean.

The unit will not build or maintain pressure.

1. The spray tip is worn.
2. The spray tip is too large.
3. The pressure control knob is not set properly.
4. The pump filter, gun filter, or inlet screen is clogged.
5. Material flows from the return hose when the PRIME/SPRAY valve is in the SPRAY position.
6. Air leak in the siphon tube/siphon set.
7. There is external fluid leak.
8. There is an internal fluid section leak (packings are worn and/or dirty, valve balls are worn).
9. Worn valve seats

1. Replace the spray tip following the instructions that came with the spray gun.
2. Replace the spray tip with a tip that has a smaller orifice following the instructions that came with the spray gun.
3. Turn the pressure control knob clockwise to increase the pressure setting.
4. Remove the pump filter element and clean. Remove the gun filter and clean. Remove the inlet screen and clean.
5. Clean or replace the PRIME/SPRAY valve.
6. Check the siphon tube/siphon set connection and tighten or re-tape the connection with Teflon tape.
7. Check for external leaks at all connections. Tighten connections, if necessary.
8. Clean the valves and service the fluid section following the "Servicing the Fluid Section" procedure in the Maintenance section of this manual.
9. Reverse or replace the valve seats following the "Servicing the Fluid Section" procedure in the Maintenance section of this manual.

Fluid leakage at the upper end of the fluid section.

1. The upper packings are worn.
2. The piston rod is worn.

1. Repack the pump following the "Servicing the Fluid Section" procedure in the Maintenance section of this manual.
2. Replace the piston rod following the "Servicing the Fluid Section" procedure in the Maintenance section of this manual.

Excessive surge at the spray gun.

1. Wrong type of airless spray hose.
2. The spray tip worn or too large.
3. Excessive pressure.

1. Replace hose with a minimum of 50' of 1/4" grounded textile braid airless paint spray hose.
2. Replace the spray tip following the instructions that came with the spray gun.
3. Rotate the pressure control knob counterclockwise to decrease spray pressure.

Poor spray pattern.

1. The spray tip is too large for the material being used.
2. Incorrect pressure setting.
3. Insufficient fluid delivery.
4. The material being sprayed is too viscous.

1. Replace the spray tip with a new or smaller spray tip following the instructions that came with the spray gun.
2. Rotate the pressure control knob to adjust the pressure for a proper spray pattern.
3. Clean all screens and filters.
4. Add solvent to the material according to the manufacturer's recommendations.

The unit lacks power.

1. The pressure adjustment is too low.

1. Rotate the pressure control knob clockwise to increase the pressure setting.

Consignes de sécurité

Le présent manuel comprend des renseignements devant être lus attentivement avant toute utilisation de l'appareil. Lorsque l'un des symboles suivants apparaît, il est recommandé d'être particulièrement attentif et de tenir compte des mesures de sécurité indiquées.

AVERTISSEMENT

Ce symbole indique un danger potentiel pouvant causer des blessures graves ou même mortelles. Des renseignements importants sur la sécurité sont également indiqués.

ATTENTION

Ce symbole indique un danger potentiel pouvant causer des blessures corporelles ou des dommages à l'équipement. Des renseignements importants sur la façon de prévenir tout dommage à l'équipement ou toute blessure corporelle mineure sont également indiqués.

NOTA : Les remarques donnent des renseignements importants requérant une attention particulière.

AVERTISSEMENT

CONSIGNES DE SÉCURITÉ IMPORTANTES

A. CONSERVEZ CES CONSIGNES – Pour réduire les risques d'incendie ou d'explosion, d'électrocution et de blessures, lisez et assurez-vous de bien comprendre toutes les consignes contenues dans ce manuel. Familiarisez-vous avec les commandes et l'usage correct de l'équipement.

B. AVERTISSEMENT – Pour réduire le risque d'incendie ou d'explosion :

1. Ne pulvérisez pas de matières inflammables ou combustibles près d'une flamme nue, de voyants lumineux ou de sources d'ignition telles que des objets chauds, cigarettes, moteurs, matériel et appareils électriques. Évitez de produire des étincelles en connectant et en déconnectant les cordons électriques.
2. Pour les appareils destinés à n'utiliser que des produits à l'eau – Ne pulvérisez pas et ne les nettoyez pas avec des liquides inflammables. Exclusivement pour usage avec liquides à base d'eau.
3. Pour les appareils destinés à un usage exclusif avec des produits à l'eau ou des produits minéraux de type alcool avec un point d'éclair minimum de 21 °C (70 °F) – Ne pulvérisez pas et ne les nettoyez pas avec des liquides ayant un point d'éclair inférieur à 21 °C (70 °F). Le point d'éclair est la température à laquelle un fluide peut produire suffisamment de vapeur pour s'enflammer.
4. L'écoulement de peinture ou de solvant dans l'équipement peut produire de l'électricité statique. L'électricité statique crée un risque d'incendie ou d'explosion en présence de fumées de peinture ou de solvant. Toutes les pièces du système du pulvérisateur, y compris la pompe, l'ensemble du tuyau, le pistolet de pulvérisation et les objets dans et autour de la zone de pulvérisation doivent être correctement reliés à la terre pour protéger contre les décharges d'électricité statique et les étincelles. N'utilisez que des tuyaux conducteurs ou reliés à la terre pour pulvérisateurs de peinture sous vide à haute pression, spécifiés par le fabricant.
5. Vérifiez que tous les conteneurs ou systèmes de stockage sont reliés à la terre pour éviter les décharges d'électricité statique.
6. Connectez à une prise électrique avec prise de terre et utilisez des rallonges électriques reliées à la terre. N'utilisez pas d'adaptateur 3 à 2.

7. N'utilisez pas de peinture ou de solvant contenant du halon, par exemple, le chlore, les agents antimoussure à l'eau de Javel, le chlorure de méthylène et le trichloroéthane. Ils ne sont pas compatibles avec l'aluminium. Contactez le fournisseur de revêtements pour connaître la compatibilité du matériau avec l'aluminium.
8. La zone de pulvérisation doit toujours être bien aérée. Une bonne quantité d'air frais doit constamment traverser la zone de pulvérisation pour éviter les accumulations de vapeurs inflammables. Le système de pompage doit être placé dans une zone bien aérée. Ne pulvérisez pas le système de pompage.
9. Ne fumez pas dans la zone de pulvérisation.
10. N'actionnez pas d'interrupteurs électriques, de moteurs ou autres dispositifs produisant des étincelles dans la zone de pulvérisation.
11. Maintenez la propreté de la zone et veillez à ce qu'elle ne contienne pas de conteneurs de peinture ou de solvant, de chiffons et autres matières inflammables.
12. Sachez ce que contiennent la peinture et les solvants pulvérisés. Lisez les fiches de sécurité du matériel (MSDS) et les étiquettes apposées sur les conteneurs de peintures et de solvants. Respectez les consignes de sécurité du fabricant de peinture et de solvant.
13. Placez la pompe à une distance minimum de 7,62 mètres (25 pieds) de l'objet à pulvériser, dans une zone bien aérée (ajoutez de la longueur de tuyau si besoin est). Les vapeurs inflammables sont souvent plus lourdes que l'air. La zone près du sol doit être très bien aérée. La pompe contient des pièces qui produisent des arcs et émettent des étincelles pouvant enflammer les vapeurs.
14. Le plastique peut causer des étincelles d'électricité statique. N'accrochez aucun plastique dans une zone de pulvérisation fermée. N'utilisez pas de toiles de protection en plastique quand vous pulvérisez une matière inflammable.
15. Ayez un extincteur en bon état de fonctionnement à portée de main.

AVERTISSEMENT

C. AVERTISSEMENT – Pour réduire le risque de pénétration dans la peau :

DANGER :

Blessure par injection – Le jet de fluide à haute pression produit par cet équipement peut transpercer la peau et les tissus sous-jacents, ce qui produit de graves blessures et peut entraîner une amputation. Consultez immédiatement un médecin. NE TRAITEZ PAS UNE INJECTION COMME UNE SIMPLE COUPURE.

1. Ne dirigez pas le pistolet sur et ne pulvérisez pas les personnes ou les animaux.
2. N'approchez pas les mains ni d'autres parties du corps de la sortie du produit. Par exemple, ne tentez pas d'arrêter une fuite avec une partie du corps.
3. Utilisez toujours le protège-embout de la buse. Ne pulvérisez pas sans que le protège-embout de la buse ne soit installé.
4. Utilisez exclusivement un embout de buse spécifié par le fabricant.
5. Prenez garde quand vous nettoyez ou que vous changez les embouts de buse. Si l'embout se bouche pendant que vous pulvérisez, verrouillez TOUJOURS la détente du pistolet, arrêtez la pompe et libérez toute la pression avant de réparer ou de nettoyer l'embout ou le protecteur ou avant de changer d'embout. La pression n'est pas libérée par l'arrêt du moteur. La poignée du robinet-valve PRIME/SPRAY (AMORÇAGE/ PULVÉRISATION) doit être placée sur PRIME pour libérer la pression. Consultez la PROCÉDURE DE LIBÉRATION DE PRESSION décrite dans le manuel de la pompe.

6. Ne laissez pas l'appareil sous tension ou sous pression quand vous vous en éloignez. Quand vous n'utilisez pas l'appareil, éteignez-le et libérez la pression conformément aux instructions du fabricant.
7. La pulvérisation à haute pression peut injecter des toxines dans le corps et causer de graves blessures corporelles. Si une telle injection se produisait, consultez immédiatement un médecin.
8. Vérifiez les tuyaux et les pièces pour détecter des signes d'endommagement : une fuite peut injecter le produit dans la peau. Inspectez le tuyau avant chaque emploi. Changez tous les tuyaux ou pièces endommagés.
9. Ce système peut produire une pression de 3300 PSI / 22.8 MPa. N'utilisez que les pièces de rechange ou les accessoires spécifiés par le fabricant et ayant une pression nominale minimum de 3300 PSI. Ceci est valable pour les embouts de pulvérisation, les protecteurs de buse, les pistolets, les rallonges, les raccords et le tuyau.
10. Verrouillez toujours la détente quand vous ne pulvérisez pas. Vérifiez que le verrou de la détente fonctionne correctement.
11. Vérifiez que toutes les connexions sont bien serrées avant d'utiliser l'appareil.
12. Sachez comment arrêter l'appareil et le dépressuriser rapidement. Soyez bien familiarisé avec les commandes. La pression n'est pas libérée lorsque le moteur est arrêté. La poignée du robinet-valve PRIME/SPRAY (AMORÇAGE/PULVÉRISATION) doit être placée sur PRIME pour libérer la pression. Consultez la PROCÉDURE DE LIBÉRATION DE PRESSION décrite dans le manuel de la pompe.
13. Retirez toujours l'embout de pulvérisation avant de rincer ou de nettoyer le système.

⚠ AVERTISSEMENT

D. AVERTISSEMENT – Pour réduire le risque de blessure :

1. Portez toujours les gants, la protection oculaire, les vêtements et un respirateur ou masque appropriés quand vous peignez. Vapeurs dangereuses – Les peintures, solvants, insecticides et autres matières peuvent être dangereux s'ils sont inhalés ou entrent en contact avec le corps. Les vapeurs peuvent provoquer d'importantes nausées, une perte de connaissance ou un empoisonnement.
2. Ne travaillez pas et ne pulvérisez pas près d'enfants. Éloignez toujours les enfants de l'équipement.
3. Ne travaillez pas avec les bras au-dessus de la tête ni sur un support instable. Appuyez-vous bien sur les deux pieds pour toujours conserver l'équilibre.
4. Soyez attentif et regardez ce que vous faites.
5. N'utilisez pas l'appareil quand vous êtes fatigué ou sous l'influence de drogues ou d'alcool.
6. Ne faites pas de nœuds avec le tuyau et ne le tordez pas trop. Le tuyau à vide peut présenter des fuites suite à l'usure, les nœuds ou les mauvais traitements. Une fuite risque d'injecter du produit dans la peau.
7. N'exposez pas le tuyau à des températures ou des pressions supérieures à celles spécifiées par le fabricant.
8. N'utilisez pas le tuyau pour tirer ou soulever l'équipement.
9. Utilisez la plus basse pression possible pour rincer l'équipement.
10. Respectez tous les codes locaux, étatiques et nationaux qui régulent la ventilation, la prévention d'incendies et le fonctionnement.
11. Les normes de sécurité du gouvernement des États-Unis ont été adoptées dans la loi Occupational Safety and Health Act (OSHA). Ces normes, en particulier la partie 1910 des Normes générales et la partie 1926 des Normes de construction, doivent être consultées.

12. Avant chaque emploi, vérifiez tous les tuyaux pour détecter d'éventuelles coupures, fuites, abrasion ou couvercle bombé. Vérifiez l'état ou le mouvement des accouplements. Changez immédiatement le tuyau si l'une de ces conditions est vérifiée. Ne réparez jamais un tuyau de peinture. Remplacez-le par un tuyau conducteur à haute pression.
13. Ne pulvérisez pas à l'extérieur par temps venteux.
14. Débranchez toujours le cordon électrique de la prise avant de travailler sur l'équipement.

Sécurité des moteurs à essence

⚠ AVERTISSEMENT

Les produits chimiques contenus dans les vapeurs d'échappement de cet appareil sont reconnus par l'État de la Californie (États-Unis) comme étant cancérigènes. Ils peuvent également entraîner des anomalies congénitales ou d'autres dangers pour la santé.

1. Les moteurs Honda sont conçus pour fonctionner en toute sécurité et avec une fiabilité maximale s'ils sont utilisés conformément aux instructions. Veuillez lire et comprendre le manuel de l'utilisateur de Honda avant de faire fonctionner le moteur. Le non-respect de ces consignes peut entraîner des dommages matériels ou des blessures physiques graves.
2. Pour éviter tout risque d'incendie et fournir une ventilation adéquate, placez le moteur à une distance minimale de 1 mètre (3 pieds) des meubles et d'autres équipements pendant son fonctionnement. Ne placez pas d'objets inflammables à côté du moteur.
3. Tenez les enfants et les animaux domestiques à l'écart de la zone de travail; vous éviterez ainsi tout risque de brûlures sur les pièces chaudes du moteur et de blessures entraînées par les accessoires utilisés par le moteur pour son fonctionnement.
4. Sachez comment arrêter rapidement le moteur, et assurez-vous que vous avez bien compris le fonctionnement de toutes les commandes. Ne permettez jamais à une personne de faire fonctionner le moteur sans connaître les instructions nécessaires.
5. L'essence est extrêmement inflammable et explosive dans certaines conditions.
6. Remplissez le réservoir de carburant dans une zone bien ventilée, moteur arrêté. Ne fumez pas et évitez toutes flammes ou étincelles dans la zone de remplissage de carburant ou dans une zone de stockage du carburant.
7. Veillez à ne pas faire déborder le réservoir de carburant. Après remplissage, assurez-vous que le bouchon du réservoir est solidement vissé.
8. Faites attention à ne pas renverser de carburant lors du remplissage du réservoir. Les vapeurs ou les éclaboussures de carburant peuvent s'enflammer. En cas d'éclaboussures, assurez-vous que la zone est bien sèche avant de faire démarrer le moteur.
9. Ne faites jamais fonctionner le moteur dans un endroit fermé ou confiné. Les fumées d'échappement contiennent du monoxyde de carbone qui est un gaz toxique; une exposition prolongée peut entraîner une perte de conscience et peut s'avérer mortelle.
10. Le silencieux devient très chaud pendant le fonctionnement et reste chaud quelque temps après l'arrêt du moteur. Faites attention à ne pas toucher le silencieux tant qu'il est chaud. Pour éviter des brûlures graves ou des risques d'incendie, laissez le moteur refroidir avant de le transporter ou de le ranger à l'intérieur.
11. Ne transportez jamais le moteur si le réservoir est plein.

Precauciones de seguridad

Este manual contiene información que debe leer y comprender antes de usar el equipo. Cuando se encuentre con uno de los siguientes símbolos, asegúrese de observar sus indicaciones de seguridad.

⚠️ ADVERTENCIA

Este símbolo indica la existencia de un peligro potencial que puede causar lesiones graves o la muerte. Después del mismo se incluye información de seguridad importante.

⚠️ PRECAUCION

Este símbolo indica la existencia de un peligro potencial para usted o el equipo. Después del mismo se incluye información importante que indica la forma de evitar daños al equipo o la forma de prevenir lesiones menores.

NOTA: los avisos contienen información importante, présteles especial atención.

⚠️ ADVERTENCIA

INSTRUCCIONES DE SEGURIDAD IMPORTANTES

A. GUARDE ESTAS INSTRUCCIONES – Para reducir el riesgo de incendio o explosión, descarga eléctrica y daños a las personas, lea y comprenda todas las instrucciones incluidas en este manual. Familiarícese con los controles y con el uso adecuado del equipo.

B. ADVERTENCIA – Para reducir el riesgo de incendio o explosión:

1. No pulverice materiales inflamables ni combustibles cerca de llamas desnudas, pilotos o fuentes de ignición como objetos calientes, cigarrillos, motores, equipos eléctricos o electrodomésticos. Evite producir chispas al conectar y desconectar los cables de alimentación.
2. Para unidades que se vayan a utilizar con materiales acuosos — No pulverice ni limpie con líquidos inflamables. Para su uso con líquidos acuosos solamente.
3. Para unidades que se vayan a utilizar solamente con materiales acuosos o de tipo de alcohol mineral con un punto de inflamación mínimo de 21 °C (69,8 °F) — No pulverice ni limpie con líquidos que tengan un punto de inflamación por debajo de 21 °C (69,8 °F). El punto de inflamación es la temperatura a la que un fluido puede producir vapor suficiente como para incendiarse.
4. La pintura o disolvente que pase por el equipo puede producir electricidad estática. La electricidad estática supone un riesgo de incendio o explosión en presencia de emanaciones de pintura o disolvente. Todas las piezas del sistema pulverizador, incluyendo la bomba, el conjunto de mangueras, la pistola pulverizadora y los objetos dentro y alrededor de la zona de pulverización se conectarán a tierra para protegerlos frente a descargas estáticas y chispas. Utilice solamente mangueras para pulverizadores de pintura airless (sin aire) de alta presión conductores o con toma a tierra especificadas por el fabricante.
5. Compruebe que todos los recipientes y sistemas de recogida están conectados a tierra para evitar descargas eléctricas.
6. Conecte a una salida con toma a tierra y utilice cables alargadores puestos a tierra. No utilice un adaptador de 3 a 2.
7. No utilice pintura o disolvente que contenga hidrocarburos halogenados, como cloro, fungicida blanqueador, cloruro de metileno y tricloroetano. No son compatibles con el aluminio. Póngase en contacto con el proveedor del material para conocer su compatibilidad con el aluminio.

8. Mantenga la zona de pulverización bien ventilada. Asegúrese de que circula aire fresco por la zona para evitar que se acumulen vapores inflamables en el aire de la zona de pulverización. Ponga el conjunto de la bomba en una zona bien ventilada. No pulverice el conjunto de la bomba.
9. No fume en la zona de pulverización.
10. No encienda interruptores de luces, motores ni productos similares que puedan producir chispas en la zona de pulverización.
11. Mantenga la zona limpia y despejada de botes de pintura y disolventes, trapos y otros materiales inflamables.
12. Infórmese del contenido de la pintura y de los disolventes que pulverice. Lea las hojas de datos sobre seguridad de los materiales (MSDS) y las etiquetas en los botes de pintura y disolvente. Siga las instrucciones de seguridad del fabricante de la pintura y del disolvente.
13. Coloque la bomba al menos a 7,62 metros (25 pies) del objeto que se va a pulverizar en una zona bien ventilada (añada más manguera si fuera necesario). Los vapores inflamables suelen ser más pesados que el aire. La zona del suelo debe estar muy bien ventilada. La bomba contiene piezas que forman arcos que producen chispas y pueden inflamar los vapores.
14. El plástico puede producir chispas estáticas. Nunca utilice plástico para cercar la zona de pulverización. No utilice cortinas de plástico mientras pulveriza material inflamable.
15. Deberá contar con equipos extintores de incendios que funcionen correctamente.

⚠️ ADVERTENCIA

C. ADVERTENCIA – Para reducir el riesgo de daños en la piel:

PELIGRO:

Lesión causada por inyección. La corriente de líquido a alta presión que produce este equipo puede perforar la piel y tejidos subcutáneos, pudiendo provocar graves lesiones y posibles amputaciones. Visite a un médico inmediatamente. NO TRATE UNA LESIÓN CAUSADA POR INYECCIÓN COMO UN SIMPLE CORTE.

1. No apunte con la pistola ni pulverice sobre ninguna persona ni animal.
2. Mantenga las manos y el resto del cuerpo lejos de la descarga. Por ejemplo, no trate de detener fugas con ninguna parte de su cuerpo.
3. Utilice siempre el protector de la boquilla. No pulverice sin el protector en su sitio.
4. Utilice solamente la boquilla especificada por el fabricante.
5. Tenga cuidado al limpiar y cambiar las boquillas. Si la boquilla se atasca durante la pulverización, ponga SIEMPRE el seguro del gatillo de la pistola, apague la bomba y libere toda la presión antes de reparar, limpiar el protector o la boquilla o cambiar la boquilla. La presión no se libera apagando el motor. Para liberar la presión hay que poner la manija de la válvula PRIME/SPRAY (cebar/pulverizar) en PRIME. Consulte el Procedimiento para liberar presión que se describe en el manual de la bomba.
6. No deje el aparato con corriente ni con presión cuando nadie esté pendiente de ella. Cuando no utilice el aparato, apáguelo y libere la presión siguiendo las instrucciones del fabricante.
7. La pulverización a alta presión puede inyectar toxinas en el cuerpo y producir daños graves en el mismo. En caso de que esto ocurra, visite a un médico inmediatamente.
8. Compruebe las mangueras y las piezas en busca de daños; una fuga puede inyectar material en la piel. Inspeccione la manguera antes de cada uso. Sustituya las mangueras o las piezas dañadas.

9. Este sistema es capaz de producir 3300 PSI / 22.8 MPa. Utilice solamente piezas de repuesto o accesorios especificados por el fabricante y con una capacidad nominal de 3300 PSI como mínimo. Entre ellos se incluyen boquillas pulverizadoras, protectores para las boquillas, pistolas, alargadores, racores y mangueras.
10. Ponga siempre el seguro del gatillo cuando no esté pulverizando. Verifique que el seguro del gatillo funciona correctamente.
11. Antes de utilizar el aparato, verifique que todas las conexiones son seguras.
12. Aprenda a detener el aparato y a liberar la presión rápidamente. Familiarícese a conciencia con los controles. La presión no se libera apagando el motor. Para liberar la presión hay que poner la manija de la válvula PRIME/SPRAY (cebar/pulverizar) en PRIME. Consulte el Procedimiento para liberar presión que se describe en el manual de la bomba.
13. Quite siempre la boquilla pulverizadora antes de enjuagar o limpiar el sistema.

⚠ ADVERTENCIA

D. ADVERTENCIA – Para reducir el riesgo de lesiones:

1. Cuando pinte, lleve siempre guantes, protección para los ojos, ropa y un respirador o máscara adecuados. Vapores peligrosos: Las pinturas, disolventes, insecticidas y otros materiales pueden ser perjudiciales si se inhalan o entran en contacto con el cuerpo. Los vapores pueden producir náuseas intensas, desmayos o envenenamiento.
2. Nunca utilice el aparato ni pulverice cerca de niños. Mantenga el equipo alejado de los niños en todo momento.
3. No se estire demasiado ni se apoye sobre un soporte inestable. Mantenga los pies bien apoyados y el equilibrio en todo momento.
4. No se distraiga y tenga cuidado con lo que hace.
5. No utilice el aparato si está fatigado o se encuentra bajo la influencia del alcohol o de las drogas.
6. No retuerza ni doble la manguera en exceso. En la manguera airless pueden aparecer fugas a causa del desgaste, de retorcimientos o de un mal uso. Una fuga puede inyectar material en la piel.
7. No exponga la manguera a temperaturas o presiones que superen las especificadas por el fabricante.
8. No utilice la manguera como elemento de fuerza para tirar del equipo o levantarlo.
9. Utilice la presión más baja posible para enjuagar el equipo.
10. Cumpla todos los reglamentos locales, estatales y nacionales pertinentes relativos a ventilación, prevención de incendios y funcionamiento.
11. Las normas sobre seguridad del gobierno de los Estados Unidos se han adoptado al amparo de la Ley de salud y seguridad ocupacional (OSHA). Deben consultarse tres normas, particularmente la sección 1910 de las Normas generales y la sección 1926 de las Normas sobre construcción.
12. Cada vez que vaya a utilizar el equipo, compruebe antes todas las mangueras en busca de cortes, fugas, abrasión o bultos en la cubierta. Compruebe el movimiento de los acoplamientos y si están dañados. Sustituya inmediatamente una manguera si descubre alguna de estas anomalías. No repare nunca una manguera de pintura. Sustitúyala por una manguera conductora a alta presión.
13. No pulverice al aire libre si hace viento.
14. Desenchufe siempre el cable antes de trabajar en el equipo.

Seguridad del motor de gasolina

⚠ ADVERTENCIA

El escape del motor de esta unidad contiene productos químicos que el Estado de California reconoce que causan cáncer, defectos congénitos u otros daños a la reproducción.

1. Los motores Honda han sido diseñados para ofrecer un servicio seguro y fiable, si son manejados de acuerdo con las instrucciones. Lea y comprenda el Manual del Propietario de Honda antes de hacer funcionar el motor. Si no hace esto, podrían producirse lesiones personales o daños en el equipo.
2. Para evitar riesgos de incendio y proporcionar una ventilación adecuada, mantenga el motor como mínimo a 1 metro (tres pies) de edificios y de otros equipos durante su funcionamiento. No coloque objetos inflamables cerca del motor.
3. Los niños y los animales de compañía deben mantenerse alejados del área de trabajo, debido a la posibilidad de quemaduras producidas por los componentes calientes del motor o de daños producidos por el equipo al que haga funcionar el motor.
4. Conozca el modo de detener rápidamente el motor, y entienda el funcionamiento de todos los controles. No permita que nadie haga funcionar el motor sin las instrucciones adecuadas.
5. La gasolina es extremadamente inflamable y es explosiva en determinadas circunstancias.
6. Reabastézcase de combustible en una zona bien ventilada y con el motor apagado. No fume ni permita que haya llamas ni chispas en el área de reabastecimiento de combustible ni donde se almacene la gasolina.
7. No llene excesivamente el tanque de combustible. Tras repostar, asegúrese de que la tapa del tanque está adecuadamente cerrada y asegurada.
8. Tenga cuidado de no derramar combustible cuando realice el reabastecimiento. Los vapores del combustible o el combustible derramado pueden inflamarse. Si se derrama combustible, asegúrese de que el área esté seca antes de arrancar el motor.
9. Nunca haga funcionar el motor en un área cerrada o reducida. Los gases de escape contienen monóxido de carbono tóxico: su exposición puede causar la pérdida del conocimiento y puede originar la muerte.
10. El silenciador se calienta mucho durante el funcionamiento y permanece caliente durante un tiempo después de que el motor esté parado. Tenga cuidado de no tocar el silenciador mientras está caliente. Para evitar quemaduras graves o riesgos de incendio, deje que el motor se enfríe antes de transportarlo o almacenarlo en el interior.
11. Nunca transporte una unidad con gasolina en el tanque.

Parts List

Main Assembly

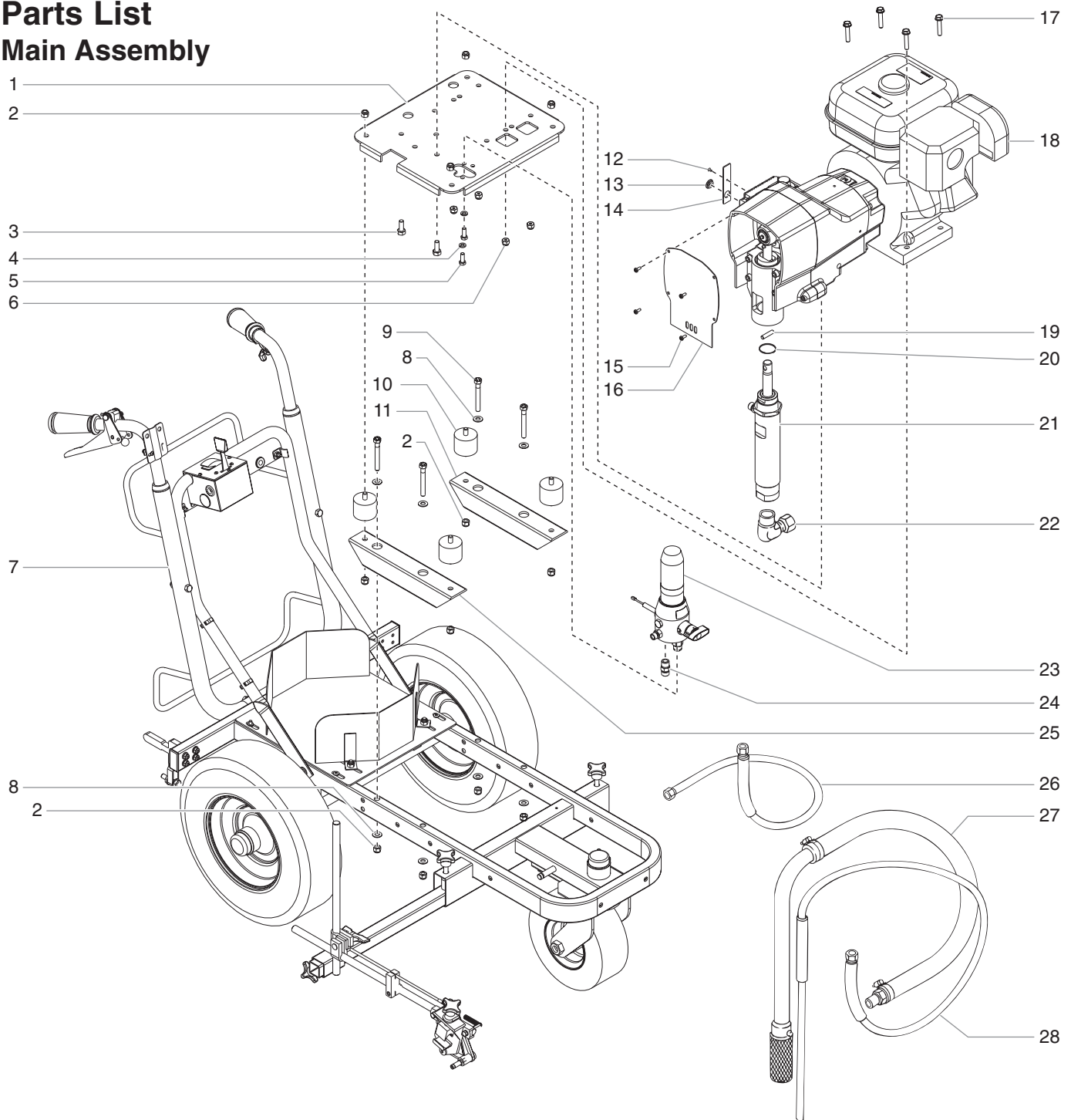

| Item | Part # | Description | Quantity | Item | Part # | Description | Quantity |
|------|---------|--------------------------|----------|------|---------|---|----------|
| 1 | 0509658 | Pump mounting plate..... | 1 | 17 | 0509244 | Hex screw..... | 4 |
| 2 | 0509293 | Lock nut..... | 12 | 18 | ----- | Drive assembly (see separate listing)..... | 1 |
| 3 | 0509286 | Hex screw..... | 2 | 19 | 0507520 | Connecting pin..... | 1 |
| 4 | 0509860 | Lock washer..... | 2 | 20 | 0509521 | Retaining ring..... | 1 |
| 5 | 0509861 | Hex screw..... | 2 | 21 | 0509133 | Fluid section assembly..... | 1 |
| 6 | 0509551 | Lock nut..... | 4 | 22 | 0509727 | Swivel elbow..... | 1 |
| 7 | 0509161 | Cart assembly..... | 1 | 23 | ----- | Filter assembly (see separate listing)..... | 1 |
| 8 | 0509285 | Flat washer..... | 8 | 24 | 5000527 | Nipple..... | 1 |
| 9 | 0509862 | Hex screw..... | 4 | 25 | 0509786 | Spacer tube, right..... | 1 |
| 10 | 0509770 | Vibration mount..... | 4 | 26 | 0507387 | Fluid hose..... | 1 |
| 11 | 0509787 | Spacer tube, left..... | 2 | 27 | 0509297 | Siphon set..... | 1 |
| 12 | 0509635 | Screw..... | 1 | 28 | 0509173 | Return hose assembly..... | 1 |
| 13 | 0509634 | Port plug..... | 1 | 29 | 0296366 | Spray gun (not shown)..... | 1 |
| 14 | 0509627 | Control cover..... | 1 | 30 | 0091708 | Tip assembly (not shown)..... | 1 |
| 15 | 0509863 | Screw..... | 4 | 31 | 0291000 | Material hose, 1/4" x 50' (not shown)..... | 1 |
| 16 | 0509187 | Front cover w/label..... | 1 | | | | |

Drive Assembly

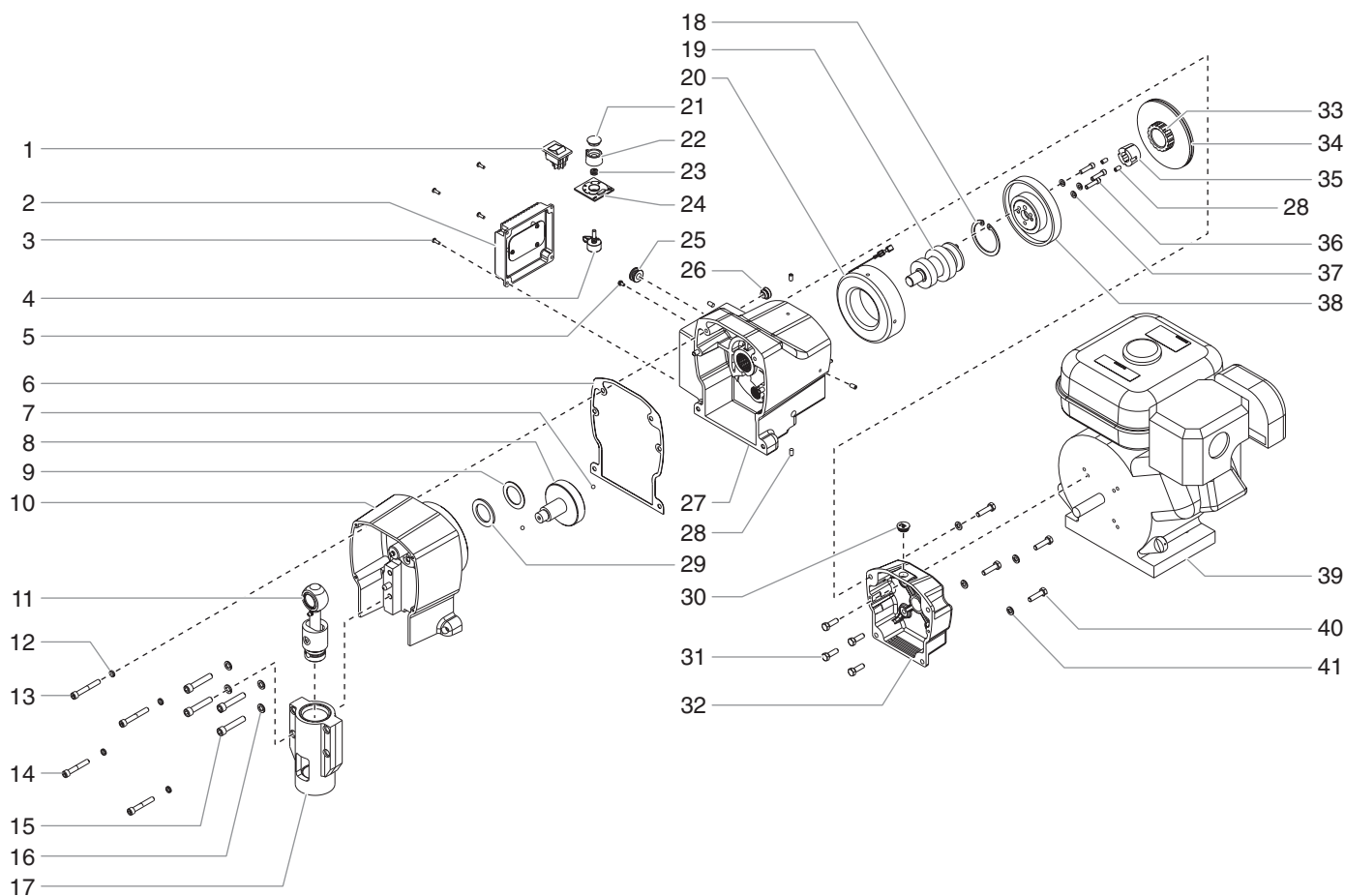

| Item | Part # | Description | Quantity |
|------|---------|--------------------------------------|----------|
| 1 | 9850936 | ON/OFF switch | 1 |
| 2 | 0509558 | Electronic pressure control assembly | 1 |
| 3 | 0509556 | Screw | 4 |
| 4 | 0507973 | Potentiometer | 1 |
| 5 | 9800340 | Ground screw | 1 |
| 6 | 0509495 | Gasket | 1 |
| 7 | 0509562 | Ball | 2 |
| 8 | 0509564 | Gear assembly | 1 |
| 9 | 0509559 | Thrust washer | 1 |
| 10 | 0555187 | Pump housing | 1 |
| 11 | 0509134 | Slider assembly | 1 |
| 12 | 0509541 | Washer | 4 |
| 13 | 0509539 | Socket screw, 2.25" | 2 |
| 14 | 0509540 | Socket screw, 2" | 2 |
| 15 | 0509561 | Socket screw | 4 |
| 16 | 53171 | Lock washer | 4 |
| 17 | 0509132 | Slider housing | 1 |
| 18 | 0509565 | Retaining ring | 1 |
| 19 | 0509567 | Drive shaft assembly | 1 |
| 20 | 0555902 | Clutch field assembly | 1 |
| 21 | 0507748 | Cap | 1 |

| Item | Part # | Description | Quantity |
|------|---------|--|----------|
| 22 | 0507740 | Pressure control knob | 1 |
| 23 | 0507749 | Seal nut | 1 |
| 24 | 0509557 | Mounting plate | 1 |
| 25 | 0507784 | Grommet, 7/16" | 1 |
| 26 | 0509531 | Grommet, liquid tight | 1 |
| 27 | 0555189 | Gear housing | 1 |
| 28 | 0509573 | Set screw | 6 |
| 29 | 0509563 | Thrust bearing | 1 |
| 30 | 0509574 | Plug | 1 |
| 31 | 0509538 | Screw | 4 |
| 32 | 0555633 | Clutch housing | 1 |
| 33 | 0509619 | Clutch hub | 1 |
| 34 | 0509570 | Clutch hub and armature (includes items 28(2), 33, and 35) | 1 |
| 35 | 0509571 | Taper lock bushing (includes item 28(2)) | 1 |
| 36 | 0509566 | Socket screw | 3 |
| 37 | 0295694 | Lock washer | 3 |
| 38 | 0509568 | Clutch rotor | 1 |
| 39 | 0555617 | Engine | 1 |
| 40 | 0509569 | Hex screw | 4 |
| 41 | 0507786 | Lock washer | 4 |

NOTE: All electrical work should be performed by a SprayTECH authorized service center.

Cart Assembly (P/N 0509161)

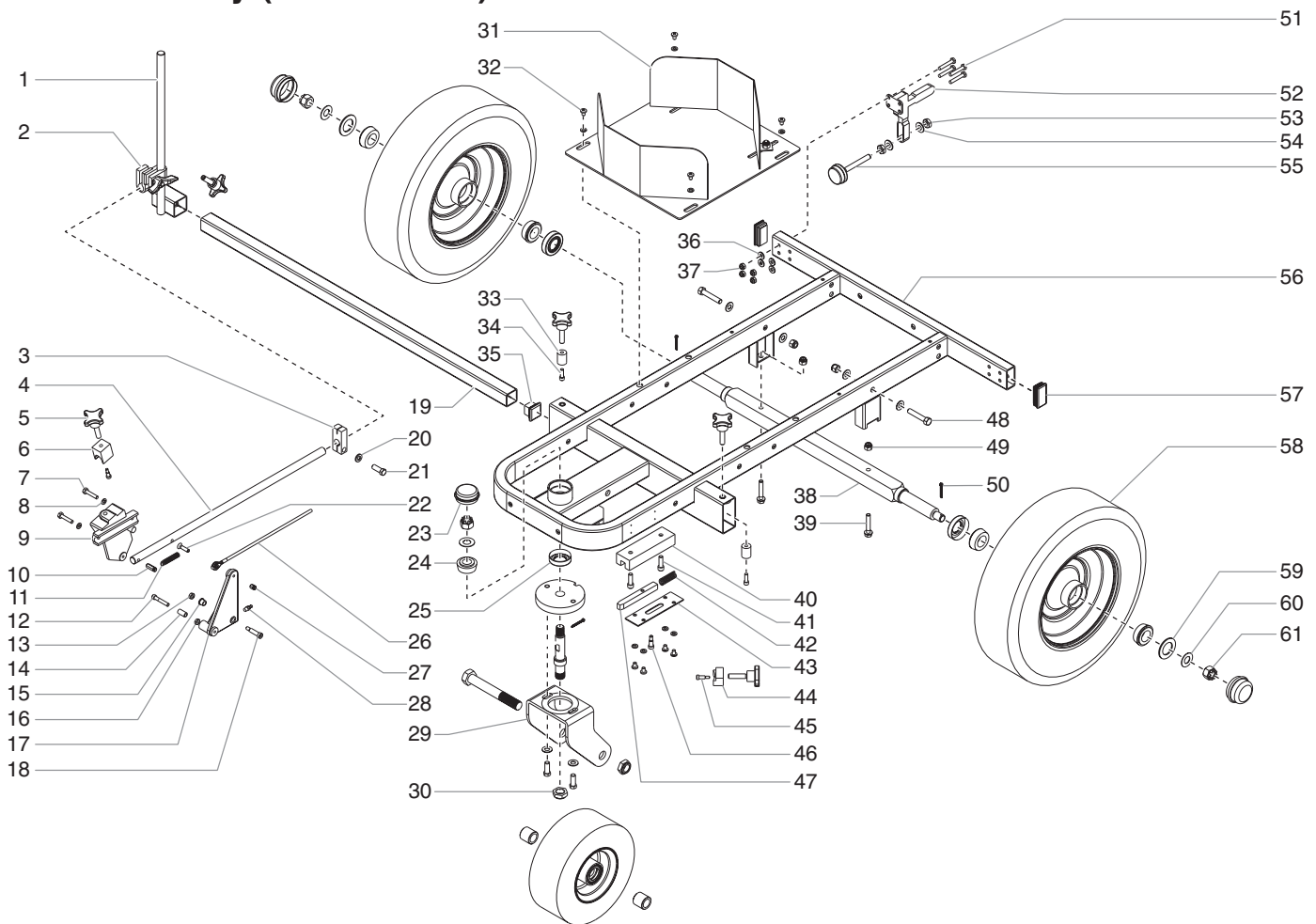

| Item | Part # | Description | Quantity |
|------|---------|-----------------------------|----------|
| 1 | 0509232 | Slide tube weldment..... | 1 |
| 2 | 0509261 | Clamp assembly..... | 1 |
| 3 | 0509208 | Cable mounting clamp | 1 |
| 4 | 0509207 | Support arm..... | 1 |
| 5 | 0555317 | Clamping knob | 5 |
| 6 | 0555324 | Clamp block..... | 1 |
| 7 | 0509775 | Screw | 2 |
| 8 | 0509772 | Lock washer, 1/4"..... | 10 |
| 9 | 0509201 | Gun holder..... | 1 |
| 10 | 0509242 | Spring holder (long)..... | 1 |
| 11 | 0509781 | Return spring..... | 1 |
| 12 | 0509776 | Shoulder screw..... | 1 |
| 13 | 0509773 | Jam nut..... | 1 |
| 14 | 0509214 | Sleeve bearing | 1 |
| 15 | 0509213 | Flange bearing | 2 |
| 16 | 0509774 | Jam nut..... | 1 |
| 17 | 0509202 | Lever | 1 |
| 18 | 0509778 | Shoulder screw..... | 1 |
| 19 | 0509229 | Gun support bar | 1 |
| 20 | 0509292 | Lock washer | 1 |
| 21 | 0509286 | Screw | 1 |
| 22 | 0509220 | Screw | 1 |
| 23 | 0509263 | Dust cap..... | 1 |
| 24 | 0509260 | Taper bearing | 2 |
| 25 | 0509262 | Taper bearing seal..... | 1 |
| 26 | 0509275 | Gun cable | 1 |
| 27 | 0509241 | Spring holder (short) | 1 |
| 28 | 0509210 | Grease fitting..... | 1 |
| 29 | 0509250 | Caster assembly..... | 1 |
| 30 | 0509251 | Lock nut, 3/4" | 1 |
| 31 | 0555738 | Bucket holder | 1 |

| Item | Part # | Description | Quantity |
|------|---------|-----------------------|----------|
| 32 | 0509219 | Screw | 8 |
| 33 | 0509230 | Clamp rod..... | 2 |
| 34 | 0509243 | Screw | 2 |
| 35 | 0509231 | Plastic end cap..... | 1 |
| 36 | 0509246 | Flat washer..... | 4 |
| 37 | 0509245 | Lock nut, 1/4" | 7 |
| 38 | 0509253 | Axle | 1 |
| 39 | 0509244 | Hex screw..... | 2 |
| 40 | 0509268 | Guide block | 1 |
| 41 | 0509222 | Socket screw | 2 |
| 42 | 0509228 | Lock spring..... | 1 |
| 43 | 0509234 | Block cover..... | 1 |
| 44 | 0509254 | Block..... | 1 |
| 45 | 0555326 | Shoulder screw..... | 2 |
| 46 | 0509236 | Shoulder screw..... | 1 |
| 47 | 0509272 | Caster lock pin | 1 |
| 48 | 0509845 | Screw | 2 |
| 49 | 0509551 | Lock nut, 5/16" | 2 |
| 50 | 0509226 | Cotter pin..... | 3 |
| 51 | 0509846 | Screw | 4 |
| 52 | 0509216 | Brake clamp | 1 |
| 53 | 0509847 | Nut..... | 2 |
| 54 | 0509848 | Flat washer..... | 2 |
| 55 | 0509849 | Brake pad | 1 |
| 56 | 0509252 | Frame | 1 |
| 57 | 0509270 | Plastic plug..... | 2 |
| 58 | 0509850 | Rear wheel | 2 |
| 59 | 0509851 | Washer..... | 2 |
| 60 | 0509227 | Spring washer | 3 |
| 61 | 0509225 | Castle nut | 3 |

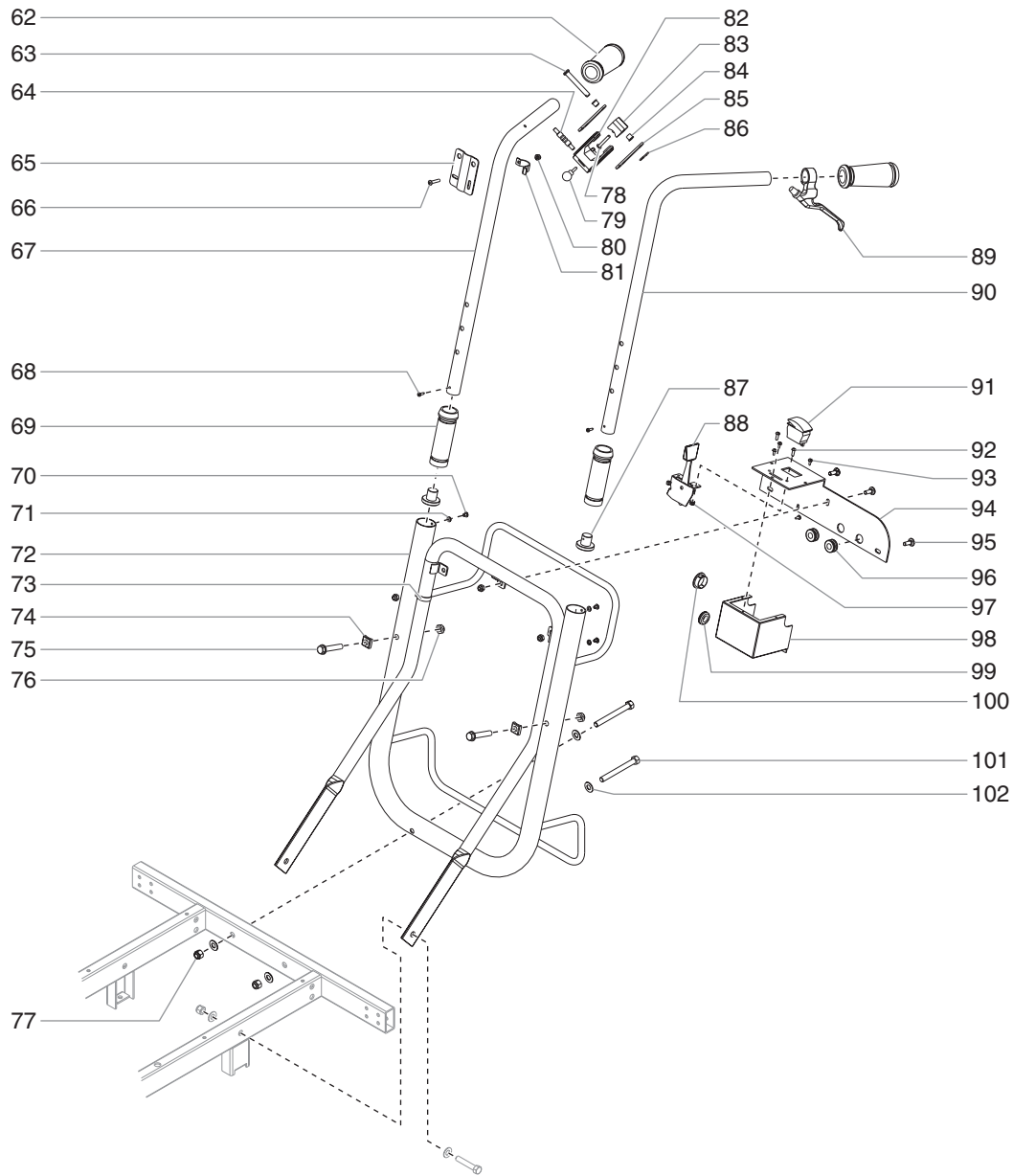

| Item | Part # | Description | Quantity | Item | Part # | Description | Quantity |
|------|---------|-------------------------|----------|------|---------|--------------------------------|----------|
| 62 | 0509211 | Grip..... | 2 | 84 | 0509205 | Flange bearing | 2 |
| 63 | 0509235 | Clevis pin..... | 1 | 85 | 0509204 | Lever plate..... | 2 |
| 64 | 0509209 | Selector spool..... | 1 | 86 | 0509239 | Cotter pin..... | 1 |
| 65 | 0509237 | Cable guide plate | 1 | 87 | 0509259 | Handle guide | 2 |
| 66 | 0509233 | Screw | 1 | 88 | 0509264 | Throttle control | 1 |
| 67 | 0509255 | Handle bar, right..... | 1 | 89 | 0509278 | Front caster lever | 1 |
| 68 | 0509221 | Screw | 2 | 90 | 0509257 | Handle bar, left..... | 1 |
| 69 | 0295607 | Handle sleeve..... | 2 | 91 | 0509265 | Kill switch..... | 1 |
| 70 | 0509852 | Screw | 4 | 92 | 0509218 | Screw | 2 |
| 71 | 0509853 | Lock washer | 4 | 93 | 0509276 | Screw | 4 |
| 72 | 0509256 | Handle assembly..... | 1 | 94 | 0509258 | Control plate..... | 1 |
| 73 | 0509212 | Cable clip..... | 1 | 95 | 0509247 | Carriage screw | 3 |
| 74 | 0509266 | Screw block..... | 2 | 96 | 0509857 | Grommet | 2 |
| 75 | 0509845 | Screw | 2 | 97 | 0509858 | Lock nut..... | 2 |
| 76 | 0509854 | Nut..... | 2 | 98 | 0509782 | Control panel housing | 1 |
| 77 | 0509293 | Lock nut, 3/8" | 4 | 99 | 0509249 | Grommet | 1 |
| 78 | 0509855 | Screw | 2 | 100 | 0509785 | Plug | 1 |
| 79 | 0509238 | Clamp knob | 1 | 101 | 0509859 | Screw | 2 |
| 80 | 0509856 | Lock nut..... | 1 | 102 | 0509285 | Flat washer..... | 8 |
| 81 | 0509240 | Strap..... | 1 | 103 | 0509731 | Cable (not shown) | 1 |
| 82 | 0509203 | Gun trigger lever | 1 | 104 | 0509785 | Hole plug (not shown) | 1 |
| 83 | 0509206 | Mounting block..... | 1 | | 0509987 | Pail lid (optional, not shown) | |

Fluid Section Assembly (P/N 0509133)

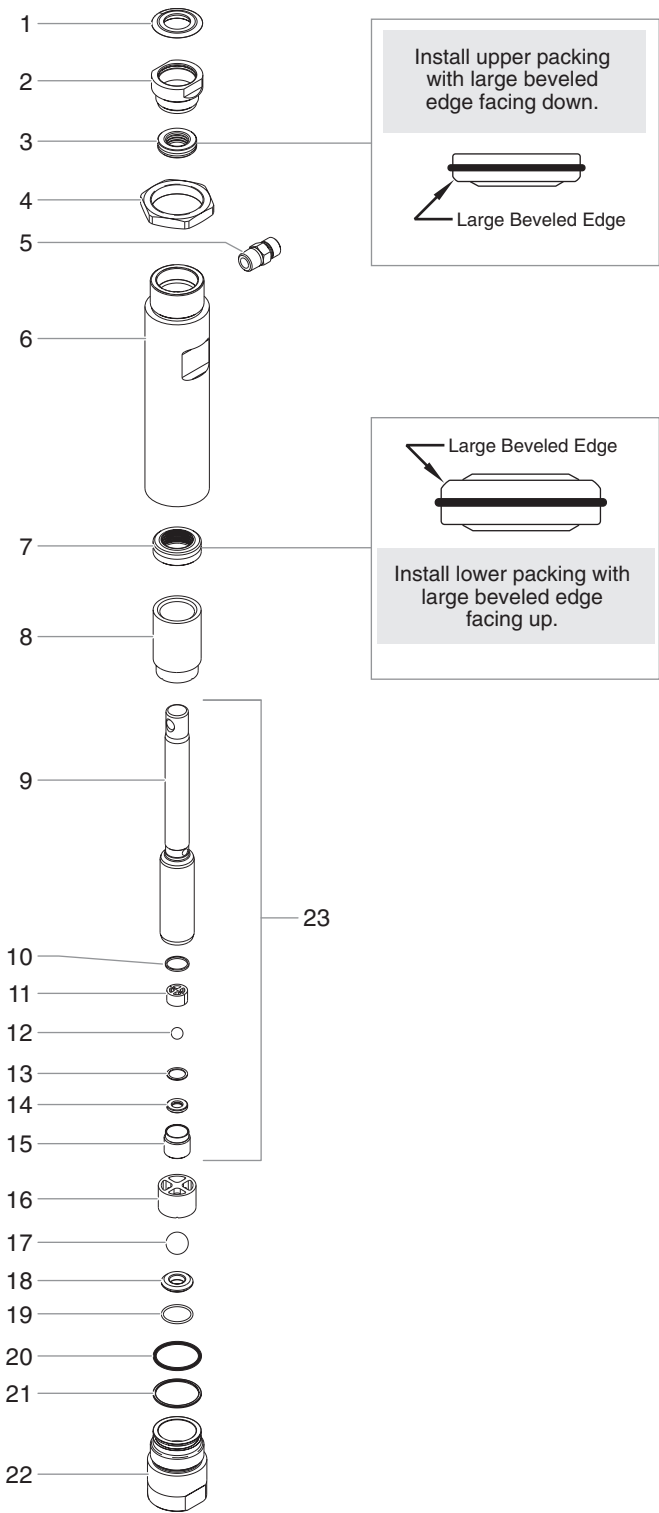

| Item | Part # | Description | Quantity |
|------|---------|--|----------|
| 1 | 0509555 | Splash guard..... | 1 |
| 2 | 0509554 | Upper seal retainer | 1 |
| 3 | 0509912 | Upper packing assembly | 1 |
| 4 | 0509505 | Jam nut..... | 1 |
| 5 | 0508343 | Fitting, 3/8"..... | 1 |
| 6 | 0509914 | Cylinder..... | 1 |
| 7 | 0509911 | Lower packing assembly | 1 |
| 8 | 0509511 | Lower support ring..... | 1 |
| 9 | 0509913 | Piston..... | 1 |
| 10 | 0507734 | Outlet valve seal | 1 |
| 11 | 0507452 | Outlet cage | 1 |
| 12 | 9841502 | Outlet valve ball | 1 |
| 13 | 0507454 | Nylon washer..... | 1 |
| 14 | 0294516 | Outlet valve seat..... | 1 |
| 15 | 0507733 | Outlet valve retainer | 1 |
| 16 | 0507729 | Inlet cage | 1 |
| 17 | 51519 | Inlet valve ball..... | 1 |
| 18 | 00310 | Inlet valve seat..... | 1 |
| 19 | 00203 | O-ring, Teflon | 1 |
| 20 | 0507730 | Viton o-ring | 1 |
| 21 | 0507731 | Back-up ring, Teflon..... | 1 |
| 22 | 0507728 | Foot valve | 1 |
| 23 | 0509135 | Piston assembly (includes items 9–15) | 1 |
| | 0509510 | Repacking kit (includes items 3, 7, 10, 12, 13, 17, 19, 20, and 21) | |
| | 0509927 | Lower packing insertion tool | |

NOTE: When repacking the fluid section, make sure the raised lip on the bottom of the lower packing is fully outside the packing around the piston rod after insertion of the piston rod.

Electrical Schematic

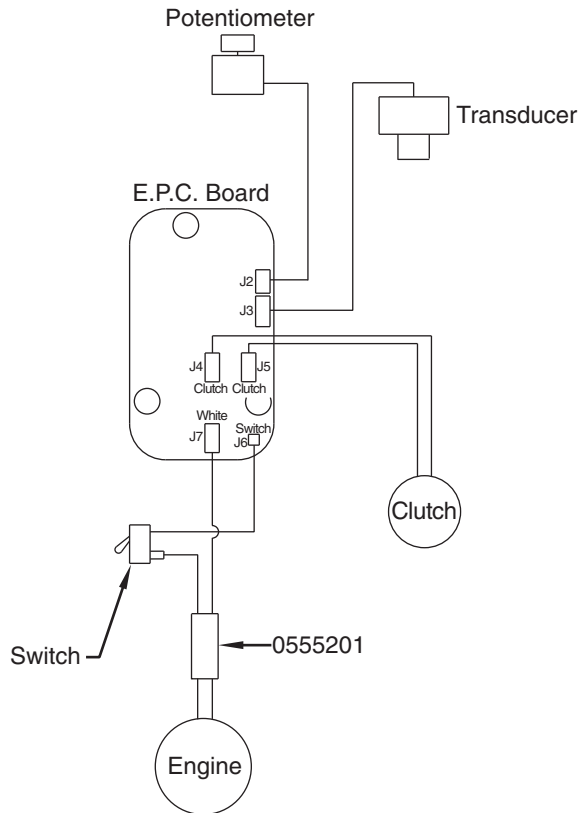

Filter Assembly

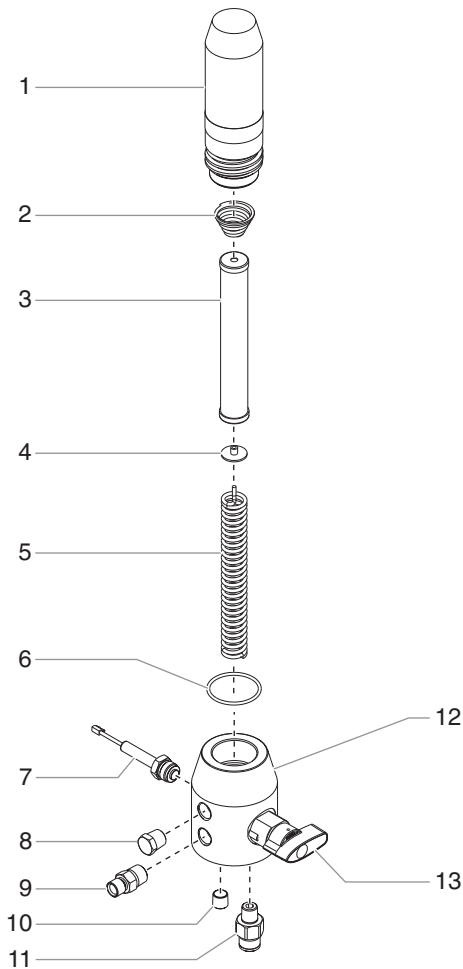

| Item | Part # | Description | Quantity |
|------|---------|---------------------------------|----------|
| 1 | 0508723 | Filter body | 1 |
| 2 | 0508602 | Filter spring | 1 |
| 3 | 0508748 | Filter, 60 mesh (standard)..... | 1 |
| | 0508451 | Filter, 30 mesh (optional) | |
| | 0508452 | Filter, 100 mesh (optional) | |
| 4 | 0508603 | Adapter | 1 |
| 5 | 0508749 | Filter support spring | 1 |
| 6 | 0508725 | O-ring, Teflon | 1 |
| 7 | 0507737 | Transducer..... | 1 |
| 8 | 0509420 | Plug, 3/8" | 1 |
| 9 | 5000527 | Outlet fitting, 1/4" | 1 |
| 10 | 0295697 | Plug, 1/4" | 1 |
| 11 | 0507793 | Fitting, 1/4" | 1 |
| 12 | 0555625 | Filter housing | 1 |
| 13 | 0507690 | PRIME/SPRAY valve assembly..... | 1 |

PRIME/SPRAY Valve Assembly (P/N 0507690)

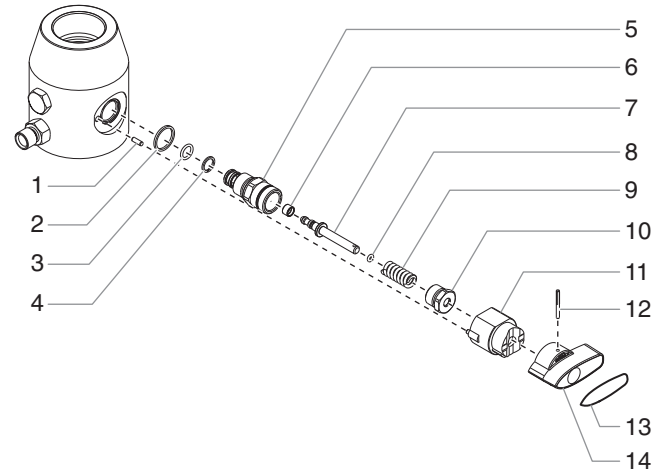

| Item | Part # | Description | Quantity |
|------|---------|-----------------------|----------|
| 1 | 0507736 | Dowel pin | 1 |
| 2 | 0507745 | Gasket | 1 |
| 3 | 5000529 | O-ring, Teflon | 1 |
| 4 | 0507741 | O-ring, Viton..... | 1 |
| 5 | 0507744 | Valve housing | 1 |
| 6 | 0507746 | Valve seat | 1 |
| 7 | 0507743 | Valve stem | 1 |
| 8 | 5006547 | O-ring, Viton..... | 1 |
| 9 | 0507747 | Spring | 1 |
| 10 | 0507742 | Valve retainer..... | 1 |
| 11 | 0507735 | Cam base | 1 |
| 12 | 5006543 | Groove pin | 1 |
| 13 | 0508330 | Label, SprayTECH..... | 1 |
| 14 | 0507662 | Valve handle | 1 |

Caster Assembly (P/N 0509250)

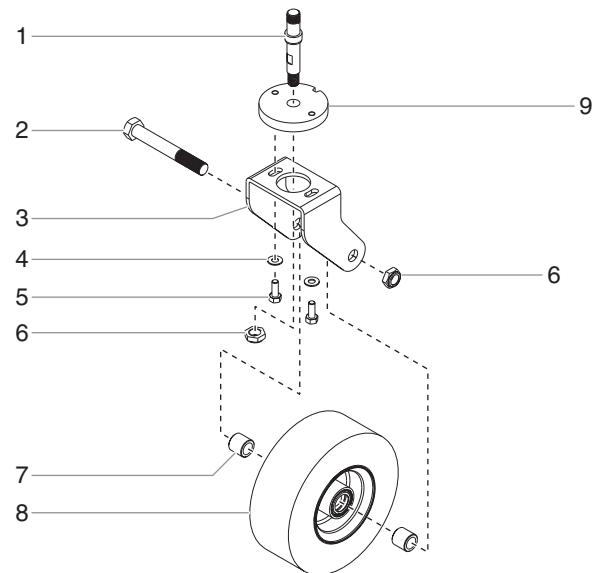

| Item | Part # | Description | Quantity |
|------|---------|---------------------|----------|
| 1 | 0509281 | Shaft | 1 |
| 2 | 0509284 | Axle | 1 |
| 3 | 0509279 | Frame | 1 |
| 4 | 0509285 | Flat washer | 2 |
| 5 | 0509286 | Hex screw | 2 |
| 6 | 0509251 | Lock nut | 2 |
| 7 | 0509283 | Spacer | 2 |
| 8 | 0509282 | Wheel..... | 1 |
| 9 | 0509280 | Locating ring | 1 |

Siphon Set (P/N 0509297)

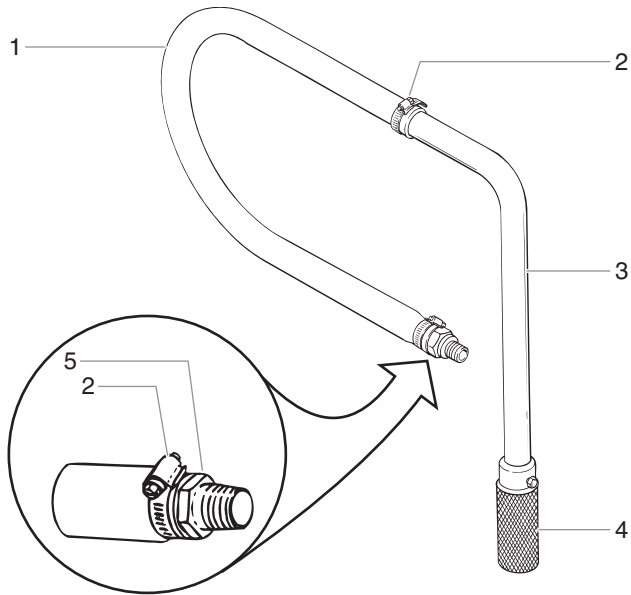

| Item | Part # | Description | Quantity |
|------|---------|--------------------|----------|
| 1 | 0509298 | Hose, 52"..... | 1 |
| 2 | 0509761 | Hose clamp..... | 2 |
| 3 | 0509763 | Tube..... | 1 |
| 4 | 0509762 | Intake screen..... | 1 |
| 5 | 0509760 | Adapter..... | 1 |

Return Hose Assembly (P/N 0509173)

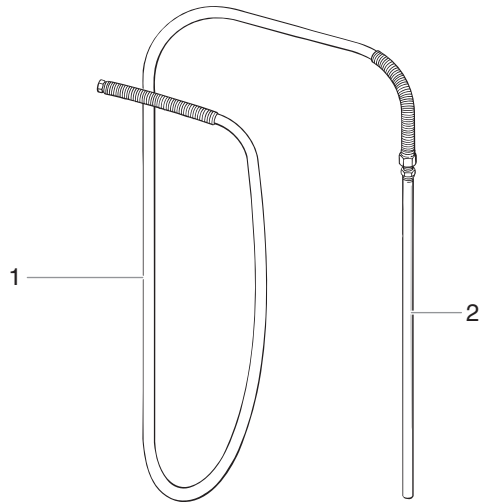

| Item | Part # | Description | Quantity |
|------|---------|--------------------|----------|
| 1 | 0509746 | Hose assembly..... | 1 |
| 2 | 0509764 | Tube..... | 1 |

Labels

| Part # | Description |
|---------|---------------------------------|
| 0555894 | Logo label, front |
| 0509865 | Safety label |
| 0509866 | Warning label |
| 0509867 | Fire and Explosion Hazard label |
| 0295805 | Shock Hazard label |
| 0509819 | "No Oil" label |

Accessories

Turf Kit (P/N 0509965)

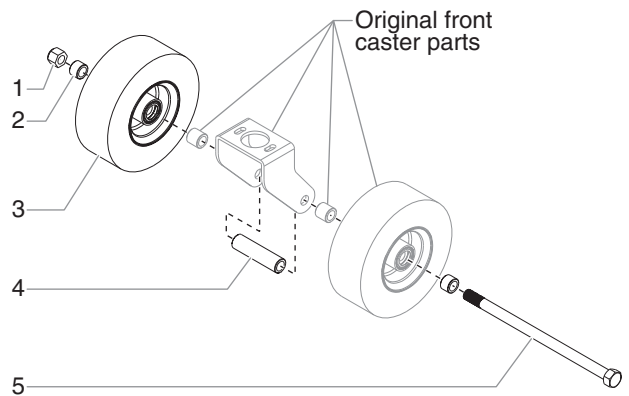

| Item | Part # | Description | Quantity |
|------|---------|-----------------|----------|
| 1 | 0509971 | Lock nut..... | 1 |
| 2 | 0509972 | Spacer..... | 2 |
| 3 | 0509282 | Wheel..... | 1 |
| 4 | 0509973 | Spacer..... | 1 |
| 5 | 0509970 | Axle shaft..... | 1 |

12 Gallon Paint Hopper (P/N 0509943)

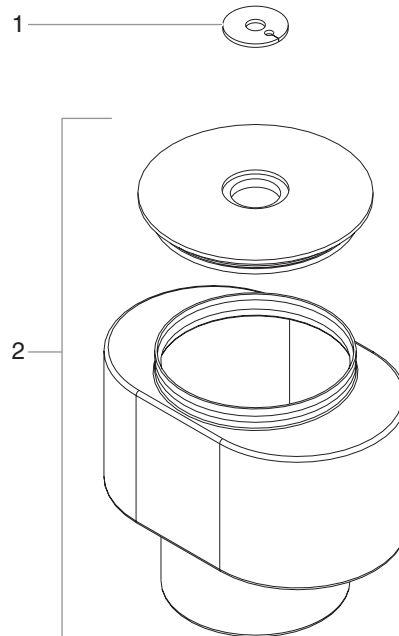

| Item | Part # | Description | Quantity |
|------|---------|---------------------|----------|
| 1 | 0509877 | Seal..... | 1 |
| 2 | 0509981 | Hopper w/cover..... | 1 |

Second Gun Kit (P/N 0509941)

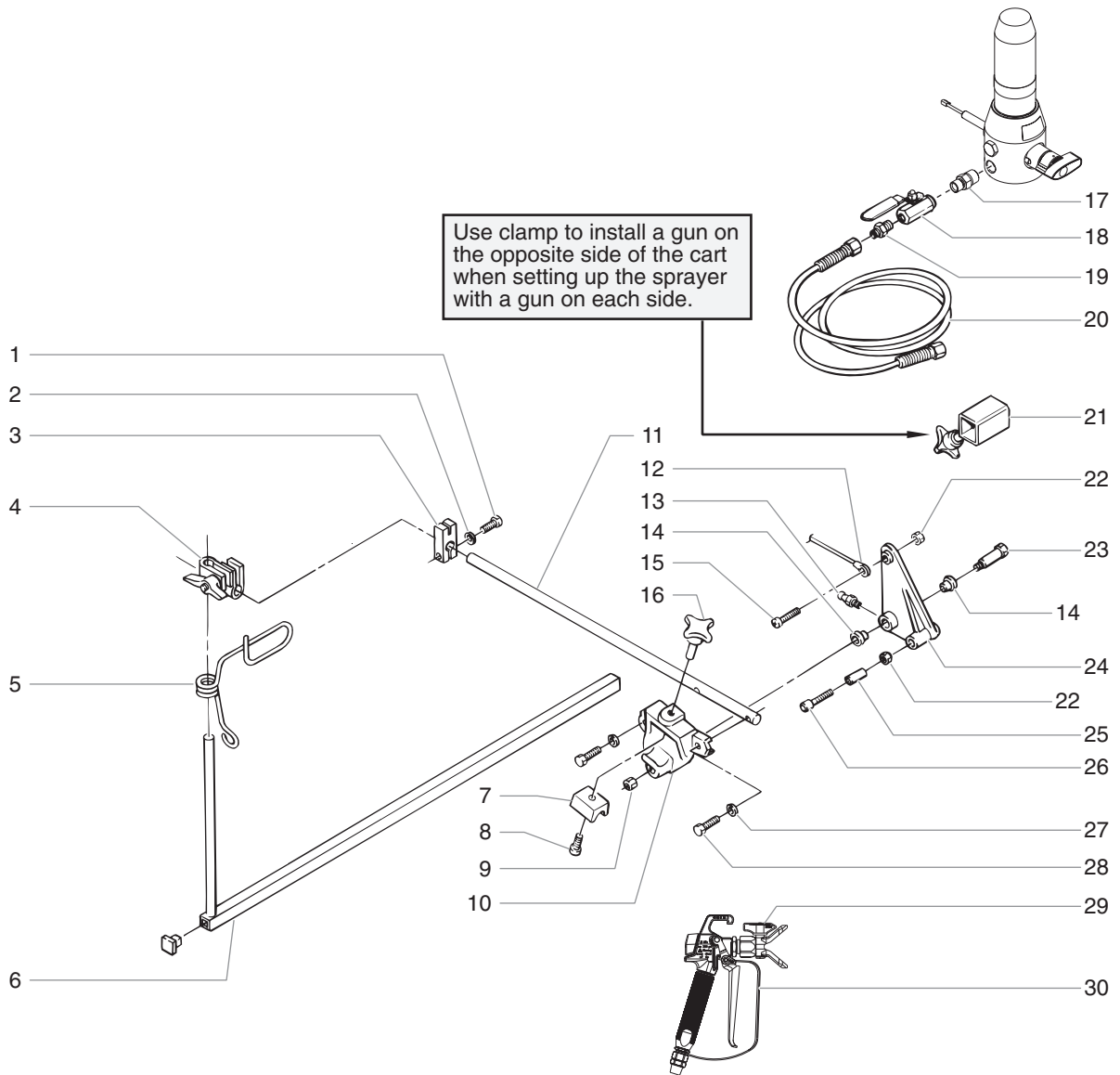

| Item | Part # | Description | Quantity |
|------|---------|----------------------|----------|
| 1 | 0509286 | Hex screw | 1 |
| 2 | 0509292 | Lock washer | 1 |
| 3 | 0509208 | Cable mounting clamp | 1 |
| 4 | 0509261 | Clamp assembly | 1 |
| 5 | 0509217 | Cable guide | 1 |
| 6 | 0509871 | Extension bar | 1 |
| 7 | 0555324 | Clamp | 1 |
| 8 | 0555326 | Screw, shoulder | 1 |
| 9 | 0509773 | Nut | 1 |
| 10 | 0509201 | Gun holder | 1 |
| 11 | 0509207 | Support arm | 1 |
| 12 | 0509275 | Gun control cable | 1 |
| 13 | 0509210 | Grease fitting | 1 |
| 14 | 0509213 | Flanged bearing | 2 |
| 15 | 0509220 | Screw | 1 |

| Item | Part # | Description | Quantity |
|------|---------|--------------------|----------|
| 16 | 0555317 | Knob | 2 |
| 17 | 0509876 | Fitting | 1 |
| 18 | 0509872 | Ball valve | 1 |
| 19 | 0509873 | Hex nipple | 1 |
| 20 | 0509874 | Hose assembly, 6' | 1 |
| 21 | 0509875 | Clamp | 1 |
| 22 | 0509774 | Nut | 2 |
| 23 | 0509778 | Screw, shoulder | 1 |
| 24 | 0509202 | Actuator lever | 1 |
| 25 | 0509214 | Sleeve bearing | 1 |
| 26 | 0509776 | Screw, socket head | 1 |
| 27 | 0509772 | Lock washer | 2 |
| 28 | 0509775 | Screw, hex head | 2 |
| 29 | 0091908 | Tip assembly | 1 |
| 30 | 0296359 | Airless gun | 1 |

Floating Gun Mount (P/N 0509942)

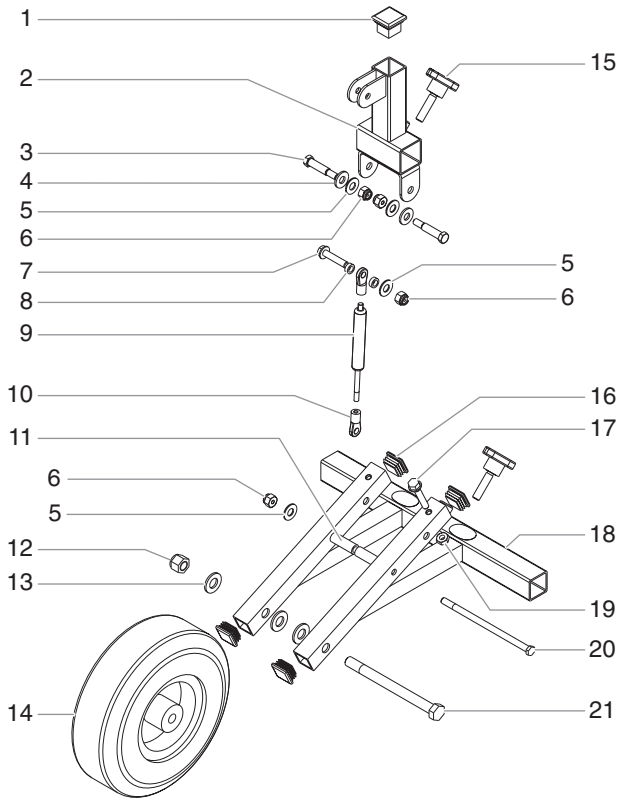

| <u>Item</u> | <u>Part #</u> | <u>Description</u> | <u>Quantity</u> |
|-------------|---------------|------------------------------|-----------------|
| 1 | 0509231 | Cap..... | 1 |
| 2 | 0509948 | Support assembly..... | 1 |
| 3 | 0509949 | Shoulder screw..... | 2 |
| 4 | 0509950 | Washer, nylon..... | 2 |
| 5 | 0295614 | Flat washer..... | 4 |
| 6 | 0509551 | Lock nut..... | 4 |
| 7 | 0509550 | Hex screw..... | 1 |
| 8 | 0509953 | Upper spacer..... | 2 |
| 9 | 0509954 | Gas spring..... | 1 |
| 10 | 0509955 | Eyelet..... | 2 |
| 11 | 0509956 | Lower spacer..... | 2 |
| 12 | 0507549 | Lock nut..... | 1 |
| 13 | 0509958 | Flat washer..... | 3 |
| 14 | 0509959 | Wheel..... | 1 |
| 15 | 0555317 | Clamping knob..... | 2 |
| 16 | 0509960 | Plug..... | 4 |
| 17 | 0509244 | Travel adjustment screw..... | 1 |
| 18 | 0509961 | Frame assembly..... | 1 |
| 19 | 0509885 | Nut..... | 1 |
| 20 | 0509963 | Gas spring axle..... | 1 |
| 21 | 0509964 | Wheel axle..... | 1 |

Line Laser (P/N 0509944)

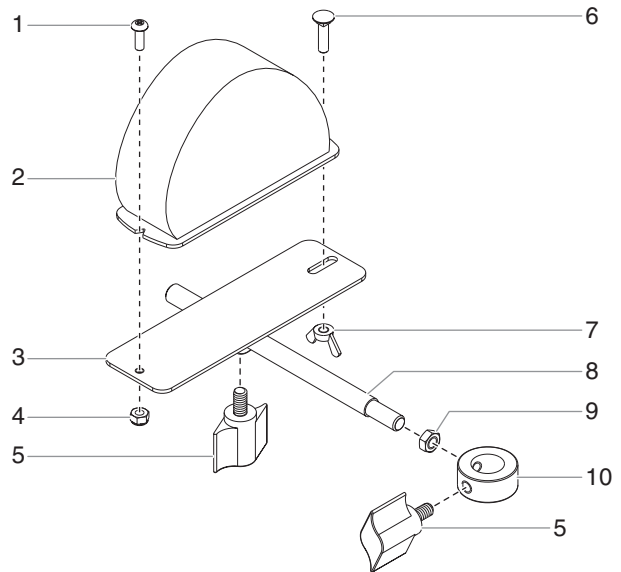

| <u>Item</u> | <u>Part #</u> | <u>Description</u> | <u>Quantity</u> |
|-------------|---------------|---------------------|-----------------|
| 1 | 0509218 | Screw..... | 1 |
| 2 | 0509878 | Laser light..... | 1 |
| 3 | 0509879 | Bracket..... | 1 |
| 4 | 0509880 | Lock nut..... | 1 |
| 5 | 0509881 | Knob..... | 2 |
| 6 | 0509882 | Carriage screw..... | 1 |
| 7 | 0509883 | Wing nut..... | 1 |
| 8 | 0509884 | Adjustment rod..... | 1 |
| 9 | 0509885 | Jam nut..... | 1 |
| 10 | 0509886 | Clamp collar..... | 1 |

Notes

Limited Warranty

SprayTECH, a division of Wagner Spray Tech Corporation ("SprayTECH"), warrants that at the time of delivery to the original purchaser for use ("End User"), the equipment covered by this warranty is free from defects in material and workmanship. With the exception of any special, limited, or extended warranty published by SprayTECH, SprayTECH's obligation under this warranty is limited to replacing or repairing without charge those parts which, to SprayTECH's reasonable satisfaction, are shown to be defective within twelve (12) months after sale to the End User. This warranty applies only when the unit is installed and operated in accordance with the recommendations and instructions of SprayTECH.

This warranty does not apply in the case of damage or wear caused by abrasion, corrosion or misuse, negligence, accident, faulty installation, substitution of non- SprayTECH component parts, or tampering with the unit in a manner to impair normal operation.

Defective parts are to be returned to an authorized SprayTECH sales/service outlet. All transportation charges, including return to the factory, if necessary, are to be borne and prepaid by the End User. Repaired or replaced equipment will be returned to the End User transportation prepaid.

THERE IS NO OTHER EXPRESS WARRANTY. SPRAYTECH HEREBY DISCLAIMS ANY AND ALL IMPLIED WARRANTIES INCLUDING, BUT NOT LIMITED TO, THOSE OF MERCHANTABILITY AND FITNESS FOR A PARTICULAR PURPOSE, TO THE EXTENT PERMITTED BY LAW. THE DURATION OF ANY IMPLIED WARRANTIES WHICH CANNOT BE DISCLAIMED IS LIMITED TO THE TIME PERIOD SPECIFIED IN THE EXPRESS WARRANTY. IN NO CASE SHALL SPRAYTECH LIABILITY EXCEED THE AMOUNT OF THE PURCHASE PRICE. LIABILITY FOR CONSEQUENTIAL, INCIDENTAL OR SPECIAL DAMAGES UNDER ANY AND ALL WARRANTIES IS EXCLUDED TO THE EXTENT PERMITTED BY LAW.

SPRAYTECH MAKES NO WARRANTY AND DISCLAIMS ALL IMPLIED WARRANTIES OF MERCHANTABILITY AND FITNESS FOR A PARTICULAR PURPOSE WITH RESPECT TO ACCESSORIES, EQUIPMENT, MATERIALS OR COMPONENTS SOLD BUT NOT MANUFACTURED BY SPRAYTECH. THOSE ITEMS SOLD, BUT NOT MANUFACTURED BY SPRAYTECH (SUCH AS GAS ENGINES, SWITCHES, HOSES, ETC.) ARE SUBJECT TO THE WARRANTY, IF ANY, OF THEIR MANUFACTURER. SPRAYTECH WILL PROVIDE THE PURCHASER WITH REASONABLE ASSISTANCE IN MAKING ANY CLAIM FOR BREACH OF THESE WARRANTIES.

Patents

These products are covered by one or more of the following U.S. patents:

| | | | | | | |
|-----------|-----------|-----------|-----------|-----------|-----------|-----------|
| 6,031,352 | 5,848,566 | 5,769,321 | 5,725,364 | 5,671,656 | 5,435,697 | 5,228,842 |
| 5,346,037 | 5,252,210 | 5,217,238 | 5,192,425 | 4,908,538 | 4,768,929 | 4,744,571 |
| D384,676 | 6,179,222 | 5,934,883 | 4,723,892 | | | |

Material Safety Data Sheets (MSDS) are available on SprayTECH's website or by calling Technical Service.

SprayTECH



1770 Fernbrook Lane
Minneapolis, MN 55447

Technical Assistance: 1-800-292-4637

Order Entry: 1-800-443-4500

Fax: 1-800-525-9501

www.spraytechinc.com