

# **GPX 220**

## **Gas Piston Pump**

**Owner's Manual**

**Do not use this equipment before reading this manual!**



**Model Number: 0509023 - Complete**

**SprayTECH**<sup>®</sup>  
**THE DEPENDABLE CHOICE™**

**NOTE: This manual contains important warnings and instructions. Please read and retain for reference.**

**SprayTECH**  
1770 Fernbrook Lane  
Minneapolis, MN 55447

Technical Assistance: 1-800-292-4637

Order Entry: 1-800-443-4500

Fax: 1-800-525-9501

[www.spraytechinc.com](http://www.spraytechinc.com)



# Important Safety Information • Read all safety information before operating the equipment. Save these instructions.



This symbol indicates a hazardous situation, which, if not avoided could result in death or serious injury.



To reduce the risks of fire or explosion, electrical shock and the injury to persons, read and understand all instructions included in this manual. Be familiar with the controls and proper usage of the equipment.

## HAZARD: INJECTION INJURY

A high pressure paint stream produced by this equipment can pierce the skin and underlying tissues, leading to serious injury and possible amputation. See a physician immediately.



**DO NOT TREAT AN INJECTION INJURY AS A SIMPLE CUT! Injection can lead to amputation. See a physician immediately.**

The maximum operating range of the sprayer is 3300 PSI / 22.8 MPa fluid pressure.

### PREVENTION:

- NEVER aim the gun at any part of the body.
- Do not aim the gun at, or spray any person or animal.
- NEVER allow any part of the body to touch the fluid stream. DO NOT allow body to touch a leak in the fluid hose.
- NEVER put your hand in front of the gun. Gloves will not provide protection against an injection injury.
- ALWAYS lock the gun trigger, shut the pump off, and release all pressure before servicing, cleaning the tip or guard, changing tip, or leaving unattended. Pressure will not be released by turning off the motor. The PRIME/SPRAY valve or pressure bleed valve must be turned to their appropriate positions to relieve system pressure. Refer to the PRESSURE RELIEF PROCEDURE described in this manual.
- ALWAYS keep the tip guard in place while spraying. The tip guard provides some protection but is mainly a warning device.
- ALWAYS remove the spray tip before flushing or cleaning the system.
- Paint hose can develop leaks from wear, kinking and abuse. A leak can inject material into the skin. Inspect the hose before each use. Do not use hose to lift or pull equipment.
- NEVER use a spray gun without a working trigger lock and trigger guard in place.
- All accessories must be rated at or above 3300 PSI / 22.8 MPa. This includes spray tips, guns, extensions, and hose.
- Do not leave the unit energized or under pressure while unattended. When the unit is not in use, turn off the unit and relieve the pressure in accordance with the PRESSURE RELIEF PROCEDURE described in this manual.
- Verify that all connections are secure before operating the unit. Unsecured parts may eject at great force or leak a high pressure fluid stream causing severe injury.
- Always engage the trigger lock when not spraying. Verify the trigger lock is functioning properly.

### NOTE TO PHYSICIAN:

Injection into the skin is a traumatic injury. It is important to treat the injury as soon as possible. DO NOT delay treatment to research toxicity. Toxicity is a concern with some coatings injected directly into the blood stream. Consultation with a plastic surgeon or reconstructive hand surgeon may be advisable.

## HAZARD: HAZARDOUS VAPORS

Paints, solvents, insecticides, and other materials can be harmful if inhaled or come in contact with the body. Vapors can cause severe nausea, fainting, or poisoning.



### PREVENTION:

- Use a respirator or mask if vapors can be inhaled. Read all instructions supplied with the mask to be sure it will provide the necessary protection.
- Wear protective eyewear.
- Wear protective clothing as required by coating manufacturer.



## HAZARD: EXPLOSION OR FIRE

Solvent and paint fumes can explode or ignite. Property damage and/or severe injury can occur.



### PREVENTION:

- Provide extensive exhaust and fresh air introduction to keep the air within the spray area free from accumulation of flammable vapors. Solvent and paint fumes can explode or ignite.
- Do not spray in a confined area.
- Avoid all ignition sources such as static electric sparks, open flames, pilot lights, electrical appliances, and hot objects. Connecting or disconnecting power cords or working light switches can make sparks. Paint or solvent flowing through the equipment is able to result in static electricity.
- Do not smoke in spray area.
- Fire extinguisher must be present and in good working order.
- Place pump at least 25 feet (7.62 meters) from the spray object in a well ventilated area (add more hose if necessary). Flammable vapors are often heavier than air. Floor area must be extremely well ventilated. The pump contains arcing parts that emit sparks and can ignite vapors.
- The equipment and objects in and around the spray area must be properly grounded to prevent static sparks.
- Keep area clean and free of paint or solvent containers, rags and other flammable materials.
- Use only conductive or grounded high pressure fluid hose. Gun must be grounded through hose connections.
- For electric units — power cord must be connected to a grounded circuit.
- Always flush unit into a separate metal container, at low pump pressure, with spray tip removed. Hold gun firmly against side of container to ground container and prevent static sparks.
- Follow the material and solvent manufacturer's warnings and instructions. Know the contents of the paints and solvents being sprayed. Read all Material Safety Data Sheets (MSDS) and container labels provided with the paints and solvents. Follow the paint and solvent manufacturer's safety instructions.
- Do not spray or clean with liquids having a flash point of less than 21°C (70°F). Flashpoint is the temperature that a fluid can produce enough vapors to ignite.
- Plastic can cause static sparks. Never hang plastic to enclose a spray area. Do not use plastic drop cloths when spraying flammable materials.
- Use lowest possible pressure to flush equipment.
- Do not spray onto pump assembly.





# Important Safety Information • Read all safety information before operating the equipment. Save these instructions.

## HAZARD: EXPLOSION HAZARD DUE TO INCOMPATIBLE MATERIALS



Will cause property damage or severe injury.

### PREVENTION:

- Do not use materials containing bleach or chlorine.
- Do not use halogenated hydrocarbon solvents such as bleach, mildewcide, methylene chloride and 1,1,1 - trichloroethane. They are not compatible with aluminum.
- Contact your coating supplier about the compatibility of material with aluminum.

## HAZARD: GENERAL

Can cause severe injury or property damage.

- Read all instructions and safety precautions before operating equipment.
- Follow all appropriate local, state, and national codes governing ventilation, fire prevention, and operation.
- The United States Government Safety Standards have been adopted under the Occupational Safety and Health Act (OSHA). These standards, particularly part 1910 of the General Standards and part 1926 of the Construction Standards should be consulted.
- Use only manufacturer authorized parts. User assumes all risks and liabilities when using parts that do not meet the minimum specifications and safety requirements of the pump manufacturer.
- All hoses, fittings, and filter parts must be secured before operating spray pump. Unsecured parts can eject at great force or leak a high pressure fluid stream causing severe injury.
- Before each use, check all hoses for cuts, leaks, abrasion or bulging of cover. Check for damage or movement of couplings. Immediately replace the hose if any of these conditions exist. Never repair a paint hose. Replace it with another grounded high-pressure hose.
- Do not kink or over-bend the hose. Airless hose can develop leaks from wear, kinking and abuse. A leak can inject material into the skin.
- Do not expose the hose to temperatures or pressures in excess of those specified by manufacturer.
- Do not spray outdoors on windy days.
- Wear clothing to keep paint off skin and hair.
- Do not operate or spray near children. Keep children away from the equipment at all times.
- Do not overreach or stand on an unstable support. Keep effective footing and balance at all times.
- Use lowest possible pressure to flush equipment.
- Stay alert and watch what you are doing.
- Do not operate the unit when fatigued or under the influence of drugs or alcohol.
- For electric units — Always unplug cord from outlet before working on equipment.
- Do not use the hose as a strength member to pull or lift the equipment.
- Do not lift by cart handle when loading or unloading.

## Gasoline Engine Safety



The engine exhaust from this unit contains chemicals known to the State of California to cause cancer, birth defects, or other reproductive harm.

- Gas engines are designed to give safe and dependable service if operated according to instructions. Read and understand the engine Owner's Manual before operating the engine. Failure to do so could result in personal injury or equipment damage.
- To prevent fire hazards and to provide adequate ventilation, keep the engine at least 1 meter (3 feet) away from buildings and other equipment during operation. Do not place flammable objects close to the engine.
- Children and pets must be kept away from the area of operation due to a possibility of burns from hot engine components or injury from any equipment the engine may be used to operate.
- Know how to stop the engine quickly, and understand the operation of all controls. Never permit anyone to operate the engine without proper instructions.
- Gasoline is extremely flammable and is explosive under certain conditions.
- Refuel in a well-ventilated area with the engine stopped. Do not smoke or allow flames or sparks in the refueling area or where gasoline is stored.
- Do not overfill the fuel tank. After refueling, make sure the tank cap is closed properly and securely.
- Be careful not to spill fuel when refueling. Fuel vapor or spilled fuel may ignite. If any fuel is spilled, make sure the area is dry before starting the engine.
- Never run the engine in an enclosed or confined area. Exhaust contains poisonous carbon monoxide gas; exposure may cause loss of consciousness and may lead to death.
- The muffler becomes very hot during operation and remains hot for a while after stopping the engine. Be careful not to touch the muffler while it is hot. To avoid severe burns or fire hazards, let the engine cool before transporting it or storing it indoors.
- Never ship/transport unit with gasoline in the tank.

## Specifications

Gallons per minute (GPM) .....	2.2 (8.33 LPM)
Maximum tip size .....	one gun = 0.049"
	two guns = 0.033"
	three guns = 0.026"
	four guns = 0.022"
Maximum pressure .....	3300 PSI (22.8 MPa)
Power .....	7.0 HP gas engine
Weight .....	164 lbs. (74.4 kg)
Maximum hose length .....	300' (91.4 m)

# Table of Contents

- Safety Precautions.....2-3
  - Français .....18
  - Español.....20
- Specifications .....3
- General Description .....4
- Operation .....4
  - Setup .....4
  - Preparing to Paint.....5
  - Painting.....5
  - Pressure Relief Procedure .....6
- Spraying.....6-7
  - Spraying Technique .....6
  - Practice.....7
- Cleanup .....7
- Maintenance.....8
  - General Repair and Service Notes.....8
  - Maintaining the Engine .....8
  - Replacing the Filter.....9
  - Replacing the PRIME/SPRAY Valve.....9
  - Replacing the Potentiometer .....9
  - Replacing the Sprayer ON/OFF Switch.....10
  - Replacing the Transducer.....10
  - Replacing the Electronic Pressure Control (EPC) Assembly.....11
  - Replacing the Slider Assembly and Slider Housing.....11
  - Replacing the Gears.....12
  - Servicing the Clutch Assembly .....12
  - Servicing the Fluid Section.....15
- Troubleshooting .....17
- Parts Listings.....22
  - Main Assembly.....22
  - Drive Assembly .....23
  - Fluid Section Assembly .....24
  - Cart Assembly.....25
  - Filter Assembly .....25
  - PRIME/SPRAY Assembly .....26
  - Electrical Schematic .....26
  - Labels .....27
  - Accessories .....27
- Limited Warranty .....28

## General Description

This airless sprayer is a precision power tool used for spraying many types of materials. Read and follow this instruction manual carefully for proper operating instructions, maintenance, and safety information.

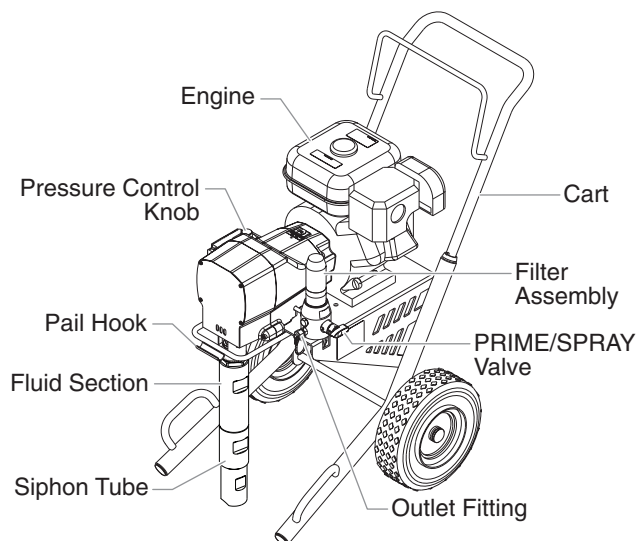

## Operation



This equipment produces a fluid stream at extremely high pressure. Read and understand the warnings in the Safety Precautions section at the front of this manual before operating this equipment.

## Setup

Perform the following procedure before starting the engine of a gas-powered sprayer.

1. Ensure that the siphon tube and the return hose are attached and secure.
2. Attach the supplied grounding cable to a grounded object.
3. Using a wrench, attach a minimum of 50' of 3/8" nylon airless spray hose to the 3/8" outlet fitting on the filter assembly. Tighten securely.

**NOTE: Use 3/8" spray hose for maximum performance, minimum pressure drop, and minimum pressure fluctuation.**

4. Attach an airless spray gun to the spray hose. Using two wrenches (one on the gun and one on the hose), tighten securely.

**NOTE: Do not attach the tip to the spray gun yet. Remove the tip if it is already attached.**



Make sure all airless hoses and spray guns are electrically grounded and rated at or above the maximum operating pressure range of the airless sprayer.

5. Turn the pressure control knob fully counterclockwise to its lowest pressure setting.
6. Make sure the sprayer ON/OFF switch is in the OFF position.
7. Fill the fluid section oil cup with approximately one tablespoon of separating oil (P/N 0279920).

**IMPORTANT: Never operate unit for more than ten seconds without fluid. Operating this unit without fluid will cause unnecessary wear to the packings.**

8. Check the engine oil level. The gasoline engine oil level is determined by the manufacturer. Refer to the engine manufacturer's service manual (supplied).
9. Close the fuel shut-off lever and fill the gas tank with gasoline. Use only high quality, unleaded gasoline.

## Preparing a New Sprayer

If this unit is new, it is shipped with test fluid in the fluid section to prevent corrosion during shipment and storage. This fluid must be thoroughly cleaned out of the system with mineral spirits before you begin spraying.

**IMPORTANT: Always keep the trigger lock on the spray gun in the locked position while preparing the system.**

1. Place the siphon tube into a container of mineral spirits that has a flash point of 60°C (140°F) or above.
2. Place the return hose into a metal waste container.
3. Turn the pressure control knob fully counterclockwise to its lowest pressure setting.
4. Move the PRIME/SPRAY valve to the PRIME position.
5. Move the engine ON/OFF switch to the ON position.
6. Start the engine:
  - a. Open the fuel valve lever.
  - b. Move the throttle lever away from the gas tank.
  - c. Close the engine choke lever.
  - d. Holding the frame with one hand, pull

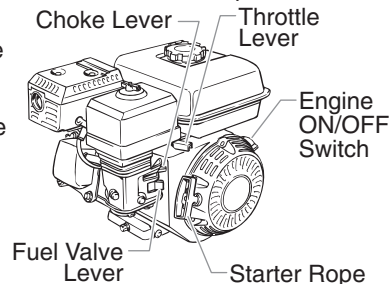



the starter rope rapidly and firmly. Continue to hold the rope as you let it return. Pull and return the rope until the engine starts.

7. Turn on the sprayer by moving the sprayer ON/OFF switch to the ON position.
8. Slowly turn the pressure control knob clockwise to increase the pressure until fluid starts to come out of the return hose. Use only enough pressure to keep the fluid coming out.
9. Allow the sprayer to run for 15–30 seconds to flush the test fluid out through the return hose and into the waste container.
10. Turn the pressure control knob fully counterclockwise to its lowest setting.
11. Turn off the sprayer by moving the sprayer ON/OFF switch to the OFF position.

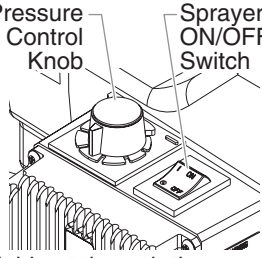

## Preparing to Paint

Before painting, it is important to make sure that the fluid in the system is compatible with the paint that is going to be used.

**NOTE: Incompatible fluids and paint may cause the valves to become stuck closed, which would require disassembly and cleaning of the sprayer's fluid section.**

**IMPORTANT: Always keep the trigger lock on the spray gun in the locked position while preparing the system.**

1. Place the siphon tube into a container of the appropriate solvent for the material being sprayed (refer to recommendations of the material manufacturer). An example of the appropriate solvent is water for latex paint.
2. Place the return hose into a metal waste container.
3. Turn the pressure control knob fully counterclockwise to its lowest pressure setting.
4. Move the PRIME/SPRAY valve to the PRIME position.

**NOTE: Hold the return hose in the waste container when moving the PRIME/SPRAY valve to PRIME in case the sprayer is pressurized.**

5. Move the engine ON/OFF switch to the ON position.
  6. Start the engine:
    - a. Open the fuel valve lever.
    - b. Move the throttle lever away from the gas tank.
    - c. Close the engine choke lever.
    - d. Holding the frame with one hand, pull the starter rope rapidly and firmly. Continue to hold the rope as you let it return. Pull and return the rope until the engine starts.
  7. Turn on the sprayer by moving the sprayer ON/OFF switch to the ON position.
  8. Slowly turn the pressure control knob clockwise to increase the pressure until fluid starts to come out of the return hose. Use only enough pressure to keep the fluid coming out.
  9. Allow the sprayer to run until 15–30 seconds to flush the old solvent out through the return hose and into the metal waste container.
  10. Turn the pressure control knob fully counterclockwise to its lowest setting.
  11. Turn off the sprayer by moving the sprayer ON/OFF switch to the OFF position.
- NOTE: Make sure that the spray gun does not have a tip or tip guard installed.**
12. Move the PRIME/SPRAY valve to the SPRAY position.
  13. Turn on the sprayer.
  14. Turn the pressure control knob slowly clockwise to increase pressure.
  15. Unlock the gun by turning the gun trigger lock to the unlocked position.



**Ground the gun by holding it against the edge of the metal container while flushing. Failure to do so may lead to a static electric discharge, which may cause a fire.**

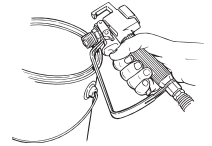

16. Trigger the gun into the metal waste container until the old solvent is gone and fresh solvent is coming out of the gun.
17. Lock the gun by turning the gun trigger lock to the locked position.
18. Set down the gun and increase the pressure by turning the pressure control knob slowly clockwise to its highest setting.
19. Check the entire system for leaks. If leaks occur, turn the sprayer off and follow the "Pressure Relief Procedure" in this manual before tightening any fittings or hoses.
20. Follow the "Pressure Relief Procedure" in this manual before changing from solvent to paint.



**Be sure to follow the pressure relief procedure when shutting the unit down for any purpose, including servicing or adjusting any part of the spray system, changing or cleaning spray tips, or preparing for cleanup.**

## Painting

1. Place the siphon tube into a container of paint.
2. Place the return hose into a metal waste container.
3. Turn the pressure control knob fully counterclockwise to its lowest pressure setting.
4. Move the PRIME/SPRAY valve to the PRIME position.
5. Move the engine ON/OFF switch to the ON position.
6. Start the engine:
  - a. Open the fuel valve lever.
  - b. Move the throttle lever away from the gas tank.
  - c. Close the engine choke lever.
  - d. Holding the frame with one hand, pull the starter rope rapidly and firmly. Continue to hold the rope as you let it return. Pull and return the rope until the engine starts.

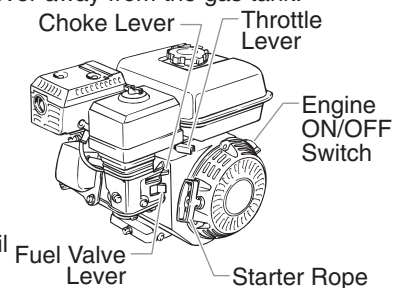

7. Turn on the sprayer by moving the sprayer ON/OFF switch to the ON position.
8. Slowly turn the pressure control knob clockwise to increase the pressure until fluid starts to come out of the return hose. Use only enough pressure to keep the fluid coming out.
9. Allow the sprayer to run until 15–30 seconds to flush the old solvent out through the return hose into the metal waste container.
10. Turn the pressure control knob fully counterclockwise to its lowest setting.
11. Turn off the sprayer by moving the sprayer ON/OFF switch to the OFF position.
12. Remove the return hose from the waste container and place it in its operating position above the container of paint.
13. Move the PRIME/SPRAY valve to the SPRAY position.
14. Turn on the sprayer.
15. Turn the pressure control knob slowly clockwise to increase pressure.
16. Unlock the gun by turning the gun trigger lock to the unlocked position.

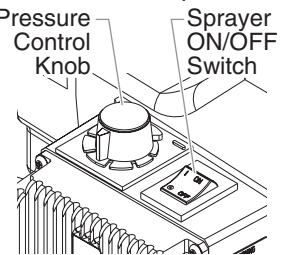



**Ground the gun by holding it against the edge of the metal container while flushing. Failure to do so may lead to a static electric discharge, which may cause a fire.**

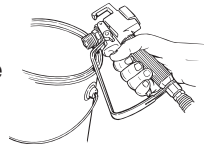

17. Trigger the gun into the metal waste container until all air and solvent is flushed from the spray hose and paint is flowing freely from the gun.
18. Lock the gun by turning the gun trigger lock to the locked position.
19. Turn the pressure control knob fully counterclockwise to its lowest setting.
20. Turn off the sprayer.
21. Attach tip guard and tip to the gun as instructed by the tip guard or tip manuals.



**POSSIBLE INJECTION HAZARD. Do not spray without the tip guard in place. Never trigger the gun unless the tip is in either the spray or the unclog position. Always engage the gun trigger lock before removing, replacing or cleaning tip.**

22. Turn on the sprayer.
23. Increase the pressure by turning the pressure control knob slowly clockwise and test the spray pattern on a piece of cardboard. Adjust the pressure control knob until the spray from the gun is completely atomized. Try to keep the pressure control knob at the lowest setting that maintains good atomization.

**NOTE: Turning the pressure up higher than needed to atomize the paint will cause premature tip wear and additional overspray.**

## Pressure Relief Procedure



**Be sure to follow the pressure relief procedure when shutting the unit down for any purpose, including servicing or adjusting any part of the spray system, changing or cleaning spray tips, or preparing for cleanup.**

1. Lock the gun by turning the gun trigger lock to the locked position.
2. Turn off the sprayer by moving the sprayer ON/OFF switch to the OFF position.
3. Turn off the engine by moving the engine ON/OFF switch to the OFF position.
4. Turn the pressure control knob counterclockwise to its lowest setting.
5. Unlock the gun by turning the gun trigger lock to the unlocked position.
4. Hold the metal part of the gun firmly to the side of a metal container to ground the gun and avoid a build up of static electricity.
5. Trigger the gun to remove any pressure that may still be in the hose.
6. Lock the gun by turning the gun trigger lock to the locked position.
7. Move the PRIME/SPRAY valve to the PRIME position.

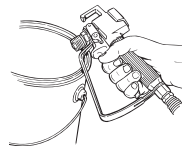

## Spraying

**NOTE: When spraying block filler, mastics or high solid coating, remove the gun filter and high pressure filter screens.**

### Spraying Technique

The key to a good paint job is an even coating over the entire surface. This is done by using even strokes. Keep your arm moving at a constant speed and keep the spray gun at a constant distance from the surface. The best spraying distance is 10 to 12 inches between the spray tip and the surface.

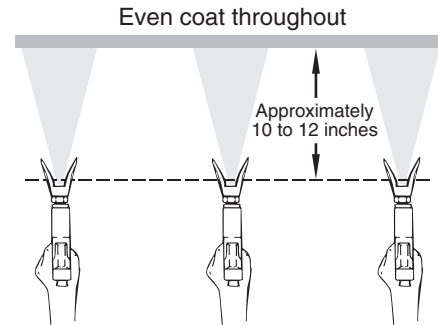

Keep the spray gun at right angles to the surface. This means moving your entire arm back and forth rather than just flexing your wrist.

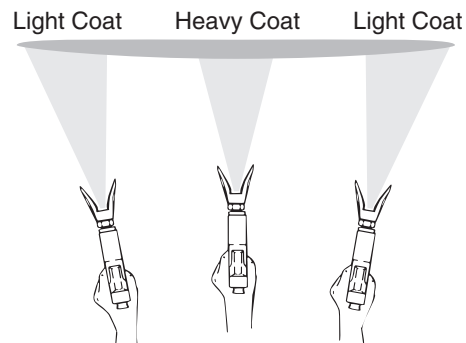

Do not flex wrist while spraying.

Keep the spray gun perpendicular to the surface, otherwise one end of the pattern will be thicker than the other.

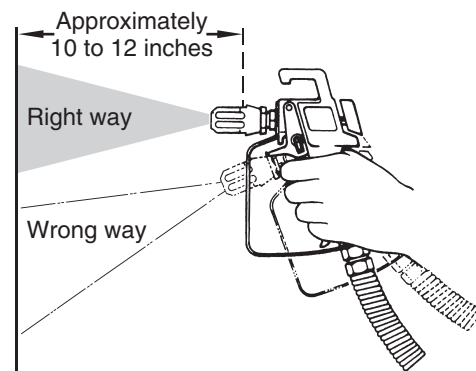

The spray gun should be triggered by turning it on and off with each stroke. This will save paint and avoid paint buildup at the end of the stroke. Do not trigger the gun during the middle of a stroke. This will result in an uneven spray and splotchy coverage.

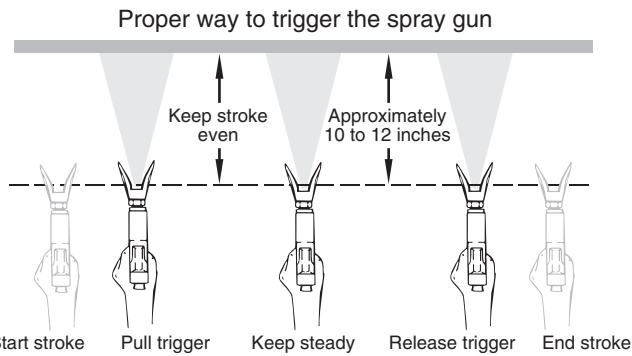

Overlap each stroke by about 30%. This will ensure an even coating.

When you stop painting, lock the gun trigger lock, turn the pressure control knob counterclockwise to its lowest setting and set the PRIME/SPRAY valve to PRIME. Turn the motor switch to OFF and unplug the sprayer.

## Practice

1. Be sure that the paint hose is free of kinks and clear of objects with sharp cutting edges.
2. Turn the pressure control knob counterclockwise to its lowest setting.
3. Move the PRIME/SPRAY valve to the SPRAY position.
4. Turn the pressure control knob clockwise to its highest setting. The paint hose should stiffen as paint begins to flow through it.
5. Unlock the gun trigger lock.
6. Trigger the spray gun to bleed air out of the hose.
7. When paint reaches the spray tip, spray a test area to check the spray pattern.
8. Use the lowest pressure setting necessary to get a good spray pattern. If the pressure is set too high, the spray pattern will be too light. If the pressure is set too low, tailing will appear or the paint will spatter out in gobs rather than in a fine spray.

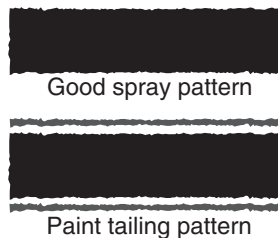

## Cleanup



**Special cleanup instructions for use with flammable solvents:**

- Always flush spray gun preferably outside and at least one hose length from spray pump.
- If collecting flushed solvents in a one gallon metal container, place it into an empty five gallon container, then flush solvents.
- Area must be free of flammable vapors.
- Follow all cleanup instructions.

**IMPORTANT: The sprayer, hose, and gun should be cleaned thoroughly after daily use. Failure to do so permits material to build up, seriously affecting the performance of the unit.**



**Always spray at minimum pressure with the gun nozzle tip removed when using mineral spirits or any other solvent to clean the sprayer, hose, or gun. Static electricity buildup may result in a fire or explosion in the presence of flammable vapors.**

1. Follow the "Pressure Relief Procedure" found in the Operation section of this manual.
2. Remove the gun tip and tip guard and clean with a brush

using the appropriate solvent.

3. Place the siphon tube into a container of the appropriate solvent (refer to recommendations of the material manufacturer). An example of the appropriate solvent is water for latex paint.
4. Place the return hose into a metal waste container.
5. Move the PRIME/SPRAY valve to its PRIME position.

**NOTE: Hold the return hose in the waste container when moving the PRIME/SPRAY valve to PRIME in case the sprayer is pressurized.**

6. Move the engine ON/OFF switch to the ON position and start the engine.
7. Turn on the sprayer by moving the sprayer ON/OFF switch to the ON position.
8. Slowly turn the pressure control knob clockwise to increase the pressure until fluid starts to come out of the return hose.
9. Allow the solvent to circulate through the sprayer and flush the paint out of the return hose into the metal waste container.
10. Turn the pressure control knob fully counterclockwise to its lowest setting.
11. Turn off the sprayer by moving the ON/OFF switch to the OFF position.
12. Move the PRIME/SPRAY valve to its SPRAY position.
13. Turn on the sprayer.
14. Turn the pressure control knob slowly clockwise to increase pressure.

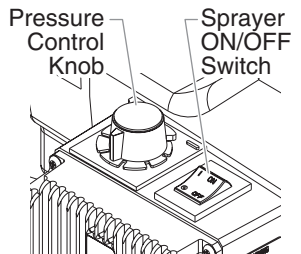

**Ground the gun by holding it against the edge of the metal container while flushing. Failure to do so may lead to a static electric discharge, which may cause a fire.**

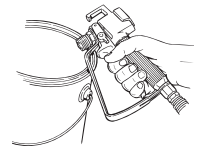

15. Trigger the gun into the metal waste container until the paint is flushed out of the hose and solvent is coming out of the gun.
16. Continue to trigger the spray gun into the waste container until the solvent coming out of the gun is clean.

**NOTE: For long-term or cold weather storage, pump mineral spirits through the entire system.**

17. Follow the "Pressure Relief Procedure" found in the Operation section of this manual.
18. Store the sprayer in a clean, dry area.

**IMPORTANT: Do not store the sprayer under pressure.**

## Cleaning the Spray Tip

1. Flush the gun with solvent immediately after the work is completed.
2. Oil the sliding pins to prevent them from seizing up.

Should the spray tip become clogged, reverse the spray tip with the lever and pull the trigger. Once the obstruction comes out of the spray tip, release the trigger, reverse the spray tip back to the spray pattern setting, and resume spraying.



**Do not attempt to clean the tip with your finger. Do not use a needle or other sharp pointed instrument to clean the tip. The hard tungsten carbide is brittle and can be chipped.**

# Maintenance



Before proceeding, follow the Pressure Relief Procedure outlined previously in this manual. Additionally, follow all other warnings to reduce the risk of an injection injury, injury from moving parts, or electric shock.

**NOTE:** All Honda engine work should be performed by a Honda authorized service center.

## General Repair and Service Notes

The following tools are needed when repairing this sprayer:

Phillips screwdriver	3/8" hex wrench
needle-nose pliers	5/16" hex wrench
adjustable wrench	1/4" hex wrench
rubber mallet	3/16" hex wrench
flat-blade screwdriver	1/8" hex wrench
1/2" open-end wrench	7/8" open-end wrench

1. Before repairing any part of the sprayer, read the instructions carefully, including all warnings.

**IMPORTANT:** Never pull on a wire to disconnect it. Pulling on a wire could loosen the connector from the wire.

2. Test your repair before regular operation of the sprayer to be sure that the problem is corrected. If the sprayer does not operate properly, review the repair procedure to determine if everything was done correctly. Refer to the Troubleshooting section to help identify other possible problems.
3. Make certain that the service area is well ventilated in case solvents are used during cleaning. Always wear protective eyewear while servicing. Additional protective equipment may be required depending on the type of cleaning solvent. Always contact the supplier of solvents for recommendations.
4. If you have any further questions concerning your SprayTECH airless sprayer, call SprayTECH:

Technical Service.....1-800-292-4637  
 Fax .....1-800-525-9501

# Maintaining the Engine



When transporting a sprayer with a gas engine, make sure the fuel is shut off.

**NOTE:** For detailed engine specifications and maintenance, refer to the separate engine manual supplied with this sprayer.

## Important Facts Concerning this Sprayer

This gas-powered sprayer contains a clutch that engages when the sprayer is pumping. The sprayer's pressure control system engages and disengages the clutch to control pressure. To prevent unnecessary wear to the clutch, it is advisable to adjust the engine speed and pressure setting to limit the amount of times the clutch engages and disengages. To reduce clutch wear, refer to the following examples.

### Example:

Operating one gun with a .019 tip — reduce the engine speed by adjusting the throttle to a low or medium setting and increase pressure only until the heavy ends of the spray pattern have been eliminated.

### Example:

Operating one gun with .023 tip — increase engine speed to a higher setting and increase pressure until the heavy ends of the spray pattern have been eliminated.

### Example:

Spraying light-bodied materials at low pressure — to reduce surging at the gun and to decrease clutch wear, reduce the engine speed to idle and reduce pressure until the desired spray pattern is achieved.

## Routine Engine Maintenance

### Daily

- Check and fill the gas tank.
- After the first 20 hours of operation, drain the oil and refill with clean oil. Check the engine oil level and fill as necessary.

### Weekly

- Remove the cover of the air filter and clean the element. Replace the element if necessary. If operating in an unusually dusty environment, check the filter daily and replace if necessary. (Replacement elements can be purchased from your local SprayTECH dealer.)
- After each 50 hours of operation: Change the engine oil.

### Spark Plug

- Use only a (NKG) BP6ES plug.
- Gap the plug 0.025" – 0.030" (0.7 – 0.8 mm).
- Make sure to use a spark plug wrench when installing and removing the plug.



## Replacing the Filter

1. Loosen and remove the filter body by hand.
2. Remove the filter and filter support spring from the filter housing.
3. Remove the filter support spring and adapter from inside the filter.
4. Inspect the filter. Based on inspection, clean or replace the filter.
5. Inspect the filter housing o-ring. Based on inspection, clean or replace the o-ring.
6. Slide the new or cleaned filter over the adapter and filter support spring. Place the filter and filter support spring into the center of the filter housing.
7. Clean the inside of the filter body.
8. Slide the filter body over the filter and thread it into the filter housing until secure. Make sure the filter spring is in position on top of the filter.

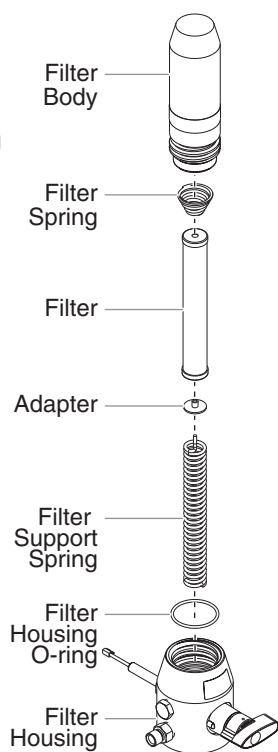

**NOTE: The filter body should be hand-tightened, but make sure it is seated fully into the filter housing.**

## Replacing the PRIME/SPRAY Valve

Perform the following procedure using PRIME/SPRAY valve replacement kit P/N 0507690.

1. Drive the groove pin out of the valve handle.
2. Remove the valve handle and the cam base.
3. Using a wrench, loosen and remove the valve housing assembly.
4. Make sure the gasket is in place and thread the new valve housing assembly into the filter housing. Tighten securely with a wrench.
5. Place the cam base over the valve housing assembly. Lubricate the cam base with grease and line up the cam with the filter block using the dowel pin.
6. Line up the hole on the valve stem with the hole in the valve handle.
7. Insert the groove pin into the valve handle and through the valve stem to secure the valve handle in position.

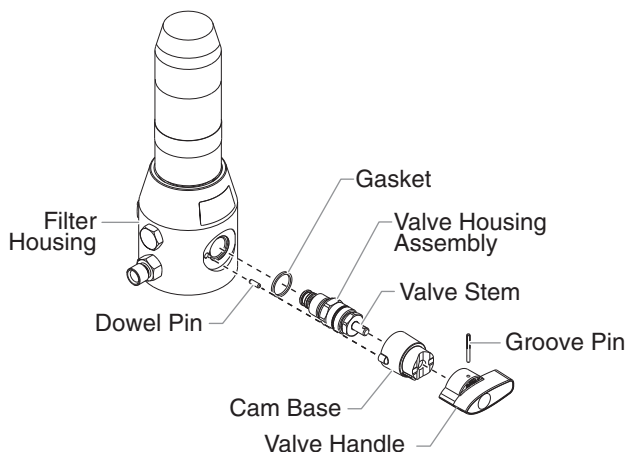

## Replacing the Potentiometer



**Electrostatic discharge (ESD) potential could cause damage to electronic pressure control. Use SprayTECH ESD wrist strap P/N 0507958 or equivalent when working on electronic pressure control.**

1. Perform the Pressure Relief Procedure.
2. Pry off the pressure control knob cap to expose the knob tension nut.
3. Turn the pressure control knob fully counterclockwise to the minimum pressure setting.
4. Using a 5/16" socket, loosen the tension nut in the center of the knob. Remove the knob.
5. Using a Phillips screwdriver, remove the four screws that secure the electronic pressure control (EPC) assembly to the EPC housing. Carefully remove the EPC assembly from the housing. Gently move the assembly away from the sprayer and allow the assembly to hang from the housing.

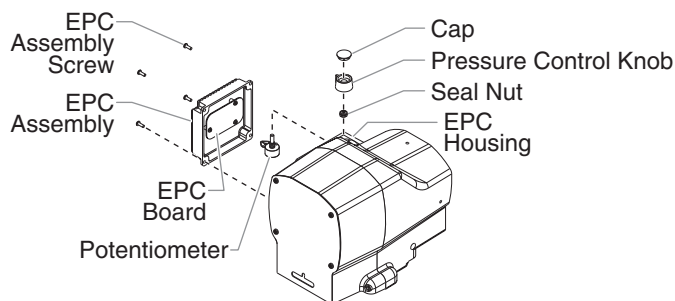

6. Hold the potentiometer inside the EPC housing while using a 1/2" thin wall socket to remove the seal nut that secures the potentiometer to the mounting plate. Remove the potentiometer from the EPC housing.
7. Carefully remove the potentiometer wires from their connection point on the EPC board.
8. Insert the stem of the new potentiometer through the hole in the mounting plate from inside the EPC housing. Position the protruding tab on the potentiometer face into the hole on the underside of the mounting plate (the wires will face the open side of the EPC housing).
9. Thread the seal nut onto the threaded portion of the stem and tighten using a 1/2" thin wall socket.

**IMPORTANT: Do not over-tighten the seal nut.**

10. Turn the potentiometer stem fully counterclockwise.
11. Place the pressure control knob on the potentiometer stem with the indicator tab resting at the "minimum pressure" tab on the mounting plate.
12. Tighten the knob tension nut using a 5/16" socket.

**IMPORTANT: Do not over-tighten the knob tension nut. Over-tightening will damage the potentiometer.**

13. Connect the potentiometer wires to the EPC board. The protruding tab on the EPC board connector will mate with the slot on the potentiometer wires connector. The connector on the end of the potentiometer wires and the connector on the EPC board will mate only one way. Do not force the connectors together.
14. Carefully place the EPC assembly over the EPC housing taking care not to pinch any wires.
15. Install the four screws that secure the EPC assembly to the EPC housing. Tighten securely.

## Replacing the Sprayer ON/OFF Switch



**Electrostatic discharge (ESD) potential could cause damage to electronic pressure control. Use SprayTECH ESD wrist strap P/N 0507958 or equivalent when working on electronic pressure control.**

1. Perform the Pressure Relief Procedure.
2. Using a Phillips screwdriver, remove the four screws that secure the electronic pressure control (EPC) assembly to the EPC housing. Carefully remove the EPC assembly from the housing. Gently move the assembly away from the sprayer and allow the assembly to hang from the housing.
3. Locate the bottom of the sprayer ON/OFF switch inside the EPC housing.

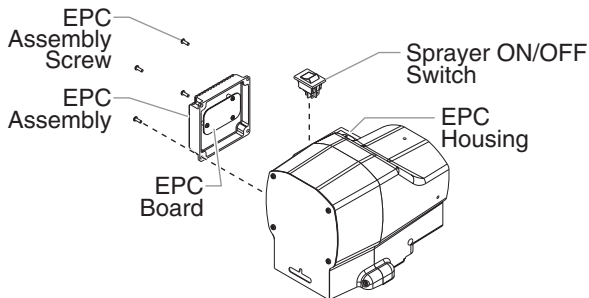

4. Disconnect the switch wires from the sprayer ON/OFF switch. Remember the locations of each of the two wires (label the wires, if necessary).
5. Depress the mounting tabs on each corner of the sprayer ON/OFF switch inside the EPC housing and remove the switch through the top of the housing.
6. Snap the new sprayer ON/OFF switch into the switch hole in the EPC housing.
7. Connect the two switch wires to the new sprayer ON/OFF switch. Make sure the wires are connected to the corresponding terminals from which they were removed (refer to the labels created earlier in this procedure or the electrical schematic in the Parts List section of this manual).
8. Carefully place the EPC assembly over the EPC housing taking care not to pinch any wires.
9. Install the four screws that secure the EPC assembly to the EPC housing. Tighten securely.

## Replacing the Transducer



**Electrostatic discharge (ESD) potential could cause damage to electronic pressure control. Use SprayTECH ESD wrist strap P/N 0507958 or equivalent when working on electronic pressure control.**

1. Perform the Pressure Relief Procedure.
2. Using a Phillips screwdriver, remove the four screws that secure the electronic pressure control (EPC) assembly to the EPC housing. Carefully remove the EPC assembly from the housing. Gently move the assembly away from the sprayer and allow the assembly to hang from the housing.
3. Locate the transducer wire in the EPC housing. This wire will be protruding from a hole in the lower left hand corner of the EPC housing. Disconnect this wire from the EPC

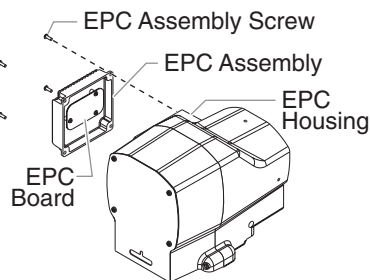

board (it has a phone jack-style connector).

4. Break off the locking tab from the phone jack-style connector at the end of the transducer wire.
5. Using a 7/8" open-end wrench, loosen and remove the fluid hose from the fitting on the bottom of the filter assembly.
6. Using a 9/16" open-end wrench, loosen and remove the return hose from the bottom of the filter assembly.
7. Using a 1/2" socket, remove the two hex screws that secure the filter assembly to the cart.
8. Lift the filter assembly off the cart so that the transducer tube moves out of the hole in the gear housing. Gently pull the transducer wire through the housing until it is fully disengaged from the hole.
9. Mount the filter assembly in a vise for easy access to the transducer.

**IMPORTANT: Do not over-tighten the vise.**

10. Using a 3/4" open-end wrench, turn the transducer nut counterclockwise to remove the transducer from the filter housing.
11. Locate the new transducer. Make sure that there is a white, PTFE o-ring on the end of the transducer that gets inserted into the filter housing.
12. Insert the transducer into the filter housing port. Rotate the transducer nut clockwise to tighten it into the filter housing. Torque the nut to 360–400 in./lbs.
13. Remove the filter assembly from the vise.

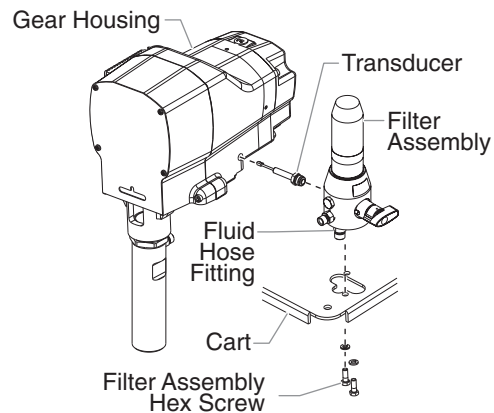

14. Insert the phone jack-style connector on the new transducer wire into the hole in the gear housing from which the old transducer wire was removed. Push the wire and connector until the connector is visible in the EPC housing.
15. Gently pull the wire into the EPC housing while moving the filter assembly to its mounting point on the cart. Guide the end of the transducer tube into the hole in the gear housing.
16. Mount the filter assembly to the cart using the two hex screws and lock washers. Torque the screws to 100–130 in./lbs.
17. Using a 7/8" open-end wrench, attach the fluid hose to the fitting on the bottom of the filter assembly. Tighten securely.
18. Using a 9/16" open-end wrench, attach the return hose to the bottom of the filter assembly. Tighten securely.
19. Plug the phone jack-style connector on the transducer wire into the socket on the EPC board from which the old connector was removed.
20. Carefully place the EPC assembly over the EPC housing taking care not to pinch any wires.
21. Install the four screws that secure the EPC assembly to the EPC housing. Tighten securely.
22. Take the sprayer to a SprayTECH Authorized Service Center for re-calibration.
23. After re-calibration, pressurize the system and check for leaks.

## Replacing the Electronic Pressure Control (EPC) Assembly



**Electrostatic discharge (ESD) potential could cause damage to electronic pressure control. Use SprayTECH ESD wrist strap P/N 0507958 or equivalent when working on electronic pressure control.**

1. Perform the Pressure Relief Procedure.
2. Using a Phillips screwdriver, remove the four screws that secure the electronic pressure control (EPC) assembly to the EPC housing. Carefully remove the EPC assembly from the housing. Gently move the assembly away from the sprayer and allow the assembly to hang from the housing.
3. Remember the locations of all the wire connections on the EPC board (refer the electrical schematic located in the Parts List section of this manual). If necessary, label all the connections so that they can be replaced in their exact location when the assembly is replaced.
4. Disconnect all the wires from the EPC board.
5. Connect all the wires to the new EPC assembly board (refer to the labels created earlier in this procedure or the electrical schematic in the Parts List section of this manual).
6. Carefully place the EPC assembly over the EPC housing taking care not to pinch any wires.
7. Install the four screws that secure the EPC assembly to the EPC housing. Tighten securely.
8. Take the sprayer to a SprayTECH Authorized Service Center for re-calibration.

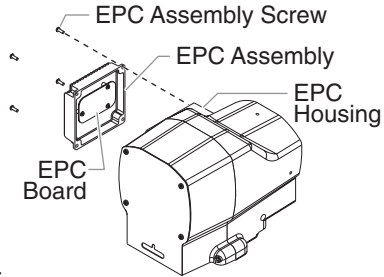

## Replacing the Slider Assembly and Slider Housing

1. Start the engine (refer to the procedures in the Operation section of this manual). Turn the pressure control knob clockwise to its maximum pressure setting.
2. Toggle the sprayer ON/OFF switch between the ON and OFF positions in short bursts until the slider assembly stops in a position where the fluid section connecting pin and retaining ring are visible through the slot in the slider housing.
3. Turn off the engine and perform the Pressure Relief Procedure.
4. Using a Phillips screwdriver, remove the four front cover screws. Remove the front cover.
5. Slide the retaining ring up on the slider assembly to expose the connecting pin.
6. Push the connecting pin forward through the slider assembly and piston. The connecting pin will fall out from the rear window of the slider housing

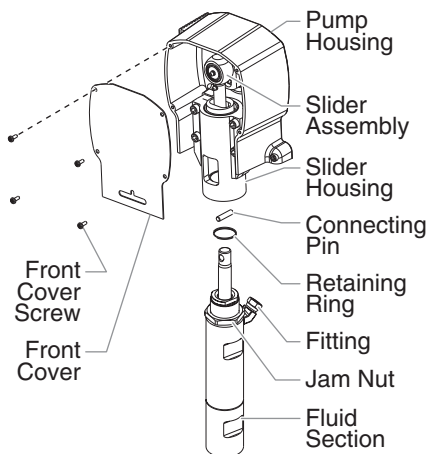

where it can be retrieved.

7. Using a 7/8" open-end wrench, loosen and remove the fluid hose from the fitting on the back of the fluid section.
8. Using a 21/4" wrench, loosen the fluid section jam nut. Turn the fluid section counterclockwise by until it disengages from the slider housing.
9. Using a 5/16" hex wrench, remove the four socket screws and lock washers that secure the slider housing to the pump housing.
10. Remove the slider housing and slider assembly by pulling it straight out from the pump housing. The slider housing assembly will disengage from the pump housing dowel pins and the connecting rod will disengage from the crankshaft.
11. Remove the slider assembly from the slider housing by grasping the bearing end of the connecting rod and lifting it straight out from the slider housing.
12. Check the parts for wear.
  - a. If the slider housing bushing is scored or out of round it should be replaced.
  - b. If the slider assembly is scored or the connection between the connecting rod and slider assembly exhibits movement other than pivoting movement, the slider assembly should be replaced. The slider assembly also should be replaced if the connecting rod bearing shows signs of wear.
  - c. Any parts that will be reused should be cleaned thoroughly, including the connecting rod. Also, clean the crankshaft pin that the connecting rod bearing rides on.
  - d. If a new slider assembly will be used, remove the retaining ring from the bottom of the old slider assembly and slide it onto the new assembly so that it rests above the connecting pin hole.
13. Lubricate the inside diameter of the slider housing and the outside diameter of the slider assembly with oil. Fill the slider cup with Lubriplate 3000W grease (the slider cup is the area on the slider assembly where the connecting rod and slider housing join and pivot).
14. Insert the slider assembly into the bushing end of the slider housing.

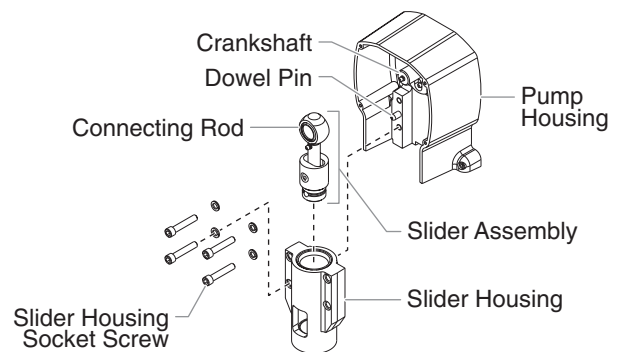

15. Hold the assembly up to the pump housing, lining up the connecting rod with the crankshaft pin and the pump housing dowel pins with their mating holes on the slider housing. Slide the assembly onto the crankshaft pin and pump housing dowel pins until the slider housing bottoms out on the pump housing. Make sure the grease fitting on the connecting rod is facing the open side of the pump housing.
16. Install the the four socket screws and lock washers that secure the slider housing to the pump housing. Tighten in a diagonal pattern and torque to 400–440 in./lbs.
17. Lubricate the connecting rod bearing with Lubriplate 1242 grease by inserting the end of a grease gun onto the grease fitting on the end of the crankshaft pin. Lubricate the main housing bearing by inserting the end of a grease gun onto the grease fitting in the center of the crankshaft. Also, lubricate the connecting rod bushing by inserting the end of a grease gun onto the grease fitting on the connecting rod.
18. Position the front cover over the pump housing. Secure



the front cover using the four front cover screws.

19. Apply blue Loctite to the bottom 3–4 threads on the fluid section cylinder.
20. Turn the fluid section jam nut clockwise until it is flush against the top of the cylinder.
21. Lubricate the first several threads at the top of the cylinder with anti-seize compound.
22. Thread the cylinder into the pump housing, turning clockwise. When the connecting pin hole on the piston rod lines up with the hole in the slider assembly, insert the connecting pin.
23. Slide the retaining ring down on the slider assembly to cover the connecting pin.
24. Continue to turn the cylinder clockwise until the jam nut is flush against the slider housing.

**NOTE: If the nipple on the cylinder does not face the back of the unit, turn the cylinder counterclockwise until the nipple faces the back of the unit. Do not turn the cylinder more than one full turn.**

25. Once the nipple is positioned, turn the jam nut clockwise until it contacts the pump housing.
26. Tighten the jam nut with a wrench to tighten it against the slider housing.
27. Using a 7/8" open-end wrench, attach the fluid hose to the fitting on the back of the fluid section. Tighten securely.

## Replacing the Gears

1. Perform the Pressure Relief Procedure.
2. Using a Phillips screwdriver, remove the four front cover screws. Remove the front cover.
3. Using a 7/8" open-end wrench, loosen and remove the fluid hose from the fitting on the back of the fluid section.
4. Locate the four socket screws that secure the pump housing to the gear housing. Two are at the inside top of the pump housing and two are located on the external bosses at the bottom of the pump housing.
5. Using a 1/4" hex wrench, remove the four socket screws that secure the pump housing to the gear housing.
6. Slide the pump housing assembly away from the gear housing.
7. Remove and clean the housing gasket. Replace if damaged.
8. Remove the gear assembly and the 1/4" thrust balls from within the bearing bores that support the gear.

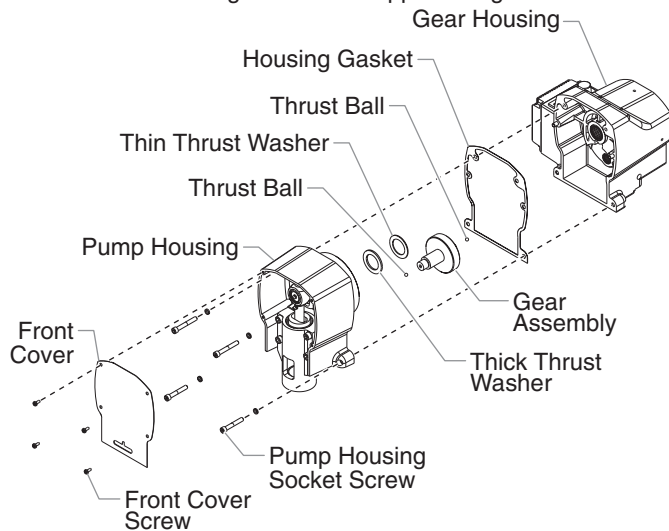

9. Inspect the gears for excessive wear and replace if damaged or worn. If the gear assembly is replaced, replace the two thrust balls as well.
10. Inspect the pinion gear on the end of the drive shaft for

wear. Replace if damaged or worn (refer to the "Servicing the Clutch Assembly" procedure in this section).

11. Inspect the output gear and the two thrust washers on the end of the crankshaft in the pump housing for wear. This gear is permanently attached to the crankshaft and pump housing. If this gear is worn, the pump housing must be replaced.

**NOTE: If replacing the pump housing, first remove the fluid section, slider housing, and slider assembly from the pump housing (refer to the "Replacing the Slider and Slider Housing" procedure in this section).**

12. Replace the thrust washers if worn. If the pump housing assembly is replaced, replace the thrust washers as well.

**NOTE: If any of the gears are worn and require replacement, check the grease in the gear housing for metal particles or shavings. Remove the contaminated grease. Replace the grease that has been removed with fresh Lubriplate GR-132 grease.**

13. Coat each of the thrust balls with a generous amount of grease. Install the thrust balls — one in the gear housing bore and one in the pump housing bore.
14. Coat the gear assembly with fresh Lubriplate GR-132 grease. Insert the gear assembly into the bore in the pump housing, pinion end first.
15. Generously coat both faces of each of the crankshaft thrust washers with grease.
16. Place the thick thrust washer onto the crankshaft up against the gear hub. Next, place the thin thrust washer up against the thick washer on the crankshaft.
17. Place the housing gasket over the gear housing dowel pins.
18. Carefully place the pump housing assembly in front of the gear housing assembly, lining up the gear housing dowel pins with their corresponding holes in the pump housing. Slide the pump housing onto the gear housing until there is no gap between the housings and gasket.

**IMPORTANT: Do not force the pump housing and gear housing together.**

19. Locate the four socket screws and lock washers that secure the pump housing to the gear housing. The longer screws (2.25") are fastened into the top internal holes. The shorter screws (2") are fastened into the bottom external bosses.
20. Using a 1/4" hex wrench, snug and tighten the socket screws in a crossing pattern. Torque to 200–230 in./lbs.
21. If the slider, slider housing, and fluid section were removed, reinstall by following the steps in the "Replacing the Slider and Slider Housing" procedure in this section.
22. Position the front cover over the pump housing. Secure the front cover using the four front cover screws.
23. Using a 7/8" open-end wrench, attach the fluid hose to the fitting on the back of the fluid section. Tighten securely.



# Servicing the Clutch Assembly

**NOTE:** When replacing the clutch armature, the clutch hub and clutch rotor must be replaced also. This will allow for even wear and maximum life on clutch parts.

## Removing/Replacing the Clutch Hub and Armature Assembly

1. Perform the Pressure Relief Procedure.
2. Using a 7/8" open-end wrench, loosen and remove the fluid hose from the fitting on the back of the fluid section.
3. Hold the transducer tube with a pliers to prevent it from rotating and turn the transducer nut counterclockwise using a 3/4" open-end wrench. When the nut disengages the filter housing, carefully remove the transducer from the filter housing.
4. Locate the wire that exits the rear of the electronic pressure control (EPC) housing and connects to the wire harness on the engine. Disconnect this wire from its connector at the engine wire harness.
5. Using a 1/2" wrench, remove the four hex screws and lock washers that secure the clutch housing to the gear housing.
6. Using a 9/16" socket, remove the two hex screws that secure the gear housing to the cart.
7. Slide the pump and gear housings away from the engine to disengage them from the clutch housing.

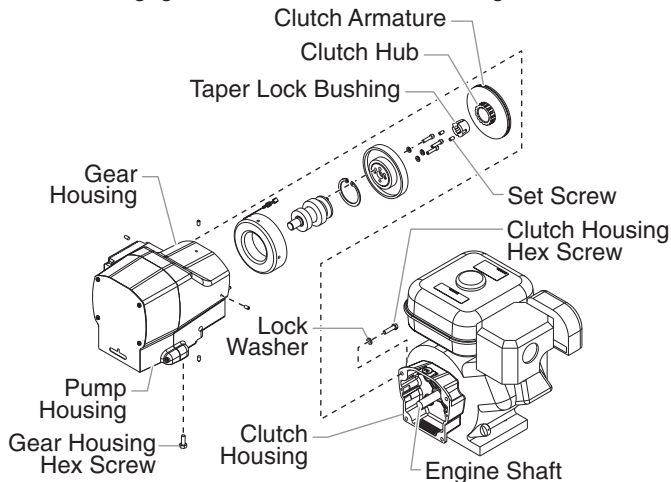

8. Locate the clutch hub and armature assembly on the end of the engine shaft. Note the two set screws as well as the unused, threaded hole in the taper lock bushing at the center of the clutch hub.
9. Using an 1/8" hex wrench, remove the two set screws from the taper lock bushing.
10. Thread one of the set screws into the unused, threaded hole on the taper lock bushing. As the screw tightens, the bushing will loosen. Once the bushing has loosened enough, slide the clutch hub and armature assembly off the engine shaft.

11. Before replacing the clutch hub and armature assembly the proper "set back" must be created. Using the SprayTECH hub set-up tool (P/N 0509925), create a "set back" of 0.20" between the friction surface of the clutch armature and the forward face of the clutch hub.

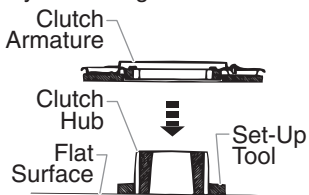

**NOTE:** A new clutch hub and armature assembly will come pre-assembled, but the "set back" will not be correct. The "set back" must still be created using the hub set-up tool.

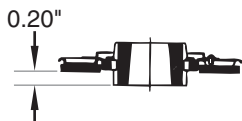

12. Line up the three holes in the taper lock bushing with the

three holes in the clutch hub and insert the bushing into the center of the clutch hub.

13. Line up the key on the taper lock bushing with the keyway on the engine shaft and slide the assembly onto the shaft with the holes facing out.
14. Apply blue Loctite to the two set screws and insert the screws into the taper lock bushing. Tighten the set screws only two turns at this time.
15. Line up the forward face of the clutch hub with the front face of the clutch housing. Using an 1/8" hex wrench, alternately tighten the set screws into the taper lock bushing. Torque to 65–75 in/lbs.

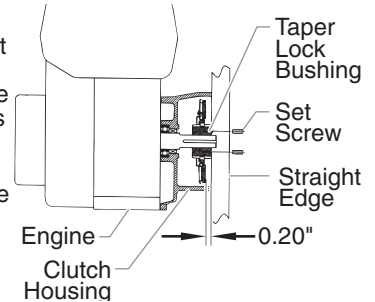

**NOTE:** To ensure the clutch hub and the clutch housing are aligned, hold a straight edge across the face of the clutch housing and then hold the clutch hub against the back of the straight edge while tightening the two set screws into the taper lock bushing.

16. Make sure the friction surface of the clutch armature is clean and free from oil or grease.

## Removing the Clutch Rotor, Clutch Field, and Drive Shaft Assembly

1. Follow steps 1–7 in "Removing/Replacing the Clutch Hub and Armature Assembly."
2. Locate the clutch rotor assembly on the end of the drive shaft assembly. Note the locations of the three socket screws and the two empty, threaded holes on the clutch rotor.
3. Using a 3/16" hex wrench, remove the three socket screws and lock washers that secure the clutch rotor to the drive shaft assembly.
4. Thread two of the socket screws into the empty, threaded holes and tighten alternately. This will push the clutch rotor away from the drive shaft assembly and pinion.



**Electrostatic discharge (ESD) potential could cause damage to electronic pressure control. Use SprayTECH ESD wrist strap P/N 0507958 or equivalent when working on electronic pressure control.**

5. Using a Phillips screwdriver, remove the four screws that secure the EPC assembly to the EPC housing. Carefully remove the EPC assembly from the housing.
6. Locate the two clutch field wires that pass from the gear housing into the EPC housing through a grommet in the back of the EPC housing. Remember the wire connection terminals on the EPC assembly (label if necessary) and disconnect the wires. Gently move the EPC assembly away from the housing and rest it on the work surface by the control housing.
7. Locate the four set screws that secure the clutch field to the gear housing. They are located on the exterior of the gear housing at the 12, 3, 6, and 9 o'clock positions while facing the clutch field end of the gear housing. Using an 1/8" hex wrench, remove the setscrews. Remember the location of the two clutch field wires with respect to the grommet and EPC housing.
8. Carefully slide the clutch field out of the gear housing, keeping the field square to the gear housing so it does not bind.
9. Remove the retaining ring in front of the ball bearing within the center bore of the gear housing.
10. Follow steps 2–6 in the "Replacing the Gears" procedure to remove the pump housing from the gear housing.
11. From the gear side of the gear housing, use a soft hammer to tap the gear end of the drive shaft through the gear housing.
12. Carefully slide the drive shaft assembly out from the gear housing, keeping the shaft square to the housing so it

does not bind.

- Remove the o-ring from inside the center bore of the gear housing from which the small ball bearing on the drive shaft assembly was removed.
- Clean the inside of the gear housing.

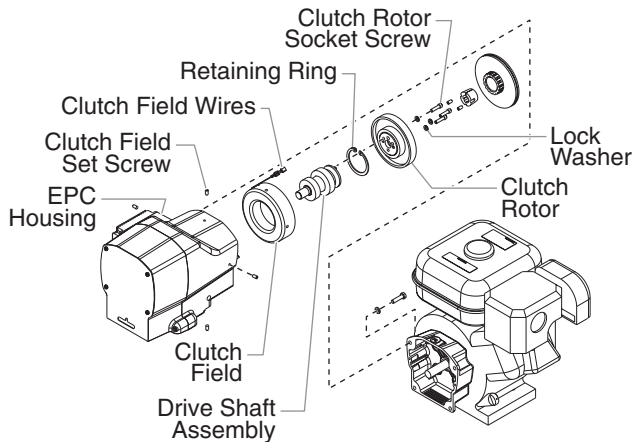

### Installing the Clutch Rotor Assembly, Clutch Field and Drive Shaft Assembly

- Install a new o-ring into the center bore of the gear housing.
- Apply Loctite retaining compound #635 to the outside diameter of the large bearing on the drive shaft. Do not get retaining compound on the faces of the bearing.
- Install the drive shaft assembly into the center bore of the gear housing, keeping it square to the housing so it does not bind. Once the large ball bearing on the drive shaft assembly is half way into its bore, a soft hammer may be used to gently tap the assembly into position.

**IMPORTANT: Do not force the drive shaft assembly into position.**

- Install the retaining ring into its groove next to the large ball bearing.
- Line up the four holes around the outside of the clutch field with the four set screw holes in the gear housing. The clutch field wires should be at approximately the 1 or 2 o'clock position.
- Route the two clutch field wires through the grommet and into the EPC housing.
- Carefully slide the clutch field into its bore in the gear housing until it "bottoms out" within the housing. Do not pinch the clutch field wires during installation.

**NOTE: Apply blue Loctite to the four clutch field set screws prior to installation.**

- Thread one of the set screws into its hole. Using an 1/8" hex wrench, rotate the screw slowly until it contacts the clutch field. **Do not tighten the set screw.** The tip of the set screw should mate with the drill point hole in the field. Check the clutch field for rotation. If it rotates within its bore, the set screw is not seated within the drill point.
- When the set screw is properly seated, install the remaining three set screws. **Do not tighten the set screws.**
- Using a crossing pattern, tighten each of the setscrews until they are snug. Once all four set screws are snug, use a crossing pattern to tighten and torque the set screws to 30–40 in./lbs.

**IMPORTANT: It is very important to evenly snug, tighten, and torque the clutch field set screws in a crossing pattern. This ensures the clutch field will stay centered in the gear housing.**

- Line up the three screw holes and dowel pin hole on the clutch rotor with the screw holes and dowel pin on the drive shaft assembly hub. Place the clutch rotor onto the hub.
- Using a 3/16" hex wrench, thread the three socket screws and lock washers through the clutch rotor and into the drive shaft assembly hub. Evenly snug, tighten, and

torque the socket screws to 75–85 in./lbs.

- Make sure the friction surface of the clutch rotor is clean and free from oil or grease.
- Follow steps 17–20 in the "Replacing the Gears" procedure to mate the pump housing with the gear housing.



**Electrostatic discharge (ESD) potential could cause damage to electronic pressure control. Use SprayTECH ESD wrist strap P/N 0507958 or equivalent when working on electronic pressure control.**

- Locate the two clutch field wires in the EPC housing. Gently pull the wires fully into the EPC housing so that there is no slack in the gear housing. Connect the wires to their proper terminals on the EPC board (refer to the labels created earlier in this procedure or the electrical schematic in the Parts List section of this manual).
- Carefully place the EPC assembly over the EPC housing taking care not to pinch any wires.
- Install the four screws that secure the EPC assembly to the EPC housing. Tighten securely.

### Mating the Gear Housing and the Clutch Housing

- Place the gear housing assembly onto the cart in front of the clutch housing. Line up the dowel pins in the gear housing with their corresponding holes in the clutch housing. Slide the gear housing assembly onto the clutch housing until there is no gap between the housings.
- Thread the four hex screws and lock washers through the clutch housing and into the gear housing.
- Using a 1/2" wrench, snug and tighten the hex screws in a crossing pattern. Torque to 140–155 in./lbs.
- Using a 9/16" socket, thread the two hex screws that secure the gear housing to the cart through the underside of the cart and into the gear housing. Torque to 100–120 in./lbs.
- Connect the wire from the EPC housing to its mating connector on the engine wire harness.
- Make sure that there is a white PTFE o-ring on the end of the transducer that gets inserted into the filter housing. Insert the transducer into the filter housing port.
- Hold the transducer tube with a pliers to prevent it from rotating, and turn the transducer nut clockwise with a 3/4" open-end wrench to tighten it into the filter housing. Torque the nut to 360–400 in./lbs.

### Checking the Clutch Gap

- Remove the plastic plug from the top of the clutch housing. Look through the port to locate the clutch armature and the clutch rotor.
- Check the gap between the clutch armature and the clutch rotor using a .016" feeler gauge and a .035" feeler gauge.
  - Insert each feeler gauge through the port and into the gap between the clutch armature and the clutch rotor. The .016" feeler gauge should fit in the gap. The .035" feeler gauge should not fit in the gap.
  - Pull the engine pull cord several times to rotate the clutch armature, checking the gap with each feeler gauge between each pull.
  - If the .016" gauge does not fit or the .035" gauge does fit at any checkpoint, the gap must be readjusted. This is done by relocating the clutch hub and armature assembly on the engine shaft. Refer to the "Removing/Replacing the Clutch Hub and Armature Assembly" procedure.

## Servicing the Fluid Section

Use the following procedures to service the valves and repack the fluid section.

1. Start the engine (refer to the procedures in the Operation section of this manual). Turn the pressure control knob clockwise to its maximum pressure setting.
2. Toggle the sprayer ON/OFF switch between the ON and OFF positions in short bursts until the slider assembly stops in a position where the fluid section connecting pin and retaining ring are visible through the slot in the slider housing.
3. Turn off the engine and perform the Pressure Relief Procedure.



**Before proceeding, follow the Pressure Relief Procedure outlined previously in this manual. Additionally, follow all other warnings to reduce the risk of an injection injury, injury from moving parts or electric shock.**

4. Loosen and remove the fluid hose from the fitting on the back of the cylinder of the fluid section.
5. Loosen and remove the four front cover screws. Remove the front cover.
6. Slide the retaining ring up on the slider assembly to expose the connecting pin.
7. Push the connecting pin forward through the slider assembly and piston. The connecting pin will fall out from the rear window of the slider housing where it can be retrieved.
8. Using a wrench, turn the jam nut counterclockwise to loosen it from the pump housing.
9. Turn the fluid section counterclockwise to remove it from the pump housing.
10. Place the fluid section cylinder upright in a vise by clamping on the wrench flats.

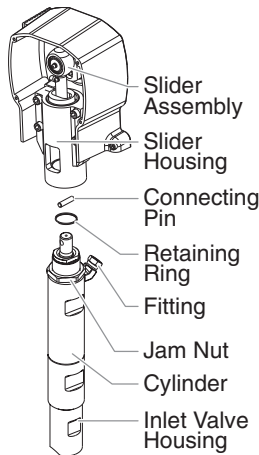

**NOTE: Do not over-tighten the vise. Damage to the cylinder may occur.**

11. Loosen and remove the lower housing and inlet valve housing.
12. Remove the inlet cage, inlet valve ball, inlet valve seat, and o-ring from the inlet valve.
13. Clean out any debris in the inlet valve housing and examine the housing and the inlet valve seat. If the seat is damaged, reverse to the unused side or replace the seat. If necessary, remove and clean inlet screen. Use snap ring pliers to remove retaining ring.
14. Using a wrench, remove the upper seal retainer.
15. Slide the piston rod out through the bottom of the cylinder.
16. Inspect the piston rod for wear and replace if necessary.
17. Remove the adapter ring and upper packing assembly from the top of the cylinder.
18. Remove the lower packing assembly from the bottom of the cylinder.

**NOTE: Be careful not to scratch, score, or otherwise damage the cylinder during removal of the packing assemblies.**

19. Remove the cylinder from the vise.
20. Insert the connection pin through the hole at the top of the piston rod and clamp each end of the connecting pin in the vise. This will hold the piston rod in position for disassembly.

**NOTE: Do not clamp the piston rod directly in the vise. Damage to the piston rod will occur.**

21. Using a 3/8" hex wrench, loosen and remove the outlet valve retainer from the piston rod.
22. Remove the outlet valve seal, outlet cage, outlet valve ball, nylon washer, and outlet valve seat from the outlet valve retainer.
23. Clean out any debris and examine the retainer and outlet valve seat. If the seat is damaged, reverse to the unused side or replace the seat.
24. Clean and inspect the outlet cage and outlet valve ball. Replace if they are worn or damaged.
25. Reassemble the outlet valve assembly into the piston rod in the reverse order of how it was disassembled. Use the new parts supplied with the packing kit during reassembly. Apply blue Loctite #242 to the threads of the outlet valve retainer. Torque the outlet valve retainer to 144 in./lbs.
26. Remove the piston rod from the vise.
27. Clean the cylinder. Inspect the cylinder for damage and replace if necessary.
28. Place the cylinder upright in a vise by clamping on the wrench flats.
29. Locate the new upper and lower packing assemblies and pack the areas between the packing lips with grease. Lubricate the o-rings on the exterior of the packings with grease.
30. Insert the upper packing assembly into the top of the cylinder with the large beveled edge facing down.
31. Insert the new adapter ring into the top of the cylinder with the small, center protrusion facing down. The adapter ring should rest on the upper packing assembly.
32. Apply blue Loctite #242 to the threads of the upper seal retainer. Thread the upper seal retainer into the cylinder but do not tighten.
33. Rotate the cylinder in the vise so that the bottom end is facing up.
34. Pre-form the lower packing using the lower packing sizing

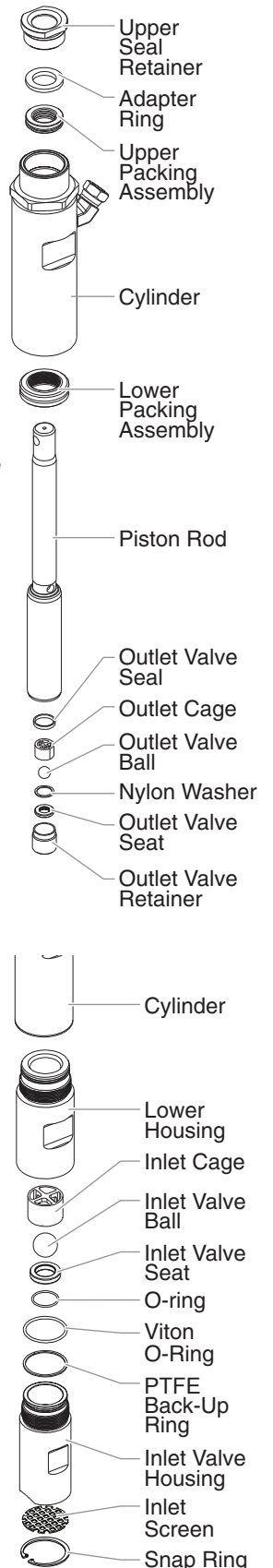

Install upper packing with large beveled edge facing down.



tool (included in the repacking kit).

- 35. Insert the lower packing assembly partially into the bottom of the cylinder with the large beveled edge facing toward the cylinder (beveled edge will be facing up when the cylinder is upright).

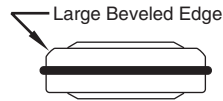

Install lower packing so large beveled edge will be facing up when the cylinder is upright.

- 36. Push the lower packing assembly into position using the lower packing insertion tool (see Fluid Section Assembly parts list for lower packing insertion tool P/N).
- 37. Place the piston insertion tool (included in the repacking kit) over the top of the piston rod.
- 38. Insert the piston rod into the bottom of the cylinder, through the lower packing assembly, through the upper packing assembly, and out through the upper seal retainer.
- 39. Tighten the upper seal retainer. Torque to 450–480 in./lbs.

**NOTE: When repacking the fluid section, make sure the raised lip on the bottom of the lower packing assembly is fully outside the packing around the piston rod after insertion of the piston rod.**

- 40. Apply blue Loctite to the bottom 3–4 threads on the cylinder. Turn the jam nut clockwise until it is flush against the top of the cylinder.
- 41. Lubricate the first several threads at the top of the cylinder with anti-seize compound. Remove the cylinder from vise.
- 42. Thread the cylinder into the pump housing, turning clockwise. When the connecting pin hole on the piston rod lines up with the hole in the slider assembly, insert the connecting pin.
- 43. Slide the retaining ring down on the slider assembly to cover the connecting pin.
- 44. Continue to turn the cylinder clockwise until the jam nut is flush against the pump housing.

**NOTE: If the nipple on the cylinder does not face the back of the unit, turn the cylinder counterclockwise until the nipple faces the back of the unit. Do not turn the cylinder more than one full turn.**

- 45. Once the nipple is positioned, turn the jam nut clockwise until it contacts the pump housing.
- 46. Tighten the jam nut with a wrench to tighten it against the pump housing. Torque to 960-1000 in./lbs.
- 47. Attach the high-pressure hose to the fitting on the back of the cylinder and tighten with a wrench. Do not kink the hose.
- 48. Install new PTFE o-ring onto lower housing. Thread lower housing into upper housing cylinder. Torque to 680-720 in./lbs.
- 49. Making sure that the new Viton o-ring and new PTFE back-up ring are lubricated and in place, reassemble the inlet valve assembly and thread it into the cylinder. Use the new parts supplied with the packing kit during reassembly. Tighten the inlet valve housing until the o-ring engages, then continue to tighten until snug.
- 50. Using a wrench, hold the cylinder by the wrench flats and torque the inlet valve housing to 1020–1080 in./lbs.
- 51. Place the front cover on the pump housing and secure in position using the four front cover screws.
- 52. Turn on the sprayer by following the procedure in the "Operation" section of this manual and check for leaks.

**NOTE: Repacking kit P/N 0555222 is available. For best results use all parts supplied in this kit.**



# Troubleshooting

## Problem

The unit will not run.

## Cause

1. The pressure is set too low.
2. Faulty or loose wiring.
3. The gas tank is empty.

## Solution

1. Turn the pressure control knob clockwise to supply power to the unit and increase the pressure setting.
2. Inspect or take to a SprayTECH authorized service center.
3. Fill the gas tank.

The unit will not prime.

1. The PRIME/SPRAY valve is in the SPRAY position.
2. Air leak in the siphon tube/siphon set.
3. The pump filter and/or inlet screen is clogged.
4. The siphon tube/siphon set is clogged.

1. Rotate the PRIME/SPRAY valve clockwise to the PRIME position.
2. Check the siphon tube/siphon set connection and tighten or re-tape the connection with PTFE tape.
3. Remove the pump filter element and clean. Remove the inlet screen and clean.
4. Remove the siphon tube/siphon set and clean.

The unit will not build or maintain pressure.

1. The spray tip is worn.
2. The spray tip is too large.
3. The pressure control knob is not set properly.
4. The pump filter, gun filter, or inlet screen is clogged.
5. Material flows from the return hose when the PRIME/SPRAY valve is in the SPRAY position.
6. Air leak in the siphon tube/siphon set.
7. There is external fluid leak.
8. There is an internal fluid section leak (packings are worn and/or dirty, valve balls are worn).
9. Worn valve seats

1. Replace the spray tip following the instructions that came with the spray gun.
2. Replace the spray tip with a tip that has a smaller orifice following the instructions that came with the spray gun.
3. Turn the pressure control knob clockwise to increase the pressure setting.
4. Remove the pump filter element and clean. Remove the gun filter and clean. Remove the inlet screen and clean.
5. Clean or replace the PRIME/SPRAY valve.
6. Check the siphon tube/siphon set connection and tighten or re-tape the connection with PTFE tape.
7. Check for external leaks at all connections. Tighten connections, if necessary.
8. Clean the valves and service the fluid section following the "Servicing the Fluid Section" procedure in the Maintenance section of this manual.
9. Reverse or replace the valve seats following the "Servicing the Fluid Section" procedure in the Maintenance section of this manual.

Fluid leakage at the upper end of the fluid section.

1. The upper packings are worn.
2. The piston rod is worn.

1. Repack the pump following the "Servicing the Fluid Section" procedure in the Maintenance section of this manual.
2. Replace the piston rod following the "Servicing the Fluid Section" procedure in the Maintenance section of this manual.

Excessive surge at the spray gun.

1. Wrong type of airless spray hose.
2. The spray tip worn or too large.
3. Excessive pressure.

1. Replace hose with a minimum of 50' of 3/8" grounded textile braid airless paint spray hose.
2. Replace the spray tip following the instructions that came with the spray gun.
3. Rotate the pressure control knob counterclockwise to decrease spray pressure.

Poor spray pattern.

1. The spray tip is too large for the material being used.
2. Incorrect pressure setting.
3. Insufficient fluid delivery.
4. The material being sprayed is too viscous.

1. Replace the spray tip with a new or smaller spray tip following the instructions that came with the spray gun.
2. Rotate the pressure control knob to adjust the pressure for a proper spray pattern.
3. Clean all screens and filters.
4. Add solvent to the material according to the manufacturer's recommendations.

The unit lacks power.

1. The pressure adjustment is too low.

1. Rotate the pressure control knob clockwise to increase the pressure setting.



# Importantes consignes de sécurité • Lire toutes ces consignes

avant d'utiliser l'appareil. Garder ces consignes.



**Indique une situation à risque, laquelle, si elle n'est pas évitée, peut entraîner des blessures graves, voire la mort.**



**Pour réduire les risques d'incendie ou d'explosion, de choc électrique et de blessure, vous devez lire et comprendre les directives figurant dans ce manuel. Familiarisez-vous avec les commandes et l'utilisation adéquate de l'équipement.**

## DANGER : INJECTION CUTANÉE

Le jet de haute pression produit par cet appareil peut transpercer la peau et les tissus sous-jacents, causant des blessures graves pouvant entraîner l'amputation.



**NE PAS TRAITER CE TYPE DE BLESSURE COMME UNE SIMPLE COUPURE! Une amputation peut en résulter. ON DOIT CONSULTER UN MÉDECIN SUR-LE-CHAMP.**

La pression maximale de ce pulvérisateur est d'environ 3 300 PSI / 22,8 MPa.

### MESURES PRÉVENTIVES :

- Ne pas pointer le pistolet vers une partie du corps.
- Ne pas pointer le pistolet vers une personne ou un animal; ne pas pulvériser non plus de produit dessus.
- NE JAMAIS mettre une partie du corps devant le jet de produit. NE JAMAIS toucher les fuites du flexible de pulvérisation.
- NE JAMAIS mettre la main, même gantée, devant le pistolet (les gants n'offrent aucune protection contre les blessures par injection).
- TOUJOURS verrouiller la détente, arrêter la pompe et relâcher toute la pression avant d'effectuer la maintenance de l'appareil ou de le laisser sans surveillance, d'en nettoyer le protège-embout ou l'embout, ou de remplacer ce dernier. La pression ne sera pas relâchée par le simple arrêt du moteur; pour ce faire, on doit se servir du bouton PRIME/SPRAY (se reporter à la section COMMENT LIBÉRER LA PRESSION, du présent manuel).
- TOUJOURS s'assurer que le protège-embout est en place avant de pulvériser. Il est cependant à noter que, s'il assure une certaine protection, ce dispositif joue surtout un rôle préventif.
- TOUJOURS retirer l'embout avant de vidanger ou de nettoyer l'appareil.
- TOUJOURS inspecter le flexible avant de commencer; celui-ci peut présenter des fuites attribuables à l'usure, à une flexion excessive ou à un traitement abusif, lesquelles fuites présentent des risques d'injection cutanée. Ne pas utiliser le flexible pour soulever ou tirer l'équipement.
- NE JAMAIS utiliser de pistolet sans verrou de détente et protège-doigts.
- Tous les accessoires (pistolets, embouts, rallonges, flexibles etc.) doivent pouvoir subir une pression nominale de 3 300 PSI / 22,8 MPa ou plus.
- Ne laissez pas l'appareil sous tension ou sous pression quand vous vous en éloignez. Quand vous n'utilisez pas l'appareil, éteignez-le et libérez la pression conformément aux instructions COMMENT LIBÉRER LA PRESSION, du présent manuel.
- Vérifiez que toutes les connexions sont bien serrées avant d'utiliser l'appareil. Toute pièce qui n'est pas fixée solidement risque d'être projetée violemment ou d'entraîner la fuite d'un jet de liquide à une pression extrêmement élevée, ce qui pourrait causer des blessures graves.
- Verrouillez toujours la détente quand vous ne pulvériser pas. Vérifiez que le verrou de la détente fonctionne correctement.

### REMARQUE À L'INTENTION DES MÉDECINS :

**Les injections cutanées sont des lésions traumatiques; il importe donc de les traiter sans délai. On NE DOIT PAS retarder ce traitement sous prétexte de vérifier la toxicité du produit en cause, celle-ci n'étant conséquente que dans le cas d'injection directe de certains produits dans le système sanguin. Il pourrait s'avérer nécessaire de consulter un plasticien ou un spécialiste en chirurgie reconstructive de la main.**

## DANGER : ÉMANATIONS DANGEREUSES

Certains produits (peintures, solvants, insecticides ou autres) peuvent être nocifs s'ils sont inhalés ou entrent en contact avec l'organisme. Les émanations de ces produits peuvent provoquer de graves nausées, évanouissements ou empoisonnements.



### MESURES PRÉVENTIVES :

- Se servir d'un masque ou d'un respirateur s'il y a risque d'inhalation (lire toutes les directives concernant ces dispositifs afin de s'assurer qu'ils offrent la protection requise).
- Porter des lunettes de protection.
- Porter les vêtements de protection prescrits par le fabricant du produit utilisé.



## DANGER : EXPLOSION OU INCENDIE

Les émanations de certains produits peuvent exploser ou s'enflammer, et risquent d'entraîner des dommages matériels ou de graves blessures.



### MESURES PRÉVENTIVES :

- S'assurer que l'aire de travail est dotée de moyens d'évacuation d'air vicié et d'introduction d'air frais pour éviter l'accumulation de vapeurs inflammables. Les vapeurs dégagées par la peinture ou les solvants peuvent provoquer une explosion ou s'enflammer.
- Ne pas pulvériser de produit dans un endroit clos.
- Ne pas travailler près de sources d'ignition (décharges électrostatiques ou étincelles provoquées par le branchement/ débranchement d'appareils ou la commutation d'interrupteurs, d'appareils électriques, flammes nues, veilleuses, objets chauds, etc.). La peinture ou le solvant s'écoulant dans l'équipement peut générer de l'électricité statique.
- Ne pas fumer dans l'aire de travail.
- L'aire de travail doit être munie d'un extincteur en bon état de marche.
- Prévoir un espace d'au moins 7.62 mètres entre la pompe et l'objet à pulvériser s'ils sont dans la même pièce bien ventilée (rallonger le flexible au besoin). Les vapeurs inflammables étant souvent plus lourdes que l'air, l'espace au-dessus du plancher doit être particulièrement bien aéré. La pompe contient des pièces qui produisent des arcs et émettent des étincelles pouvant enflammer les vapeurs.
- Les appareils et objets à l'intérieur ou à proximité de l'aire de travail doivent être adéquatement mis à la terre pour éviter les décharges électrostatiques.
- Veillez à ce que la zone soit propre et exempte de contenants de peinture ou de solvant, chiffons ou autres matériaux inflammables.
- Les flexibles dont on se sert doivent être conçus pour subir les pressions élevées et faits de matériaux conducteurs ou mis à la terre adéquatement; le pistolet sera mis à la terre par le biais de ses raccords aux flexibles.
- Pour les appareils électriques — Le cordon d'alimentation doit être branché à un circuit trifilaire.
- L'appareil doit toujours être vidangé à basse pression, embout retiré, dans un contenant métallique distinct. Tenir le pistolet contre la paroi du contenant de manière à mettre ce dernier à la terre et à prévenir les décharges électrostatiques.
- Toujours respecter les mises en garde et les directives du fabricant des produits et solvants utilisés. On doit connaître les produits contenus dans les peintures et solvants qu'on pulvérise. Lire les fiches techniques santé-sécurité (FTSS) et les étiquettes des contenants fournies avec les peintures et solvants. Suivre les consignes de sécurité du fabricant de peinture et de solvant.
- Ne pulvériser pas et ne les nettoyez pas avec des liquides ayant un point d'éclair inférieur à 21 °C (70 °F). Le point d'éclair est la température à laquelle le liquide peut créer suffisamment de vapeurs et s'enflammer.
- Le plastique est générateur de décharges électrostatiques; ne jamais en suspendre pour fermer une aire de travail ou en utiliser en guise de toile de protection lorsqu'on pulvérise un produit inflammable.
- Se servir de la pression la plus basse possible pour vidanger l'appareil.
- Ne pas pulvériser de produit sur la pompe.





## Importantes consignes de sécurité • Lire toutes ces consignes avant d'utiliser l'appareil. Garder ces consignes.

### DANGER : EXPLOSION CAUSÉE PAR DES PRODUITS INCOMPATIBLES



Ce type d'explosion peut entraîner des dommages matériels ou des blessures graves.

#### MESURES PRÉVENTIVES :

- Ne pas utiliser de produits contenant du chlore ou du javellisant.
- Ne pas utiliser de solvants à base de halons comme l'eau de javel, les agents antimoississure, le chlorure de méthylène et le trichloroéthane-1-1-1, lesquels ne sont pas compatibles avec l'aluminium.
- Communiquer avec le fournisseur du produit concerné pour en connaître la compatibilité avec l'aluminium.

### DANGER : GÉNÉRALITÉS

D'autres dangers peuvent entraîner des dommages matériels ou des blessures graves.

- Lire toutes les directives et consignes de sécurité avant d'utiliser l'appareil.
- Observer tous les codes locaux, provinciaux, d'état et nationaux régissant la ventilation, la prévention des incendies et le fonctionnement de l'appareil.
- Aux États-Unis, le gouvernement a adopté des normes de sécurité en vertu de l'Occupational Safety and Health Act (OSHA). Le cas échéant, on doit les consulter, notamment les parties 1910 des normes générales et 1926 des normes de construction.
- N'utiliser que les pièces autorisées par le fabricant; les utilisateurs qui choisiront d'utiliser des composants dont les caractéristiques techniques et les exigences en matière de sécurité sont inférieures devront en assumer tous les risques et responsabilités.
- Tous les raccords, les tuyaux et les bouchons de remplissage doivent être fixés solidement en place avant d'utiliser la pompe de pulvérisation. Toute pièce qui n'est pas fixée solidement risque d'être projetée violemment ou d'entraîner la fuite d'un jet de liquide à une pression extrêmement élevée, ce qui pourrait causer des blessures graves.
- Avant chaque utilisation, examiner tous les flexibles afin de confirmer l'absence de coupures, de fuites, d'abrasions ou de renflements. Vérifier également l'intégrité des raccords. Remplacer sans délai les pièces qui semblent présenter des défauts. Ne jamais tenter de réparer un flexible; remplacer ceux qui font défaut par des modèles haute pression, avec mise à la terre.
- Ne faites pas de noeud avec le tuyau et ne le tordez pas trop. Le tuyau à vide peut présenter des fuites suite à l'usure, les noeuds ou les mauvais traitements. Une fuite risque d'injecter du produit dans la peau.
- N'exposez pas le tuyau à des températures ou des pressions supérieures à celles spécifiées par le fabricant.
- Ne pas pulvériser à l'extérieur par grands vents.
- Porter des vêtements aptes à protéger la peau et les cheveux du produit utilisé.
- Ne pas utiliser le pistolet ou ne pas pulvériser de produits en présence d'enfants à proximité. Éloigner les enfants de l'équipement en tout temps.
- Ne pas s'étirer ni ne travailler sur un support instable. Toujours garder les deux pieds au sol pour rester en équilibre.
- Se servir de la pression la plus basse possible pour vidanger l'appareil.
- Rester vigilant et faire attention à ce que l'on fait.
- Ne pas se servir de l'équipement en cas de fatigue ou si vos aptitudes sont affaiblies par la consommation de drogues ou de boissons alcoolisées.
- Pour les appareils électriques — Débranchez toujours le cordon électrique de la prise avant de travailler sur l'équipement.
- N'utilisez pas le tuyau pour tirer ou soulever l'équipement.
- Ne pas soulever par la poignée de chariot en chargeant ou en déchargeant.

## Sécurité des moteurs à essence



Les produits chimiques contenus dans les vapeurs d'échappement de cet appareil sont reconnus par l'État de la Californie (États-Unis) comme étant cancérogènes. Ils peuvent également entraîner des anomalies congénitales ou d'autres dangers pour la santé.

- Les moteurs Honda sont conçus pour fonctionner en toute sécurité et avec une fiabilité maximale s'ils sont utilisés conformément aux instructions. Veuillez lire et comprendre le manuel de l'utilisateur de Honda avant de faire fonctionner le moteur. Le non-respect de ces consignes peut entraîner des dommages matériels ou des blessures physiques graves.
- Pour éviter tout risque d'incendie et fournir une ventilation adéquate, placez le moteur à une distance minimale de 1 mètre (3 pieds) des immeubles et d'autres équipements pendant son fonctionnement. Ne placez pas d'objets inflammables à côté du moteur.
- Tenez les enfants et les animaux domestiques à l'écart de la zone de travail; vous éviterez ainsi tout risque de brûlures sur les pièces chaudes du moteur et de blessures entraînées par les accessoires utilisés par le moteur pour son fonctionnement.
- Sachez comment arrêter rapidement le moteur, et assurez-vous que vous avez bien compris le fonctionnement de toutes les commandes. Ne permettez jamais à une personne de faire fonctionner le moteur sans connaître les instructions nécessaires.
- L'essence est extrêmement inflammable et explosive dans certaines conditions.
- Remplissez le réservoir de carburant dans une zone bien ventilée, moteur arrêté. Ne fumez pas et évitez toutes flammes ou étincelles dans la zone de remplissage de carburant ou dans une zone de stockage du carburant.
- Veillez à ne pas faire déborder le réservoir de carburant. Après remplissage, assurez-vous que le bouchon du réservoir est solidement vissé.
- Faites attention à ne pas renverser de carburant lors du remplissage du réservoir. Les vapeurs ou les éclaboussures de carburant peuvent s'enflammer. En cas d'éclaboussures, assurez-vous que la zone est bien sèche avant de faire démarrer le moteur.
- Ne faites jamais fonctionner le moteur dans un endroit fermé ou confiné. Les fumées d'échappement contiennent du monoxyde de carbone qui est un gaz toxique; une exposition prolongée peut entraîner une perte de conscience et peut s'avérer mortelle.
- Le silencieux devient très chaud pendant le fonctionnement et reste chaud quelque temps après l'arrêt du moteur. Faites attention à ne pas toucher le silencieux tant qu'il est chaud. Pour éviter des brûlures graves ou des risques d'incendie, laissez le moteur refroidir avant de le transporter ou de le ranger à l'intérieur.
- Ne transportez jamais le moteur si le réservoir est plein.



## Información de seguridad importante • Lea toda la información de seguridad antes de operar el equipo. Guarde estas instrucciones.



Indica una situación peligrosa que, de no evitarse, puede causar la muerte o lesiones graves.



Para reducir los riesgos de incendios, explosiones, descargas eléctricas o lesiones a las personas, lea y entienda todas las instrucciones incluidas en este manual. Familiarícese con los controles y el uso adecuado del equipo.

### PELIGRO: LESIÓN POR INYECCIÓN

El flujo de pintura a alta presión que produce este equipo puede perforar la piel y los tejidos subyacentes, ocasionando lesiones graves y posible amputación. CONSULTE A UN MÉDICO INMEDIATAMENTE.



**¡NO TRATE LA LESIÓN POR INYECCIÓN COMO UNA CORTADURA SIMPLE! La inyección puede ocasionar amputación. Consulte a un médico inmediatamente.**

La gama operativa máxima de la pistola es de 3300 PSI / 22.8 MPa de presión del líquido.

### PREVENCIÓN:

- NUNCA apunte la pistola a ninguna parte del cuerpo.
- No apunte con la pistola ni rocíe a cualquier persona o animal.
- NUNCA deje que ninguna parte del cuerpo toque el flujo de líquido. NO deje que el cuerpo toque una fuga de la manguera de líquido.
- NUNCA ponga la mano frente a la pistola. Los guantes no protegen contra una lesión por inyección.
- SIEMPRE ponga el seguro del gatillo, apague la bomba y libere toda la presión antes de dar servicio, limpiar la boquilla o protección, cambiar la boquilla o dejar la pistola sin supervisión. No se libera la presión al apagar el motor. Debe girarse la perilla PRIME/ SPRAY (CEBAR/ROCIAR) a PRIME (CEBAR) para aliviar la presión. Consulte el PROCEDIMIENTO PARA ALIVIAR LA PRESIÓN descrito en este manual.
- SIEMPRE mantenga la protección de la boquilla en su sitio al rociar. La protección de la boquilla sirve principalmente de dispositivo de advertencia.
- SIEMPRE retire la boquilla rociadora antes de enjuagar o limpiar el sistema.
- La manguera de pintura puede presentar fugas por desgaste, dobleces y maltrato. La fuga puede inyectar material traspasando la piel. Inspeccione la manguera antes de cada uso. No use mangueras para levantar o tirar del equipo.
- NUNCA use una pistola rociadora sin contar con el seguro y la protección del gatillo.
- Todos los accesorios deben tener capacidades nominales de 3300 PSI / 22.8 MPa como mínimo. Esto incluye las boquillas rociadoras, pistolas, extensiones y manguera.
- No deje el aparato con corriente ni con presión cuando nadie esté pendiente de ella. Cuando no utilice el aparato, apáguelo y libere la presión siguiendo las instrucciones del PROCEDIMIENTO PARA ALIVIAR LA PRESIÓN descrito en este manual.
- Antes de utilizar el aparato, verifique que todas las conexiones son seguras. Las partes no aseguradas pueden ser expulsadas con gran fuerza o filtrar fluido a alta presión y provocar lesiones severas.
- Ponga siempre el seguro del gatillo cuando no esté pulverizando. Verifique que el seguro del gatillo funciona correctamente.

**NOTA PARA EL MÉDICO: La inyección a través de la piel es una lesión traumática. Es importante tratar la lesión tan pronto sea posible. NO retrase el tratamiento para investigar la toxicidad. La toxicidad es un factor a considerar con ciertos revestimientos inyectados directamente en la corriente sanguínea. Puede ser aconsejable consultar con un cirujano plástico o un cirujano especialista en reconstrucción de las manos.**

### PELIGRO: VAPORES PELIGROSOS

Las pinturas, solventes, insecticidas y demás materiales pueden ser nocivos si se inhalan o toman contacto con el cuerpo. Los vapores pueden causar náuseas graves, desmayos o envenamamiento.



### PREVENCIÓN:

- Use un respirador o mascarilla si pueden inhalarse los vapores. Lea todas las instrucciones suministradas con la mascarilla para revisar que brinde la protección necesaria.
- Use lentes protectores.
- Use ropa protectora según lo indique el fabricante del revestimiento.



### PELIGRO: EXPLOSIÓN O INCENDIO

Los vapores de solventes y pinturas pueden explotar o inflamarse. Pueden producirse daños materiales, lesiones graves o ambos.



### PREVENCIÓN:

- Cuente con escape y entrada de aire fresco para mantener el aire dentro de la zona de aplicación sin acumulaciones de vapores inflamables. Los gases producidos por solventes o pinturas pueden causar explosiones o incendios.
- No rocíe en lugares cerrados.
- Evite todas las fuentes de ignición como las chispas de electricidad estática, las llamas expuestas, appliances eléctricas, las luces piloto y los objetos calientes. La conexión o desconexión de cables eléctricos o interruptores de luz operativos puede producir chispas. Si la pintura o el solvente fluyen por el equipo se puede generar electricidad estática.
- No fume en el área de aplicación.
- Debe haber un extintor de incendios en buen estado.
- Coloque la bomba de pintura a un mínimo de 7.62 meters (25 pies) del objeto a pintar dentro de un área bien ventilada (añada más manguera si es necesario). Los vapores inflamables son generalmente más pesados que el aire. El área debe estar sumamente bien ventilada.
- El equipo y los objetos dentro y alrededor del área a pintar deben estar debidamente conectados a tierra para evitar las chispas de estática.
- Mantenga el área limpia y libre de contenedores de pintura o solvente, trapos y otros materiales inflamables.
- Use solamente una manguera conductora o conectada a tierra para líquidos a alta presión. La pistola debe conectarse a tierra a través de las conexiones de la manguera.
- Para las aparatos eléctricos — Debe conectarse el cable eléctrico a un circuito a tierra.
- Siempre enjuague la unidad dentro de un recipiente metálico separado, con la bomba a baja presión y habiendo sacado la boquilla rociadora. Sostenga la pistola firmemente contra el costado del recipiente para conectar a tierra el mismo y evitar chispas de estática.
- Siga las advertencias e instrucciones del fabricante del material y del solvente. Conozca los contenidos de las pinturas y los solventes con los que rocía. Lea todas las Hojas de Datos sobre Seguridad de Materiales (MSDS) y las etiquetas del contenedor provistas con las pinturas y los solventes. Siga las instrucciones de seguridad del fabricante de pinturas o solventes.
- No pulverice ni limpie con líquidos que tengan un punto de inflamación por debajo de 21 °C (70°F). El punto de inflamación es la temperatura a la que un fluido puede producir vapores suficientes para encenderse.
- El plástico puede causar chispas de estática. Nunca cuelgue plásticos para cerrar una zona a pintar. No use mantas plásticas al aplicar materiales inflamables.
- Use la presión más baja posible para enjuagar el equipo.
- No rocíe el ensamblaje de la bomba.







## Información de seguridad importante • Lea toda la información de seguridad antes de operar el equipo. Guarde estas instrucciones.

### PELIGRO: POSIBLE EXPLOSIÓN DEBIDO A MATERIALES INCOMPATIBLES

Causará daños materiales o lesiones graves.

#### PREVENCIÓN:

- No use materiales que contengan blanqueador o cloro.
- No use solventes de hidrocarburos halogenados como blanqueador, mohocida, cloruro de metileno y 1,1,1 tricloroetano. No son compatibles con el aluminio.
- Diríjase al proveedor de revestimientos para obtener los datos de compatibilidad del material con el aluminio.

### PELIGRO: GENERAL

Puede causar daños materiales o lesiones graves.

#### PREVENCIÓN:

- Lea todas las instrucciones y las precauciones de seguridad antes de operar el equipo.
- Siga todos los códigos locales, estatales y nacionales correspondientes que rijan la ventilación, prevención de incendios y operación.
- Se han adoptado las normas de seguridad del Gobierno de los Estados Unidos según la Ley de seguridad ocupacional y salud (Occupational Safety and Health Act, OSHA). Deben consultarse estas normas, particularmente el apartado 1910 de las Normas generales y el apartado 1926 de las Normas de construcción.
- Utilice solamente componentes autorizados por el fabricante. El usuario asume todo riesgo y responsabilidad al utilizar componentes que no cumplan con las especificaciones mínimas y requisitos de seguridad del fabricante de la bomba.
- Todos los acopladores, las mangueras y las tapas de los filtros deben estar asegurados antes de operar la bomba de rocío. Las partes no aseguradas pueden ser expulsadas con gran fuerza o filtrar fluido a alta presión y provocar lesiones severas.
- Antes de cada uso, revise todas las mangueras en busca de cortes, fugas, abrasión o hinchazón de la cubierta. Revise si hay daños o movimiento de los acoplamiento. Cambie inmediatamente la manguera si existe alguna de estas condiciones. Nunca repare una manguera de pintura. Cámbiela por otra manguera conectada a tierra apta para alta presión.
- No retuerza ni doble la manguera en exceso. En la manguera airless pueden aparecer fugas a causa del desgaste, de retorcimientos o de un mal uso. Una fuga puede inyectar material en la piel.
- No exponga la manguera a temperaturas o presiones que superen las especificadas por el fabricante.
- No pinte en exteriores en días con viento.
- Use ropa que mantenga la pintura alejada de la piel y el cabello.
- No lo opere ni rocíe cerca de los niños. Mantenga a los niños alejados del equipo en todo momento.
- No se asome ni se pare sobre soportes inestables. Mantenga siempre la posición firme y el equilibrio efectivos.
- Use la presión más baja posible para enjuagar el equipo.
- Manténgase alerta y mire lo que hace.
- No utilice la unidad cuando se encuentre cansado o bajo la influencia de las drogas o el alcohol.
- Para las aparatos eléctricos — Desenchufe siempre el cable antes de trabajar en el equipo.
- No utilice la manguera como elemento de fuerza para tirar del equipo o levantarlo.
- No levantar por la manija del carro al cargar o descargando.



## Seguridad del motor de gasolina



**El escape del motor de esta unidad contiene productos químicos que el Estado de California reconoce que causan cáncer, defectos congénitos u otros daños a la reproducción.**

- Los motores Honda han sido diseñados para ofrecer un servicio seguro y fiable, si son manejados de acuerdo con las instrucciones. Lea y comprenda el Manual del Propietario de Honda antes de hacer funcionar el motor. Si no hace esto, podrían producirse lesiones personales o daños en el equipo.
- Para evitar riesgos de incendio y proporcionar una ventilación adecuada, mantenga el motor como mínimo a 1 metro (tres pies) de edificios y de otros equipos durante su funcionamiento. No coloque objetos inflamables cerca del motor.
- Los niños y los animales de compañía deben mantenerse alejados del área de trabajo, debido a la posibilidad de quemaduras producidas por los componentes calientes del motor o de daños producidos por el equipo al que haga funcionar el motor.
- Conozca el modo de detener rápidamente el motor, y entienda el funcionamiento de todos los controles. No permita que nadie haga funcionar el motor sin las instrucciones adecuadas.
- La gasolina es extremadamente inflamable y es explosiva en determinadas circunstancias.
- Reabastézcase de combustible en una zona bien ventilada y con el motor apagado. No fume ni permita que haya llamas ni chispas en el área de reabastecimiento de combustible ni donde se almacene la gasolina.
- No llene excesivamente el tanque de combustible. Tras repostar, asegúrese de que la tapa del tanque está adecuadamente cerrada y asegurada.
- Tenga cuidado de no derramar combustible cuando realice el reabastecimiento. Los vapores del combustible o el combustible derramado pueden inflamarse. Si se derrama combustible, asegúrese de que el área esté seca antes de arrancar el motor.
- Nunca haga funcionar el motor en un área cerrada o reducida. Los gases de escape contienen monóxido de carbono tóxico: su exposición puede causar la pérdida del conocimiento y puede originar la muerte.
- El silenciador se calienta mucho durante el funcionamiento y permanece caliente durante un tiempo después de que el motor esté parado. Tenga cuidado de no tocar el silenciador mientras está caliente. Para evitar quemaduras graves o riesgos de incendio, deje que el motor se enfríe antes de transportarlo o almacenarlo en el interior.
- Nunca transporte una unidad con gasolina en el tanque.

# Parts List

## Main Assembly

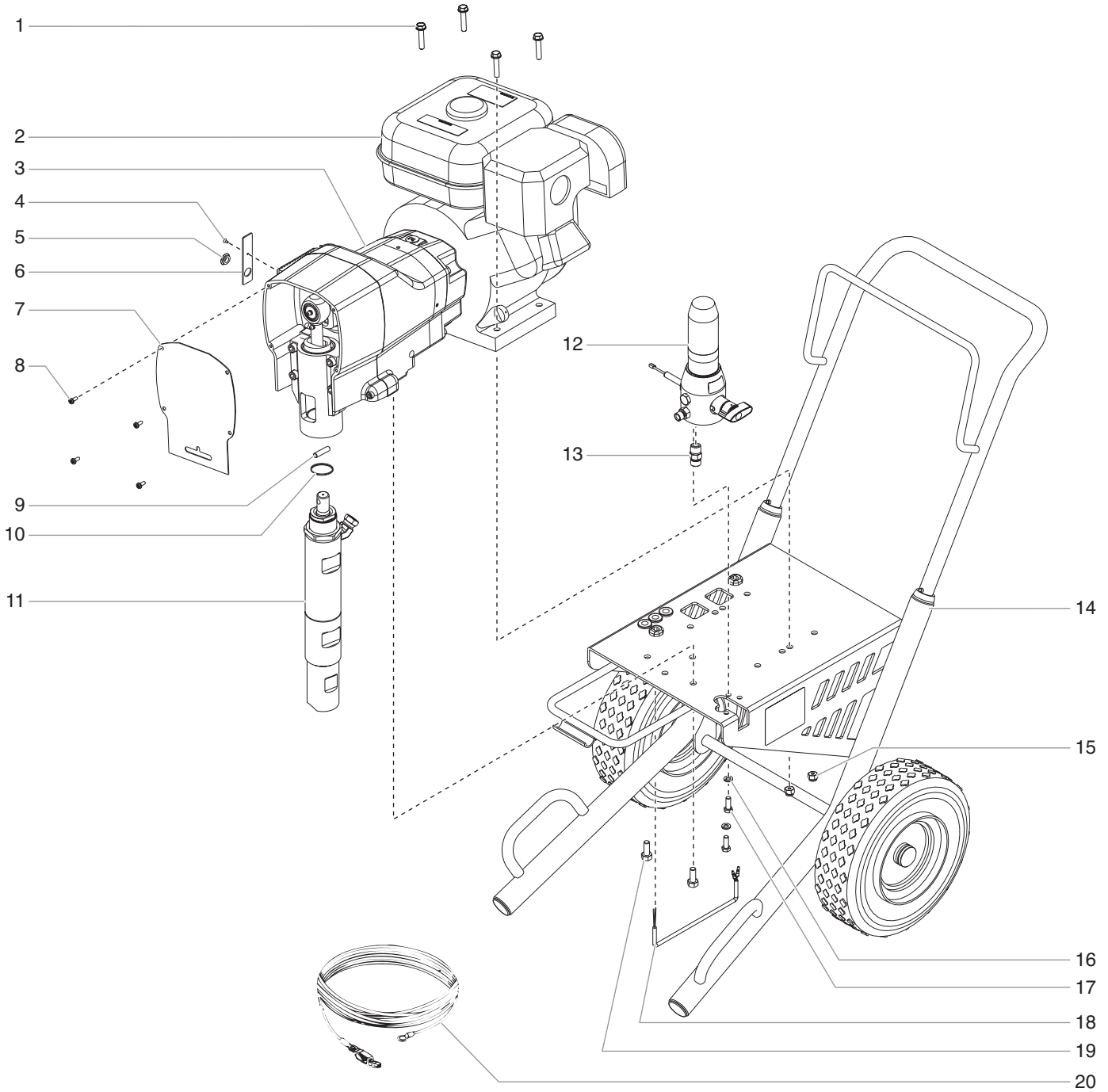

Item	Part #	Description	Quantity	Item	Part #	Description	Quantity
1	0509550	Hex screw .....	4	12	-----	Filter assembly.....	1
2	-----	Engine.....	1	13	0508343	Fitting, 3/8" .....	1
3	-----	Drive assembly .....	1	14	-----	Cart assembly.....	1
4	0509635	Screw .....	1	15	0509551	Lock nut .....	4
5	0509634	Port plug .....	1	16	0507786	Lock washer.....	2
6	0509627	Controller cover .....	1	17	0507787	Hex screw .....	2
7	0555216	Front cover w/ label .....	1	18	0555201	Wire harness.....	1
8	0509552	Screw .....	4	19	0509553	Screw .....	2
9	0509520	Connecting pin.....	1	20	0509928	Grounding cable .....	1
10	0509521	Retaining ring.....	1	21	0507785	Return hose (not shown) .....	1
11	0555265	Fluid section assembly .....	1	22	0507404	Hose, high pressure (not shown) .....	1

# Drive Assembly

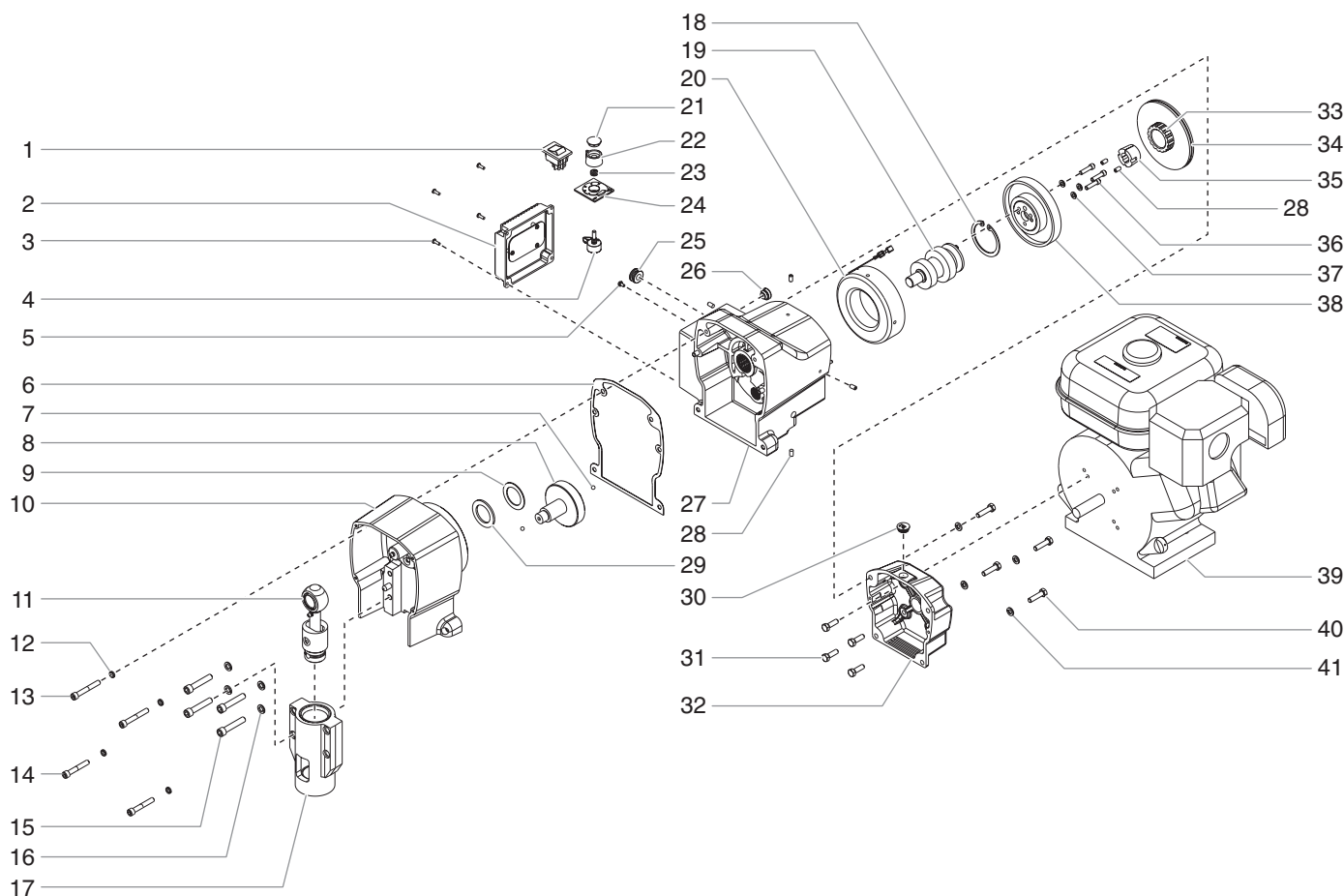

Item	Part #	Description	Quantity
1	9850936	ON/OFF switch	1
2	0509558	Electronic pressure control assembly	1
3	0509556	Screw	4
4	0507973	Potentiometer	1
5	9800340	Ground screw	1
6	0509495	Gasket	1
7	0509562	Ball	2
8	0509564	Gear assembly	1
9	0509559	Thrust washer	1
10	0555245	Pump housing	1
11	0555230	Slider assembly	1
12	0509541	Washer	4
13	0509539	Socket screw, 2.25"	2
14	0509540	Socket screw, 2"	2
15	0509561	Socket screw	4
16	53171	Lock washer	4
17	0555249	Slider housing	1
18	0509565	Retaining ring	1
19	0509567	Drive shaft assembly	1
20	0555902	Clutch field assembly	1
21	0507748	Cap	1

Item	Part #	Description	Quantity
22	0507740	Pressure control knob	1
23	0507749	Seal nut	1
24	0509557	Mounting plate	1
25	0507784	Grommet, 7/16"	1
26	0509531	Grommet, liquid tight	1
27	0555189	Gear housing	1
28	0509573	Set screw	6
29	0509563	Thrust bearing	1
30	0509574	Plug	1
31	0509538	Screw	4
32	0555633	Clutch housing	1
33	0509619	Clutch hub	1
34	0509570	Clutch hub and armature (includes items 28(2), 33, and 35)	1
35	0509571	Taper lock bushing (includes item 28(2))	1
36	0509566	Socket screw	3
37	0295694	Lock washer	3
38	0509568	Clutch rotor	1
39	0555621	Engine	1
40	0509569	Hex screw	4
41	0507786	Lock washer	4

**NOTE: All electrical work should be performed by a SprayTECH authorized service center.**

# Fluid Section Assembly (P/N 0555265)

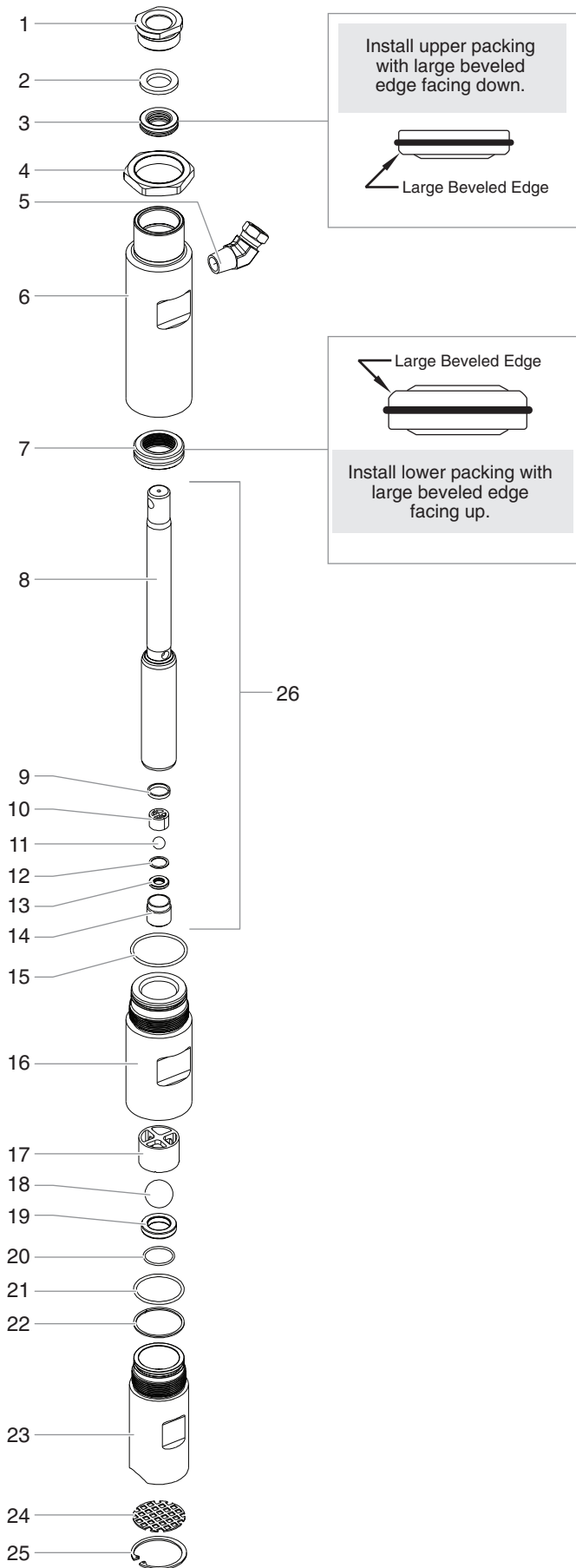

Item	Part #	Description	Quantity
1	0509536	Upper seal retainer .....	1
2	0509430	Adapter ring .....	1
3	0509935	Upper packing assembly .....	1
4	0509505	Jam nut .....	1
5	0507403	Fitting .....	1
6	0555906	Upper housing cylinder .....	1
7	0509936	Lower packing assembly .....	1
8	0555909	Piston .....	1
9	0509648	Outlet valve seal .....	1
10	0509601	Outlet cage .....	1
11	0509710	Outlet valve ball .....	1
12	0507454	Nylon washer .....	1
13	0509655	Outlet valve seat .....	1
14	0507733	Outlet valve retainer .....	1
15	0507498	Lower housing o-ring .....	1
16	0555907	Lower housing .....	1
17	0509602	Inlet cage .....	1
18	0509707	Inlet valve ball .....	1
19	0509623	Inlet valve seat .....	1
20	0509708	O-ring, PTFE .....	1
21	0509652	Viton o-ring .....	1
22	0509653	Back-up ring, PTFE .....	1
23	0555903	Inlet valve .....	1
24	0555217	Inlet screen .....	1
25	0349391	Snap ring .....	1
26	0555783	Piston assembly (includes items 8-14) .....	1
	0555222	Repacking kit (includes items 2, 3, 7, 9, 11, 12, 18, and 20-22)	
	0509934	Lower packing insertion tool	

**NOTE: When repacking the fluid section, make sure the raised lip on the bottom of the lower packing is fully outside the packing around the piston rod after insertion of the piston rod.**



## Cart Assembly

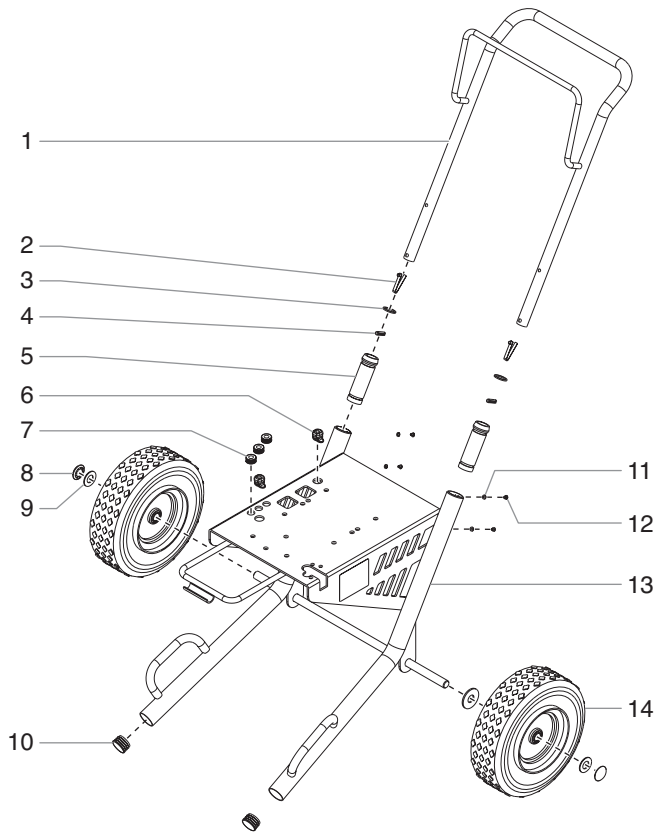

Item	Part #	Description	Quantity
1	0507766	Handle (includes items 2-5, 11, and 12)....	1
2	9841504	Snap button .....	2
3	0295609	Handle washer.....	2
4	0295610	Roll pin.....	2
5	0295607	Handle sleeve.....	2
6	0555603	Strain relief.....	2
7	0507784	Grommet.....	3
8	0509625	Axle cap.....	2
9	0509626	Wheel spacer.....	2
10	9885571	Plug.....	2
11	0509386	Lock washer.....	4
12	0295608	Screw.....	4
13	0555218	Cart (includes item 10) .....	1
14	0509624	Wheel .....	2

## Filter Assembly

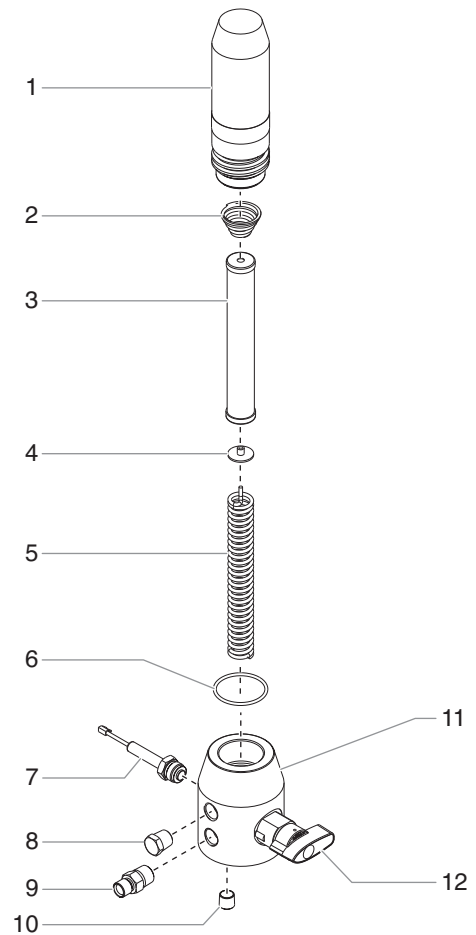

Item	Part #	Description	Quantity
1	0508723	Filter body .....	1
2	0508602	Filter spring .....	1
3	0508748	Filter, 60 mesh (standard).....	1
	0508451	Filter, 30 mesh (optional)	
	0508452	Filter, 100 mesh (optional)	
4	0508603	Adapter .....	1
5	0508749	Filter support spring.....	1
6	0508725	O-ring, PTFE .....	1
7	0507737	Transducer.....	1
8	0509420	Plug, 3/8" .....	1
9	0509738	Outlet fitting, 3/8" .....	1
10	0295697	Plug, 1/4" .....	1
11	0555625	Filter housing .....	1
12	0507690	PRIME/SPRAY valve assembly.....	1

# PRIME/SPRAY Valve Assembly (P/N 0507690)

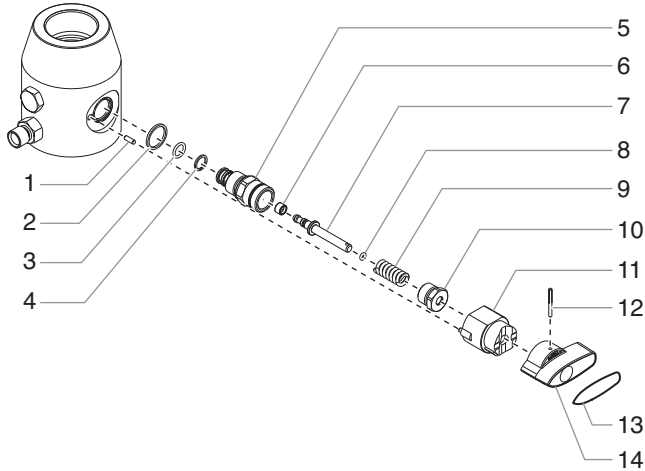

<u>Item</u>	<u>Part #</u>	<u>Description</u>	<u>Quantity</u>
1	0507736	Dowel pin .....	1
2	0507745	Gasket .....	1
3	5000529	O-ring, PTFE .....	1
4	0507741	O-ring, Viton.....	1
5	0507744	Valve housing .....	1
6	0507746	Valve seat .....	1
7	0507743	Valve stem .....	1
8	5006547	O-ring, Viton.....	1
9	0507747	Spring .....	1
10	0507742	Valve retainer.....	1
11	0507735	Cam base .....	1
12	5006543	Groove pin .....	1
13	0508330	Label, SprayTECH.....	1
14	0507662	Valve handle .....	1

# Electrical Schematic

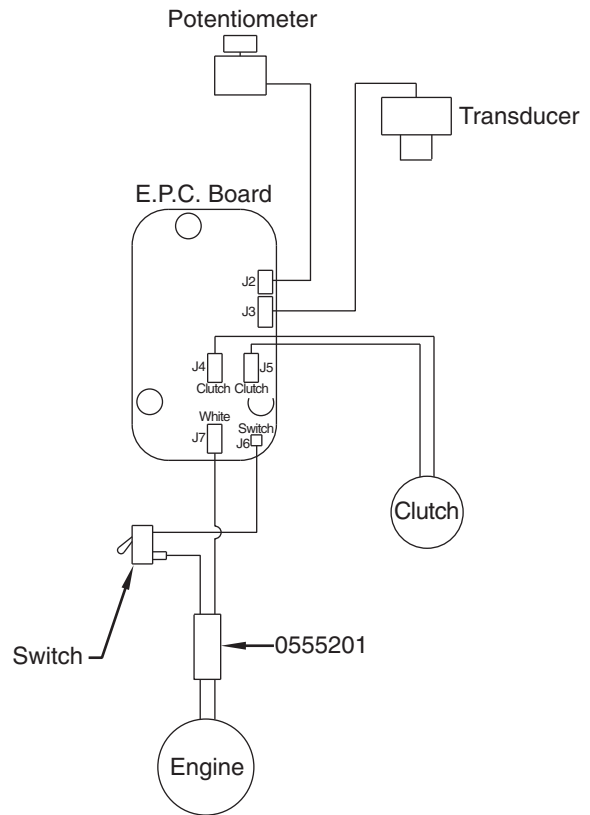

# Labels

<u>Part #</u>	<u>Description</u>
0295840	Warning label, explosion
0295841	Warning label, injection
0295805	Shock hazard label
0509819	"No Oil" label

## Accessories

<b>Part No.</b>	<b>Description</b>
0550xxx	Tip Assembly
0297078	Tip Guard (11/16")
0297070	Tip Guard (7/8")
0508342	Hose, 25' x 3/8"
0291006	Hose, 50' x 3/8"
0291002	Hose, Wireless, 25' x 1/4"
0291000	Hose, Wireless, 50' x 1/4"
0093896	Hose Connector, 1/4" x 1/4"M
0088162	Fitting, 3/8" M x 1/4" M
0088160	Fitting, 3/8" M x 3/8" M
0088154	Pressure Gauge, 0-5000 PSI
0152001	Power Roller Gun Attachment, 11/16"
0152308	9" Roller Cover, 3/8" Nap
0152307	9" Roller Cover, 1/2" Nap
0152309	9" Roller Cover, 3/4" Nap
0152310	9" Roller Cover, 1-1/4" Nap
0152235	12" Roller Cover, 1/2" Nap
0152236	12" Roller Cover, 3/8" Nap
0152237	12" Roller Cover, 3/4" Nap
0152238	12" Roller Cover, 1-1/4" Nap
0093930	Anti-Seize Compound
0152909	R-10 Telescoping Roller, 9", 3/8" Nap
0152900	R-10 Telescoping 12" Roller, 3/8" Nap
0296329	G-10 XL Four Finger Airless Spray Gun (no tip)
0296235	G-10 XL Four Finger Airless Spray Gun with 517 reversible tip
0296260	G-10 XL Two Finger Airless Spray Gun (no tip)
0296236	G-10 XL Two Finger Airless Spray Gun with 517 reversible tip
0296326	G-10 XL Four Finger Spray Pack with 50' x 1/4" airless hose
0296327	G-10 XL Two Finger Spray Pack with 50" x 1/4" airless hose
0296297	G-12 XL Airless Spray Gun with 517 reversible tip
0296330	G-12 XL Spray Pack with 50' x 1/4" airless hose
0296470	G-15 XL Airless Spray Gun with 517 Reversible Tip
0296328	G-15 XL Spray Pack with 50' x 1/4" airless hose
0279920	Separating oil
0507958	Electrostatic discharge (ESD) wrist strap
9870307	Grease, 6 lb. can

## Limited Warranty

SprayTECH, a division of Wagner Spray Tech Corporation ("SprayTECH"), warrants that at the time of delivery to the original purchaser for use ("End User"), the equipment covered by this warranty is free from defects in material and workmanship. With the exception of any special, limited, or extended warranty published by SprayTECH, SprayTECH's obligation under this warranty is limited to replacing or repairing without charge those parts which, to SprayTECH's reasonable satisfaction, are shown to be defective within twelve (12) months after sale to the End User. This warranty applies only when the unit is installed and operated in accordance with the recommendations and instructions of SprayTECH.

This warranty does not apply in the case of damage or wear caused by abrasion, corrosion or misuse, negligence, accident, faulty installation, substitution of non- SprayTECH component parts, or tampering with the unit in a manner to impair normal operation.

Defective parts are to be returned to an authorized SprayTECH sales/service outlet. All transportation charges, including return to the factory, if necessary, are to be borne and prepaid by the End User. Repaired or replaced equipment will be returned to the End User transportation prepaid.

THERE IS NO OTHER EXPRESS WARRANTY. SPRAYTECH HEREBY DISCLAIMS ANY AND ALL IMPLIED WARRANTIES INCLUDING, BUT NOT LIMITED TO, THOSE OF MERCHANTABILITY AND FITNESS FOR A PARTICULAR PURPOSE, TO THE EXTENT PERMITTED BY LAW. THE DURATION OF ANY IMPLIED WARRANTIES WHICH CANNOT BE DISCLAIMED IS LIMITED TO THE TIME PERIOD SPECIFIED IN THE EXPRESS WARRANTY. IN NO CASE SHALL SPRAYTECH LIABILITY EXCEED THE AMOUNT OF THE PURCHASE PRICE. LIABILITY FOR CONSEQUENTIAL, INCIDENTAL OR SPECIAL DAMAGES UNDER ANY AND ALL WARRANTIES IS EXCLUDED TO THE EXTENT PERMITTED BY LAW.

SPRAYTECH MAKES NO WARRANTY AND DISCLAIMS ALL IMPLIED WARRANTIES OF MERCHANTABILITY AND FITNESS FOR A PARTICULAR PURPOSE WITH RESPECT TO ACCESSORIES, EQUIPMENT, MATERIALS OR COMPONENTS SOLD BUT NOT MANUFACTURED BY SPRAYTECH. THOSE ITEMS SOLD, BUT NOT MANUFACTURED BY SPRAYTECH (SUCH AS GAS ENGINES, SWITCHES, HOSES, ETC.) ARE SUBJECT TO THE WARRANTY, IF ANY, OF THEIR MANUFACTURER. SPRAYTECH WILL PROVIDE THE PURCHASER WITH REASONABLE ASSISTANCE IN MAKING ANY CLAIM FOR BREACH OF THESE WARRANTIES.

## Patents

These products are covered by one or more of the following U.S. patents:

6,031,352	5,848,566	5,769,321	5,725,364	5,671,656	5,435,697	5,228,842
5,346,037	5,252,210	5,217,238	5,192,425	4,908,538	4,768,929	4,744,571
D384,676	6,179,222	5,934,883	4,723,892			

Material Safety Data Sheets (MSDS) are available on SprayTECH's website or by calling Technical Service.

**SprayTECH**  
 1770 Fernbrook Lane  
Minneapolis, MN 55447

Technical Assistance: 1-800-292-4637  
Order Entry: 1-800-443-4500  
Fax: 1-800-525-9501

[www.spraytechinc.com](http://www.spraytechinc.com)