

# **EPX2305**

## **Piston Pump**

**Owner's Manual**



**Model Numbers:**  
**0507007 Upright Cart**  
**0507017 Low Boy Cart**

**SprayTECH**  
THE DEPENDABLE CHOICE™

**SprayTECH**  
1770 Fernbrook Lane  
Minneapolis, MN 55447

Technical Assistance: 1-800-292-4637  
Order Entry: 1-800-443-4500  
Fax: 1-800-525-9501

[www.spraytechinc.com](http://www.spraytechinc.com)

# Table of Contents

<b>Safety Precautions</b> .....	<b>2</b>
Français .....	14
Español .....	16
<b>General Description</b> .....	<b>4</b>
<b>Operation</b> .....	<b>4</b>
Setup .....	4
Preparing to Paint.....	4
Painting .....	5
Pressure Relief Procedure .....	5
<b>Spraying</b> .....	<b>6</b>
Spraying Technique .....	6
Practice .....	6
<b>Cleanup</b> .....	<b>6</b>
<b>Maintenance</b> .....	<b>7</b>
General Repair and Service Notes.....	7
Replacing the PRIME/SPRAY Valve.....	7
Replacing the Filters.....	8
Replacing the Motor Assembly .....	8
Replacing the Gears.....	9
Replacing the Transducer.....	9
Servicing the Fluid Section .....	10
<b>Troubleshooting</b> .....	<b>12</b>
<b>Parts List</b> .....	<b>18</b>
Main Assembly.....	18
Drive Assembly .....	19
Suction Set Assembly (Low Boy) .....	19
Labels .....	19
Fluid Section Assembly .....	20
Upright Cart Assembly.....	21
Filter Assembly .....	21
Pressure Control Assembly .....	22
Low Boy Cart Assembly.....	22
PRIME/SPRAY Assembly .....	23
Electrical Schematic .....	23
Accessories .....	23
<b>Limited Warranty</b> .....	<b>24</b>

## Safety Precautions

This manual contains information that must be read and understood before using the equipment. When you come to an area that has one of the following symbols, pay particular attention and make certain to heed the safeguard.



This symbol indicates a potential hazard that may cause serious injury or loss of life. Important safety information will follow.



This symbol indicates a potential hazard to you or to the equipment. Important information that tells how to prevent damage to the equipment or how to avoid causes of minor injuries will follow.

**NOTE:** Notes give important information which should be given special attention.



**HAZARD: Injection injury - A high pressure fluid stream produced by this equipment can pierce the skin and underlying tissues, leading to serious injury and possible amputation. See a physician immediately.**

**DO NOT TREAT AN INJECTION INJURY AS A SIMPLE CUT! Injection can lead to amputation. See a physician immediately.**

**The maximum operating range of the sprayer is 3200 PSI/221BAR fluid pressure.**

### PREVENTION:

- NEVER aim the gun at any part of the body.

- NEVER allow any part of the body to touch the fluid stream. DO NOT allow body to touch a leak in the fluid hose.
- NEVER put hand in front of the gun. Gloves will not provide protection against an injection injury.
- ALWAYS lock gun trigger, shut pump off, and release all pressure before servicing, cleaning tip or guard, changing tip, or leaving unattended. Pressure will not be released by turning off the motor. The PRIME/SPRAY valve handle must be turned to PRIME to relieve the pressure. Refer to the PRESSURE RELIEF PRESSURE described in the pump manual.
- ALWAYS keep tip guard in place while spraying. The tip guard provides some protection but is mainly a warning device.
- ALWAYS remove the spray tip before flushing or cleaning the system.
- Paint hose can develop leaks from wear, kinking and abuse. A leak can inject material into the skin. Inspect the hose before each use.
- NEVER use a spray gun without a working trigger lock and trigger guard in place.
- All accessories must be rated at or above 3200 PSI/221 BAR. This includes spray tips, guns, extensions, and hose.

### NOTE TO PHYSICIAN:

**Injection into the skin is a traumatic injury. It is important to treat the injury as soon as possible. DO NOT delay treatment to research toxicity. Toxicity is a concern with some coatings injected directly into the blood stream. Consultation with a plastic surgeon or reconstructive hand surgeon may be advisable.**

**HAZARD: EXPLOSION AND FIRE - Solvent and paint fumes can explode or ignite. Severe injury and/or property damage can occur.**

### PREVENTION:

- Provide extensive exhaust and fresh air introduction to keep the air within the spray area free from accumulation of flammable vapors.
- Avoid all ignition sources such as static electricity sparks, electrical appliances, flames, pilot lights, hot objects, and sparks from connecting and disconnecting power cords or working light switches.
- Do not smoke in spray area.
- Fire extinguisher must be present and in good working order.
- Place pump at least 20 feet (6.1 m) from the spray object in a well ventilated area (add more hose if necessary). Flammable vapors are often heavier than air. Floor area must be extremely well ventilated. The pump contains arcing parts that emit sparks and can ignite vapors.
- The equipment and objects in and around the spray area must be properly grounded to prevent static sparks.
- Use only conductive or grounded high-pressure fluid hose. Gun must be grounded through hose connections.
- Power cord must be connected to a grounded circuit.
- Always flush unit into separate metal container, at low pump pressure, with spray tip removed. Hold gun firmly against side of container to ground container and prevent static sparks.
- Follow material and solvent manufacturer's warnings and instructions.
- Use extreme caution when using materials with a flashpoint below 70° F (21° C). Flashpoint is the temperature at which a fluid can produce enough vapors to ignite.
- Plastic can cause static sparks. Never hang plastic to enclose spray area. Do not use plastic drop cloths when spraying flammable materials.
- Use lowest possible pressure to flush equipment.

## GAS ENGINE (WHERE APPLICABLE)

Always place sprayer outside of structure in fresh air. Keep all solvents away from engine exhaust. Never fill fuel tank with a running or hot engine. Hot surface can ignite spilled fuel. Always attach ground wire from pump to a grounded object. Refer to engine owner's manual for complete safety information.

**HAZARD: EXPLOSION HAZARD DUE TO INCOMPATIBLE MATERIALS - will cause severe injury or property damage.**

### PREVENTION:

- Do not use materials containing bleach or chlorine.
- Do not use halogenated hydrocarbon solvents such as bleach, mildewcide, methylene chloride and 1,1,1 - trichloroethane. They are not compatible with aluminum.
- Contact your coating supplier about the compatibility of material with aluminum.

**HAZARD: HAZARDOUS VAPORS - Paints, solvents, insecticides, and other materials can be harmful if inhaled or come in contact with body. Vapors can cause severe nausea, fainting, or poisoning.**

### PREVENTION:

- Use a respirator or mask if vapors can be inhaled. Read all instructions supplied with the mask to be sure it will provide the necessary protection.
- Wear protective eyewear.
- Wear protective clothing as required by coating manufacturer.

**HAZARD: GENERAL - Can cause severe injury or property damage.**

### PREVENTION:

- Read all instructions and safety precautions before operating equipment.
- Follow all appropriate local, state, and national codes governing ventilation, fire prevention, and operation.
- The United States Government Safety Standards have been adopted under the Occupational Safety and Health Act (OSHA). These standards, particularly part 1910 of the General Standards and part 1926 of the Construction Standards, should be consulted.
- Use only manufacturer authorized parts. User assumes all risks and liabilities when using parts that do not meet the minimum specifications and safety devices of the pump manufacturer.
- Before each use, check all hoses for cuts, leaks, abrasion or bulging of cover. Check for damage or movement of couplings. Immediately replace hose if any of those conditions exist. Never repair a paint hose. Replace with a grounded high-pressure hose.
- All hoses, swivels, guns, and accessories must be pressure rated at or above 3200PSI/221 BAR.
- Do not spray outdoors on windy days.
- Wear clothing to keep paint off skin and hair.
- Always unplug cord from outlet before working on equipment.

## Grounding Instructions

This product must be grounded. In the event of an electrical short circuit, grounding reduces the risk of electric shock by providing an escape wire for the electric current. This product is equipped with a cord having a grounding wire with an appropriate grounding plug. The plug must be plugged into an outlet that is properly installed and grounded in accordance with all local codes and ordinances.

**DANGER** — Improper installation of the grounding plug can result in a risk of electric shock. If repair or replacement of the cord or plug is necessary, do not connect the green grounding wire to either flat blade terminal. The wire with insulation having a green outer surface with or without yellow stripes is the grounding wire and must be connected to the grounding pin.

Check with a qualified electrician or serviceman if the grounding instructions are not completely understood, or if you are in doubt as to whether the product is properly grounded. Do not modify the plug provided. If the plug will not fit the outlet, have the proper outlet installed by a qualified electrician.

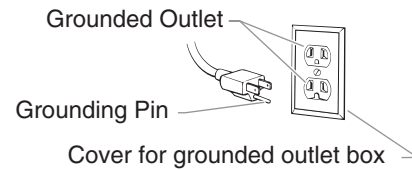

**CAUTION**

Use only a 3-wire extension cord that has a 3-blade grounding plug and a 3-slot receptacle that will accept the plug on the product. Make sure your extension cord is in good condition. When using an extension cord, be sure to use one heavy enough to carry the current your product will draw. An undersized cord will cause a drop in line voltage resulting in loss of power and overheating. A 12 gauge cord is recommended. If an extension cord is to be used outdoors, it must be marked with the suffix W-A after the cord type designation. For example, a designation of SJTW-A would indicate that the cord would be appropriate for outdoor use.

## General Description

This airless sprayer is a precision power tool used for spraying many types of materials. Read and follow this instruction manual carefully for proper operating instructions, maintenance, and safety information.

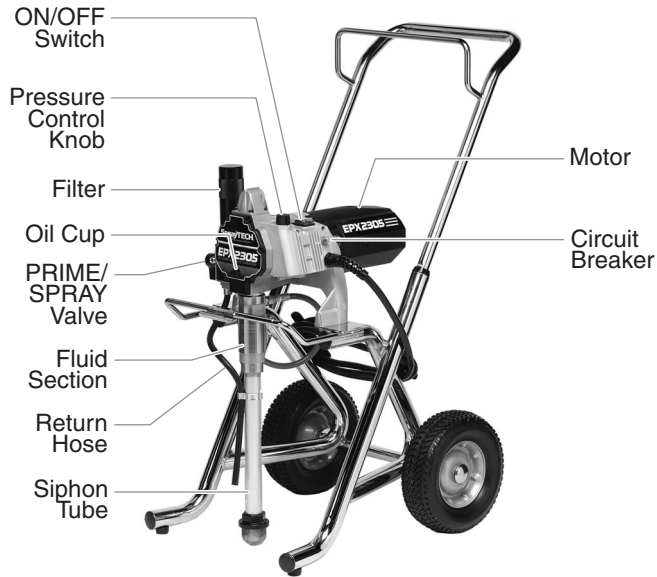

## Operation

### ⚠ WARNING

**This equipment produces a fluid stream at extremely high pressure. Read and understand the warnings in the Safety Precautions section at the front of this manual before operating this equipment.**

### Setup

Perform the following procedure before plugging in the power cord of an electric unit.

1. Ensure that the siphon tube/suction set and the return hose are attached and secure.
2. Using a wrench, attach a minimum of 50' of 1/4" nylon airless spray hose to the unit. Tighten securely.
3. Attach an airless spray gun to the spray hose. Using two wrenches (one on the gun and one on the hose), tighten securely.

**NOTE: Do not attach the tip to the spray gun yet. Remove the tip if it is already attached.**

### ⚠ WARNING

**Make sure all airless hoses and spray guns are electrically grounded and rated for at least 3200 psi (221 bar) fluid pressure.**

4. Make sure the pressure control knob is turned fully counterclockwise to its lowest pressure setting.
5. Fill the oil cup with approximately one tablespoon of separating oil (P/N 0279920).

### ⚠ CAUTION

**Never operate unit for more than ten seconds without fluid. Operating this unit without fluid will cause unnecessary wear to the packings.**

6. Make sure the electrical service is 120V, 15 amp minimum.
7. Plug the power cord into a properly grounded outlet at least 25' from the spray area.

### ⚠ CAUTION

**Always use a minimum 12 gauge, three-wire extension cord with a grounded plug. Never remove the third prong or use an adapter.**

### Preparing a New Sprayer

If this unit is new, it is shipped with test fluid in the fluid section to prevent corrosion during shipment and storage. This fluid must be thoroughly cleaned out of the system with mineral spirits before you begin spraying.

### ⚠ CAUTION

**Always keep the trigger lock on the spray gun in the locked position while preparing the system.**

1. Place the siphon tube into a container of mineral spirits.
2. Place the return hose into a metal waste container.
3. Set the pressure to minimum by turning the pressure control knob fully counterclockwise.

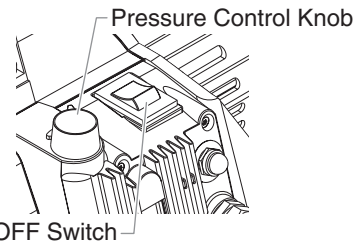

4. Move the PRIME/SPRAY valve down to the PRIME position.
5. Turn the unit on by moving the ON/OFF switch to the ON position.
6. Allow the sprayer to run for 15–30 seconds to flush the test fluid out through the return hose and into the waste container.
7. Turn the unit off by moving the ON/OFF switch to the OFF position.

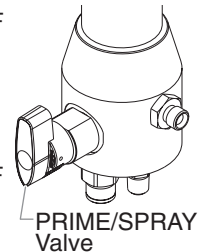

### Preparing to Paint

Before painting, it is important to make sure that the fluid in the system is compatible with the paint that is going to be used.

**NOTE: Incompatible fluids and paint may cause the valves to become stuck closed, which would require disassembly and cleaning of the sprayer's fluid section.**

### ⚠ CAUTION

**Always keep the trigger lock on the spray gun in the locked position while preparing the system.**

1. Place the siphon tube into a container of the appropriate solvent. Examples of the appropriate solvent are water for latex paint or mineral spirits for oil-based paints.
2. Place the return hose into a metal waste container.
3. Set the pressure to minimum by turning the pressure control knob fully counterclockwise.
4. Move the PRIME/SPRAY valve down to the PRIME position.
5. Turn the unit on by moving the ON/OFF switch to the ON position.
6. Allow the sprayer to run for 15–30 seconds to flush the old solvent out through the return hose and into the metal waste container.
7. Turn the unit off by moving the ON/OFF switch to the OFF position.

**NOTE: Make sure that the spray gun does not have a tip or tip guard installed.**

8. Move the PRIME/SPRAY valve up to the SPRAY position.
9. Turn the unit on.
10. Unlock the gun by turning the gun trigger lock to the unlocked position.

### ⚠ WARNING

**Ground the gun by holding it against the edge of the metal container while flushing. Failure to do so may lead to a static electric discharge, which may cause a fire.**

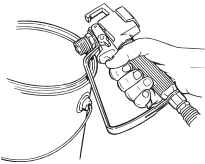

11. Trigger the gun into the metal waste container until the old solvent is gone and fresh solvent is coming out of the gun.
12. Lock the gun by turning the gun trigger lock to the locked position.
13. Set down the gun and increase the pressure by turning the pressure control knob slowly clockwise.
14. Check the entire system for leaks. If leaks occur, turn the unit off and follow the "Pressure Relief Procedure" in this manual before tightening any fittings or hoses.
15. Follow the "Pressure Relief Procedure" in this manual before changing from solvent to paint.

### ⚠ WARNING

**Be sure to follow the pressure relief procedure when shutting the unit down for any purpose, including servicing or adjusting any part of the spray system, changing or cleaning spray tips, or preparing for cleanup.**

## Painting

1. Place the siphon tube into a container of paint.
2. Place the return hose into a metal waste container.
3. Set the pressure to minimum by turning the pressure control knob fully counterclockwise.

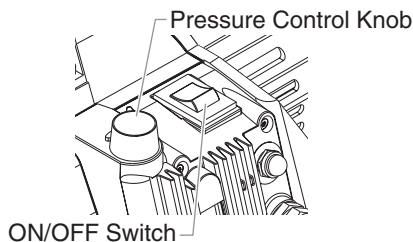

4. Move the PRIME/SPRAY valve down to the PRIME position.
5. Turn the unit on by moving the ON/OFF switch to the ON position.
6. Allow the sprayer to run until paint is coming through the return hose into the metal waste container.
7. Turn the unit off by moving the ON/OFF switch to the OFF position.
8. Remove the return hose from the waste container and place it in its operating position above the container of paint.
9. Move the PRIME/SPRAY valve up to the SPRAY position.
10. Turn the unit on.
11. Unlock the gun by turning the gun trigger lock to the unlocked position.

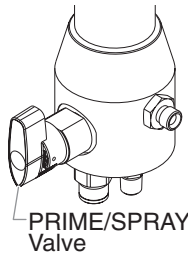

### ⚠ WARNING

**Ground the gun by holding it against the edge of the metal container while flushing. Failure to do so may lead to a static electric discharge, which may cause a fire.**

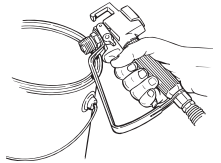

12. Trigger the gun into the metal waste container until all air and solvent is flushed from the spray hose and paint is flowing freely from the gun.
13. Lock the gun by turning the gun trigger lock to the locked position.
14. Turn the unit off.
15. Attach tip guard and tip to the gun as instructed by the tip guard or tip manuals.

### ⚠ WARNING

**POSSIBLE INJECTION HAZARD. Do not spray without the tip guard in place. Never trigger the gun unless the tip is in either the spray or the unclog position. Always engage the gun trigger lock before removing, replacing or cleaning tip.**

16. Turn the unit on.
17. Increase the pressure by turning the pressure control knob slowly clockwise and test the spray pattern on a piece of cardboard. Adjust the pressure control knob until the spray from the gun is completely atomized. Try to keep the pressure control knob at the lowest setting that maintains good atomization.

**NOTE: Turning the pressure up higher than needed to atomize the paint will cause premature tip wear and additional overspray.**

## Pressure Relief Procedure

### ⚠ WARNING

**Be sure to follow the pressure relief procedure when shutting the unit down for any purpose, including servicing or adjusting any part of the spray system, changing or cleaning spray tips, or preparing for cleanup.**

1. Lock the gun by turning the gun trigger lock to the locked position.
2. Turn the unit off by moving the ON/OFF switch to the OFF position.
3. Set the pressure to minimum by turning the pressure control knob fully counterclockwise.
4. Unlock the gun by turning the gun trigger lock to the unlocked position.
5. Hold the metal part of the gun firmly to the side of a metal container to ground the gun and avoid a build up of static electricity.
6. Trigger the gun to remove any pressure that may still be in the hose.
7. Lock the gun by turning the gun trigger lock to the locked position.
8. Move the PRIME/SPRAY valve down to the PRIME position.

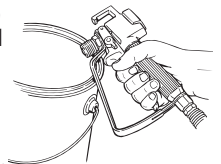

# Spraying

**NOTE: When spraying block filler, mastics or high solid coating, remove the gun filter and high pressure filter screens.**

## Spraying Technique

The key to a good paint job is an even coating over the entire surface. This is done by using even strokes. Keep your arm moving at a constant speed and keep the spray gun at a constant distance from the surface. The best spraying distance is 10 to 12 inches between the spray tip and the surface.

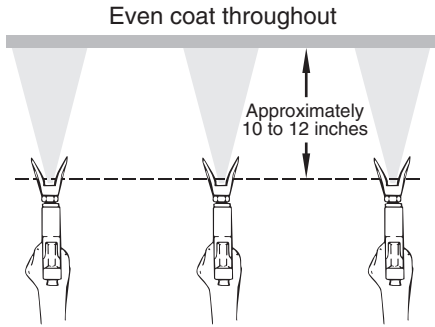

Keep stroke smooth and at an even speed.

Keep the spray gun at right angles to the surface. This means moving your entire arm back and forth rather than just flexing your wrist.

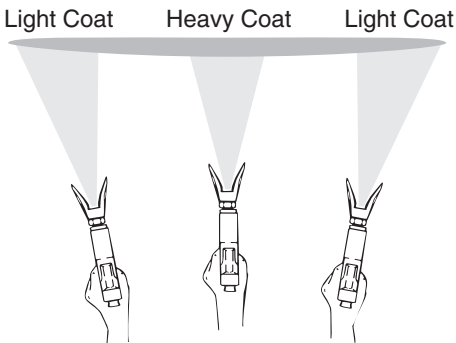

Do not flex wrist while spraying.

Keep the spray gun perpendicular to the surface, otherwise one end of the pattern will be thicker than the other.

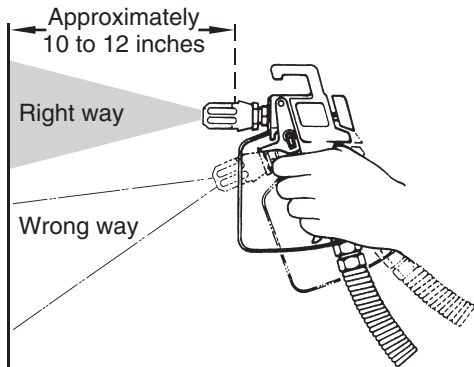

The spray gun should be triggered by turning it on and off with each stroke. This will save paint and avoid paint buildup at the end of the stroke. Do not trigger the gun during the middle of a stroke. This will result in an uneven spray and spotty coverage.

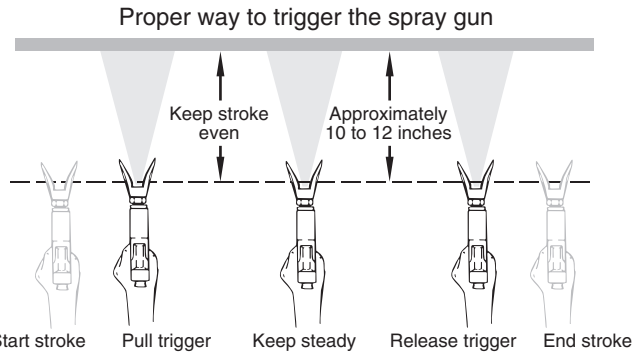

Overlap each stroke by about 30%. This will ensure an even coating.

When you stop painting, lock the gun trigger lock, turn the pressure control knob counterclockwise to its lowest setting and set the PRIME/SPRAY valve to PRIME. Turn the ON/OFF switch to the OFF position and unplug the sprayer.

## Practice

1. Be sure that the paint hose is free of kinks and clear of objects with sharp cutting edges.
2. Turn the pressure control knob counterclockwise to its lowest setting.
3. Move the PRIME/SPRAY valve up to the SPRAY position.
4. Turn the pressure control knob clockwise to its highest setting. The paint hose should stiffen as paint begins to flow through it.
5. Unlock the gun trigger lock.
6. Trigger the spray gun to bleed air out of the hose.
7. When paint reaches the spray tip, spray a test area to check the spray pattern.
8. Use the lowest pressure setting necessary to get a good spray pattern. If the pressure is set too high, the spray pattern will be too light. If the pressure is set too low, tailing will appear or the paint will spatter out in gobs rather than in a fine spray.

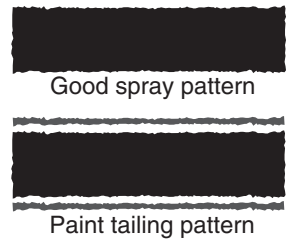
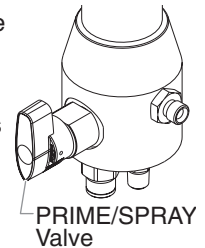

## Cleanup



### Special cleanup instructions for use with flammable solvents:

- Always flush spray gun preferably outside and at least one hose length from spray pump.
- If collecting flushed solvents in a one gallon metal container, place it into an empty five gallon container, then flush solvents.
- Area must be free of flammable vapors.
- Follow all cleanup instructions.



The sprayer, hose, and gun should be cleaned thoroughly after daily use. Failure to do so permits material to build up, seriously affecting the performance of the unit.

## ⚠️ WARNING

Always spray at minimum pressure with the gun nozzle tip removed when using mineral spirits or any other solvent to clean the sprayer, hose, or gun. Static electricity buildup may result in a fire or explosion in the presence of flammable vapors.

1. Follow the "Pressure Relief Procedure" found in the Operation section of this manual.
2. Remove the gun tip and tip guard and clean with a brush using the appropriate solvent.
3. Place the siphon tube into a container of the appropriate solvent. Examples of the appropriate solvent are water for latex paint or mineral spirits for oil-based paints.
4. Place the return hose into a metal waste container.
5. Set the pressure to minimum by turning the pressure control knob fully counterclockwise.
6. Move the PRIME/SPRAY valve down to its PRIME position.
7. Turn the unit on by moving the ON/OFF switch to the ON position.
8. Allow the solvent to circulate through the unit and flush the paint out of the return hose into the metal waste container.
9. Turn the unit off by moving the ON/OFF switch to the OFF position.
10. Move the PRIME/SPRAY valve up to its SPRAY position.
11. Turn the unit on.

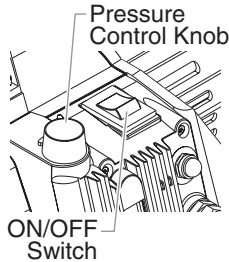

## ⚠️ WARNING

Ground the gun by holding it against the edge of the metal container while flushing. Failure to do so may lead to a static electric discharge, which may cause a fire.

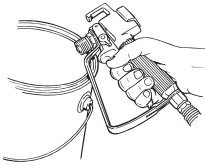

12. Trigger the gun into the metal waste container until the paint is flushed out of the hose and solvent is coming out of the gun.
13. Continue to trigger the spray gun into the waste container until the solvent coming out of the gun is clean.

**NOTE: For long-term or cold weather storage, pump mineral spirits through the entire system.**

14. Follow the "Pressure Relief Procedure" found in the Operation section of this manual.
15. Unplug the unit and store in a clean, dry area.

## ⚠️ CAUTION

Do not store the unit under pressure.

### Cleaning the Spray Tip

1. Flush the gun with solvent immediately after the work is completed.
2. Oil the sliding pins to prevent them from seizing up.

Should the spray tip become clogged, reverse the spray tip with the lever and pull the trigger. Once the obstruction comes out of the spray tip, release the trigger, reverse the spray tip back to the spray pattern setting, and resume spraying.



## ⚠️ WARNING

Do not attempt to clean the tip with your finger. Do not use a needle or other sharp pointed instrument to clean the tip. The hard tungsten carbide is brittle and can be chipped.

## Maintenance

## ⚠️ WARNING

Before proceeding, follow the Pressure Relief Procedure outlined previously in this manual. Additionally, follow all other warnings to reduce the risk of an injection injury, injury from moving parts or electric shock. Always unplug the sprayer before servicing!

### General Repair and Service Notes

1. Before repairing any part of the sprayer, read the instructions carefully, including all warnings.

## ⚠️ CAUTION

Never pull on a wire to disconnect it. Pulling on a wire could loosen the connector from the wire.

2. Test your repair before regular operation of the sprayer to be sure that the problem is corrected. If the sprayer does not operate properly, review the repair procedure to determine if everything was done correctly. Refer to the Troubleshooting section to help identify other possible problems.
3. Make certain that the service area is well ventilated in case solvents are used during cleaning. Always wear protective eyewear while servicing. Additional protective equipment may be required depending on the type of cleaning solvent. Always contact the supplier of solvents for recommendations.
4. If you have any further questions concerning your SprayTECH Airless Sprayer, call SprayTECH:

Technical Service.....1-800-292-4637

Fax .....1-800-525-9501

### Replacing the PRIME/SPRAY Valve

Perform the following procedure using PRIME/SPRAY valve replacement kit P/N 0507690.

1. Drive the groove pin out of the valve handle.
2. Remove the valve handle and the cam base.
3. Using a wrench, loosen and remove the valve housing assembly.
4. Make sure the gasket is in place and thread the new valve housing assembly into the filter block. Tighten securely with a wrench.
5. Place the cam base over the valve housing assembly. Lubricate the cam base with grease and line up the cam with the filter block using the dowel pin.
6. Line up the hole on the valve stem with the hole in the valve handle.
7. Insert the groove pin into the valve handle and through the valve stem to secure the valve handle in position.

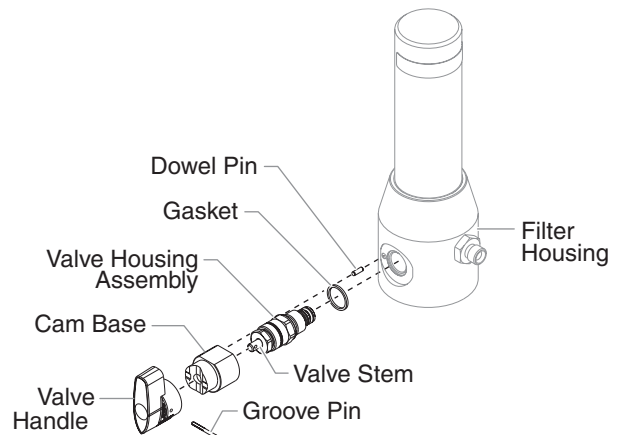

## Replacing the Filters

### Pump Filter

1. Loosen and remove the filter body by hand.
2. Slip the filter off of the core spring.
3. Inspect the filter. Based on inspection, clean or replace the filter.
4. Inspect the o-ring. Based on inspection, clean or replace the o-ring.
5. Slide the new or cleaned filter over the core spring. Push the filter into the center of the filter housing.
6. Slide the filter body over the filter and thread it into the filter housing until secure.

**NOTE: The filter body should be hand-tightened, but make sure it is seated fully into the filter housing.**

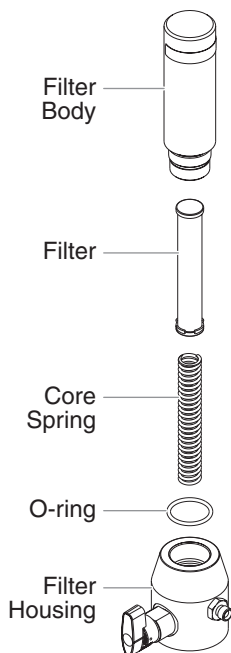

### Gun Filter

1. Pull the trigger guard forward so that it comes loose from the handle.
2. Unscrew the handle from the housing and remove the old filter.
3. Slide the new filter, taper end first, into the gun housing.
4. Replace the handle, washer and spring. Screw the handle into the housing until hand-tight. Replace the trigger guard.

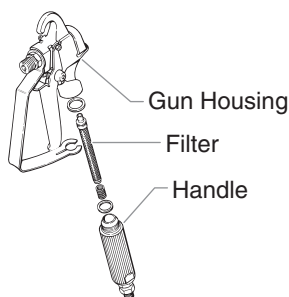

### Choosing the Correct Spray Gun Filter

Use the proper gun filter based on the type of material being applied as shown below.

Part no.	Application	Filter type	Mesh number	Color of Filter body
0089960	Synthetic resin, enamels, clean varnishes, stains azures	Extrafine	0.084 mm	red
0089959	Base coat enamels, primer enamels, fillers, marking paints, textured enamels	Fine	0.140 mm	yellow
0089958	Emulsions, latex paints, acrylic paints	Medium	0.315 mm	white
0089957	Filler paints, large area surfaces	Coarse	0.560 mm	green

**NOTE: For more detail, part number information, and assembly drawings at larger scale, please see the G-10 2-Finger/4-Finger Airless Spray Gun Owner's Manuals (P/N 0297076 or P/N 0508832).**

## Replacing the Motor Assembly

1. Perform the Pressure Relief Procedure and unplug the unit.
2. For Upright cart units, remove the return hose from the clamp on the siphon tube. Unscrew the siphon tube from the inlet valve housing.
3. For Low Boy cart units, remove the retaining ring from the bottom of the inlet valve housing using a snap ring pliers. Remove the suction set assembly.
4. Loosen and remove the high-pressure hose from the nipple on the back of the fluid section and from the bottom of the filter assembly.
5. Loosen and remove the six front cover screws. Remove the front cover.
6. Loosen and remove the three motor shroud screws. Remove the motor shroud.
7. Slide the baffle off of the end of the motor.

**NOTE: Before removing the baffle, note the location of the baffle on the motor so it can be positioned in the same spot during reassembly.**

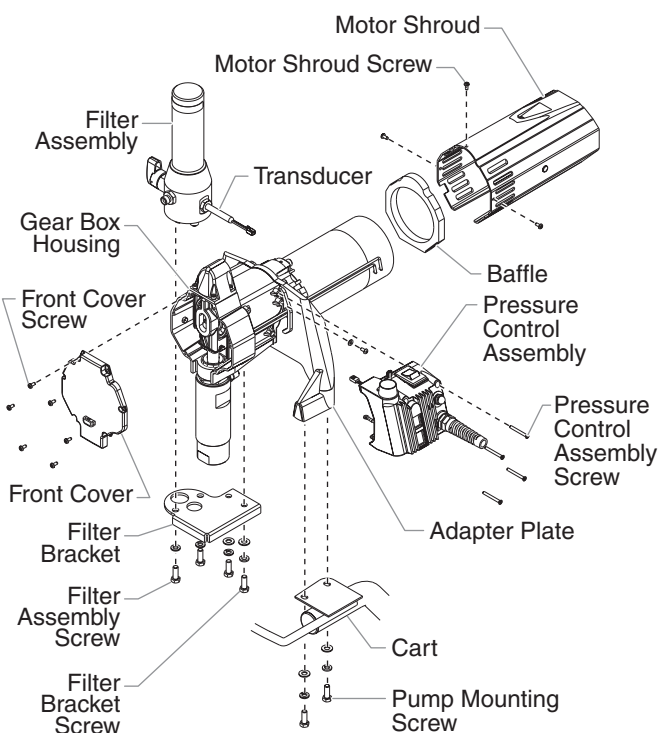

8. Loosen and remove the four pressure control assembly screws. Carefully pull the pressure control assembly off of the gear box housing.
9. At the pressure control assembly:
  - a. Disconnect the red wire and black wire coming from the motor.
  - b. Disconnect the phone jack-style connector on the black wire coming from the transducer.
10. Set aside the pressure control assembly.
11. Loosen and remove the two filter assembly screws. Lift the filter assembly off of the filter bracket.
12. Loosen and remove the transducer from the filter housing. Do not pull the transducer wire out of the gear box housing.
13. Loosen and remove the two filter bracket screws. Remove the filter bracket from the adapter plate.
14. Loosen and remove the four pump mounting screws. Lift the pump off of the cart and place face down on a work bench.



- Using a hex wrench, loosen and remove the three adapter plate screws and flat washers that hold the motor/adapter plate assembly to the gear box housing. Pull the motor/adapter plate assembly off of the gear box housing.

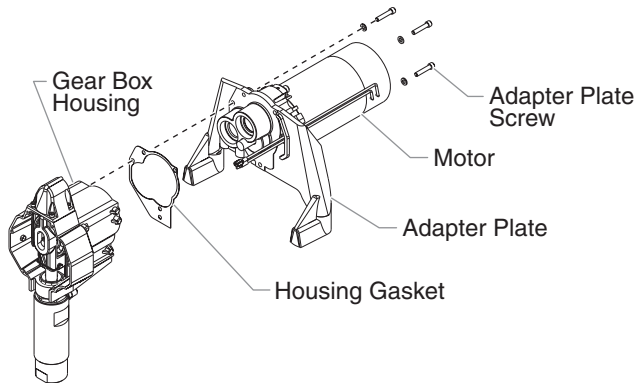

- With the motor removed, inspect the gears in the gear box housing for damage or excessive wear. Replace the gears, if necessary.
- Align the two dowel pins on the gear box housing with the holes on the new motor/adapter plate assembly and install the motor/adapter plate assembly onto the gear box housing. Make sure the housing gasket is positioned properly.
- Apply blue Loctite to the three adapter plate screws.
- Secure the motor/adapter plate assembly to the gear box housing with the three adapter plate screws and washers. Torque to 156–180 in./lbs.
- Slide the baffle over the end of the motor and position it in the location noted during disassembly.
- Position the pump on the cart. Secure the pump to the cart using the four pump mounting screws, lock washers, and flat washers.
- Position the filter bracket on the adapter plate. Secure the filter bracket with the two filter bracket screws, lock washers, and flat washers.
- Thread the transducer into the filter housing. Tighten securely.
- Position the filter assembly on the filter bracket. Secure the filter using the two filter assembly screws and lock washers.
- Reconnect the phone jack-style connector on the black wire from the transducer to the socket on the pressure control assembly.
- Connect the red wire from the motor to the red wire on the rectifier in the pressure control assembly (refer to the electrical schematic in the Parts List section of this manual).
- Connect the black wire from the motor to the black wire on the rectifier in the pressure control assembly (refer to the electrical schematic in the Parts List section of this manual).
- Position the pressure control assembly on the gear box housing. Secure the pressure control assembly with the four pressure control assembly screws.
- Attach the high-pressure hose to the nipple on the back of the fluid section and to the bottom of the filter assembly. Tighten with a wrench. Do not kink the hose.
- Slide the motor shroud over the motor and the baffle. Make sure the baffle stays in position.
- Secure the motor shroud to the adapter plate with the three motor shroud screws.
- Place the front cover on the gear box housing and secure in position using the six front cover screws.
- For Upright cart units, thread the siphon tube into the inlet valve and tighten securely. Make sure to wrap the threads on the down tube with Teflon tape before assembly. Replace the return hose into the clamp on the siphon tube.
- For Low Boy cart units, insert the elbow on the suction set assembly into the bottom of the inlet valve housing. Push the retaining ring up into the groove inside the inlet valve housing to secure the suction set assembly in position.

## Replacing the Gears

- Perform the Pressure Relief Procedure and unplug the unit.
- Perform steps 2–15 of the “Replacing the Motor Assembly” procedure in this section.
- Inspect the armature gear on the end of the motor for damage or excessive wear. If this gear is completely worn out, replace the motor.
- Remove and inspect the 1st stage gear set for damage or excessive wear. Replace, if necessary.
- Inspect the output gear assembly for damage or excessive wear. If damaged or worn, replace the front gear box assembly.

**NOTE: Clean and refill the gear box cavity up to the rear face of each gear with grease (P/N 9870307).**

- Position the housing gasket on the two dowel pins on the gear box housing.
- Perform steps 17–34 of the “Replacing the Motor Assembly” procedure in this section.

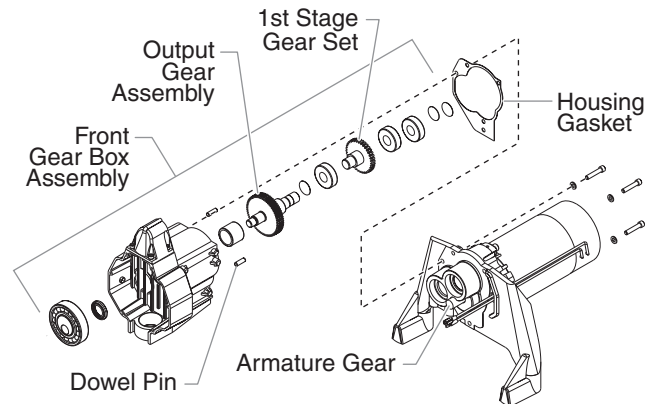

**NOTE: The front gear box assembly does not include the 1st stage gear set.**

## Replacing the Transducer

- Perform the Pressure Relief Procedure and unplug the unit.
- Loosen and remove the four pressure control assembly screws. Carefully pull the pressure control assembly off of the gear box housing.
- At the pressure control assembly, disconnect the phone jack-style connector on the black wire coming from the transducer.
- Set aside the pressure control assembly.
- Loosen and remove the two filter assembly screws. Lift the filter assembly off of the filter bracket.
- Using a wrench, loosen and remove the transducer from the filter housing. Carefully thread the transducer wire out through the hole in the gear box housing.
- Thread the new transducer wire through the hole in the gear box housing and over to the pressure control assembly.
- Thread the new transducer into the filter housing and tighten securely with a wrench.

**NOTE: Make sure the o-ring on the transducer is in place before threading the transducer into the filter housing.**

- Position the filter assembly on the filter bracket. Secure the filter using the two filter assembly screws and lock washers.
- Reconnect the phone jack-style connector on the black wire from the transducer to the socket on the pressure control assembly.
- Position the pressure control assembly on the gear box housing. Secure the pressure control assembly with the four pressure control assembly screws.

## Servicing the Fluid Section

Use the following procedures to service the valves and repack the fluid section.

1. Perform the Pressure Relief Procedure and unplug the unit.

### ⚠ WARNING

**Before proceeding, follow the Pressure Relief Procedure outlined previously in this manual. Additionally, follow all other warnings to reduce the risk of an injection injury, injury from moving parts or electric shock. Always unplug the sprayer before servicing!**

2. For Upright cart units, remove the return hose from the clamp on the siphon tube. Unscrew the siphon tube from the inlet valve housing.
3. For Low Boy cart units, remove the retaining ring from the bottom of the inlet valve housing using a snap ring pliers. Remove the suction set assembly.
4. Loosen and remove the high-pressure hose from the nipple on the back of the cylinder of the fluid section.
5. Loosen and remove the six front cover screws. Remove the front cover.
6. Pull the retaining clip from the yoke and connecting pin.
7. Push the connecting pin out of the piston and yoke. Use the short end of a hex wrench if necessary.
8. Using a wrench, turn the jam nut counterclockwise to loosen it from the gear box housing.
9. Turn the fluid section counterclockwise to remove it from the gear box housing.
10. Place the fluid section cylinder upright in a vise by clamping on the wrench flats.

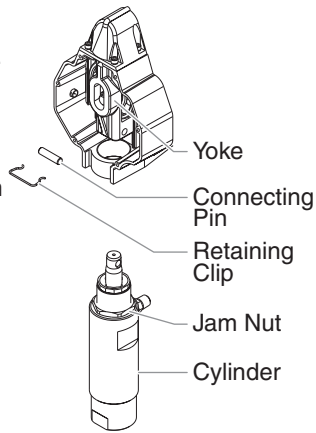

**NOTE: Do not over-tighten the vise. Damage to the cylinder may occur.**

11. Loosen and remove the inlet valve housing from the cylinder.
12. Remove the inlet valve cage, inlet valve ball, inlet valve seat, and o-ring from the inlet valve.
13. Clean out any debris in the inlet valve housing and examine the housing and the inlet valve seat. If the seat is damaged, reverse or replace the seat.

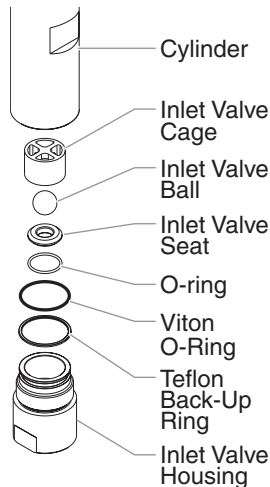

14. Using a wrench, remove the upper seal retainer.
15. Remove the support washer from inside the bottom of the cylinder.
16. Slide the piston rod out through the bottom of the cylinder.
17. Inspect the piston rod for wear and replace if necessary.
18. Remove the upper support ring and upper packing assembly from the top of the cylinder.
19. Remove the lower support ring and lower packing assembly from the bottom of the cylinder.

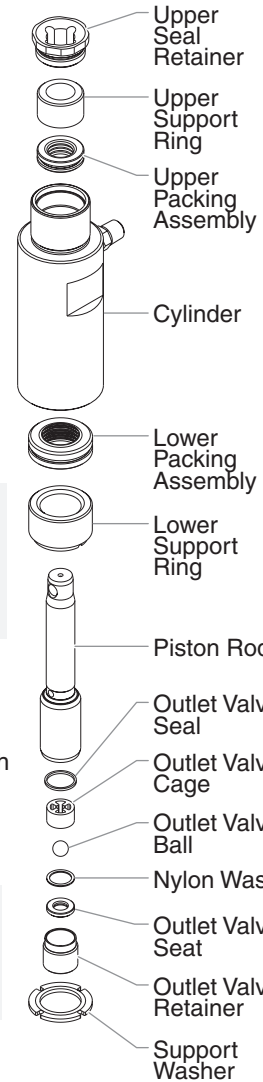

**NOTE: Be careful not to scratch, score, or otherwise damage the cylinder during removal of the packing assemblies.**

20. Remove the cylinder from the vise.
21. Insert the connection pin through the hole at the top of the piston rod and clamp each end of the connection pin in the vise. This will hold the piston rod in position for disassembly.

**NOTE: Do not clamp the piston rod directly in the vise. Damage to the piston rod will occur.**

22. Using a 3/8" hex wrench, loosen and remove the outlet valve retainer from the piston rod.
23. Remove the outlet valve seal, outlet valve cage, outlet valve ball, nylon washer, and outlet valve seat from the outlet valve retainer.
24. Clean out any debris and examine the retainer and outlet valve seat. If the seat is damaged, reverse or replace the seat.
25. Clean and inspect the outlet valve cage and outlet valve ball. Replace if they are worn or damaged.
26. Reassemble the outlet valve assembly into the piston rod in the reverse order of how it was disassembled. Torque the outlet valve retainer to 12 ft. lbs.
27. Remove the piston rod from the vise.
28. Clean the cylinder. Inspect the cylinder for damage and replace if necessary.
29. Place the cylinder upright in a vise by clamping on the wrench flats.
30. Locate the new upper and lower packing assemblies and pack the areas between the packing lips with grease. Lubricate the o-rings on the exterior of the packings with grease.

31. Insert the upper packing assembly into the top of the cylinder with the large beveled edge facing down.
32. Insert the upper support ring on top of the upper packing assembly.

Install upper packing with large beveled edge facing down.



33. Thread the upper seal retainer into the cylinder and torque to 25-30 ft. lbs.
34. Rotate the cylinder in the vise so that the bottom end is facing up.
35. Pre-form the lower packing using the lower packing sizing tool (included in the repacking kit).
36. Insert the lower packing assembly partially into the bottom of the cylinder with the large beveled edge facing toward the cylinder (beveled edge will be facing up when the cylinder is upright).
37. Push the lower packing assembly into position using the lower packing insertion tool (see Fluid Section Assembly parts list for lower packing insertion tool P/N).
38. Place the piston insertion tool (included in the repacking kit) over the top of the piston rod.
39. Insert the piston rod into the bottom of the cylinder, through the lower packing assembly, through the upper packing assembly, and out through the upper seal retainer.

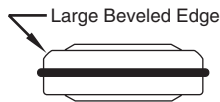

Install lower packing so large beveled edge will be facing up when the cylinder is upright.

**NOTE: When repacking the fluid section, make sure the raised lip on the bottom of the lower packing assembly is fully outside the packing around the piston rod after insertion of the piston rod.**

40. Turn the jam nut counterclockwise until it is flush against the top of the cylinder.
41. Lubricate the threads on the cylinder with anti-seize compound. Remove the cylinder from the vise.
42. Thread the cylinder into the gear box housing, turning clockwise. When the connecting pin hole on the piston rod lines up with the hole in the yoke, insert the connecting pin.
43. Snap the retaining clip around the connecting pin and yoke.
44. Continue to turn the cylinder clockwise until the jam nut is flush against the gear box housing.

**NOTE: If the nipple on the cylinder does not face the back of the unit, turn the cylinder counterclockwise until the nipple faces the back of the unit. Do not turn the cylinder more than one full turn.**

45. Once the nipple is positioned, turn the jam nut clockwise until it contacts the gear box housing.
46. Tighten the jam nut with a wrench to tighten it against the gear box housing.
47. Attach the high-pressure hose to the nipple on the back of the cylinder and tighten with a wrench. Do not kink the hose.
48. Insert the lower support ring into the bottom of the cylinder.
49. Insert the support washer into the bottom of the cylinder.
50. Making sure that the Viton o-ring and Teflon back-up ring are lubricated and in place, reassemble the inlet valve assembly and thread it into the cylinder. Tighten the inlet valve housing until the o-ring engages, then continue to tighten until snug. Once snug, tighten an additional 1/8–1/4 turn.
51. For Upright cart units, thread the siphon tube into the inlet valve and tighten securely. Make sure to wrap the threads on the down tube with Teflon tape before assembly. Replace the return hose into the clamp on the siphon tube.
52. For Low Boy cart units, insert the elbow on the suction set assembly into the bottom of the inlet valve housing. Push the retaining ring up into the groove inside the inlet valve housing to secure the suction set assembly in position.

53. Place the front cover on the gear box housing and secure in position using the six front cover screws.
54. Turn on the sprayer by following the procedure in the "Operation" section of this manual and check for leaks.

**NOTE: Repacking kit P/N 0507929 is available. For best results use all parts supplied in this kit.**

# Troubleshooting

## Problem

The unit will not run.

## Cause

1. The unit is not plugged in.
2. Tripped breaker.
3. The pressure is set too low (pressure control knob set at minimum setting does not supply power to unit).
4. Faulty or loose wiring.
5. Excessive motor temperature.

## Solution

1. Plug the unit in.
2. Reset the breaker.
3. Turn the pressure control knob clockwise to supply power to the unit and increase the pressure setting.
4. Inspect or take to a SprayTECH authorized service center.
5. Allow motor to cool.

The unit will not prime.

1. The PRIME/SPRAY valve is in the SPRAY position.
2. Air leak in the siphon tube/suction set.
3. The pump filter and/or inlet screen is clogged.
4. The siphon tube/suction set is clogged.

1. Rotate the PRIME/SPRAY valve clockwise to the PRIME position.
2. Check the siphon tube/suction set connection and tighten or re-tape the connection with Teflon tape.
3. Remove the pump filter element and clean. Remove the inlet screen and clean.
4. Remove the siphon tube/suction set and clean.

The unit will not build or maintain pressure.

1. The spray tip is worn.
2. The spray tip is too large.
3. The pressure control knob is not set properly.
4. The pump filter, gun filter, or inlet screen is clogged.
5. Material flows from the return hose when the PRIME/SPRAY valve is in the SPRAY position.
6. Air leak in the siphon tube/suction set.
7. There is external fluid leak.
8. There is an internal fluid section leak (packings are worn and/or dirty, valve balls are worn).
9. Worn valve seats
10. Motor powers but fails to rotate

1. Replace the spray tip following the instructions that came with the spray gun.
2. Replace the spray tip with a tip that has a smaller orifice following the instructions that came with the spray gun.
3. Turn the pressure control knob clockwise to increase the pressure setting.
4. Remove the pump filter element and clean. Remove the gun filter and clean. Remove the inlet screen and clean.
5. Clean or replace the PRIME/SPRAY valve.
6. Check the siphon tube/suction set connection and tighten or re-tape the connection with Teflon tape.
7. Check for external leaks at all connections. Tighten connections, if necessary.
8. Clean the valves and service the fluid section following the "Servicing the Fluid Section" procedure in the Maintenance section of this manual.
9. Reverse or replace the valve seats following the "Servicing the Fluid Section" procedure in the Maintenance section of this manual.
10. Take unit to a SprayTECH authorized service center.

Fluid leakage at the upper end of the fluid section.

1. The upper packings are worn.
2. The piston rod is worn.

1. Repack the pump following the "Servicing the Fluid Section" procedure in the Maintenance section of this manual.
2. Replace the piston rod following the "Servicing the Fluid Section" procedure in the Maintenance section of this manual.

# Troubleshooting

## Problem

Excessive surge at the spray gun.

## Cause

1. Wrong type of airless spray hose.
2. The spray tip worn or too large.
3. Excessive pressure.

## Solution

1. Replace hose with a minimum of 50' of 1/4" grounded textile braid airless paint spray hose.
2. Replace the spray tip following the instructions that came with the spray gun.
3. Rotate the pressure control knob counterclockwise to decrease spray pressure.

---

Poor spray pattern.

- 
1. The spray tip is too large for the material being used.
  2. Incorrect pressure setting.
  3. Insufficient fluid delivery.
  4. The material being sprayed is too viscous.

- 
1. Replace the spray tip with a new or smaller spray tip following the instructions that came with the spray gun.
  2. Rotate the pressure control knob to adjust the pressure for a proper spray pattern.
  3. Clean all screens and filters.
  4. Add solvent to the material according to the manufacturer's recommendations.

---

The unit lacks power.

- 
1. The pressure adjustment is too low.
  2. Improper voltage supply.

- 
1. Rotate the pressure control knob clockwise to increase the pressure setting.
  2. Reconnect the input voltage for 120V AC.

### Brushless motor system electrical troubleshooting

Symptom:	Cause:	
Motor does not run when pressure control is adjusted to maximum	Unit unplugged,	plug unit into power source.
	System is already pressurized,	release pressure.
	Faulty Pressure Transducer,	connect spare transducer to controller, see if unit runs.
	Faulty pressure control potentiometer,	connect spare pressure control potentiometer, see if unit runs.
	Faulty solid state relay,	measure voltage at input to controller (white leads), no voltage replace solid state relay.
Mechanical component failure, causing binding or excessive load	place an amp probe on white lead or connect ammeter in series with white lead on controller, if the current is high for 1 seconds then low for 4 seconds the controller detected excessive torque, check gear box, crank/slider, and fluid section components.	

### Brushed motor system with electronic control troubleshooting

Sypmtom:	Cause:	
Motor does not run when pressure control is adjusted to maximum	Unit unplugged,	plug unit into power source.
	System is already pressurized,	release pressure.
	Faulty Pressure Transducer,	connect spare transducer to controller, see if unit runs.
	Faulty pressure control potentiometer,	connect spare pressure control potentiometer, see if unit runs.
	Faulty controller	bypass controller by connecting line input to the rectifier AC input if motor runs replace controller, if motor does not run check motor brushes.
	Motor brushes worn	check and replace if necessary
	Faulty rectifier	check with DMM in diode mode remove rectifier from circuit connect DMM red lead to the black (motor lead) and the black DMM lead to the red (motor lead) measure voltage should be $>0.7$ and not show over limit

## Consignes de sécurité

Le présent manuel comprend des renseignements devant être lus attentivement avant toute utilisation de l'appareil. Lorsque l'un des symboles suivants apparaît, il est recommandé d'être particulièrement attentif et de tenir compte des mesures de sécurité indiquées.

### **⚠ AVERTISSEMENT**

Ce symbole indique un danger potentiel pouvant causer des blessures graves ou même mortelles. Des renseignements importants sur la sécurité sont également indiqués.

### **⚠ ATTENTION**

Ce symbole indique un danger potentiel pouvant causer des blessures corporelles ou des dommages à l'équipement. Des renseignements importants sur la façon de prévenir tout dommage à l'équipement ou toute blessure corporelle mineure sont également indiqués.

**NOTA : Les remarques donnent des renseignements importants requérant une attention particulière.**

### **⚠ AVERTISSEMENT**

**DANGER: BLESSURES PAR PERFORATION - Le jet de peinture à haute pression produit par cet appareil peut perforer la peau et les tissus sous-jacents et entraîner de sévères blessures pouvant nécessiter une amputation. Consultez immédiatement un médecin.**

**NE PAS TRAITER UNE BLESSURE PAR PERFORATION COMME UNE SIMPLE COUPURE! Une perforation peut entraîner des risques d'amputation. Consultez immédiatement un médecin.**

**Pression de service maximale du fluide dans l'appareil : 3200 lb/po2 / 221BAR.**

#### **MESURES PRÉVENTIVES:**

- NE JAMAIS diriger le pistolet vers une quelconque partie du corps.
- NE JAMAIS mettre une quelconque partie du corps en contact avec le jet de liquide. NE JAMAIS se mettre au contact d'un jet de liquide provenant d'une fuite du flexible d'alimentation en liquide.
- NE JAMAIS placer votre main devant le pistolet. Des gants ne vous protégeront pas contre les risques de blessures par perforation.
- TOUJOURS verrouiller la gâchette du pistolet, fermer la pompe à liquide et décompresser l'appareil lorsque vous travaillez sur celui-ci, nettoyez le protecteur de tête, remplacez la tête de pulvérisation ou vous éloignez de l'appareil. Couper le moteur ne décompresse pas l'appareil. Vous devez, pour le décompresser, placer le bouton AMORÇAGE/PULVÉRISATION en position AMORÇAGE. Reportez-vous, pour cela, à la PROCÉDURE DE DÉCOMPRESSION décrite dans de ce manuel.
- TOUJOURS s'assurer que le protecteur de tête est en place lorsque vous pulvérisiez. Le protecteur de tête offre une certaine protection contre les blessures par perforation mais sa principale fonction est d'ordre préventif.
- TOUJOURS ôter la tête de pulvérisation avant de purger ou nettoyer l'appareil.
- Le flexible d'alimentation en peinture peut fuir à la suite d'une usure, de chocs ou de mauvais traitements. Une fuite peut entraîner une perforation de la peau. Inspecter le flexible avant chaque utilisation.
- NE JAMAIS utiliser un pistolet dont la gâchette n'est pas munie d'un loquet ou un cran de sécurité qui soit en état de fonctionner.
- Tous les accessoires doivent être homologués pour une pression égale ou supérieure à 3200 lb/po2 / 221BAR. Cela s'applique, entre autres, aux têtes de pulvérisation, aux accessoires du pistolet et aux flexibles.

**AVERTISSEMENT AUX MÉDECINS : Une perforation sous-cutanée constitue un traumatisme. Il est important de traiter la blessure de façon chirurgicale aussitôt que possible. NE RETARDEZ PAS ce traitement pour des recherches de toxicité. La toxicité n'est un risque que dans les cas où certains produits de revêtement pénètrent dans le flux sanguin. Il peut être nécessaire de faire appel à des soins de chirurgie plastique ou de reconstruction de la main.**

**DANGER: RISQUES D'EXPLOSION OU D'INCENDIE - Les vapeurs dégagées par le solvant ou la peinture sont explosives et inflammables et peuvent causer des corporels sérieux ou dommages matériels.**

#### **MESURES PRÉVENTIVES:**

- Veiller à éviter toute accumulation de vapeurs inflammables en vous assurant que la zone où la pulvérisation a lieu est suffisamment ventilée.
- Veiller à éviter la présence de toute source incandescente telle qu'étincelle électrostatique, flamme nue, flamme-pilote, objet brûlant, cigarette et étincelle provenant du branchement ou du débranchement d'un cordon d'alimentation électrique ou d'un commutateur.
- Ne pas fumer dans la zone d'épandage.
- Toujours avoir un extincteur en état de fonctionner à portée de la main.
- Placer la pompe à peinture à une distance d'au moins un mètre (3 pi) (on recommande d'ailleurs une plus grande distance) de l'objet qui doit être vaporisé dans une pièce séparée bien aérée, ou à une distance d'au moins six mètres (20 pi) de celui-ci dans une zone bien aérée (utiliser d'autres tuyaux si nécessaires). Les vapeurs inflammables sont souvent plus lourdes que l'air. Le plancher doit être extrêmement bien aéré. La pompe à peinture contient des pièces pouvant créer des étincelles et enflammer les vapeurs présentes dans l'air.
- Le matériel utilisé, ainsi que les objets se trouvant à proximité de la zone de pulvérisation, doivent être convenablement reliés à la terre afin d'éviter toute étincelle ou toute décharge électrostatique.
- N'utiliser que des flexibles d'alimentation en liquide à haute pression conducteurs ou reliés à la terre dans les cas d'utilisation sans air comprimé. S'assurer que le pistolet est convenablement relié à la terre par l'intermédiaire du flexible.
- Le cordon d'alimentation doit être raccordé à un circuit mis à la terre.
- Toujours purger l'appareil dans un contenant métallique séparé, en s'assurant que la pompe soit à basse pression et que le chapeau soit retiré. Tenir le pistolet fermement contre la paroi du contenant pour mettre celui-ci à la terre et empêcher l'émission d'étincelles causées par l'électricité statique.
- Se conformer aux consignes et recommandations de sécurité du fabricant du solvant ou du produit.
- S'entourer de toutes les précautions possibles lorsqu'on utilise des produits ayant un point d'éclair inférieur à 21 °C (70 °F). Le point d'éclair d'un fluide est la température à laquelle les vapeurs émanant du fluide peuvent s'enflammer au contact d'une flamme ou d'une étincelle.
- Le plastique peut être une source d'étincelles provoquées par l'électricité statique. Ne jamais utiliser une couverture en plastique pour fermer une zone d'épandage ni utiliser des toiles de protection en plastique lors de la pulvérisation de matières inflammables.
- Lorsque vous purgez l'appareil, veillez à utiliser à la pression minimale.

## MOTEUR À ESSENCE (DANS LES CAS OÙ CELA S'APPLIQUE)

Toujours placer la pompe à l'extérieur de la structure à l'air frais. Garder tous les solvants loin de l'échappement du moteur. Ne jamais remplir le réservoir à carburant lorsque le moteur est en marche ou lorsqu'il est chaud ; les surfaces chaudes risquent d'enflammer le carburant déversé accidentellement. Toujours raccorder un fil de mise à la terre entre la pompe et un objet mis à la terre, tel qu'une conduite d'eau métallique. Se reporter au guide d'utilisation du moteur pour obtenir de plus amples renseignements concernant la sécurité.

**DANGER: RISQUES D'EXPLOSION PAR INCOMPATIBILITÉ DES MATÉRIAUX - Peuvent être à l'origine de corporels sérieux ou dommages matériels.**

### MESURES PRÉVENTIVES:

- Ne pas utiliser de matériaux contenant des agents de blanchiment ou du chlore.
- Ne pas utiliser des solvants à base d'hydrocarbure halogéné tels que l'agent anticryptogamique, le chlorure de méthylène et le trichloro-éthane-1,1,1. Ces produits ne sont pas compatibles avec l'aluminium.
- Communiquer avec votre fournisseur de revêtement pour connaître la compatibilité du matériau avec l'aluminium.

**DANGER: VAPEURS NOCIVES – la peinture, les solvants, les insecticides et autres matériaux peuvent être nocifs lorsqu'ils sont inhalés ou en contact avec le corps. Les vapeurs peuvent causer une nausée importante, des évanouissements ou un empoisonnement.**

### MESURES PRÉVENTIVES:

- Utiliser un respirateur ou un masque chaque fois qu'il y a des risques d'inhalation de vapeurs. Lire attentivement toutes les instructions se rapportant au masque pour vérifier que celui-ci vous assure une protection suffisante contre les vapeurs toxiques.
- Porter des lunettes de protection.
- Porter des vêtements de protection, conformément aux directives du fabricant de revêtement.

**DANGER: GÉNÉRALITÉS - Peut causer des dommages matériels ou corporels sérieux.**

### MESURES PRÉVENTIVES:

- Avant d'utiliser tout équipement, lire attentivement toutes les instructions et les consignes de sécurité.
- Toujours débrancher le moteur de l'alimentation électrique avant d'effectuer des travaux sur l'appareil.
- Se conformer à la législation locale, provinciale ou fédérale pour tout ce qui concerne la ventilation, la prévention des incendies et les conditions générales d'utilisation.
- Les normes de sécurité du Gouvernement américain sont régies par le Occupational Safety and Health Act (OSHA). Il est important de consulter ces normes, en particulier la section 1910 sur les normes générales et la section 1926 sur les normes de la construction.
- N'utiliser que les pièces autorisées par le fabricant. L'utilisateur assume tous les risques et responsabilités lorsqu'il utilise des pièces qui ne sont pas conformes aux caractéristiques techniques minimales ainsi qu'aux dispositifs de sécurité du fabricant de la pompe.
- Vérifier, avant toute utilisation, que les flexibles ne présentent pas d'entaille ou de fuite, que le couvercle ne soit pas gonflé et que les raccords ne soient pas endommagés. Si le flexible a subi l'un des dommages précités, remplacez-le immédiatement. Ne jamais réparer un flexible d'alimentation en peinture. Le remplacer par un autre flexible mis à la terre.
- Tout flexible, raccord orientable, pistolet et accessoire utilisé avec cet appareil doit pouvoir fonctionner à une pression égale ou supérieure à 3200 lb/po<sup>2</sup> / 221BAR.
- Ne jamais pulvériser lorsqu'il vente.
- Porter des vêtements pour protéger la peau et les cheveux contre tout contact avec la peinture.

## Instructions de mise à la terre

Cet appareil doit être mis à la terre. La mise à la terre réduit les risques d'électrocution lors d'un court-circuit en permettant au courant de s'écouler par le fil de mise à la terre. Cet appareil est muni d'un cordon électrique avec fil de mise à la terre ainsi que d'une fiche de terre. La fiche doit être branchée sur une prise installée correctement et mise à la terre conformément à la réglementation et aux codes en vigueur.

**DANGER — Une prise de terre mal branchée peut être à l'origine d'électrocutions. S'il s'avère nécessaire de réparer ou de remplacer le cordon électrique ou la fiche, ne pas brancher le fil vert de mise à la terre sur l'une ou l'autre des bornes à broche plate. Le fil recouvert d'un isolant vert avec ou sans rayures jaunes est le fil de mise à la terre et doit être branché sur la broche de mise à la terre.**

Si vous ne comprenez pas les instructions de mise à la terre ou si vous n'êtes pas sûr que l'appareil est correctement mis à la terre, contactez un électricien agréé. Ne pas modifier la fiche d'origine. Si la prise ne convient pas à la fiche, faites installer la prise adéquate par un électricien agréé.

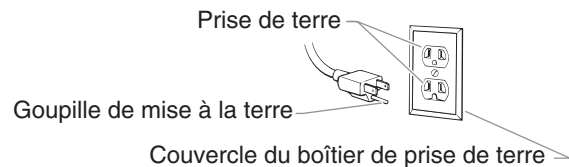

**ATTENTION**

Utiliser uniquement une rallonge à trois fils munie d'une fiche de terre dans une prise secteur mise à la terre correspondant au type de fiche de l'appareil. S'assurer que votre rallonge est en bon état. Lorsque vous utilisez une rallonge, assurez-vous qu'elle soit d'un calibre suffisant pour supporter l'intensité du courant requise par l'appareil. Une rallonge trop mince entraîne une chute de tension, une diminution de l'intensité et une surchauffe. Une rallonge de calibre 12 est recommandée. Si vous devez utiliser une rallonge à l'extérieur, celle-ci doit comprendre la marque W-A après la désignation indiquant le type de cordon. Par exemple, la désignation SJTW-A indique que le cordon est conçu pour être utilisé à l'extérieur.



## Precauciones de seguridad

Este manual contiene información que debe leer y comprender antes de usar el equipo. Cuando se encuentre con uno de los siguientes símbolos, asegúrese de observar sus indicaciones de seguridad.

### **⚠ ADVERTENCIA**

Este símbolo indica la existencia de un peligro potencial que puede causar lesiones graves o la muerte. Después del mismo se incluye información de seguridad importante.

### **⚠ PRECAUCION**

Este símbolo indica la existencia de un peligro potencial para usted o el equipo. Después del mismo se incluye información importante que indica la forma de evitar daños al equipo o la forma de prevenir lesiones menores.

**NOTA: los avisos contienen información importante, présteles especial atención.**

### **⚠ ADVERTENCIA**

**PELIGRO: LESIÓN POR INYECCIÓN** - La corriente de pintura de alta presión que produce este equipo puede perforar la piel y tejidos subyacentes, lo que conduciría a lesiones serias y una posible amputación. Consulte de inmediato a un médico.

**NO TRATE LAS LESIONES POR INYECCIÓN COMO SI FUERAN SIMPLES CORTADAS!** Una inyección puede conducir a una amputación. Consulte de inmediato a un médico.

**El rango de operación máximo de la unidad es 3200 PSI / 221BAR de presión de fluidos.**

#### **PARA PREVENIR:**

- NO dirija NUNCA la punta de la pistola hacia alguna parte del cuerpo.
- NO permita NUNCA que alguna parte del cuerpo tenga contacto con la corriente del fluido. EVITE tener contacto con corrientes de fluido que salgan de fugas que haya en la manguera.
- NO ponga NUNCA la mano enfrente de la manguera. Los guantes no ofrecen ninguna protección contra lesiones por inyección.
- Bloquee SIEMPRE el gatillo de la pistola, apague la bomba de fluido y libere toda la presión antes de dar mantenimiento, limpiar el protector de la boquilla, cambiar la boquilla o dejar desatendido el equipo. La presión no se liberará al apagar el motor. Para liberar la presión debe girarse la perilla PRIME/SPRAY (cebar/atomizar) hasta la posición PRIME. Consulte el PROCEDIMIENTO PARA LIBERAR LA PRESIÓN que se describe en este manual.
- Mantenga puesto SIEMPRE el protector de la boquilla mientras atomice. El protector de la boquilla ofrece cierta protección contra lesiones por inyección pero es principalmente un dispositivo de advertencia.
- Quite SIEMPRE la boquilla del atomizador antes de enjuagar o limpiar el sistema.
- Pueden desarrollarse fugas en la manguera de pintura por causa del desgaste, retorcimientos o el abuso. Una fuga es capaz de inyectar el material en la piel. Cada vez que use la manguera de pintura, inspecciónela antes.
- NO use nunca una pistola de atomización que no tenga un bloqueador o un protector de gatillo puesto y que funcione.
- Todos los accesorios deben tener una capacidad de 3200 lb/pulg<sup>2</sup> / 221BAR o mayor. Esto incluye las boquillas de atomizador, pistolas, extensiones y mangueras.

**NOTA PARA EL MÉDICO:** La inyección dentro de la piel es una lesión traumática. Es importante que la lesión se trate quirúrgicamente tan pronto como sea posible. NO retrase el tratamiento por investigar la toxicidad. La toxicidad es motivo de preocupación con algunos revestimientos que se inyectan directamente en la corriente sanguínea. Es recomendable consultar a un cirujano plástico o reconstructor de manos.

**PELIGRO: EXPLOSIÓN O INCENDIO** - Los vapores de solventes y pintura pueden explotar o incendiarse, causando con esto lesiones severas y/o daños en la propiedad.

#### **PARA PREVENIR:**

- Debe proveerse un escape y aire fresco para hacer que el aire que está dentro del área de atomización se mantenga libre de acumulaciones de vapores inflamables.
- Evite todas las fuentes de ignición como son las chispas electrostáticas, llamas abiertas, flamas de piloto, objetos calientes, cigarros, y chispas que se generan al conectar y desconectar las extensiones o de apagadores de luz que estén funcionando.
- No fume en la zona de trabajo.
- Debe haber un equipo para extinguir incendios permanentemente y en buenas condiciones.
- Coloque la bomba para pintar a un mínimo de 1 m (de preferencia más) en una habitación aparte, bien ventilada, alejada del objeto que va a pintar o a por lo menos 6 m de dicho objeto, en una zona bien ventilada (utilice una manguera más larga, si es necesario). Los gases inflamables a menudo son más pesados que el aire. La zona del piso debe tener la debida ventilación. La bomba para pintar contiene piezas que forman arcos que emiten chispas y pueden encender los gases.
- El equipo que se utilice, así como los objetos que estén dentro y alrededor del área de atomización, deben conectarse a tierra de manera apropiada para prevenir las descargas eléctricas y las chispas.
- Use solamente mangueras para fluidos de alta presión, conductoras o conectadas a tierra, para aplicaciones sin aire. Asegúrese de que la pistola esté conectada a tierra de manera apropiada, mediante conexiones de manguera.
- El cable de alimentación debe enchufarse a un circuito aterrado.
- Siempre enjuague la unidad en un recipiente de metal por separado, con presión baja en la bomba y sin la boquilla. Sostenga la pistola firmemente contra el recipiente para ponerlo a tierra y evitar chispas estáticas.
- Siga las advertencias y avisos de seguridad del fabricante de los materiales y solventes.
- Tenga muchísimo cuidado al usar materiales cuyo punto de ignición sea inferior a 70° F (21° C). El punto de ignición es la temperatura a la cual pueden encenderse los vapores emanados por un fluido al exponerlos a llamas o chispas.
- El plástico puede causar chispas estáticas. Nunca cuelgue plástico en las ventanas ni en las puertas del área donde va a pintar. No utilice plástico para proteger el piso cuando pinte materiales inflamables.
- Cuando enjuague el equipo utilice la presión más baja posible.

#### **MOTOR DE GAS (SEGÚN CORRESPONDA)**

Coloque siempre la bomba fuera del edificio, al aire libre. Mantenga todo solvente alejado del escape del motor. Nunca llene el tanque de combustible si el motor está encendido o caliente. La superficie caliente puede encender el combustible derramado. Conecte siempre un conductor de tierra desde la unidad de la bomba a un objeto puesto a tierra, por ejemplo una tubería de agua metálica. Consulte el manual del motor para obtener información completa de seguridad.

**PELIGRO: PELIGRO DE EXPLOSIÓN DEBIDO A MATERIALES INCOMPATIBLES - Podría causar lesiones severas o daños en la propiedad.**

**PARA PREVENIR:**

- No utilice materiales que contengan blanqueador o cloro.
- No use solventes con hidrocarburos halogenados, tales como productos para eliminar el moho, cloruro de metileno y 1,1,1 - tricloroetano. Estos no son compatibles con el aluminio.
- Comuníquese con el proveedor del producto para obtener información de compatibilidad con materiales de aluminio.

**PELIGRO: GASES PELIGROSOS - Las pinturas, solventes, insecticidas y otros materiales pueden ser perjudiciales si se inhalan o entran en contacto con el cuerpo. Los gases pueden causar náusea, desmayos o envenenamiento graves.**

**PARA PREVENIR:**

- Use una mascarilla respiratoria o careta siempre que exista la posibilidad de que se puedan inhalar vapores. Lea todas las instrucciones que vengan con la careta para estar seguro de que se tendrá la protección necesaria contra la inhalación de vapores dañinos.
- Use gafas protectoras.
- Use ropa de protección, según lo requiera el fabricante del producto.

**PELIGRO: GENERAL - Puede causar daños en la propiedad o lesiones severas.**

**PARA PREVENIR:**

- Lea todas las instrucciones y advertencias de seguridad antes de hacer funcionar cualquier equipo.
- Desconecte siempre el motor del suministro eléctrico antes de dar servicio al equipo.
- Observe todos los códigos locales, estatales y nacionales apropiados que rigen las medidas de ventilación, prevención de incendios y operación.
- Los Estándares de Seguridad del Gobierno de los Estados Unidos se han adoptado bajo el Acta de Seguridad y Salud Ocupacionales (OSHA por sus siglas en inglés). Deben consultarse estos estándares, particularmente la parte 1910 de los Estándares Generales y la parte 1926 de los Estándares de la Construcción.
- Utilice únicamente piezas autorizadas por el fabricante. El usuario asume todos los riesgos y responsabilidades si usa piezas que no cumplen con las especificaciones mínimas y dispositivos de seguridad del fabricante de la bomba.
- Antes de usarla cada vez, revise todas las mangueras para ver que no tengan cortadas, fugas, una cubierta desgastada por abrasión o con abolladuras, así como uniones dañadas o que se hayan movido. Si existiera cualquiera de estas condiciones, reemplace la manguera inmediatamente. No repare nunca una manguera de pintura. Reemplácela con otra manguera conectada a tierra.
- Todas las mangueras, soportes giratorios, pistolas y accesorios que se usen con esta unidad deben tener una capacidad de presión de 3200 lb/pulg<sup>2</sup> / 221 BAR o mayor.
- No atomice en días con viento.
- Use ropa que evite el contacto de la pintura con la piel y el cabello.

## Instrucciones para conectar a tierra

Este producto se debe conectar a tierra. En caso de que ocurra un corto circuito, la conexión a tierra reduce el riesgo de choque eléctrico al proporcionar un alambre de escape para la corriente eléctrica. Este producto está equipado con un cable que tiene un alambre de conexión a tierra con un enchufe de conexión a tierra apropiado. El enchufe se debe enchufar en una toma de corriente que se haya instalado y conectado a tierra debidamente, de acuerdo con todos los códigos y estatutos locales.

**PELIGRO** — Una instalación inapropiada del enchufe de conexión a tierra puede dar como resultado el que exista un riesgo de choque eléctrico. Si es necesario reparar o reemplazar el cable o el enchufe, no conecte el alambre de conexión a tierra a ninguno de los terminales de hoja planas. El alambre con aislamiento que tiene la superficie exterior de color verde con franjas amarillas o sin ellas es el alambre de conexión a tierra que debe conectarse al conector de conexión a tierra.

Verifique con un electricista o técnico de servicio calificado si las instrucciones para conectar a tierra no le han quedado completamente claras, o si duda que el producto haya quedado conectado a tierra de manera apropiada. No modifique el enchufe que se proporciona. Si el enchufe no entra en la toma de corriente, pídale a un electricista calificado que instale la toma apropiada.

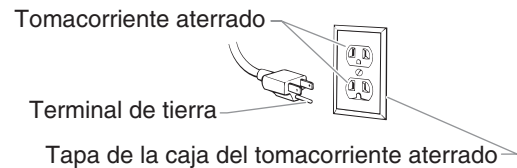

**PRECAUCION**

Use solamente extensiones trifilares que tengan un enchufe de conexión a tierra de 3 hojas y un receptáculo de triple ranura que acepte el enchufe del producto. Asegúrese de que su extensión esté en buenas condiciones. Cuando use una extensión, asegúrese de usar una que sea lo suficientemente resistente como para soportar la corriente que descargue su producto. Un cable de un tamaño menor causará una caída de voltaje en la línea que dará como resultado una pérdida de energía y un sobrecalentamiento. Se recomienda usar un cable de calibre 12. Si se utiliza un cable de extensión en el exterior, tiene que estar marcado con el sufijo W-A después de la designación del tipo de cable. Por ejemplo, SJTW-A para indicar que el cable es apropiado para uso en exteriores.

# Parts List

## Main Assembly

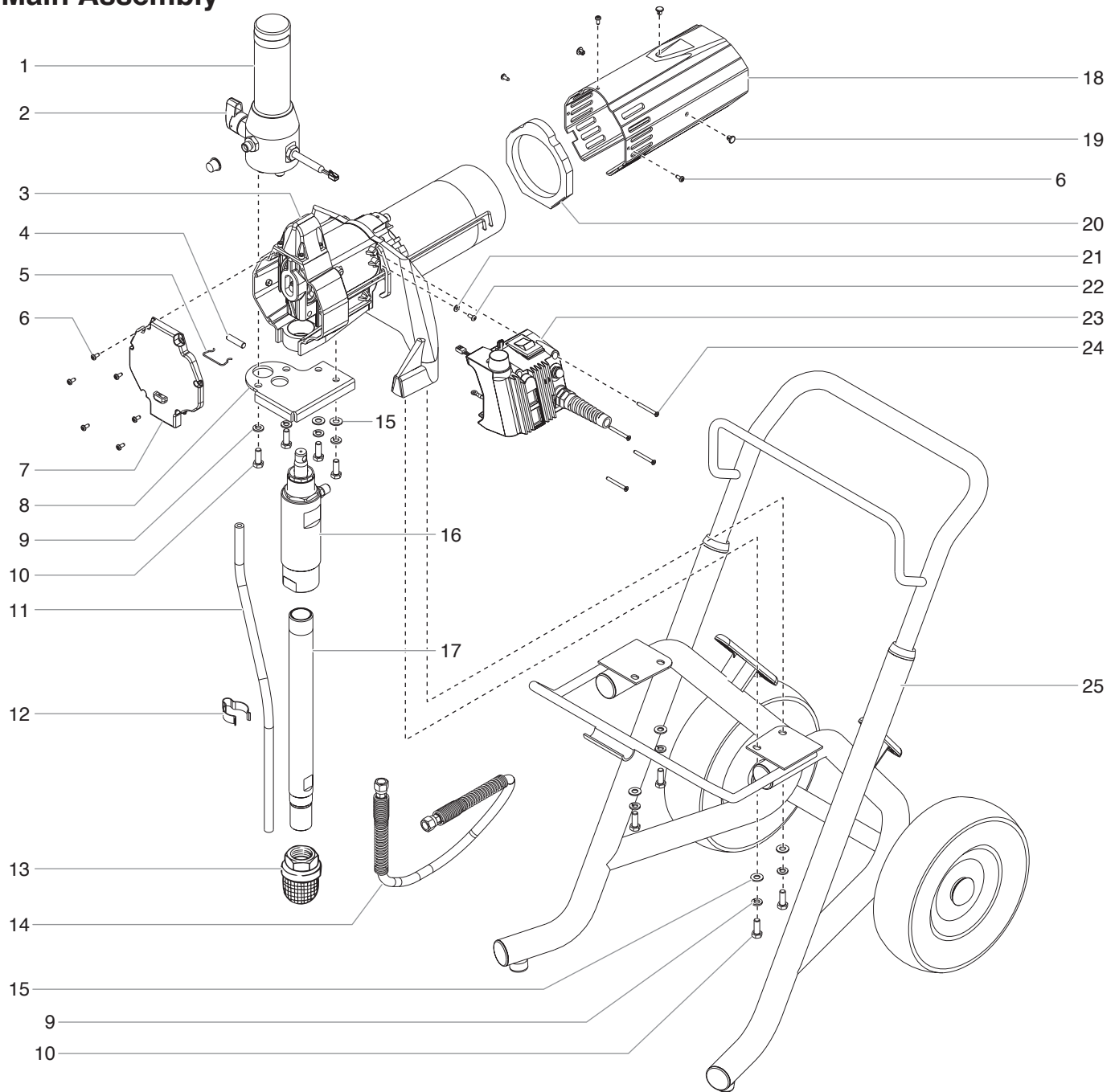

Item	Part #	Description	Quantity	Item	Part #	Description	Quantity
1	-----	Filter assembly.....	1	14	13549	Hose .....	1
2	0507690	PRIME/SPRAY valve assembly.....	1	15	0088372	Flat washer .....	6
3	-----	Drive assembly .....	1	16	0507210	Fluid section assembly .....	1
4	0295520	Connecting pin.....	1	17	0507703	Siphon tube.....	1
5	0295519	Retaining clip .....	1	18	0507954	Motor shroud w/labels (includes item 19)...	1
6	9802286	Screw .....	9	19	0507794	Plug.....	3
7	0507948	Front cover.....	1	20	0507863	Baffle.....	1
8	0507710	Filter mounting plate .....	1	21	9822113	Ground washer .....	1
9	51357	Lock washer.....	8	22	9800340	Ground screw .....	1
10	0507957	Screw .....	8	23	0507189	Pressure control assembly .....	1
11	0507785	Return hose .....	1	24	9802896	Screw.....	4
12	0507783	Hose clamp.....	1	25	-----	Upright cart assembly .....	1
13	5006536	Inlet screen .....	1				

# Drive Assembly

**NOTE: All electrical work should be performed by a SprayTECH authorized service center.**

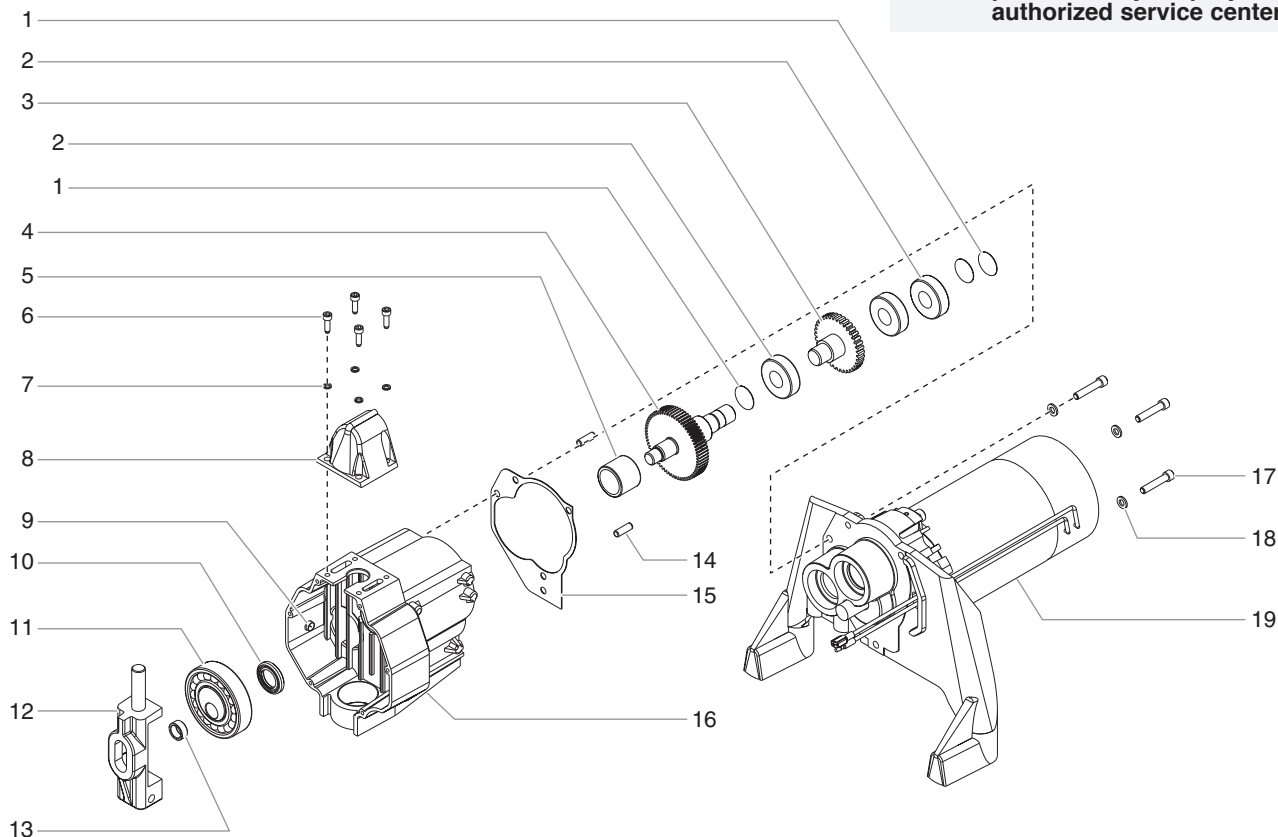

Item	Part #	Description	Quantity
1	0295335	Thrust washer .....	3
2	9860417	Ball bearing .....	3
3	0507938	1st stage gear set .....	1
4	0507933	Output gear assembly .....	1
5	9860424	Bearing .....	1
6	9800339	Screw .....	4
7	9821515	Lock washer .....	4
8	0507932	Yoke guide assembly .....	1
9	9850640	Plug .....	1
10	0295327	Seal .....	1
11	0507934	Eccentric assembly .....	1
12	0295518	Yoke .....	1

Item	Part #	Description	Quantity
13	0295322	Output bushing .....	1
14	9830116	Dowel pin .....	2
15	0295325	Housing gasket .....	1
16	0507716	Gear box housing .....	1
17	54190	Screw .....	3
18	9820213	Flat washer .....	3
19	0507178	Motor assembly .....	1
	0507935	Front gear box assembly (includes items 1, 2, 4, 5, 9, 10, 11, 14, and 16)	
	0507927	Motor brush kit	

# Suction Set Assembly (Low Boy)

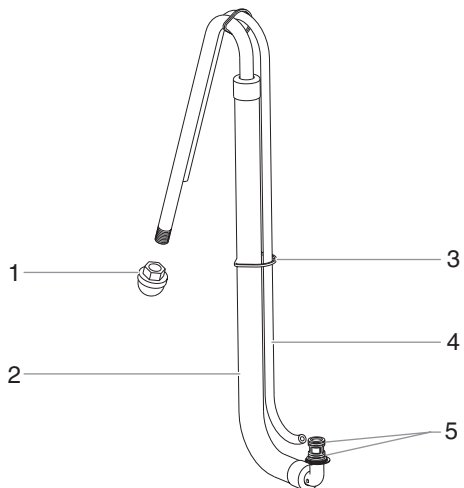

Item	Part #	Description	Quantity
1	0295565	Inlet screen .....	1
2	0507228	Siphon hose assembly .....	1
3	9850638	Tie wrap .....	2
4	0507936	Return hose .....	1
5	9871105	O-ring .....	2
6	0507937	Hose clip (not shown) .....	1

# Labels

Part #	Description
0507821	Logo label, front
0507860	Logo label, left
0507861	Logo label, right
0295803	Warning label, explosion
0295804	Warning label, injection
0295805	Shock hazard label
0507855	"Press to Reset" label
0508330	PRIME/SPRAY knob label
0507856	PRIME/SPRAY label
0507857	Pressure increase label

# Fluid Section Assembly (Upright Cart P/N 0507210) (Low Boy Cart P/N 0507215)

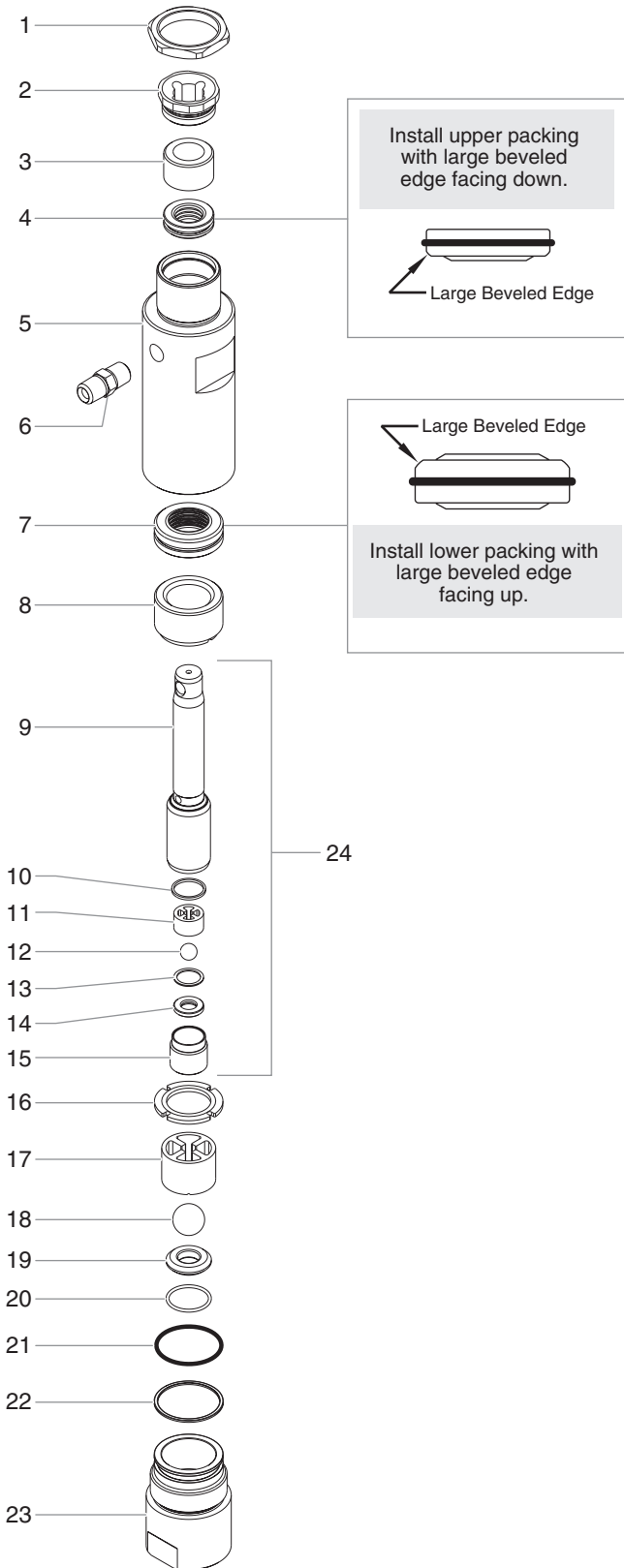

Item	Part #	Description	Quantity
1	00302	Jam nut.....	1
2	0507946	Upper seal retainer.....	1
3	0507665	Upper support ring.....	1
4	0507941	Upper packing assembly.....	1
5	0507947	Cylinder.....	1
6	02518	Nipple, 1/4".....	1
7	0507942	Lower packing assembly.....	1
8	0507666	Lower support ring.....	1
9	0507928	Piston rod.....	1
10	0507734	Outlet valve seal.....	1
11	0507945	Outlet valve cage.....	1
12	9841502	Outlet valve ball.....	1
13	0507454	Washer, nylon.....	1
14	0294516	Outlet valve seat.....	1
15	0507733	Outlet valve retainer.....	1
16	0507943	Support washer.....	1
17	0507944	Inlet valve cage.....	1
18	51519	Inlet valve ball.....	1
19	00310	Inlet valve seat.....	1
20	00203	O-ring, Teflon.....	1
21	0507730	O-ring, Viton.....	1
22	0507731	Back-up ring, Teflon.....	1
23	0507728	Inlet valve housing (Upright cart).....	1
	0507570	Inlet valve housing (Low Boy).....	1
24	0507211	Piston assembly (includes items 9–15).....	1
	0507929	Repacking kit (includes items 3, 4, 7, 8, 11, 12, 14, 18, and 20–22)	
	0507926	Lower seal insertion tool	

**NOTE:** When repacking the fluid section, make sure the raised lip on the bottom of the lower packing is fully outside the packing around the piston rod after insertion of the piston rod.

## Upright Cart Assembly

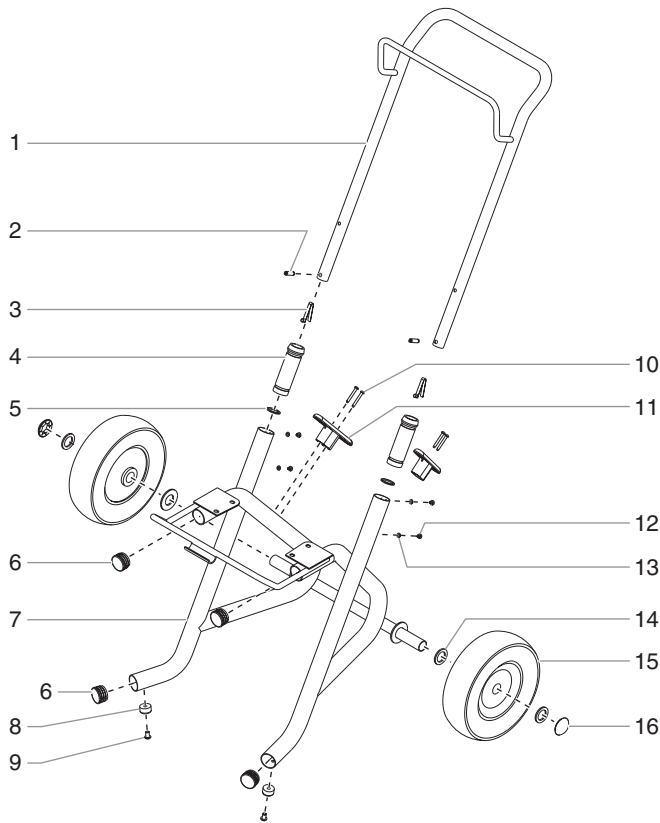

Item	Part #	Description	Quantity
1	0507939	Handle (includes items 2-5, 12, and 13)	1
2	0295610	Roll pin	2
3	9841504	Snap button	2
4	0295607	Sleeve	2
5	0295609	Washer	2
6	9885571	Plug	2
7	0507940	Cart weldment (includes items 6, 8, and 9)	1
8	13538	Bumper	2
9	54458	Screw	2
10	0507774	Screw	4
11	0507655	Cord wrap	2
12	0295608	Screw	4
13	0295606	Washer	4
14	0294534	Spacer	4
15	0278373	Wheel	2
16	9890104	Cap	2

## Filter Assembly

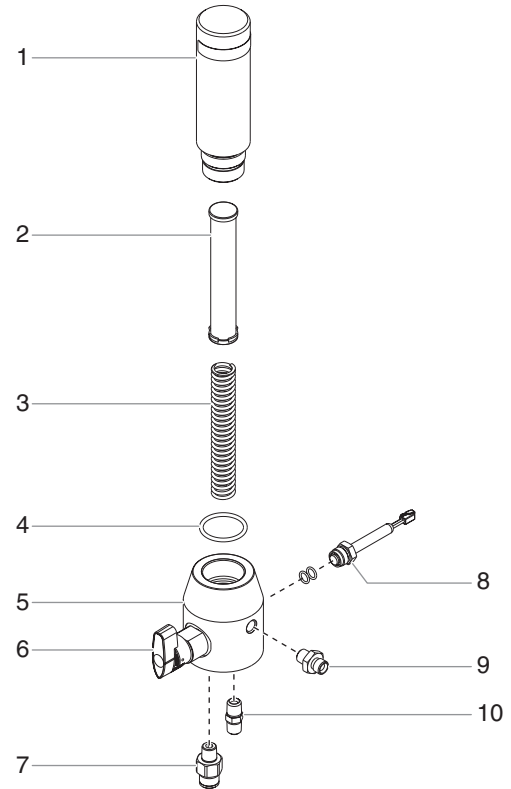

Item	Part #	Description	Quantity
1	0294194	Filter body assembly	1
2	14069	Filter, 50 mesh	1
3	9894245	Core spring	1
4	14072	O-ring, Teflon	1
5	0507712	Filter housing	1
6	0507690	PRIME/SPRAY valve assembly	1
7	0507793	Fitting, 1/4"	1
8	0507970	Transducer	1
9	05045	Outlet fitting	1
10	02518	Nipple, 1/4"	1

## Pressure Control Assembly

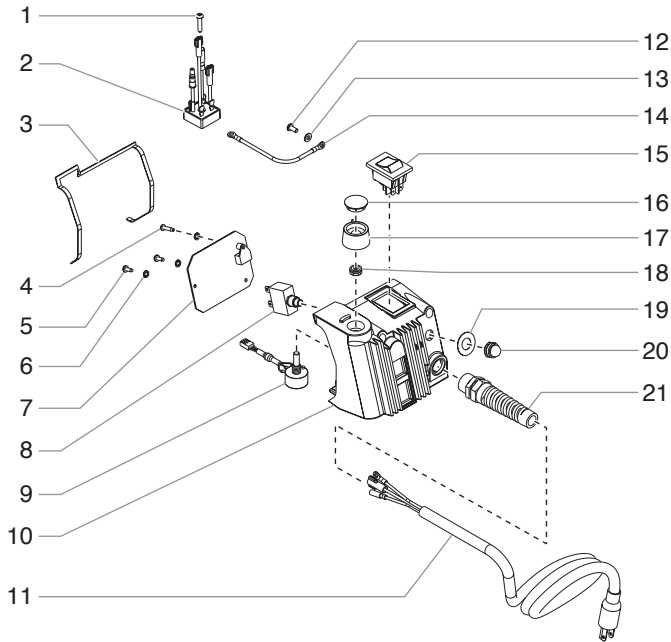

Item	Part #	Description	Quantity
1	9802244	Screw.....	1
2	0507971	Rectifier.....	1
3	0507717	Control panel gasket.....	1
4	0507714	Screw.....	1
5	0507792	Screw.....	2
6	0507972	Lock washer.....	3
7	0507212	Circuit board assembly.....	1
8	0507930	Circuit breaker.....	1
9	0507973	Potentiometer.....	1
10	0507629	Control housing.....	1
11	0507727	Cord assembly.....	1
12	9800340	Ground screw.....	1
13	9822113	Ground washer.....	1
14	0507790	Ground wire assembly.....	1
15	9850936	ON/OFF switch.....	1
16	0507748	Knob cap.....	1
17	0507740	Pressure control knob.....	1
18	0507749	Nut w/seal.....	1
19	0507855	Label, "Press to Reset".....	1
20	9850938	Circuit breaker boot.....	1
21	9850664	Strain relief.....	1

## Low Boy Cart Assembly

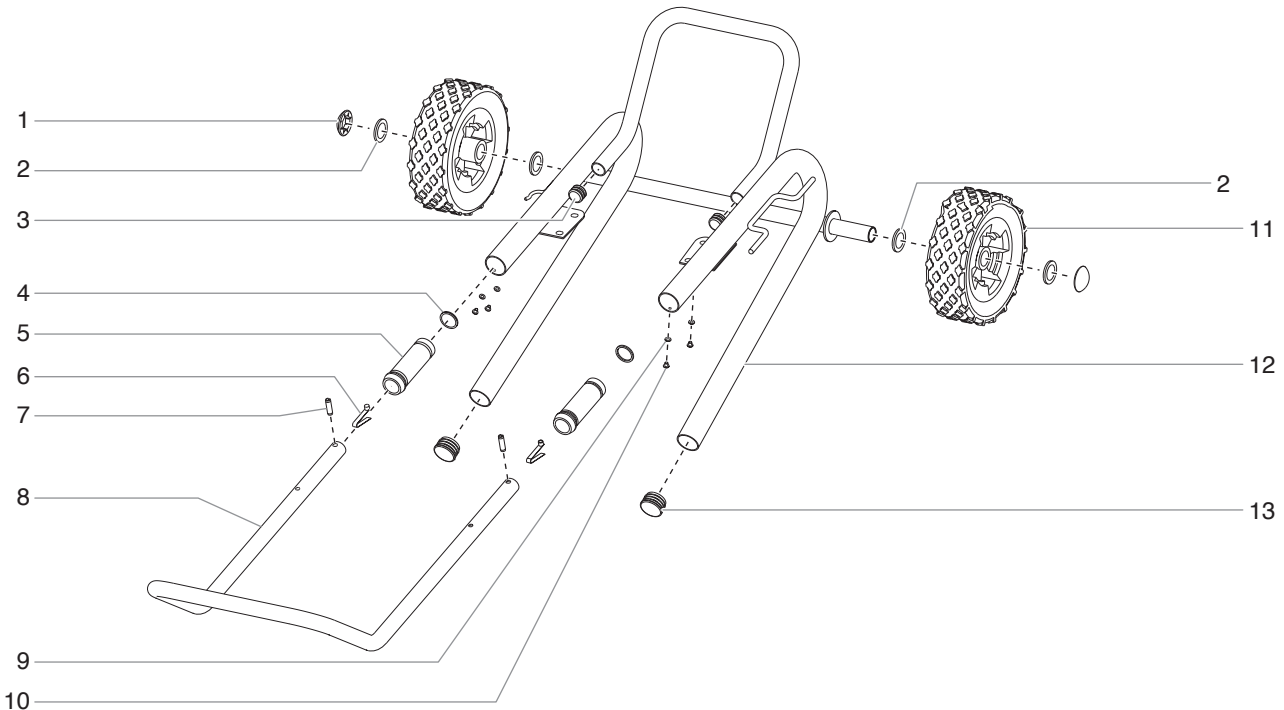

Item	Part #	Description	Quantity	Item	Part #	Description	Quantity
1	9890104	Cap.....	2	8	0507950	Handle assembly (includes items 4-10).....	1
2	0294534	Wheel spacer.....	4	9	0295606	Washer.....	4
3	9885546	Plug.....	2	10	0295608	Screw.....	4
4	0295609	Washer.....	2	11	0270394	Wheel.....	2
5	0295607	Sleeve.....	2	12	0507949	Cart weldment (includes items 3 and 13).....	1
6	9841504	Snap button.....	2	13	9885571	Plug.....	2
7	0295610	Roll pin.....	2				

# PRIME/SPRAY Valve Assembly (P/N 0507690)

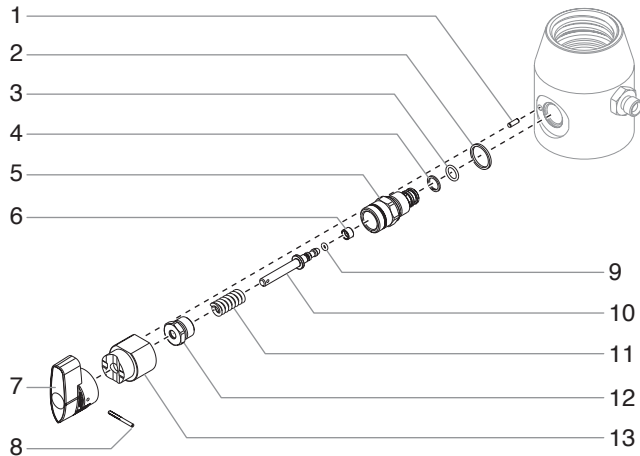

Item	Part #	Description	Quantity
1	0507736	Dowel pin	1
2	0507745	Gasket	1
3	5000529	O-ring, Teflon	1
4	0507741	O-ring, Viton	1
5	0507744	Valve housing	1
6	0507746	Valve seat	1
7	0507662	Valve handle	1
8	5006543	Groove pin	1
9	5006547	O-ring, Viton	1
10	0507743	Valve stem	1
11	0507747	Spring	1
12	0507742	Valve retainer	1
13	0507735	Cam base	1

# Accessories

Part No.	Description
0297xxx	RC Tip Assembly
0502xxx	Replacement Core, RC Tip
0297078	Tip Guard, RC Tip (11/16")
0297070	Tip Guard, RC Tip (7/8")
0291004	Hose, Whip End, 3' x 3/16"
0291003	Hose, Whip End, 5' x 3/16"
0291002	Hose, Wireless, 25' x 1/4"
0291000	Hose, Wireless, 50' x 1/4"
0093896	Hose Connector, 1/4" x 1/4"M
0088154	Pressure Gauge
0152001	Power Roller Gun Attachment
0152308	9" Roller Cover, 3/8" Nap
0152307	9" Roller Cover, 1/2" Nap
0152309	9" Roller Cover, 3/4" Nap
0152310	9" Roller Cover, 1-1/4" Nap
0152235	12" Roller Cover, 1/2" Nap
0152236	12" Roller Cover, 3/8" Nap
0152237	12" Roller Cover, 3/4" Nap
0152238	12" Roller Cover, 1-1/4" Nap
0152700	Adapter, Power Roller Extension
0270145	G-10 Four Finger Airless Spray Gun (no tip)
0093930	Anti-Seize Compound
0152909	R-10 Telescoping Roller, 9", 3/8" Nap
0152900	R-10 Telescoping 12" Roller, 3/8" Nap
0502007	G-10 Four Finger Airless Spray Gun with 517 Reversible Tip
0502011	G-10 Two Finger Airless Spray Gun (no tip)
0502009	G-10 Two Finger Airless Spray Gun with 517 Reversible Tip
0270214	G-10 Four Finger Spray Pack with 50' x 1/4" airless hose
0502012	G-10 Two Finger Spray Pack with 50" x 1/4" Airless Hose
0279920	Separating oil
0507958	Electrostatic discharge (ESD) wrist strap
9870307	Grease, 6 lb. can

# Electrical Schematic

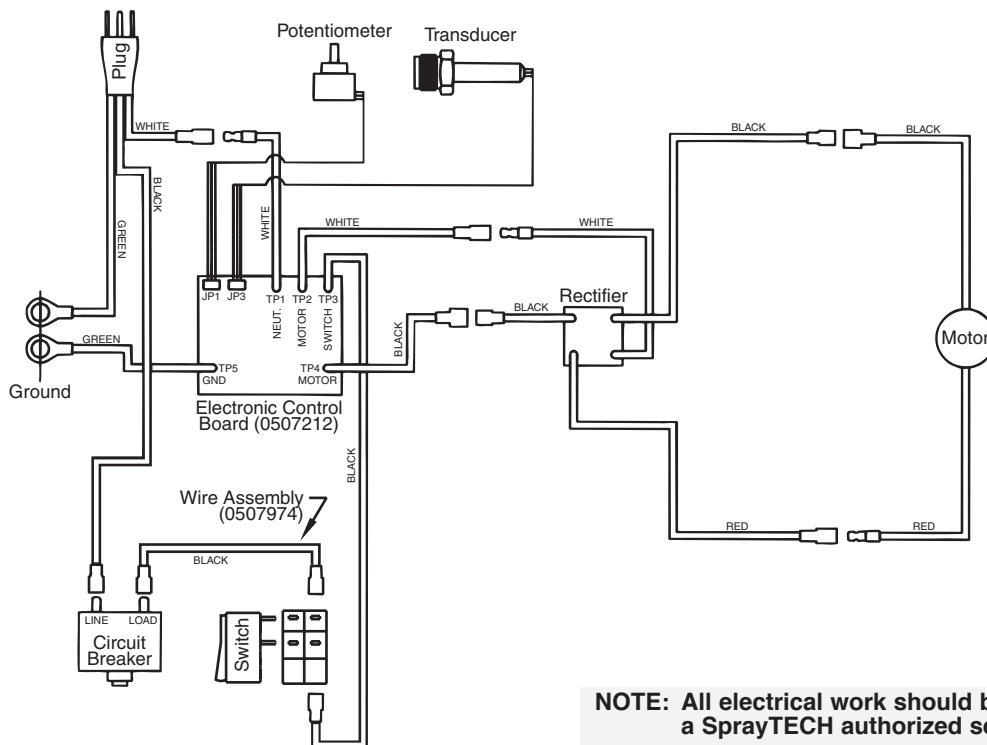

**NOTE: All electrical work should be performed by a SprayTECH authorized service center.**



# Limited Warranty

## Commercial Airless Spray Equipment

### Two Year Warranty

SprayTECH, a division of Wagner Spray Tech Corporation ("SprayTECH"), warrants this product against defects in material and workmanship for a period of two years following the date of purchase by the original purchaser. During that period, SprayTECH will repair or replace any defective or worn-out component or, at SprayTECH's option, refund to the original purchaser the full purchase price for the product in exchange for the return of that product. However, SprayTECH will not replace or repair any fluid pump component on account of wear more than once during the two year warranty period. This warranty does not cover consumable products such as filters and tips.

### Lifetime Warranty on Gear Trains, Electric Motors, and Gas Engines

SprayTECH warrants any gear train, electric motor (excluding brushes) and gas engine (excluding the clutch) in this product **against defects in material and workmanship for the lifetime of the original purchaser**. If SprayTECH determines that the foregoing warranty has been breached, SprayTECH will repair or replace the defective components without charge or, at SprayTECH's option, refund to the original purchaser the full purchase price for the product in exchange for the return of that product.

### Warranty Claims

Any request for repair or replacement pursuant to the warranties above must be accompanied by the return of the applicable parts, with transportation charges prepaid, to a service center authorized by SprayTECH or to Wagner Spray Tech Corporation, 1770 Fernbrook Lane, Minneapolis, MN 55447.

### Limitation of Remedies

THE REMEDIES SET FORTH ABOVE ARE THE EXCLUSIVE REMEDIES AVAILABLE FOR BREACH OF EXPRESS AND IMPLIED WARRANTIES. These remedies shall not be deemed to have failed of their essential purpose so long as SprayTECH is willing to repair or replace parts, or to refund the purchase price, as set forth above.

### What Is Not Covered By This Warranty

This warranty does not cover defects or damages caused by:

- the use or installation of repair or replacement parts or accessories not manufactured by SprayTECH;
- repair performed by anyone other than a SprayTECH Authorized Service Center; or
- abuse, misuse, negligence, accident, faulty installation or tampering in a manner which impairs normal operation.

This warranty also does not cover equipment and accessories supplied to SprayTECH from an original equipment manufacturer, including but not limited to hoses, tips, and accessories. SprayTECH will provide the purchaser with copies of the original equipment manufacturer's express warranties provided to SprayTECH along with the name and address of the appropriate manufacturer.

### Limitation of Remedies

IN NO CASE SHALL SPRAYTECH BE LIABLE FOR ANY INCIDENTAL, SPECIAL OR CONSEQUENTIAL DAMAGES OR LOSS, INCLUDING TRANSPORTATION COSTS, WHETHER SUCH DAMAGES ARE BASED UPON A BREACH OF EXPRESS OR IMPLIED WARRANTIES, BREACH OF CONTRACT, NEGLIGENCE, STRICT TORT, OR ANY OTHER LEGAL THEORY.

### Disclaimer of Implied Warranties

THE FOREGOING WARRANTIES ARE IN LIEU OF ALL OTHER WARRANTIES, EXPRESS OR IMPLIED, INCLUDING BUT NOT LIMITED TO THE IMPLIED WARRANTIES OF MERCHANTABILITY AND FITNESS FOR A PARTICULAR PURPOSE.

### No Ability To Transfer

This warranty is extended to the original purchaser only and is not transferable.

#### SprayTECH 30-Day Satisfaction Guarantee

If, within a 30-day period from the date of purchase, you are not totally satisfied with a SprayTECH/CAPSpray unit, you may return it for full credit toward another SprayTECH or CAPSpray product of equal or greater value.

Material Safety Data Sheets (MSDS) are available on SprayTECH's website or by calling Technical Service.

### **SprayTECH®**

1770 Fernbrook Lane  
Minneapolis, Minnesota 55447  
Telephone 1-800-292-4637