



Advanced Performance. Total Reliability.

Owner's Manual
Notice d'utilisation
Manual del Propietario
Do not use this equipment before
reading this manual!

ADVANTAGE GPX 220

Gas Piston Pump



Model Number: 0509023

NOTE: This manual contains important warnings and instructions. Please read and retain for reference.

Important Safety Information



Read all safety information before operating the equipment. Save these instructions.



Indicates a hazardous situation which, if not avoided, could result in death or serious injury.

To reduce the risks of fire or explosion, electrical shock and the injury to persons, read and understand all instructions included in this manual. Be familiar with the controls and proper usage of the equipment.



WARNING: EXPLOSION OR FIRE

Flammable vapors, such as solvent and paint vapors, in work area can ignite or explode.

PREVENTION:

1. Use equipment only in well ventilated area. Keep a good supply of fresh air moving through the area to keep the air within the spray area free from accumulation of flammable vapors. Keep pump assembly in well ventilated area. Do not spray pump assembly.
2. Do not fill fuel tank while engine is running or hot; shut off engine and allow to cool. Fuel is flammable and can ignite or explode if spilled on a hot surface.
3. Eliminate all ignition sources, such as pilot lights, cigarettes, portable electric lamps and plastic drop cloths (potential static arc).
4. Keep work area free of debris, including solvent, rags and gasoline.
5. Do not plug or unplug power cords, or turn power or light switches on or off when flammable vapors are present.
6. Ground equipment and conductive objects in work area. Make sure the grounding cable is connected from the grounding lug to a true earth ground.
7. Use only grounded hoses.
8. Hold spray gun firmly to the side of a grounded pail when triggering into pail.
9. If there is static sparking or if you feel a shock, **stop operation immediately.**
10. Know the contents of the paint and solvents being sprayed. Read all Material Safety Data Sheets (MSDS) and container labels provided with the paints and solvents. Follow the paint and solvent manufacturer's safety instructions.
11. Do not use a paint or solvent containing halogenated hydrocarbons. Such as chlorine, bleach mildewcide, methylene chloride and trichloroethane. They are not compatible with aluminum. Contact the coating supplier about compatibility of material with aluminum.
12. Keep a fire extinguisher in work area.



WARNING: INJECTION INJURY

A high pressure paint stream produced by this equipment can pierce the skin and underlying tissues, leading to serious injury and possible amputation. See a physician immediately.

PREVENTION:

1. Do not aim the gun at, or spray any person or animal.
2. Keep hands and other body parts away from the discharge. For example, do not try to stop leaks with any part of the body.
3. Always use the nozzle tip guard. Do not spray without the nozzle tip guard in place.

4. Only use a nozzle tip specified by the manufacturer.
5. Use caution when cleaning and changing nozzle tips. In the case where the nozzle tip clogs while spraying, ALWAYS lock gun trigger, shut pump off, and release all pressure before servicing, cleaning tip or guard, or changing tip. Pressure will not be released by turning off the motor. The PRIME/SPRAY valve or pressure bleed valve must be turned to their appropriate positions to relieve system pressure. Refer to PRESSURE RELIEF PROCEDURE described in the pump manual.
6. Do not leave the unit energized or under pressure while unattended. When the unit is not in use, turn off the unit and relieve the pressure in accordance with the manufacturer's instructions.
7. High-pressure spray is able to inject toxins into the body and cause serious bodily injury. In the event that injection occurs, seek medical attention immediately.
8. Check hoses and parts for signs of damage, a leak can inject material into the skin. Inspect hose before each use. Replace any damaged hoses or parts.
9. This system is capable of producing 3300 PSI / 22.8 MPa. Only use replacement parts or accessories that are specified by the manufacturer and that are rated a minimum of 3300 PSI. This includes spray tips, nozzle guards, guns, extensions, fittings, and hose.
10. Always engage the trigger lock when not spraying. Verify the trigger lock is functioning properly.
11. Verify that all connections are secure before operating the unit.
12. Know how to stop the unit and bleed pressure quickly. Be thoroughly familiar with the controls. Pressure will not be released by turning off the motor. The PRIME/SPRAY valve or pressure bleed valve must be turned to their appropriate positions to relieve system pressure. Refer to PRESSURE RELIEF PROCEDURE described in the pump manual.
13. Always remove the spray tip before flushing or cleaning the system.

NOTE TO PHYSICIAN:

Injection into the skin is a traumatic injury which can lead to possible amputation. It is important to treat the injury as soon as possible. DO NOT delay treatment to research toxicity. Toxicity is a concern with some coatings injected directly into the blood stream. Consultation with a plastic surgeon or reconstructive hand surgeon may be advisable.



WARNING: GENERAL

Can cause severe injury or property damage.

PREVENTION:

1. Always wear appropriate gloves, eye protection, clothing and a respirator or mask when painting. Hazardous vapors – Paints, solvents, insecticides, and other materials can be harmful if inhaled or come in contact with body. Vapors can cause severe nausea, fainting or poisoning.
2. Do not operate or spray near children. Keep children away from equipment at all times.
3. Do not overreach or stand on an unstable support. Keep effective footing and balance at all times.
4. Stay alert and watch what you are doing.
5. Do not operate the unit when fatigued or under the influence of drugs or alcohol.
6. Do not kink or over-bend the hose. Airless hose can develop leaks from wear, kinking and abuse. A leak can inject material into the skin.

Important Safety Information

7. Do not expose the hose to temperatures or pressures in excess of those specified by manufacturer.
8. Do not use the hose as a strength member to pull or lift the equipment.
9. Use lowest possible pressure to flush equipment.
10. Follow all appropriate local, state and national codes governing ventilation, fire prevention and operation.
11. The United States Government Safety Standards have been adopted under the Occupational Safety and Health Act (OSHA). These standards, particularly part 1910 of the General Standards and part 1926 of the Construction Standards should be consulted.
12. Before each use, check all hoses for cuts, leaks, abrasion or bulging of cover. Check for damage or movement of couplings. Immediately replace hose if any of those conditions exist. Never repair a paint hose. Replace with a conductive high-pressure hose.
13. Do not spray outdoors on windy days.
14. Always unplug cord from outlet before working on equipment (electric models only).

IMPORTANT: Do not lift cart handle when loading or unloading.

Gasoline Engine Safety



The engine exhaust from this unit contains chemicals known to the State of California to cause cancer, birth defects, or other reproductive harm.

1. Gas engines are designed to give safe and dependable service if operated according to instructions. Read and understand the engine Owner's Manual before operating the engine. Failure to do so could result in personal injury or equipment damage.
2. To prevent fire hazards and to provide adequate ventilation, keep the engine at least 1 meter (3 feet) away from buildings and other equipment during operation. Do not place flammable objects close to the engine.
3. Children and pets must be kept away from the area of operation due to a possibility of burns from hot engine components or injury from any equipment the engine may be used to operate.
4. Know how to stop the engine quickly, and understand the operation of all controls. Never permit anyone to operate the engine without proper instructions.
5. Gasoline is extremely flammable and is explosive under certain conditions.
6. Refuel in a well-ventilated area with the engine stopped. Do not smoke or allow flames or sparks in the refueling area or where gasoline is stored.
7. Do not overfill the fuel tank. After refueling, make sure the tank cap is closed properly and securely.
8. Be careful not to spill fuel when refueling. Fuel vapor or spilled fuel may ignite. If any fuel is spilled, make sure the area is dry before starting the engine.
9. Never run the engine in an enclosed or confined area. Exhaust contains poisonous carbon monoxide gas; exposure may cause loss of consciousness and may lead to death.
10. The muffler becomes very hot during operation and remains hot for a while after stopping the engine. Be careful not to touch the muffler while it is hot. To avoid severe burns or fire hazards, let the engine cool before transporting it or storing it indoors.
11. Never ship/transport unit with gasoline in the tank.

Specifications

Gallons per minute (GPM)	2.2 (8.33 LPM)
Maximum tip sizes	one gun = 0.049"
	two guns = 0.035"
	three guns = 0.027"
	four guns = 0.023"
Maximum pressure	3300 PSI (22.8 MPa)
Power	7.0 HP gas engine
Weight	164 lbs. (74.4 kg)
Maximum hose length	300' (91.4 m)

Table of Contents

Safety Precautions	2
Français	18
Español	20
Specifications	3
General Description	4
Operation	4
Fueling	4
Setup	4
Preparing to Paint.....	5
Painting	6
Pressure Relief Procedure	6
Spraying	7
Spraying Technique	7
Practice	7
Cleanup	8
Maintenance	8
General Repair and Service Notes	8
Maintaining the Engine	9
Replacing the Filter	9
Replacing the PRIME/SPRAY Valve.....	9
Replacing the Potentiometer.....	10
Replacing the Sprayer ON/OFF Switch	10
Replacing the Transducer.....	10
Replacing the Electronic Pressure Control (EPC) Assembly	11
Replacing the Slider Assembly and Slider Housing	11
Replacing the Gears	12
Servicing the Clutch Assembly	13
Servicing the Fluid Section.....	15
Troubleshooting	17
Parts Listings	22
Main Assembly	22
Drive Assembly.....	23
Fluid Section Assembly	24
Cart Assembly	25
Filter Assembly	25
PRIME/SPRAY Assembly	26
5 Gallon Siphon Set (optional)	26
Electrical Schematic.....	27
Labels	27
Accessories.....	27
Limited Warranty	28

General Description

This airless sprayer is a precision power tool used for spraying many types of materials. Read and follow this instruction manual carefully for proper operating instructions, maintenance, and safety information.

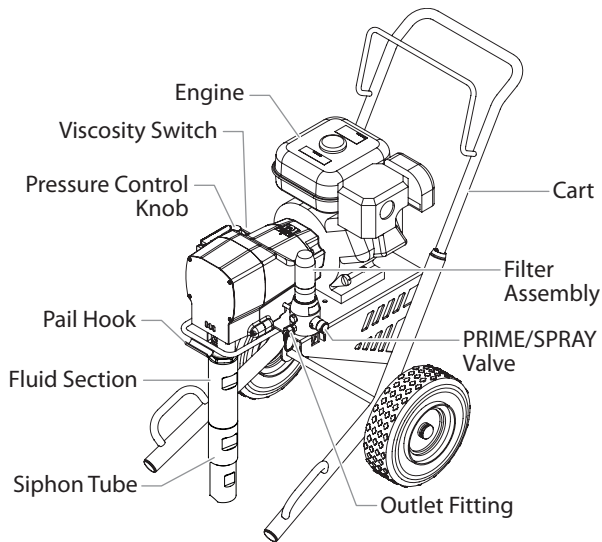

This equipment produces a fluid stream at extremely high pressure. Read and understand the warnings in the Safety Precautions section at the front of this manual before operating this equipment.

Operation

Fueling (gas engine)



Gasoline is extremely flammable and is explosive under certain conditions.

- ALWAYS turn the engine off before refueling.
- Refuel in a well-ventilated area.
- Do not smoke or allow flames or sparks in the refueling area or where gasoline is stored.
- Do not overfill the fuel tank. After refueling, make sure the tank cap is closed properly and securely.
- Be careful not to spill fuel when refueling. Spilled fuel or fuel vapor may ignite. If any fuel is spilled, make sure the area is dry before starting the engine.
- Avoid repeated or prolonged contact with skin or breathing of vapor.
- Keep out of the reach of children.

Fuel Specifications

- Use automotive gasoline that has a pump octane number of 86 or higher, or that has a research octane number of 91 or higher. Use of a lower octane gasoline can cause persistent "pinging" or heavy "spark knock" (a metallic rapping noise) which, if severe, can lead to engine damage.

NOTE: If "spark knock" or "pinging" occurs at a steady engine speed under normal load, change brands of gasoline. If spark knock or pinging persists, consult an authorized dealer of the engine manufacturer. Failure to do so is considered misuse, and damage caused by misuse is not covered by the engine manufacturer's limited warranty.

Occasionally you may experience light spark knock while operating under heavy loads. This is no cause for concern, it simply means your engine is operating efficiently.

- Unleaded fuel produces fewer engine and spark plug deposits and extends the life of the exhaust system components.
- Never use stale or contaminated gasoline or an oil/gasoline mixture. Avoid getting dirt, dust, or water in the fuel tank.

Gasolines Containing Alcohol

If you decide to use a gasoline containing alcohol (gasohol), be sure its octane rating is at least as high as that recommended by the engine manufacturer. There are two types of "gasohol": one containing ethanol, and the other containing methanol. Do not use gasohol that contains more than 10% ethanol. Do not use gasoline containing methanol (methyl or wood alcohol) that does not also contain co-solvents and corrosion inhibitors for methanol. Never use gasoline containing more than 5% methanol, even if it has co-solvents and corrosion inhibitors.

NOTE: Fuel system damage or engine performance problems resulting from the use of fuels that contain alcohol is not covered under the warranty. The engine manufacturer cannot endorse the use of fuels containing methanol since evidence of their suitability is incomplete at this time.

Before buying gasoline from an unfamiliar station, try to find out if the gasoline contains alcohol. If it does, confirm the type and percentage of alcohol used. If you notice any undesirable operating characteristics while using a gasoline that contains alcohol, or one that you think contains alcohol, switch to a gasoline that you know does not contain alcohol.

Setup

Perform the following procedure before starting the engine of a gas-powered sprayer.

1. Ensure that the siphon tube and the return hose are attached and secure.
2. Attach the supplied grounding cable to a grounded object.
3. Using a wrench, attach a minimum of 50' of 3/8" nylon airless spray hose to the 3/8" outlet fitting on the filter assembly. Tighten securely.

NOTE: Use 3/8" spray hose for maximum performance, minimum pressure drop, and minimum pressure fluctuation.

4. Attach an airless spray gun to the spray hose. Using two wrenches (one on the gun and one on the hose), tighten securely.

NOTE: Do not attach the tip to the spray gun yet. Remove the tip if it is already attached.



Make sure all airless hoses and spray guns are electrically grounded and rated at or above the maximum operating pressure range of the airless sprayer.

5. Turn the pressure control knob fully counterclockwise to its lowest pressure setting.
6. Make sure the sprayer ON/OFF switch is in the OFF position.

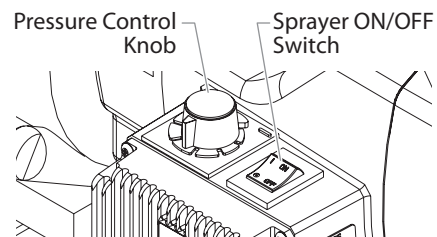

7. Fill the fluid section oil cup with approximately one tablespoon of separating oil (P/N 313-481).

IMPORTANT: Never operate unit for more than ten seconds without fluid. Operating this unit without fluid will cause unnecessary wear to the packings.

8. Check the engine oil level. The gasoline engine oil level is determined by the manufacturer. Refer to the engine manufacturer's service manual (supplied).
9. Close the fuel shut-off lever and fill the gas tank with gasoline. Use only high quality, unleaded gasoline.

Preparing a New Sprayer

If this unit is new, it is shipped with test fluid in the fluid section to prevent corrosion during shipment and storage. This fluid must be thoroughly cleaned out of the system with mineral spirits before you begin spraying.

IMPORTANT: Always keep the trigger lock on the spray gun in the locked position while preparing the system.

1. Place the siphon tube into a container of mineral spirits that has a flash point of 60°C (140°F) or above.
2. Place the return hose into a metal waste container.
3. Turn the pressure control knob fully counterclockwise to its lowest pressure setting.
4. Move the PRIME/SPRAY valve to the PRIME position.
5. Move the engine ON/OFF switch to the ON position.
6. Start the engine:
 - a. Open the fuel valve lever.
 - b. Move the throttle lever away from the gas tank.
 - c. Close the engine choke lever.
 - d. Holding the frame with one hand, pull the starter rope rapidly and firmly. Continue to hold the rope as you let it return. Pull and return the rope until the engine starts.

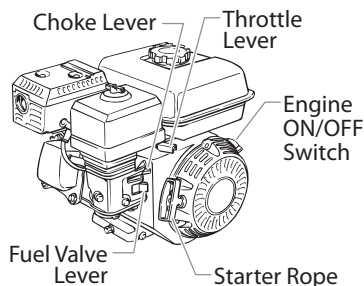

7. Turn on the sprayer by moving the sprayer ON/OFF switch to the ON position.
8. Slowly turn the pressure control knob clockwise to increase the pressure until fluid starts to come out of the return hose. Use only enough pressure to keep the fluid coming out.
9. Allow the sprayer to run for 15–30 seconds to flush the test fluid out through the return hose and into the waste container.
10. Turn the pressure control knob fully counterclockwise to its lowest setting.
11. Turn off the sprayer by moving the sprayer ON/OFF switch to the OFF position.

Preparing to Paint

Before painting, it is important to make sure that the fluid in the system is compatible with the paint that is going to be used.

NOTE: Incompatible fluids and paint may cause the valves to become stuck closed, which would require disassembly and cleaning of the sprayer's fluid section.

IMPORTANT: Always keep the trigger lock on the spray gun in the locked position while preparing the system.

1. Place the siphon tube into a container of the appropriate solvent for the material being sprayed (refer to recommendations of the material manufacturer). An example of the appropriate solvent is water for latex paint.
2. Place the return hose into a metal waste container.
3. Turn the pressure control knob fully counterclockwise to its lowest pressure setting.
4. Move the PRIME/SPRAY valve to the PRIME position.

NOTE: Hold the return hose in the waste container when moving the PRIME/SPRAY valve to PRIME in case the sprayer is pressurized.

5. Move the engine ON/OFF switch to the ON position.
6. Start the engine:
 - a. Open the fuel valve lever.
 - b. Move the throttle lever away from the gas tank.
 - c. Close the engine choke lever.
 - d. Holding the frame with one hand, pull the starter rope rapidly and firmly. Continue to hold the rope as you let it return. Pull and return the rope until the engine starts.
7. Turn on the sprayer by moving the sprayer ON/OFF switch to the ON position.
8. Slowly turn the pressure control knob clockwise to increase the pressure until fluid starts to come out of the return hose. Use only enough pressure to keep the fluid coming out.
9. Allow the sprayer to run for 15–30 seconds to flush the old solvent out through the return hose and into the metal waste container.
10. Turn the pressure control knob fully counterclockwise to its lowest setting.
11. Turn off the sprayer by moving the sprayer ON/OFF switch to the OFF position.

NOTE: Make sure that the spray gun does not have a tip or tip guard installed.

12. Move the PRIME/SPRAY valve to the SPRAY position.
13. Turn on the sprayer.
14. Turn the pressure control knob slowly clockwise to increase pressure.
15. Unlock the gun by turning the gun trigger lock to the unlocked position.



Ground the gun by holding it against the edge of the metal container while flushing. Failure to do so may lead to a static electric discharge, which may cause a fire.

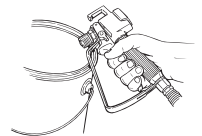

16. Trigger the gun into the metal waste container until the old solvent is gone and fresh solvent is coming out of the gun.
17. Lock the gun by turning the gun trigger lock to the locked position.
18. Set down the gun and increase the pressure by turning the pressure control knob slowly clockwise to its highest setting.
19. Check the entire system for leaks. If leaks occur, turn the sprayer off and follow the "Pressure Relief Procedure" in this manual before tightening any fittings or hoses.
20. Follow the "Pressure Relief Procedure" in this manual before changing from solvent to paint.



Be sure to follow the Pressure Relief Procedure when shutting the unit down for any purpose, including servicing or adjusting any part of the spray system, changing or cleaning spray tips, or preparing for cleanup.

Viscosity Switch - Read before spraying!

Located just below the pressure control knob is the viscosity switch. The switch is designed to ensure proper spray performance depending upon the type of material being sprayed.

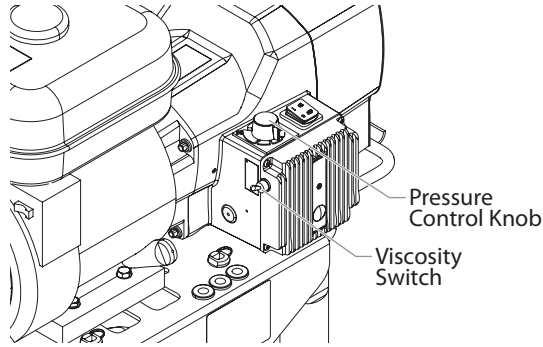

If spraying low to medium-viscosity materials like paint, make sure the switch is toggled to "PAINT" (up).

If spraying heavy-viscosity materials or fillers, make sure the switch is toggled to "FILLER / HEAVY VISCOSITY" (down).

IMPORTANT: It is critical that this switch be used properly. Spraying heavy-viscosity materials when the switch is set to PAINT will put unnecessary stress on the clutch and can cause serious damage to the sprayer.

Painting

1. Place the siphon tube into a container of paint.
2. Place the return hose into a metal waste container.
3. Turn the pressure control knob fully counterclockwise to its lowest pressure setting.
4. Move the PRIME/SPRAY valve to the PRIME position.
5. Move the engine ON/OFF switch to the ON position.
6. Start the engine:
 - a. Open the fuel valve lever.
 - b. Move the throttle lever away from the gas tank.
 - c. Close the engine choke lever.
 - d. Holding the frame with one hand, pull the starter rope rapidly and firmly. Continue to hold the rope as you let it return. Pull and return the rope until the engine starts.
7. Turn on the sprayer by moving the sprayer ON/OFF switch to the ON position.
8. Slowly turn the pressure control knob clockwise to increase the pressure until fluid starts to come out of the return hose. Use only enough pressure to keep the fluid coming out.
9. Allow the sprayer to run until paint is coming through the return hose into the metal waste container.
10. Turn the pressure control knob fully counterclockwise to its lowest setting.
11. Turn off the sprayer by moving the sprayer ON/OFF switch to the OFF position.
12. Remove the return hose from the waste container and place it in its operating position above the container of paint.
13. Move the PRIME/SPRAY valve to the SPRAY position.
14. Turn on the sprayer.
15. Turn the pressure control knob slowly clockwise to increase pressure.
16. Unlock the gun by turning the gun trigger lock to the unlocked position.



Ground the gun by holding it against the edge of the metal container while flushing. Failure to do so may lead to a static electric discharge, which may cause a fire.

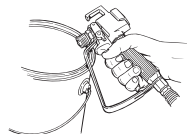

17. Trigger the gun into the metal waste container until all air and solvent is flushed from the spray hose and paint is flowing freely from the gun.
18. Lock the gun by turning the gun trigger lock to the locked position.
19. Turn the pressure control knob fully counterclockwise to its lowest setting.
20. Turn off the sprayer.
21. Attach tip guard and tip to the gun as instructed by the tip guard or tip manuals.



POSSIBLE INJECTION HAZARD. Do not spray without the tip guard in place. Never trigger the gun unless the tip is in either the spray or the unclog position. Always engage the gun trigger lock before removing, replacing or cleaning tip.

22. Turn on the sprayer.
23. Increase the pressure by turning the pressure control knob slowly clockwise and test the spray pattern on a piece of cardboard. Adjust the pressure control knob until the spray from the gun is completely atomized. Try to keep the pressure control knob at the lowest setting that maintains good atomization.

NOTE: Turning the pressure up higher than needed to atomize the paint will cause premature tip wear and additional overspray.

Pressure Relief Procedure



Be sure to follow the Pressure Relief Procedure when shutting the unit down for any purpose, including servicing or adjusting any part of the spray system, changing or cleaning spray tips, or preparing for cleanup.

1. Lock the gun by turning the gun trigger lock to the locked position.
2. Turn off the sprayer by moving the sprayer ON/OFF switch to the OFF position.
3. Turn off the engine by moving the engine ON/OFF switch to the OFF position.
4. Turn the pressure control knob counterclockwise to its lowest setting.
5. Unlock the gun by turning the gun trigger lock to the unlocked position.
6. Hold the metal part of the gun firmly to the side of a metal container to ground the gun and avoid a build up of static electricity.
7. Trigger the gun to remove any pressure that may still be in the hose.
8. Lock the gun by turning the gun trigger lock to the locked position.
9. Move the PRIME/SPRAY valve to the PRIME position.

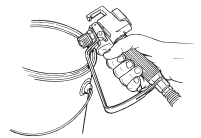

Spraying

NOTE: When spraying block filler, mastics or high solid coating, remove the gun filter and high pressure filter screens.

Spraying Technique

The key to a good paint job is an even coating over the entire surface. This is done by using even strokes. Keep your arm moving at a constant speed and keep the spray gun at a constant distance from the surface. The best spraying distance is 10 to 12 inches between the spray tip and the surface.

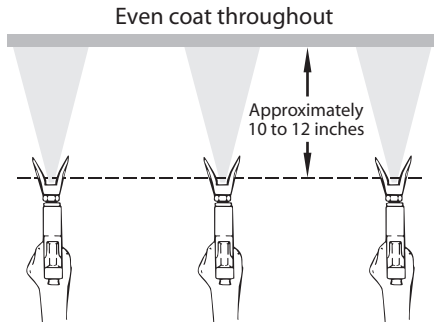

Keep stroke smooth and at an even speed.

Keep the spray gun at right angles to the surface. This means moving your entire arm back and forth rather than just flexing your wrist.

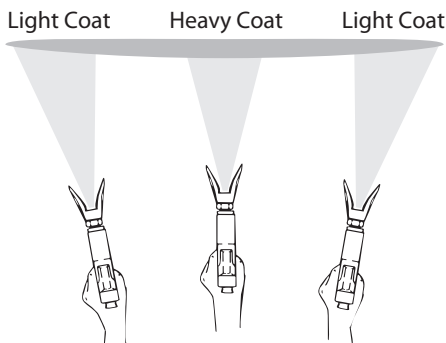

Do not flex wrist while spraying.

Keep the spray gun perpendicular to the surface, otherwise one end of the pattern will be thicker than the other.

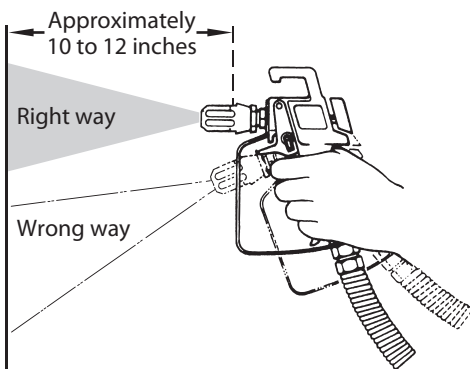

The spray gun should be triggered by turning it on and off with each stroke. This will save paint and avoid paint buildup at the end of the stroke. Do not trigger the gun during the middle of a stroke. This will result in an uneven spray and splotchy coverage.

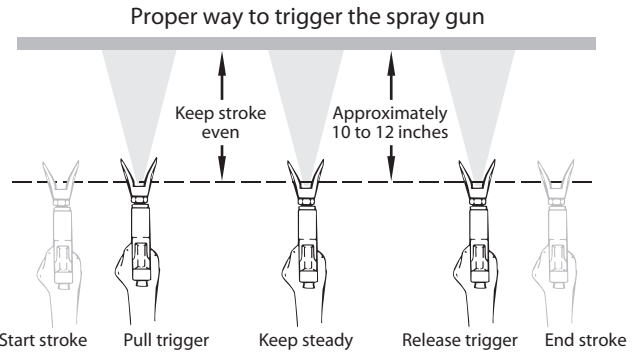

Overlap each stroke by about 30%. This will ensure an even coating. When you stop painting, lock the gun trigger lock, turn the pressure control knob counterclockwise to its lowest setting and set the PRIME/SPRAY valve to PRIME. Turn the ON/OFF switch to the OFF position and unplug the sprayer.

Practice

1. Be sure that the paint hose is free of kinks and clear of objects with sharp cutting edges.
2. Turn the pressure control knob counterclockwise to its lowest setting.
3. Move the PRIME/SPRAY valve to the SPRAY position.
4. Turn the pressure control knob clockwise to its highest setting. The paint hose should stiffen as paint begins to flow through it.
5. Unlock the gun trigger lock.
6. Trigger the spray gun to bleed air out of the hose.
7. When paint reaches the spray tip, spray a test area to check the spray pattern.
8. Use the lowest pressure setting necessary to get a good spray pattern. If the pressure is set too high, the spray pattern will be too light. If the pressure is set too low, tailing will appear or the paint will spatter out in gobs rather than in a fine spray.

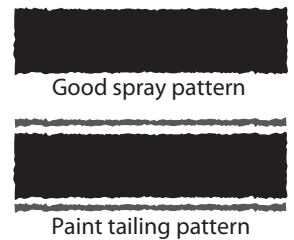

Cleanup



Special cleanup instructions for use with flammable solvents:

- Always flush spray gun preferably outside and at least one hose length from spray pump.
- If collecting flushed solvents in a one gallon metal container, place it into an empty five gallon container, then flush solvents.
- Area must be free of flammable vapors.
- Follow all cleanup instructions.

IMPORTANT: The sprayer, hose, and gun should be cleaned thoroughly after daily use. Failure to do so permits material to build up, seriously affecting the performance of the unit.



Always spray at minimum pressure with the gun nozzle tip removed when using mineral spirits or any other solvent to clean the sprayer, hose, or gun. Static electricity buildup may result in a fire or explosion in the presence of flammable vapors.

1. Follow the "Pressure Relief Procedure" found in the Operation section of this manual.
2. Remove the gun tip and tip guard and clean with a brush using the appropriate solvent.
3. Place the siphon tube into a container of the appropriate solvent (refer to recommendations of the material manufacturer). An example of the appropriate solvent is water for latex paint.
4. Place the return hose into a metal waste container.
5. Move the PRIME/SPRAY valve to its PRIME position.

NOTE: Hold the return hose in the waste container when moving the PRIME/SPRAY valve to PRIME in case the sprayer is pressurized.

6. Move the engine ON/OFF switch to the ON position and start the engine.
7. Turn on the sprayer by moving the sprayer ON/OFF switch to the ON position.
8. Slowly turn the pressure control knob clockwise to increase the pressure until fluid starts to come out of the return hose.
9. Allow the solvent to circulate through the sprayer and flush the paint out of the return hose into the metal waste container.
10. Turn the pressure control knob fully counterclockwise to its lowest setting.
11. Turn off the sprayer by moving the ON/OFF switch to the OFF position.
12. Move the PRIME/SPRAY valve to its SPRAY position.
13. Turn on the sprayer.
14. Turn the pressure control knob slowly clockwise to increase pressure.



Ground the gun by holding it against the edge of the metal container while flushing. Failure to do so may lead to a static electric discharge, which may cause a fire.

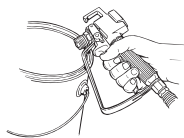

15. Trigger the gun into the metal waste container until the paint is flushed out of the hose and solvent is coming out of the gun.
16. Continue to trigger the spray gun into the waste container until the solvent coming out of the gun is clean.

NOTE: For long-term or cold weather storage, pump mineral spirits through the entire system.

17. Follow the "Pressure Relief Procedure" found in the Operation section of this manual.
18. Store the sprayer in a clean, dry area.

IMPORTANT: Do not store the unit under pressure.

Cleaning the Spray Tip

1. Flush the gun with solvent immediately after the work is completed.
2. Oil the sliding pins to prevent them from seizing up.



Should the spray tip become clogged, reverse the spray tip with the lever and pull the trigger. Once the obstruction comes out of the spray tip, release the trigger, reverse the spray tip back to the spray pattern setting, and resume spraying.



Do not attempt to clean the tip with your finger. Do not use a needle or other sharp pointed instrument to clean the tip. The hard tungsten carbide is brittle and can be chipped.

Maintenance



Before proceeding, follow the Pressure Relief Procedure outlined previously in this manual. Additionally, follow all other warnings to reduce the risk of an injection injury, injury from moving parts or electric shock.

NOTE: All Robin-Subaru engine work should be performed by a Robin-Subaru authorized service center.

General Repair and Service Notes

The following tools are needed when repairing this sprayer:

Phillips screwdriver	3/8" hex wrench
needle-nose pliers	5/16" hex wrench
adjustable wrench	1/4" hex wrench
rubber mallet	3/16" hex wrench
flat-blade screwdriver	1/8" hex wrench
1/2" open-end wrench	7/8" open-end wrench

1. Before repairing any part of the sprayer, read the instructions carefully, including all warnings.

IMPORTANT: Never pull on a wire to disconnect it. Pulling on a wire could loosen the connector from the wire.

2. Test your repair before regular operation of the sprayer to be sure that the problem is corrected. If the sprayer does not operate properly, review the repair procedure to determine if everything was done correctly. Refer to the Troubleshooting section to help identify other possible problems.
3. Make certain that the service area is well ventilated in case solvents are used during cleaning. Always wear protective eyewear while servicing. Additional protective equipment may be required depending on the type of cleaning solvent. Always contact the supplier of solvents for recommendations.
4. If you have any further questions concerning your titan airless sprayer, call titan:

Technical Service (U.S.)..... **1-800-526-5362**

Fax **1-800-528-4826**

Maintaining the Engine



When transporting a sprayer with a gas engine, make sure the fuel is shut off.

NOTE: For detailed engine specifications and maintenance, refer to the separate engine manual supplied with this sprayer.

Important Facts Concerning this Sprayer

This gas-powered sprayer contains a clutch that engages when the sprayer is pumping. The sprayer's pressure control system engages and disengages the clutch to control pressure. To prevent unnecessary wear to the clutch, it is advisable to adjust the engine speed and pressure setting to limit the amount of times the clutch engages and disengages. To reduce clutch wear, refer to the following examples.

Example:

Operating one gun with a .019 tip — reduce the engine speed by adjusting the throttle to a low or medium setting and increase pressure only until the heavy ends of the spray pattern have been eliminated.

Example:

Operating one gun with .023 tip — increase engine speed to a higher setting and increase pressure until the heavy ends of the spray pattern have been eliminated.

Example:

Spraying light-bodied materials at low pressure — to reduce surging at the gun and to decrease clutch wear, reduce the engine speed to idle and reduce pressure until the desired spray pattern is achieved.

Routine Engine Maintenance

Daily

- Check and fill the gas tank.
- After the first 20 hours of operation, drain the oil and refill with clean oil. Check the engine oil level and fill as necessary.

Weekly

- Remove the cover of the air filter and clean the element. Replace the element if necessary. If operating in an unusually dusty environment, check the filter daily and replace if necessary. (Replacement elements can be purchased from your local Titan dealer.)
- After each 50 hours of operation: Change the engine oil.

Spark Plug

- Use only a (NKG) BP6ES plug.
- Gap the plug 0.025" – 0.030" (0.7 – 0.8 mm).
- Make sure to use a spark plug wrench when installing and removing the plug.

Replacing the Filter

1. Loosen and remove the filter body by hand.
2. Remove the filter and filter support spring from the filter housing.
3. Remove the filter support spring and adapter from inside the filter.
4. Inspect the filter. Based on inspection, clean or replace the filter.
5. Inspect the filter housing o-ring. Based on inspection, clean or replace the o-ring.
6. Slide the new or cleaned filter over the adapter and filter support spring. Place the filter and filter support spring into the center of the filter housing.
7. Clean the inside of the filter body.
8. Slide the filter body over the filter and thread it into the filter housing until secure. Make sure the filter spring is in position on top of the filter.

NOTE: The filter body should be hand-tightened, but make sure it is seated fully into the filter housing.

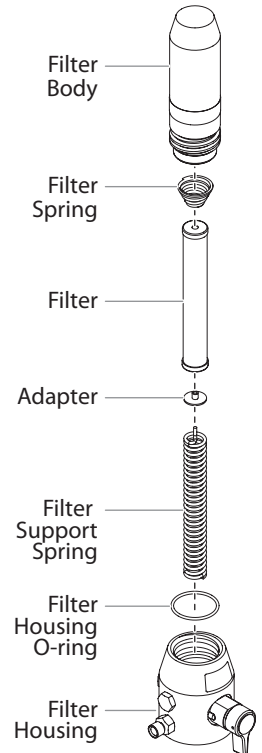

Replacing the PRIME/SPRAY Valve

Perform the following procedure using PRIME/SPRAY valve replacement kit P/N 0507690.

1. Drive the groove pin out of the valve handle.
2. Remove the valve handle and the cam base.
3. Using a wrench, loosen and remove the valve housing assembly.
4. Make sure the gasket is in place and thread the new valve housing assembly into the filter housing. Tighten securely with a wrench.
5. Place the cam base over the valve housing assembly. Lubricate the cam base with grease and line up the cam with the filter block using the dowel pin.
6. Line up the hole on the valve stem with the hole in the valve handle.
7. Insert the groove pin into the valve handle and through the valve stem to secure the valve handle in position.

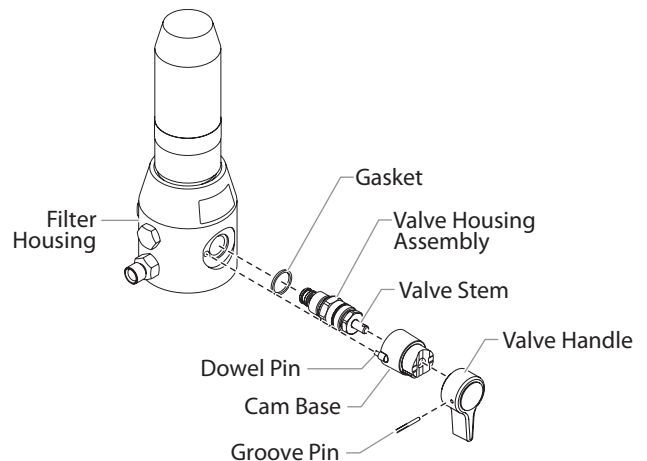

Replacing the Potentiometer



Electrostatic discharge (ESD) potential could cause damage to electronic pressure control. Use Titan ESD wrist strap P/N 0507958 or equivalent when working on electronic pressure control.

1. Perform the Pressure Relief Procedure.
2. Pry off the pressure control knob cap to expose the knob tension nut.
3. Turn the pressure control knob fully counterclockwise to the minimum pressure setting.
4. Using a 5/16" socket, loosen the tension nut in the center of the knob. Remove the knob.
5. Using a Phillips screwdriver, remove the four screws that secure the electronic pressure control (EPC) assembly to the EPC housing. Carefully remove the EPC assembly from the housing. Gently move the assembly away from the sprayer and allow the assembly to hang from the housing.

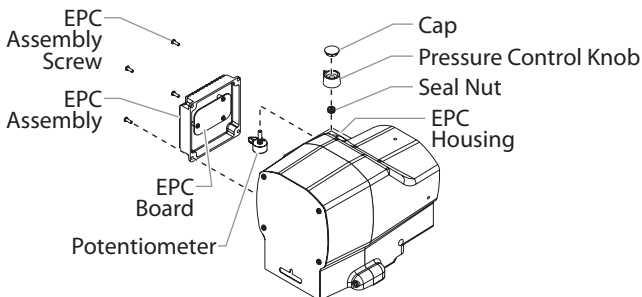

6. Hold the potentiometer inside the EPC housing while using a 1/2" thin wall socket to remove the seal nut that secures the potentiometer to the mounting plate. Remove the potentiometer from the EPC housing.
7. Carefully remove the potentiometer wires from their connection point on the EPC board.
8. Insert the stem of the new potentiometer through the hole in the mounting plate from inside the EPC housing. Position the protruding tab on the potentiometer face into the hole on the underside of the mounting plate (the wires will face the open side of the EPC housing).
9. Thread the seal nut onto the threaded portion of the stem and tighten using a 1/2" thin wall socket.

IMPORTANT: Do not over-tighten the seal nut.

10. Turn the potentiometer stem fully counterclockwise.
11. Place the pressure control knob on the potentiometer stem with the indicator tab resting at the "minimum pressure" tab on the mounting plate.
12. Tighten the knob tension nut using a 5/16" socket.

IMPORTANT: Do not over-tighten the knob tension nut. Over-tightening will damage the potentiometer.

13. Connect the potentiometer wires to the EPC board. The protruding tab on the EPC board connector will mate with the slot on the potentiometer wires connector. The connector on the end of the potentiometer wires and the connector on the EPC board will mate only one way. Do not force the connectors together.
14. Carefully place the EPC assembly over the EPC housing taking care not to pinch any wires.
15. Install the four screws that secure the EPC assembly to the EPC housing. Tighten securely.

Replacing the Sprayer ON/OFF Switch



Electrostatic discharge (ESD) potential could cause damage to electronic pressure control. Use Titan ESD wrist strap P/N 0507958 or equivalent when working on electronic pressure control.

1. Perform the Pressure Relief Procedure.
2. Using a Phillips screwdriver, remove the four screws that secure the electronic pressure control (EPC) assembly to the EPC housing. Carefully remove the EPC assembly from the housing. Gently move the assembly away from the sprayer and allow the assembly to hang from the housing.
3. Locate the bottom of the sprayer ON/OFF switch inside the EPC housing.

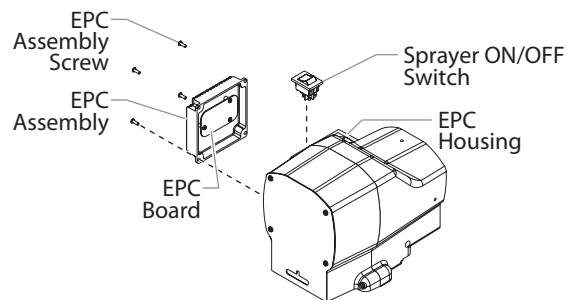

4. Disconnect the switch wires from the sprayer ON/OFF switch. Remember the locations of each of the two wires (label the wires, if necessary).
5. Depress the mounting tabs on each corner of the sprayer ON/OFF switch inside the EPC housing and remove the switch through the top of the housing.
6. Snap the new sprayer ON/OFF switch into the switch hole in the EPC housing.
7. Connect the two switch wires to the new sprayer ON/OFF switch. Make sure the wires are connected to the corresponding terminals from which they were removed (refer to the labels created earlier in this procedure or the electrical schematic in the Parts List section of this manual).
8. Carefully place the EPC assembly over the EPC housing taking care not to pinch any wires.
9. Install the four screws that secure the EPC assembly to the EPC housing. Tighten securely.

Replacing the Transducer



Electrostatic discharge (ESD) potential could cause damage to electronic pressure control. Use Titan ESD wrist strap P/N 0507958 or equivalent when working on electronic pressure control.

1. Perform the Pressure Relief Procedure.
2. Using a Phillips screwdriver, remove the four screws that secure the electronic pressure control (EPC) assembly to the EPC housing. Carefully remove the EPC assembly from the housing. Gently move the assembly away from the sprayer and allow the assembly to hang from the housing.
3. Locate the transducer wire in the EPC housing. This wire will be protruding from a hole in the lower left hand corner of the EPC housing. Disconnect this wire from the EPC board (it has a phone jack-style connector).
4. Break off the locking tab from the phone jack-style connector at the end of the transducer wire.
5. Using a 7/8" open-end wrench, loosen and remove the fluid hose from the fitting on the bottom of the filter assembly.

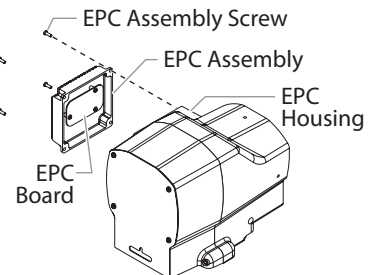

6. Using a 9/16" open-end wrench, loosen and remove the return hose from the bottom of the filter assembly.
7. Using a 1/2" socket, remove the two hex screws that secure the filter assembly to the cart.
8. Lift the filter assembly off the cart so that the transducer tube moves out of the hole in the gear housing. Gently pull the transducer wire through the housing until it is fully disengaged from the hole.
9. Mount the filter assembly in a vise for easy access to the transducer.

IMPORTANT: Do not over-tighten the vise.

10. Using a 3/4" open-end wrench, turn the transducer nut counterclockwise to remove the transducer from the filter housing.
11. Locate the new transducer. Make sure that there is a white, PTFE o-ring on the end of the transducer that gets inserted into the filter housing.
12. Insert the transducer into the filter housing port. Rotate the transducer nut clockwise to tighten it into the filter housing. Torque the nut to 360–400 in./lbs.
13. Remove the filter assembly from the vise.

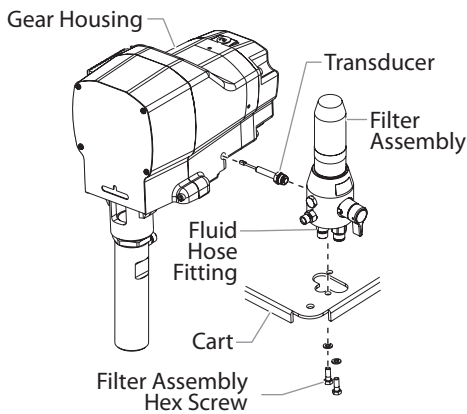

14. Insert the phone jack-style connector on the new transducer wire into the hole in the gear housing from which the old transducer wire was removed. Push the wire and connector until the connector is visible in the EPC housing.
15. Gently pull the wire into the EPC housing while moving the filter assembly to its mounting point on the cart. Guide the end of the transducer tube into the hole in the gear housing.
16. Mount the filter assembly to the cart using the two hex screws and lock washers. Torque the screws to 100–130 in.-lbs.
17. Using a 7/8" open-end wrench, attach the fluid hose to the fitting on the bottom of the filter assembly. Tighten securely.
18. Using a 9/16" open-end wrench, attach the return hose to the bottom of the filter assembly. Tighten securely.
19. Plug the phone jack-style connector on the transducer wire into the socket on the EPC board from which the old connector was removed.
20. Carefully place the EPC assembly over the EPC housing taking care not to pinch any wires.
21. Install the four screws that secure the EPC assembly to the EPC housing. Tighten securely.
22. Take the sprayer to a Titan Authorized Service Center for re-calibration.
23. After re-calibration, pressurize the system and check for leaks.

Replacing the Electronic Pressure Control (EPC) Assembly



Electrostatic discharge (ESD) potential could cause damage to electronic pressure control. Use Titan ESD wrist strap P/N 0507958 or equivalent when working on electronic pressure control.

1. Perform the Pressure Relief Procedure.
2. Using a Phillips screwdriver, remove the four screws that secure the electronic pressure control (EPC) assembly to the EPC housing. Carefully remove the EPC assembly from the housing. Gently move the assembly away from the sprayer and allow the assembly to hang from the housing.
3. Remember the locations of all the wire connections on the EPC board (refer the electrical schematic located in the Parts List section of this manual). If necessary, label all the connections so that they can be replaced in their exact location when the assembly is replaced.
4. Disconnect all the wires from the EPC board.
5. Connect all the wires to the new EPC assembly board (refer to the labels created earlier in this procedure or the electrical schematic in the Parts List section of this manual).
6. Carefully place the EPC assembly over the EPC housing taking care not to pinch any wires.
7. Install the four screws that secure the EPC assembly to the EPC housing. Tighten securely.
8. Take the sprayer to a Titan Authorized Service Center for re-calibration.

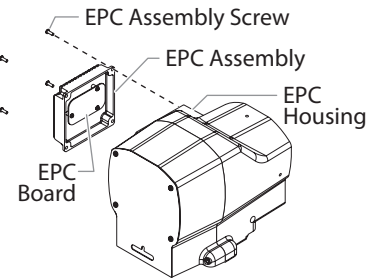

Replacing the Slider Assembly and Slider Housing

1. Start the engine (refer to the procedures in the Operation section of this manual). Turn the pressure control knob clockwise to its maximum pressure setting.
2. Toggle the sprayer ON/OFF switch between the ON and OFF positions in short bursts until the slider assembly stops in a position where the fluid section connecting pin and retaining ring are visible through the slot in the slider housing.
3. Turn off the engine and perform the Pressure Relief Procedure.
4. Using a Phillips screwdriver, remove the four front cover screws. Remove the front cover.
5. Slide the retaining ring up on the slider assembly to expose the connecting pin.
6. Push the connecting pin forward through the slider assembly and piston. The connecting pin will fall out from the rear window of the slider housing where it can be retrieved.
7. Using a 7/8" open-end wrench, loosen and remove the fluid hose from the fitting on the back of the fluid section.
8. Using a 21/4" wrench, loosen the fluid section jam nut. Turn the fluid section counterclockwise by until it disengages from the slider housing.

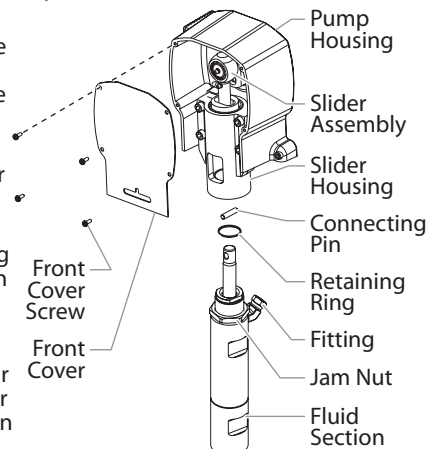

9. Using a 5/16" hex wrench, remove the four socket screws and lock washers that secure the slider housing to the pump housing.
10. Remove the slider housing and slider assembly by pulling it straight out from the pump housing. The slider housing assembly will disengage from the pump housing dowel pins and the connecting rod will disengage from the crankshaft.
11. Remove the slider assembly from the slider housing by grasping the bearing end of the connecting rod and lifting it straight out from the slider housing.
12. Check the parts for wear.
 - a. If the slider housing bushing is scored or out of round it should be replaced.
 - b. If the slider assembly is scored or the connection between the connecting rod and slider assembly exhibits movement other than pivoting movement, the slider assembly should be replaced. The slider assembly also should be replaced if the connecting rod bearing shows signs of wear.
 - c. Any parts that will be reused should be cleaned thoroughly, including the connecting rod. Also, clean the crankshaft pin that the connecting rod bearing rides on.
 - d. If a new slider assembly will be used, remove the retaining ring from the bottom of the old slider assembly and slide it onto the new assembly so that it rests above the connecting pin hole.
13. Lubricate the inside diameter of the slider housing and the outside diameter of the slider assembly with oil. Fill the slider cup with Lubriplate 3000W grease (the slider cup is the area on the slider assembly where the connecting rod and slider housing join and pivot).
14. Insert the slider assembly into the bushing end of the slider housing.

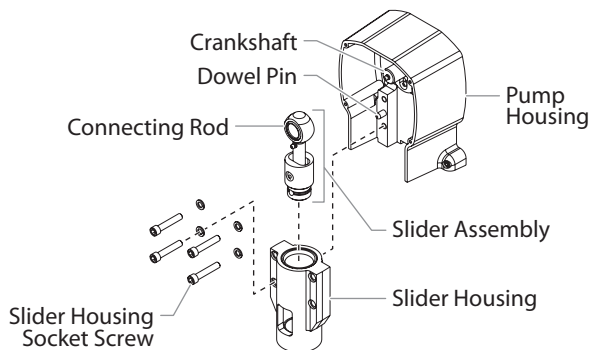

15. Hold the assembly up to the pump housing, lining up the connecting rod with the crankshaft pin and the pump housing dowel pins with their mating holes on the slider housing. Slide the assembly onto the crankshaft pin and pump housing dowel pins until the slider housing bottoms out on the pump housing. Make sure the grease fitting on the connecting rod is facing the open side of the pump housing.
16. Install the the four socket screws and lock washers that secure the slider housing to the pump housing. Tighten in a diagonal pattern and torque to 400–440 in./lbs.
17. Lubricate the connecting rod bearing with Lubriplate 1242 grease by inserting the end of a grease gun onto the grease fitting on the end of the crankshaft pin. Lubricate the main housing bearing by inserting the end of a grease gun onto the grease fitting in the center of the crankshaft. Also, lubricate the connecting rod bushing by inserting the end of a grease gun onto the grease fitting on the connecting rod.
18. Position the front cover over the pump housing. Secure the front cover using the four front cover screws.
19. Apply blue Loctite to the bottom 3–4 threads on the fluid section cylinder.
20. Turn the fluid section jam nut clockwise until it is flush against the top of the cylinder.
21. Lubricate the first several threads at the top of the cylinder with anti-seize compound.
22. Thread the cylinder into the pump housing, turning clockwise. When the connecting pin hole on the piston rod lines up with the hole in the slider assembly, insert the connecting pin.

23. Slide the retaining ring down on the slider assembly to cover the connecting pin.
24. Continue to turn the cylinder clockwise until the jam nut is flush against the slider housing.

NOTE: If the nipple on the cylinder does not face the back of the unit, turn the cylinder counterclockwise until the nipple faces the back of the unit. Do not turn the cylinder more than one full turn.

25. Once the nipple is positioned, turn the jam nut clockwise until it contacts the pump housing.
26. Tighten the jam nut with a wrench to tighten it against the slider housing.
27. Using a 7/8" open-end wrench, attach the fluid hose to the fitting on the back of the fluid section. Tighten securely.

Replacing the Gears

1. Perform the Pressure Relief Procedure.
2. Using a Phillips screwdriver, remove the four front cover screws. Remove the front cover..
3. Using a 7/8" open-end wrench, loosen and remove the fluid hose from the fitting on the back of the fluid section.
4. Locate the four socket screws that secure the pump housing to the gear housing. Two are at the inside top of the pump housing and two are located on the external bosses at the bottom of the pump housing.
5. Using a 1/4" hex wrench, remove the four socket screws that secure the pump housing to the gear housing.
6. Slide the pump housing assembly away from the gear housing.
7. Remove and clean the housing gasket. Replace if damaged.
8. Remove the gear assembly and the 1/4" thrust balls from within the bearing bores that support the gear.

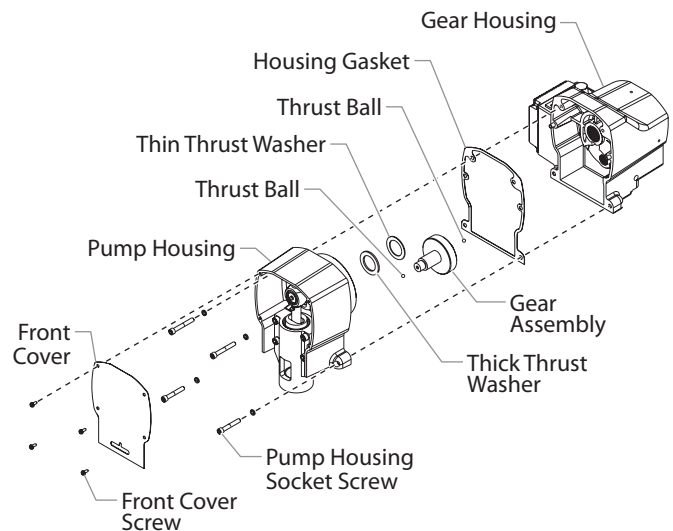

9. Inspect the gears for excessive wear and replace if damaged or worn. If the gear assembly is replaced, replace the two thrust balls as well.
10. Inspect the pinion gear on the end of the drive shaft for wear. Replace if damaged or worn (refer to the "Servicing the Clutch Assembly" procedure in this section).
11. Inspect the output gear and the two thrust washers on the end of the crankshaft in the pump housing for wear. This gear is permanently attached to the crankshaft and pump housing. If this gear is worn, the pump housing must be replaced.

NOTE: If replacing the pump housing, first remove the fluid section, slider housing, and slider assembly from the pump housing (refer to the "Replacing the Slider and Slider Housing" procedure in this section).

- Replace the thrust washers if worn. If the pump housing assembly is replaced, replace the thrust washers as well.

NOTE: If any of the gears are worn and require replacement, check the grease in the gear housing for metal particles or shavings. Remove the contaminated grease. Replace the grease that has been removed with fresh Lubriplate GR-132 grease.

- Coat each of the thrust balls with a generous amount of grease. Install the thrust balls — one in the gear housing bore and one in the pump housing bore.
- Coat the gear assembly with fresh Lubriplate GR-132 grease. Insert the gear assembly into the bore in the pump housing, pinion end first.
- Generously coat both faces of each of the crankshaft thrust washers with grease.
- Place the thick thrust washer onto the crankshaft up against the gear hub. Next, place the thin thrust washer up against the thick washer on the crankshaft.
- Place the housing gasket over the gear housing dowel pins.
- Carefully place the pump housing assembly in front of the gear housing assembly, lining up the gear housing dowel pins with their corresponding holes in the pump housing. Slide the pump housing onto the gear housing until there is no gap between the housings and gasket.

IMPORTANT: Do not force the pump housing and gear housing together.

- Locate the four socket screws and lock washers that secure the pump housing to the gear housing. The longer screws (2.25") are fastened into the top internal holes. The shorter screws (2") are fastened into the bottom external bosses.
- Using a 1/4" hex wrench, snug and tighten the socket screws in a crossing pattern. Torque to 200–230 in.-lbs.
- If the slider, slider housing, and fluid section were removed, reinstall by following the steps in the "Replacing the Slider and Slider Housing" procedure in this section.
- Position the front cover over the pump housing. Secure the front cover using the four front cover screws.
- Using a 7/8" open-end wrench, attach the fluid hose to the fitting on the back of the fluid section. Tighten securely.

Servicing the Clutch Assembly

NOTE: When replacing the clutch armature, the clutch hub and clutch rotor must be replaced also. This will allow for even wear and maximum life on clutch parts.

Removing/Replacing the Clutch Hub and Armature Assembly

- Perform the Pressure Relief Procedure.
- Using a 7/8" open-end wrench, loosen and remove the fluid hose from the fitting on the back of the fluid section.
- Hold the transducer tube with a pliers to prevent it from rotating and turn the transducer nut counterclockwise using a 3/4" open-end wrench. When the nut disengages the filter housing, carefully remove the transducer from the filter housing.
- Locate the wire that exits the rear of the electronic pressure control (EPC) housing and connects to the wire harness on the engine. Disconnect this wire from its connector at the engine wire harness.
- Using a 1/2" wrench, remove the four hex screws and lock washers that secure the clutch housing to the gear housing.
- Using a 9/16" socket, remove the two hex screws that secure the gear housing to the cart.
- Slide the pump and gear housings away from the engine to disengage them from the clutch housing.

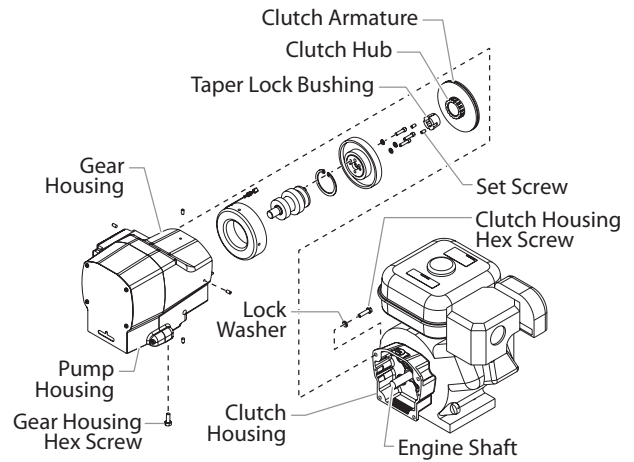

- Locate the clutch hub and armature assembly on the end of the engine shaft. Note the two set screws as well as the unused, threaded hole in the taper lock bushing at the center of the clutch hub.
- Using an 1/8" hex wrench, remove the two set screws from the taper lock bushing.
- Thread one of the set screws into the unused, threaded hole on the taper lock bushing. As the screw tightens, the bushing will loosen. Once the bushing has loosened enough, slide the clutch hub and armature assembly off the engine shaft.
- Before replacing the clutch hub and armature assembly the proper "set back" must be created. Using the Titan hub set-up tool (P/N 0509925), create a "set back" of 0.20" between the friction surface of the clutch armature and the forward face of the clutch hub.

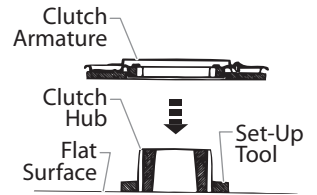

NOTE: A new clutch hub and armature assembly will come pre-assembled, but the "set back" will not be correct. The "set back" must still be created using the hub set-up tool.

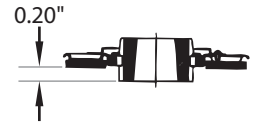

- Line up the three holes in the taper lock bushing with the three holes in the clutch hub and insert the bushing into the center of the clutch hub.
- Line up the key on the taper lock bushing with the keyway on the engine shaft and slide the assembly onto the shaft with the holes facing out.
- Apply blue Loctite to the two set screws and insert the screws into the taper lock bushing. Tighten the set screws only two turns at this time.
- Line up the forward face of the clutch hub with the front face of the clutch housing. Using an 1/8" hex wrench, alternately tighten the set screws into the taper lock bushing. Torque to 65–75 in-lbs.

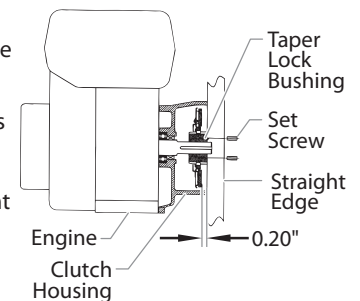

NOTE: To ensure the clutch hub and the clutch housing are aligned, hold a straight edge across the face of the clutch housing and then hold the clutch hub against the back of the straight edge while tightening the two set screws into the taper lock bushing.

- Make sure the friction surface of the clutch armature is clean and free from oil or grease.

Removing the Clutch Rotor, Clutch Field, and Drive Shaft Assembly

1. Follow steps 1–7 in “Removing/Replacing the Clutch Hub and Armature Assembly.”
2. Locate the clutch rotor assembly on the end of the drive shaft assembly. Note the locations of the three socket screws and the two empty, threaded holes on the clutch rotor.
3. Using a 3/16” hex wrench, remove the three socket screws and lock washers that secure the clutch rotor to the drive shaft assembly.
4. Thread two of the socket screws into the empty, threaded holes and tighten alternately. This will push the clutch rotor away from the drive shaft assembly and pinion.



Electrostatic discharge (ESD) potential could cause damage to electronic pressure control. Use Titan ESD wrist strap P/N 0507958 or equivalent when working on electronic pressure control.

5. Using a Phillips screwdriver, remove the four screws that secure the EPC assembly to the EPC housing. Carefully remove the EPC assembly from the housing.
6. Locate the two clutch field wires that pass from the gear housing into the EPC housing through a grommet in the back of the EPC housing. Remember the wire connection terminals on the EPC assembly (label if necessary) and disconnect the wires. Gently move the EPC assembly away from the housing and rest it on the work surface by the control housing.
7. Locate the four set screws that secure the clutch field to the gear housing. They are located on the exterior of the gear housing at the 12, 3, 6, and 9 o’clock positions while facing the clutch field end of the gear housing. Using an 1/8” hex wrench, remove the setscrews. Remember the location of the two clutch field wires with respect to the grommet and EPC housing.
8. Carefully slide the clutch field out of the gear housing, keeping the field square to the gear housing so it does not bind.
9. Remove the retaining ring in front of the ball bearing within the center bore of the gear housing.
10. Follow steps 2–6 in the “Replacing the Gears” procedure to remove the pump housing from the gear housing.
11. From the gear side of the gear housing, use a soft hammer to tap the gear end of the drive shaft through the gear housing.
12. Carefully slide the drive shaft assembly out from the gear housing, keeping the shaft square to the housing so it does not bind.
13. Remove the o-ring from inside the center bore of the gear housing from which the small ball bearing on the drive shaft assembly was removed.
14. Clean the inside of the gear housing.

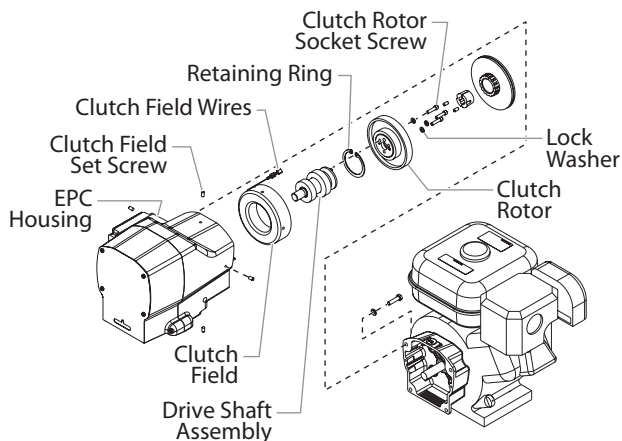

Installing the Clutch Rotor Assembly, Clutch Field and Drive Shaft Assembly

1. Install a new o-ring into the center bore of the gear housing.
2. Apply Loctite retaining compound #635 to the outside diameter of the large bearing on the drive shaft. Do not get retaining compound on the faces of the bearing.
3. Install the drive shaft assembly into the center bore of the gear housing, keeping it square to the housing so it does not bind. Once the large ball bearing on the drive shaft assembly is half way into its bore, a soft hammer may be used to gently tap the assembly into position.

IMPORTANT: Do not force the drive shaft assembly into position.

4. Install the retaining ring into its groove next to the large ball bearing.
5. Line up the four holes around the outside of the clutch field with the four set screw holes in the gear housing. The clutch field wires should be at approximately the 1 or 2 o’clock position.
6. Route the two clutch field wires through the grommet and into the EPC housing.
7. Carefully slide the clutch field into its bore in the gear housing until it “bottoms out” within the housing. Do not pinch the clutch field wires during installation.

NOTE: Apply blue Loctite to the four clutch field set screws prior to installation.

8. Thread one of the set screws into its hole. Using an 1/8” hex wrench, rotate the screw slowly until it contacts the clutch field. Do not tighten the set screw. The tip of the set screw should mate with the drill point hole in the field. Check the clutch field for rotation. If it rotates within its bore, the set screw is not seated within the drill point.
9. When the set screw is properly seated, install the remaining three set screws. Do not tighten the set screws.
10. Using a crossing pattern, tighten each of the setscrews until they are snug. Once all four set screws are snug, use a crossing pattern to tighten and torque the set screws to 30–40 in.-lbs.

IMPORTANT: It is very important to evenly snug, tighten, and torque the clutch field set screws in a crossing pattern. This ensures the clutch field will stay centered in the gear housing.

11. Line up the three screw holes and dowel pin hole on the clutch rotor with the screw holes and dowel pin on the drive shaft assembly hub. Place the clutch rotor onto the hub.
12. Using a 3/16” hex wrench, thread the three socket screws and lock washers through the clutch rotor and into the drive shaft assembly hub. Evenly snug, tighten, and torque the socket screws to 75–85 in.-lbs.
13. Make sure the friction surface of the clutch rotor is clean and free from oil or grease.
14. Follow steps 17–20 in the “Replacing the Gears” procedure to mate the pump housing with the gear housing.



Electrostatic discharge (ESD) potential could cause damage to electronic pressure control. Use Titan ESD wrist strap P/N 0507958 or equivalent when working on electronic pressure control.

15. Locate the two clutch field wires in the EPC housing. Gently pull the wires fully into the EPC housing so that there is no slack in the gear housing. Connect the wires to their proper terminals on the EPC board (refer to the labels created earlier in this procedure or the electrical schematic in the Parts List section of this manual).
16. Carefully place the EPC assembly over the EPC housing taking care not to pinch any wires.
17. Install the four screws that secure the EPC assembly to the EPC housing. Tighten securely.

Mating the Gear Housing and the Clutch Housing

1. Place the gear housing assembly onto the cart in front of the clutch housing. Line up the dowel pins in the gear housing with their corresponding holes in the clutch housing. Slide the gear housing assembly onto the clutch housing until there is no gap between the housings.
2. Thread the four hex screws and lock washers through the clutch housing and into the gear housing.
3. Using a 1/2" wrench, snug and tighten the hex screws in a crossing pattern. Torque to 140–155 in./lbs.
4. Using a 9/16" socket, thread the two hex screws that secure the gear housing to the cart through the underside of the cart and into the gear housing. Torque to 100–120 in./lbs.
5. Connect the wire from the EPC housing to its mating connector on the engine wire harness.
6. Make sure that there is a white PTFE o-ring on the end of the transducer that gets inserted into the filter housing. Insert the transducer into the filter housing port.
7. Hold the transducer tube with a pliers to prevent it from rotating, and turn the transducer nut clockwise with a 3/4" open-end wrench to tighten it into the filter housing. Torque the nut to 360–400 in./lbs.

Checking the Clutch Gap

1. Remove the plastic plug from the top of the clutch housing. Look through the port to locate the clutch armature and the clutch rotor.
2. Check the gap between the clutch armature and the clutch rotor using a .016" feeler gauge and a .035" feeler gauge.
 - a. Insert each feeler gauge through the port and into the gap between the clutch armature and the clutch rotor. The .016" feeler gauge should fit in the gap. The .035" feeler gauge should not fit in the gap.
 - b. Pull the engine pull cord several times to rotate the clutch armature, checking the gap with each feeler gauge between each pull.
 - c. If the .016" gauge does not fit or the .035" gauge does fit at any checkpoint, the gap must be readjusted. This is done by relocating the clutch hub and armature assembly on the engine shaft. Refer to the "Removing/Replacing the Clutch Hub and Armature Assembly" procedure.

Servicing the Fluid Section

Use the following procedures to service the valves and repack the fluid section.

1. Start the engine (refer to the procedures in the Operation section of this manual). Turn the pressure control knob clockwise to its maximum pressure setting.
2. Toggle the sprayer ON/OFF switch between the ON and OFF positions in short bursts until the slider assembly stops in a position where the fluid section connecting pin and retaining ring are visible through the slot in the slider housing.
3. Turn off the engine and perform the Pressure Relief Procedure.



Before proceeding, follow the Pressure Relief Procedure outlined previously in this manual. Additionally, follow all other warnings to reduce the risk of an injection injury, injury from moving parts or electric shock.

4. Loosen and remove the fluid hose from the fitting on the back of the cylinder of the fluid section.
5. Loosen and remove the four front cover screws. Remove the front cover.
6. Slide the retaining ring up on the slider assembly to expose the connecting pin.
7. Push the connecting pin forward through the slider assembly and piston. The connecting pin will fall out from the rear window of the slider housing where it can be retrieved.

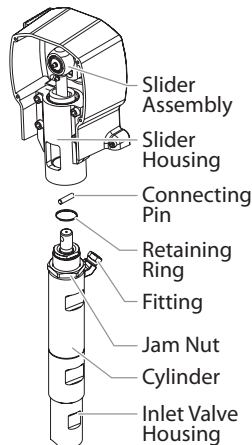

8. Using a wrench, turn the jam nut counterclockwise to loosen it from the pump housing.
9. Turn the fluid section counterclockwise to remove it from the pump housing.
10. Place the fluid section cylinder upright in a vise by clamping on the wrench flats.

NOTE: Do not over-tighten the vise. Damage to the cylinder may occur.

11. Loosen and remove the lower housing and inlet valve housing.
12. Remove the inlet cage, inlet valve ball, inlet valve seat, and o-ring from the inlet valve.
13. Clean out any debris in the inlet valve housing and examine the housing and the inlet valve seat. If the seat is damaged, reverse to the unused side or replace the seat. If necessary, remove and clean inlet screen. Use snap ring pliers to remove retaining ring.
14. Using a wrench, remove the upper seal retainer.
15. Slide the piston rod out through the bottom of the cylinder.
16. Inspect the piston rod for wear and replace if necessary.
17. Remove the adapter ring and upper packing assembly from the top of the cylinder.
18. Remove the lower packing assembly from the bottom of the cylinder.

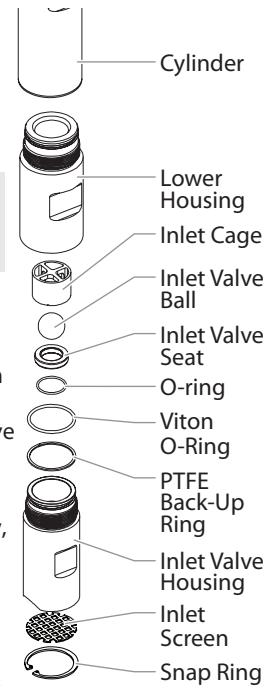

NOTE: Be careful not to scratch, score, or otherwise damage the cylinder during removal of the packing assemblies.

19. Remove the cylinder from the vise.
20. Insert the connection pin through the hole at the top of the piston rod and clamp each end of the connecting pin in the vise. This will hold the piston rod in position for disassembly.

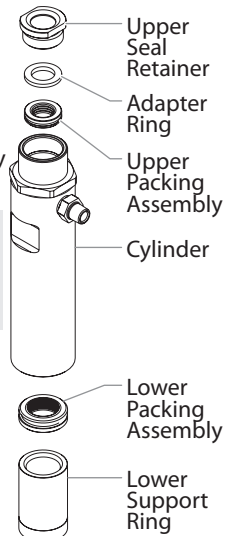

NOTE: Do not clamp the piston rod directly in the vise. Damage to the piston rod will occur.

21. Using a 3/8" hex wrench, loosen and remove the outlet valve retainer from the piston rod.
22. Remove the outlet valve seal, outlet cage, outlet valve ball, nylon washer, and outlet valve seat from the outlet valve retainer.
23. Clean out any debris and examine the retainer and outlet valve seat. If the seat is damaged, reverse to the unused side or replace the seat.
24. Clean and inspect the outlet cage and outlet valve ball. Replace if they are worn or damaged.
25. Reassemble the outlet valve assembly into the piston rod in the reverse order of how it was disassembled. Use the new parts supplied with the packing kit during reassembly. Apply blue Loctite #242 to the threads

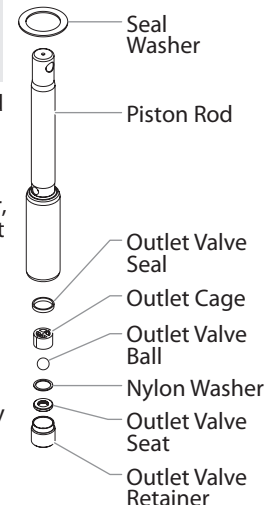

- of the outlet valve retainer. Torque the outlet valve retainer to 144 in.-lbs.
26. Remove the piston rod from the vise.
 27. Clean the cylinder. Inspect the cylinder for damage and replace if necessary.
 28. Place the cylinder upright in a vise by clamping on the wrench flats.
 29. Locate the new upper and lower packing assemblies and pack the areas between the packing lips with grease. Lubricate the o-rings on the exterior of the packings with grease.
 30. Insert the upper packing assembly into the top of the cylinder with the large beveled edge facing down.
 31. Insert the new adapter ring into the top of the cylinder with the small, center protrusion facing down. The adapter ring should rest on the upper packing assembly.
 32. Apply blue Loctite #242 to the threads of the upper seal retainer. Thread the upper seal retainer into the cylinder but do not tighten.
 33. Rotate the cylinder in the vise so that the bottom end is facing up.
 34. Pre-form the lower packing using the lower packing sizing tool (included in the repacking kit).
 35. Insert the lower packing assembly partially into the bottom of the cylinder with the large beveled edge facing toward the cylinder (beveled edge will be facing up when the cylinder is upright).
 36. Push the lower packing assembly into position using the lower packing insertion tool (see Fluid Section Assembly parts list for lower packing insertion tool P/N).
 37. Place the piston insertion tool (included in the repacking kit) over the top of the piston rod.
 38. Insert the piston rod into the bottom of the cylinder, through the lower packing assembly, through the upper packing assembly, and out through the upper seal retainer.
 39. Tighten the upper seal retainer. Torque to 450–480 in./lbs.

Install upper packing with large beveled edge facing down.

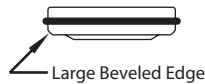

Large Beveled Edge



Install lower packing so large beveled edge will be facing up when the cylinder is upright.

NOTE: When repacking the fluid section, make sure the raised lip on the bottom of the lower packing assembly is fully outside the packing around the piston rod after insertion of the piston rod.

40. Apply blue Loctite to the bottom 3–4 threads on the cylinder. Turn the jam nut clockwise until it is flush against the top of the cylinder.
41. Lubricate the first several threads at the top of the cylinder with anti-seize compound. Remove the cylinder from vise.
42. Thread the cylinder into the pump housing, turning clockwise. When the connecting pin hole on the piston rod lines up with the hole in the slider assembly, insert the connecting pin.
43. Slide the retaining ring down on the slider assembly to cover the connecting pin.
44. Continue to turn the cylinder clockwise until the jam nut is flush against the pump housing.

NOTE: If the nipple on the cylinder does not face the back of the unit, turn the cylinder counterclockwise until the nipple faces the back of the unit. Do not turn the cylinder more than one full turn.

45. Once the nipple is positioned, turn the jam nut clockwise until it contacts the pump housing.
46. Tighten the jam nut with a wrench to tighten it against the pump housing. Torque to 960-1000 in./lbs.
47. Attach the high-pressure hose to the fitting on the back of the cylinder and tighten with a wrench. Do not kink the hose.

48. Install new PTFE o-ring onto lower housing. Thread lower housing into upper housing cylinder. Torque to 680-720 in.-lbs.
49. Making sure that the new Viton o-ring and new PTFE back-up ring are lubricated and in place, reassemble the inlet valve assembly and thread it into the cylinder. Use the new parts supplied with the packing kit during reassembly. Tighten the inlet valve housing until the o-ring engages, then continue to tighten until snug.
50. Using a wrench, hold the cylinder by the wrench flats and torque the inlet valve housing to 1020–1080 in.-lbs.
51. Place the front cover on the pump housing and secure in position using the four front cover screws.
52. Turn on the sprayer by following the procedure in the “Operation” section of this manual and check for leaks.

NOTE: Repacking kit P/N 055222 is available. For best results use all parts supplied in this kit.

Troubleshooting

Problem

Cause

Solution

A. The unit will not run.

1. The pressure is set too low.
2. Faulty or loose wiring.
3. The gas tank is empty.

1. Turn the pressure control knob clockwise to supply power to the unit and increase the pressure setting.
2. Inspect or take to a Titan authorized service center.
3. Fill the gas tank.

B. The unit will not prime.

1. The PRIME/SPRAY valve is in the SPRAY position.
2. Air leak in the siphon tube/siphon set.
3. The pump filter and/or inlet screen is clogged.
4. The siphon tube/siphon set is clogged.

1. Rotate the PRIME/SPRAY valve clockwise to the PRIME position.
2. Check the siphon tube/siphon set connection and tighten or re-tape the connection with PTFE tape.
3. Remove the pump filter element and clean. Remove the inlet screen and clean.
4. Remove the siphon tube/siphon set and clean.

C. The unit will not build or maintain pressure.

1. The spray tip is worn.
2. The spray tip is too large.
3. The pressure control knob is not set properly.
4. The pump filter, gun filter, or inlet screen is clogged.
5. Material flows from the return hose when the PRIME/SPRAY valve is in the SPRAY position.
6. Air leak in the siphon tube/siphon set.
7. There is external fluid leak.
8. There is an internal fluid section leak (packings are worn and/or dirty, valve balls are worn).
9. Worn valve seats

1. Replace the spray tip following the instructions that came with the spray gun.
2. Replace the spray tip with a tip that has a smaller orifice following the instructions that came with the spray gun.
3. Turn the pressure control knob clockwise to increase the pressure setting.
4. Remove the pump filter element and clean. Remove the gun filter and clean. Remove the inlet screen and clean.
5. Clean or replace the PRIME/SPRAY valve.
6. Check the siphon tube/siphon set connection and tighten or re-tape the connection with PTFE tape.
7. Check for external leaks at all connections. Tighten connections, if necessary.
8. Clean the valves and service the fluid section following the "Servicing the Fluid Section" procedure in the Maintenance section of this manual.
9. Reverse or replace the valve seats following the "Servicing the Fluid Section" procedure in the Maintenance section of this manual.

D. Fluid leakage at the upper end of the fluid section.

1. The upper packings are worn.
2. The piston rod is worn.

1. Repack the pump following the "Servicing the Fluid Section" procedure in the Maintenance section of this manual.
2. Replace the piston rod following the "Servicing the Fluid Section" procedure in the Maintenance section of this manual.

E. Excessive surge at the spray gun.

1. Wrong type of airless spray hose.
2. The spray tip worn or too large.
3. Excessive pressure.

1. Replace hose with a minimum of 50' of 3/8" grounded textile braid airless paint spray hose.
2. Replace the spray tip following the instructions that came with the spray gun.
3. Rotate the pressure control knob counterclockwise to decrease spray pressure.

F. Poor spray pattern.

1. The spray tip is too large for the material being used.
2. Incorrect pressure setting.
3. Insufficient fluid delivery.
4. The material being sprayed is too viscous.

1. Replace the spray tip with a new or smaller spray tip following the instructions that came with the spray gun.
2. Rotate the pressure control knob to adjust the pressure for a proper spray pattern.
3. Clean all screens and filters.
4. Add solvent to the material according to the manufacturer's recommendations.

G. The unit lacks power.

1. The pressure adjustment is too low.

1. Rotate the pressure control knob clockwise to increase the pressure setting.

Consignes de sécurité important



Lire toutes ces consignes avant d'utiliser l'appareil. Garder ces consignes.



Indique une situation à risque, laquelle, si elle n'est pas évitée, peut entraîner des blessures graves, voire la mort.

Pour réduire les risques d'incendie ou d'explosion, de choc électrique et de blessure, vous devez lire et comprendre les directives figurant dans ce manuel. Familiarisez-vous avec les commandes et l'utilisation adéquate de l'équipement.



MISE EN GARDE : EXPLOSION OU INCENDIE

Les vapeurs inflammables, telles que les vapeurs de solvant et de peinture, dans une zone de travail peuvent s'enflammer ou exploser.

MESURES PRÉVENTIVES :

1. Servez-vous de l'équipement dans un endroit bien aéré. Faites circuler beaucoup d'air frais dans l'endroit afin d'éviter l'accumulation de vapeurs inflammables dans la zone de pulvérisation. Entrez l'ensemble de la pompe dans un endroit bien aéré. Ne pulvérisez pas l'ensemble de la pompe.
2. Ne faites jamais le plein lorsque le moteur est en marche ou chaud. Éteignez le moteur et laissez-le refroidir. L'essence est inflammable. Elle peut s'enflammer ou exposer si on en renverse sur une surface chaude.
3. Éliminez toutes les sources d'inflammation, comme les veilleuses, les cigarettes, les lampes électriques portatives et les toiles de protection en plastique (risque d'arc statique).
4. Gardez la zone de travail exempte de débris, y compris des solvants, des chiffons et d'essence.
5. Ne branchez ou ne débranchez pas les cordons d'alimentation, ne mettez pas l'appareil en marche, n'allumez ou n'éteignez pas les lumières lorsque des vapeurs inflammables sont présentes.
6. Mettez à terre l'équipement et les objets conducteurs dans la zone de travail. Assurez-vous que le câble de mise à la terre relie la patte de mise à la terre à une prise de terre réelle.
7. Utilisez uniquement des tuyaux mis à la terre.
8. Tenez le pistolet de pulvérisation fermement contre le côté d'un seau mis à la terre lorsque vous pulvérisez dans le seau.
9. S'il y a production d'étincelles statiques ou si vous ressentez un choc, arrêtez le fonctionnement immédiatement.
10. Soyez au courant du contenu de la peinture et des solvants à pulvériser. Lisez toutes les fiches signalétiques (FS) et les étiquettes des récipients de peinture et de solvant. Suivez les consignes de sécurité du fabricant de peinture et du solvant.
11. N'utilisez pas de peinture ou de solvant contenant des hydrocarbures hydrogénés, comme du chlore, de l'eau de Javel, un agent anti-moisissure, du chlorure de méthylène et du trichloroéthane. Ils ne sont pas compatibles avec l'aluminium. Communiquez avec le fournisseur de revêtement au sujet de la compatibilité du produit avec l'aluminium.
12. Gardez un extincteur dans la zone de travail.



MISE EN GARDE : INJECTION CUTANÉE

Le jet de haute pression produit par cet appareil peut transpercer la peau et les tissus sous-jacents, causant des blessures graves pouvant entraîner l'amputation.

MESURES PRÉVENTIVES :

1. Ne dirigez pas le pistolet sur et ne pulvérisez pas les personnes ou les animaux.
2. N'approchez pas les mains ni d'autres parties du corps de la sortie du produit. Par exemple, ne tentez pas d'arrêter une fuite avec une partie du corps.
3. Utilisez toujours le protège-embout de la buse. Ne pulvérisez pas sans que le protège-embout de la buse ne soit installé.
4. Utilisez exclusivement un embout de buse spécifié par le fabricant.
5. Prenez garde quand vous nettoyez ou que vous changez les embouts de buse. Si l'embout se bouche pendant que vous pulvérisez, verrouillez TOUJOURS la détente du pistolet, arrêtez la pompe et libérez toute la pression avant de réparer ou de nettoyer l'embout ou le protecteur ou avant de changer d'embout. La pression n'est pas libérée par l'arrêt du moteur. La poignée du robinet-valve PRIME/SPRAY (AMORÇAGE/PULVÉRISATION) doit être placée sur PRIME pour libérer la pression. Consultez la PROCÉDURE DE LIBÉRATION DE PRESSION décrite dans le manuel de la pompe.
6. Ne laissez pas l'appareil sous tension ou sous pression quand vous vous en éloignez. Quand vous n'utilisez pas l'appareil, éteignez-le et libérez la pression conformément aux instructions du fabricant.
7. La pulvérisation à haute pression peut injecter des toxines dans le corps et causer de graves blessures corporelles. Si une telle injection se produisait, consultez immédiatement un médecin.
8. Vérifiez les tuyaux et les pièces pour détecter des signes d'endommagement : une fuite peut injecter le produit dans la peau. Inspectez le tuyau avant chaque emploi. Changez tous les tuyaux ou pièces endommagés.
9. Ce système peut produire une pression de 3300 PSI / 22.8 MPa. N'utilisez que les pièces de rechange ou les accessoires spécifiés par le fabricant et ayant une pression nominale minimum de 3300 PSI. Ceci est valable pour les embouts de pulvérisation, les protecteurs de buse, les pistolets, les rallonges, les raccords et le tuyau.
10. Verrouillez toujours la détente quand vous ne pulvérisez pas. Vérifiez que le verrou de la détente fonctionne correctement.
11. Vérifiez que toutes les connexions sont bien serrées avant d'utiliser l'appareil.
12. Sachez comment arrêter l'appareil et le dépressuriser rapidement. Soyez bien familiarisé avec les commandes. La pression n'est pas libérée lorsque le moteur est arrêté. La poignée du robinet-valve PRIME/SPRAY doit être placée sur PRIME pour libérer la pression. Consultez la PROCÉDURE DE LIBÉRATION DE PRESSION décrite dans le manuel de la pompe.
13. Retirez toujours l'embout de pulvérisation avant de rincer ou de nettoyer le système.

REMARQUE À L'INTENTION DES MÉDECINS : Les injections cutanées sont des lésions traumatiques; il importe donc de les traiter sans délai. On NE DOIT PAS retarder ce traitement sous prétexte de vérifier la toxicité du produit en cause, celle-ci n'étant conséquente que dans le cas d'injection directe de certains produits dans le système sanguin. Il pourrait s'avérer nécessaire de consulter un plasticien ou un spécialiste en chirurgie reconstructive de la main.

Consignes de sécurité important



MISE EN GARDE : GÉNÉRALITÉS

D'autres dangers peuvent entraîner des dommages matériels ou des blessures graves.

MESURES PRÉVENTIVES :

1. Portez toujours les gants, la protection oculaire, les vêtements et un respirateur ou masque appropriés quand vous peignez. Vapeurs dangereuses – Les peintures, solvants, insecticides et autres matières peuvent être dangereux s'ils sont inhalés ou entrent en contact avec le corps. Les vapeurs peuvent provoquer d'importantes nausées, une perte de connaissance ou un empoisonnement.
2. Ne travaillez pas et ne pulvérisez pas près d'enfants. Éloignez toujours les enfants de l'équipement.
3. Ne travaillez pas avec les bras au-dessus de la tête ni sur un support instable. Appuyez-vous bien sur les deux pieds pour toujours conserver l'équilibre.
4. Soyez attentif et regardez ce que vous faites.
5. N'utilisez pas l'appareil quand vous êtes fatigué ou sous l'influence de drogues ou d'alcool.
6. Ne faites pas de nœuds avec le tuyau et ne le tordez pas trop. Le tuyau à vide peut présenter des fuites suite à l'usure, les nœuds ou les mauvais traitements. Une fuite risque d'injecter du produit dans la peau.
7. N'exposez pas le tuyau à des températures ou des pressions supérieures à celles spécifiées par le fabricant.
8. N'utilisez pas le tuyau pour tirer ou soulever l'équipement.
9. Utilisez la plus basse pression possible pour rincer l'équipement.
10. Respectez tous les codes locaux, étatiques et nationaux qui régulent la ventilation, la prévention d'incendies et le fonctionnement.
11. Les normes de sécurité du gouvernement des États-Unis ont été adoptées dans la loi Occupational safety and Health Act (OSHA). Ces normes, en particulier la partie 1910 des Normes générales et la partie 1926 des Normes de construction, doivent être consultées.
12. Avant chaque emploi, vérifiez tous les tuyaux pour détecter d'éventuelles coupures, fuites, abrasion ou couvercle bombé. Vérifiez l'état ou le mouvement des accouplements. Changez immédiatement le tuyau si l'une de ces conditions est vérifiée. Ne réparez jamais un tuyau de peinture. Remplacez-le par un tuyau conducteur à haute pression.
13. Ne pulvérisez pas à l'extérieur par temps venteux.
14. Débranchez toujours le cordon électrique de la prise avant de travailler sur l'équipement.

IMPORTANT: Ne pas soulever par la poignée du chariot lors du chargement ou du déchargement.

Sécurité des moteurs à essence



Les produits chimiques contenus dans les vapeurs d'échappement de cet appareil sont reconnus par l'État de la Californie (États-Unis) comme étant cancérigènes. Ils peuvent également entraîner des anomalies congénitales ou d'autres dangers pour la santé.

- Les moteurs sont conçus pour fonctionner en toute sécurité et avec une fiabilité maximale s'ils sont utilisés conformément aux instructions. Veuillez lire et comprendre le manuel de l'utilisateur de Honda avant de faire fonctionner le moteur. Le non-respect de ces consignes peut entraîner des dommages matériels ou des blessures physiques graves.
- Pour éviter tout risque d'incendie et fournir une ventilation adéquate, placez le moteur à une distance minimale de 1 mètre (3 pieds) des immeubles et d'autres équipements pendant son fonctionnement. Ne placez pas d'objets inflammables à côté du moteur.
- Tenez les enfants et les animaux domestiques à l'écart de la zone de travail; vous éviterez ainsi tout risque de brûlures sur les pièces chaudes du moteur et de blessures entraînées par les accessoires utilisés par le moteur pour son fonctionnement.
- Sachez comment arrêter rapidement le moteur, et assurez-vous que vous avez bien compris le fonctionnement de toutes les commandes. Ne permettez jamais à une personne de faire fonctionner le moteur sans connaître les instructions nécessaires.
- L'essence est extrêmement inflammable et explosive dans certaines conditions.
- Remplissez le réservoir de carburant dans une zone bien ventilée, moteur arrêté. Ne fumez pas et évitez toutes flammes ou étincelles dans la zone de remplissage de carburant ou dans une zone de stockage du carburant.
- Veillez à ne pas faire déborder le réservoir de carburant. Après remplissage, assurez-vous que le bouchon du réservoir est solidement vissé.
- Faites attention à ne pas renverser de carburant lors du remplissage du réservoir. Les vapeurs ou les éclaboussures de carburant peuvent s'enflammer. En cas d'éclaboussures, assurez-vous que la zone est bien sèche avant de faire démarrer le moteur.
- Ne faites jamais fonctionner le moteur dans un endroit fermé ou confiné. Les fumées d'échappement contiennent du monoxyde de carbone qui est un gaz toxique; une exposition prolongée peut entraîner une perte de conscience et peut s'avérer mortelle.
- Le silencieux devient très chaud pendant le fonctionnement et reste chaud quelque temps après l'arrêt du moteur. Faites attention à ne pas toucher le silencieux tant qu'il est chaud. Pour éviter des brûlures graves ou des risques d'incendie, laissez le moteur refroidir avant de le transporter ou de le ranger à l'intérieur.
- Ne transportez jamais le moteur si le réservoir est plein.

Información de seguridad importante



Lea toda la información de seguridad antes de operar el equipo. Guarde estas instrucciones.



Indica una situación peligrosa que, de no evitarse, puede causar la muerte o lesiones graves.

Para reducir los riesgos de incendios, explosiones, descargas eléctricas o lesiones a las personas, lea y entienda todas las instrucciones incluidas en este manual. Familiarícese con los controles y el uso adecuado del equipo.



ADVERTENCIA: EXPLOSIÓN O INCENDIO

Los vapores inflamables, como los vapores de las pinturas y los solventes, pueden encenderse o explotar en el área de trabajo.

PREVENCIÓN:

1. Use el equipo solo en áreas bien ventiladas. Mantenga un buen suministro de aire fresco moviéndose a través del área para mantener el aire al interior del área de pulverización libre de acumulación de vapores inflamables. Mantenga el conjunto de la bomba en un área bien ventilada. No pulverice el conjunto de la bomba.
2. No llene el tanque de combustible mientras el motor esté en marcha o está caliente; apague el motor y deje que se enfríe. El combustible es inflamable y puede encenderse o explotar si se derrama sobre una superficie caliente.
3. Elimine todas las fuentes de encendido como luces de piloto, cigarrillos, lámparas eléctricas portátiles y cubiertas plásticas (potenciales arcos estáticos).
4. Mantenga el área de trabajo libre de desechos, lo que incluye solventes, trapos y gasolina.
5. No conecte o desconecte cables de alimentación ni prenda o apague interruptores de luz o de energía cuando hay vapores inflamables presentes.
6. Conecte a tierra el equipo y los objetos conductores en el área de trabajo. Asegúrese de que el cable de conexión a tierra (no viene equipado) está conectado desde el terminal de conexión a tierra a tierra verdadera.
7. Use solo mangueras conectadas a tierra.
8. Sostenga firmemente la pistola pulverizadora en el costado de un cubo conectado a tierra cuando se aprieta el gatillo hacia un cubo.
9. Si hay formación estática de chispas o si usted siente una descarga, detenga inmediatamente la operación.
10. Conozca el contenido de la pintura y de los solventes que se pulverizan. Lea todas las hojas de datos de seguridad de materiales (MSDS) y las etiquetas de los recipientes proporcionadas con las pinturas y solventes. Siga las instrucciones de seguridad de los fabricantes de las pinturas y los solventes.
11. No use una pintura o un solvente que contenga hidrocarburos halogenados. Tales como: cloro, fungicida, blanqueador, cloruro de metileno y tricloroetano. Estos no son compatibles con el aluminio. Contacte con el proveedor del recubrimiento para obtener información acerca de la compatibilidad del material con el aluminio.
12. Mantenga un extintor de incendios en el área.



ADVERTENCIA: LESIÓN POR INYECCIÓN

El flujo de pintura a alta presión que produce este equipo puede perforar la piel y los tejidos subyacentes, ocasionando lesiones graves y posible amputación. CONSULTE A UN MÉDICO INMEDIATAMENTE.

PREVENCIÓN:

1. No apunte con la pistola ni pulverice sobre ninguna persona ni animal.
2. Mantenga las manos y el resto del cuerpo lejos de la descarga. Por ejemplo, no trate de detener fugas con ninguna parte de su cuerpo.
3. Utilice siempre el protector de la boquilla. No pulverice sin el protector en su sitio.
4. Utilice solamente la boquilla especificada por el fabricante.
5. Tenga cuidado al limpiar y cambiar las boquillas. Si la boquilla se atasca durante la pulverización, ponga SIEMPRE el seguro del gatillo de la pistola, apague la bomba y libere toda la presión antes de reparar, limpiar el protector o la boquilla o cambiar la boquilla. La presión no se libera apagando el motor. Para liberar la presión hay que poner la manija de la válvula PRIME/SPRAY (cebar/pulverizar) en PRIME. Consulte el Procedimiento para liberar presión que se describe en el manual de la bomba.
6. No deje el aparato con corriente ni con presión cuando nadie esté pendiente de ella. Cuando no utilice el aparato, apáguelo y libere la presión siguiendo las instrucciones del fabricante.
7. La pulverización a alta presión puede inyectar toxinas en el cuerpo y producir daños graves en el mismo. En caso de que esto ocurra, visite a un médico inmediatamente.
8. Compruebe las mangueras y las piezas en busca de daños; una fuga puede inyectar material en la piel. Inspeccione la manguera antes de cada uso. Sustituya las mangueras o las piezas dañadas.
9. Este sistema es capaz de producir 3300 PSI / 22.8 MPa. Utilice solamente piezas de repuesto o accesorios especificados por el fabricante y con una capacidad nominal de 3300 PSI como mínimo. Entre ellos se incluyen boquillas pulverizadoras, protectores para las boquillas, pistolas, alargadores, racores y mangueras.
10. Ponga siempre el seguro del gatillo cuando no esté pulverizando. Verifique que el seguro del gatillo funciona correctamente.
11. Antes de utilizar el aparato, verifique que todas las conexiones son seguras.
12. Aprenda a detener el aparato y a liberar la presión rápidamente. Familiarícese a conciencia con los controles. La presión no se libera apagando el motor. Para liberar la presión hay que poner la manija de la válvula PRIME/SPRAY (cebar/pulverizar) en PRIME. Consulte el Procedimiento para liberar presión que se describe en el manual de la bomba.
13. Quite siempre la boquilla pulverizadora antes de enjuagar o limpiar el sistema.

NOTA PARA EL MÉDICO: La inyección a través de la piel es una lesión traumática. Es importante tratar la lesión tan pronto sea posible. NO retrase el tratamiento para investigar la toxicidad. La toxicidad es un factor a considerar con ciertos revestimientos inyectados directamente en la corriente sanguínea. Puede ser aconsejable consultar con un cirujano plástico o un cirujano especialista en reconstrucción de las manos.

Información de seguridad importante



ADVERTENCIA: GENERAL

Puede causar daños materiales o lesiones graves.

PREVENCIÓN:

1. Cuando pinte, lleve siempre guantes, protección para los ojos, ropa y un respirador o máscara adecuados. Vapores peligrosos: Las pinturas, disolventes, insecticidas y otros materiales pueden ser perjudiciales si se inhalan o entran en contacto con el cuerpo. Los vapores pueden producir náuseas intensas, desmayos o envenenamiento.
2. Nunca utilice el aparato ni pulverice cerca de niños. Mantenga el equipo alejado de los niños en todo momento.
3. No se estire demasiado ni se apoye sobre un soporte inestable. Mantenga los pies bien apoyados y el equilibrio en todo momento.
4. No se distraiga y tenga cuidado con lo que hace.
5. No utilice el aparato si está fatigado o se encuentra bajo la influencia del alcohol o de las drogas.
6. No retuerza ni doble la manguera en exceso. En la manguera airless pueden aparecer fugas a causa del desgaste, de retorcimientos o de un mal uso. Una fuga puede inyectar material en la piel.
7. No exponga la manguera a temperaturas o presiones que superen las especificadas por el fabricante.
8. No utilice la manguera como elemento de fuerza para tirar del equipo o levantarlo.
9. Utilice la presión más baja posible para enjuagar el equipo.
10. Cumpla todos los reglamentos locales, estatales y nacionales pertinentes relativos a ventilación, prevención de incendios y funcionamiento.
11. Las normas sobre seguridad del gobierno de los Estados Unidos se han adoptado al amparo de la Ley de salud y seguridad ocupacional (OSHA). Deben consultarse tres normas, particularmente la sección 1910 de las Normas generales y la sección 1926 de las Normas sobre construcción.
12. Cada vez que vaya a utilizar el equipo, compruebe antes todas las mangueras en busca de cortes, fugas, abrasión o bultos en la cubierta. Compruebe el movimiento de los acoplamientos y si están dañados. Sustituya inmediatamente una manguera si descubre alguna de estas anomalías. No repare nunca una manguera de pintura. Sustitúyala por una manguera conductora a alta presión.
13. No pulverice al aire libre si hace viento.
14. Desenchufe siempre el cable antes de trabajar en el equipo.

IMPORTANTE: No cargue el equipo por el asa del carrito durante la carga y descarga.

Seguridad con los motores de gasolina



El escape del motor de esta unidad contiene químicos que el Estado de California ha determinado causan cáncer, defectos de nacimiento u otros daños al sistema reproductor.

1. Los motores están diseñados para proporcionar un servicio seguro y fiable, si se utilizan de acuerdo a las instrucciones. Lea y entienda las instrucciones del Manual del Propietario de Robin-Subaru antes de utilizar el motor. De lo contrario, podría causar lesiones personales o daño al equipo.
2. Para evitar peligros de incendio y para proporcionar una ventilación adecuada, mantenga el motor por lo menos a 1 metro de los edificios y de otro equipo durante su uso. No coloque objetos inflamables cerca del motor.
3. Mantenga a los niños y las mascotas alejados de la zona de trabajo, pues existe la posibilidad de quemaduras causadas por los componentes calientes del motor o lesiones causadas por cualquier equipo en el que se utilice el motor.
4. Sepa cómo apagar el motor rápidamente y comprenda el funcionamiento de todos los controles. Nunca permita a nadie operar el motor sin las instrucciones apropiadas.
5. La gasolina es extremadamente inflamable y es explosiva bajo ciertas condiciones.
6. Llene el tanque de combustible en un lugar bien ventilado y con el motor apagado. No fume ni permita que haya llamas ni chispas en la zona de llenado ni en donde se almacena el combustible.
7. No llene en exceso el tanque de combustible. Después de ponerle combustible, asegúrese de que la tapa del tanque esté cerrada completamente.
8. Tenga cuidado de no derramar el combustible. Los gases del combustible o el combustible derramado pueden encenderse. Si se derrama combustible, asegúrese de que la zona esté seca antes de encender el motor.
9. Nunca utilice el motor en un lugar encerrado o confinado. El escape contiene gas de monóxido de carbono venenoso; la exposición a este gas puede causar pérdida del conocimiento y puede conducir a la muerte.
10. El escape se calienta mucho durante su uso y permanece caliente durante un rato después de apagar el motor. Asegúrese de no tocar el escape cuando esté caliente. Para evitar quemaduras graves o peligros de incendio, deje que el motor se enfríe antes de transportarlo o guardarlo bajo techo.
11. Nunca envíe ni transporte la unidad con gasolina en el tanque.

Parts List

Main Assembly

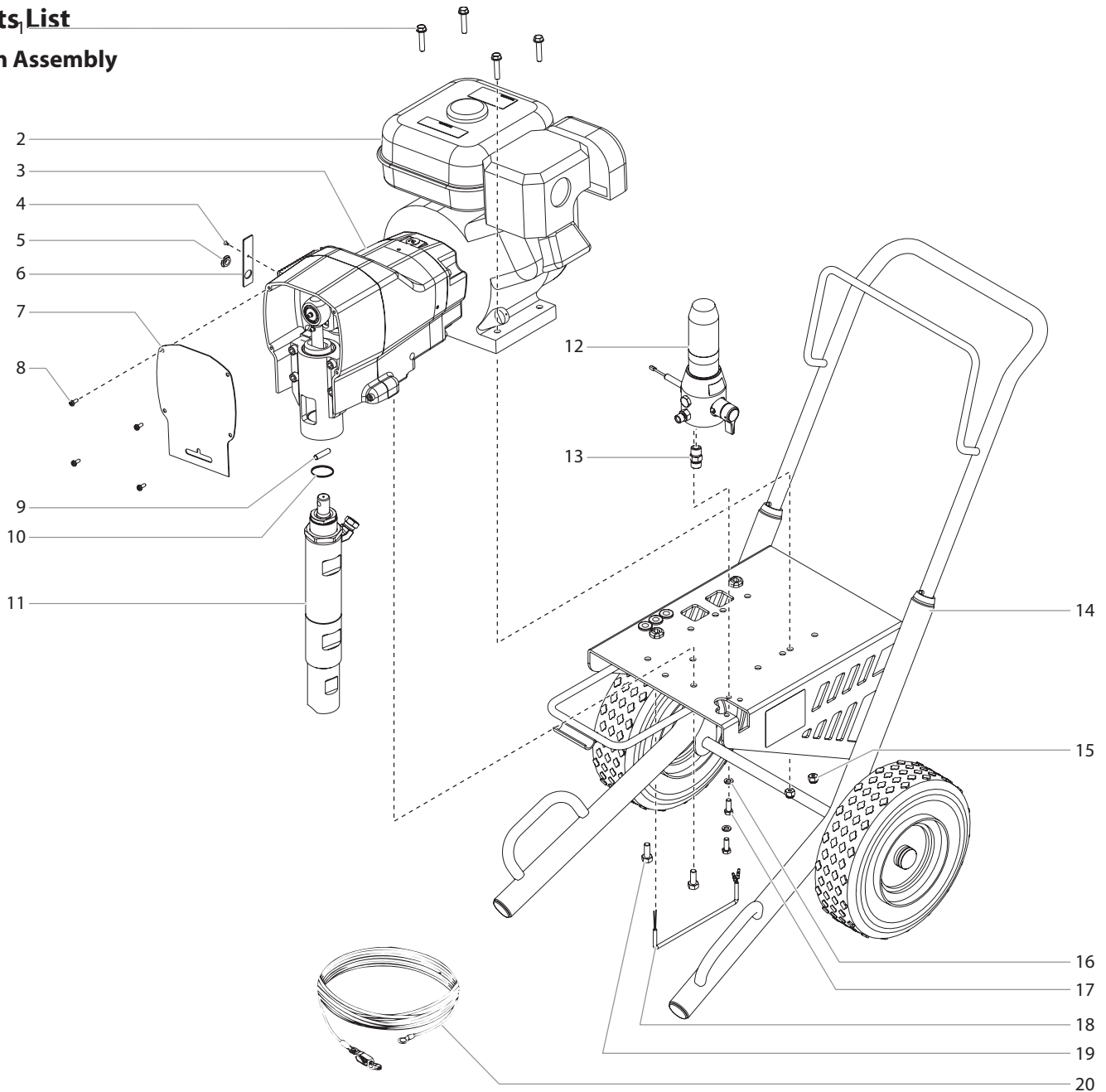

Item	Part No.	Description	Qty.
1	0509550	Hex screw	4
2	-----	Engine	1
3	-----	Drive assembly	1
4	704-282	Screw	1
5	704-281	Port plug	1
6	0509627	Controller cover	1
7	0555216	Front cover with label	1
8	0509552	Screw	4
9	0509520	Connecting pin	1
10	0509521	Retaining ring	1
11	0555265A	Fluid section assembly	1

Item	Part No.	Description	Qty.
12	0558741A	Filter assembly	1
13	0508343	Fitting, 3/8"	1
14	-----	Cart assembly	1
15	763-549	Lock nut	4
16	0507786	Lock washer	2
17	0507787	Hex screw	2
18	0555201	Wire harness	1
19	0509553	Screw	2
20	730-165	Grounding cable	1
21	0507785	Return hose (not shown)	1
22	0507404	Hose, high pressure (not shown)	1

Drive Assembly

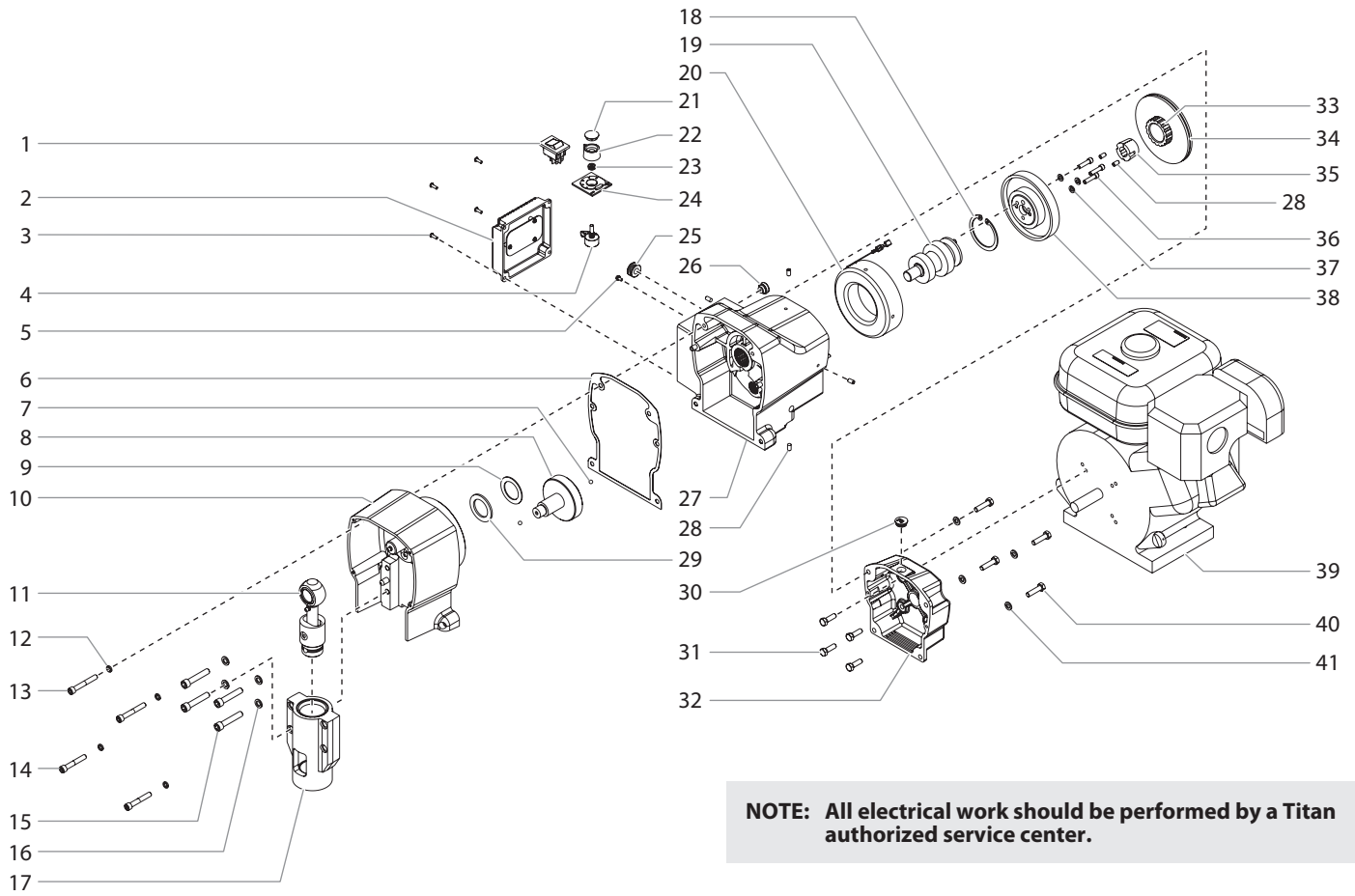

NOTE: All electrical work should be performed by a Titan authorized service center.

Item	Part No.	Description	Qty.
1	9850936	ON/OFF switch	1
2	0290924	Electronic pressure control assembly	1
3	700-139	Screw	4
4	0507973	Potentiometer	1
5	9800340	Ground screw	1
6	0509495	Gasket	1
7	0509562	Ball	2
8	0509564	Gear assembly	1
9	0509559	Thrust washer	1
10	0555245	Pump housing	1
11	0555230A	Slider assembly	1
12	0509541	Washer	4
13	0509539	Socket screw, 2.25"	2
14	0509540	Socket screw, 2"	2
15	0509561	Socket screw	4
16	761-257	Lock washer	4
17	0555249A	Slider housing	1
18	0509565	Retaining ring	1
19	0509567	Drive shaft assembly	1
20	0555902	Clutch field assembly	1
21	0507748	Cap	1

Item	Part No.	Description	Qty.
22	0507740	Pressure control knob	1
23	0507749	Seal nut	1
24	0509557	Mounting plate	1
25	0507784	Grommet, 7/16"	1
26	0509531	Grommet, liquid tight	1
27	0555189A	Gear housing	1
28	0509573	Set screw	6
29	0509563	Thrust bearing	1
30	0509574	Plug	1
31	0509538	Screw	4
32	0555633A	Clutch housing	1
33	763-520	Clutch hub	1
34	0509570	Clutch hub and armature (includes items 28(2), 33, and 35)	1
35	763-550	Taper lock bushing (includes item 28(2))	1
36	0509566	Socket screw	3
37	9821503	Lock washer	3
38	0509568	Clutch rotor	1
39	0555621	Engine	1
40	0509569	Hex screw	4
41	0507786	Lock washer	4

Fluid Section Assembly (P/N 0555265A)

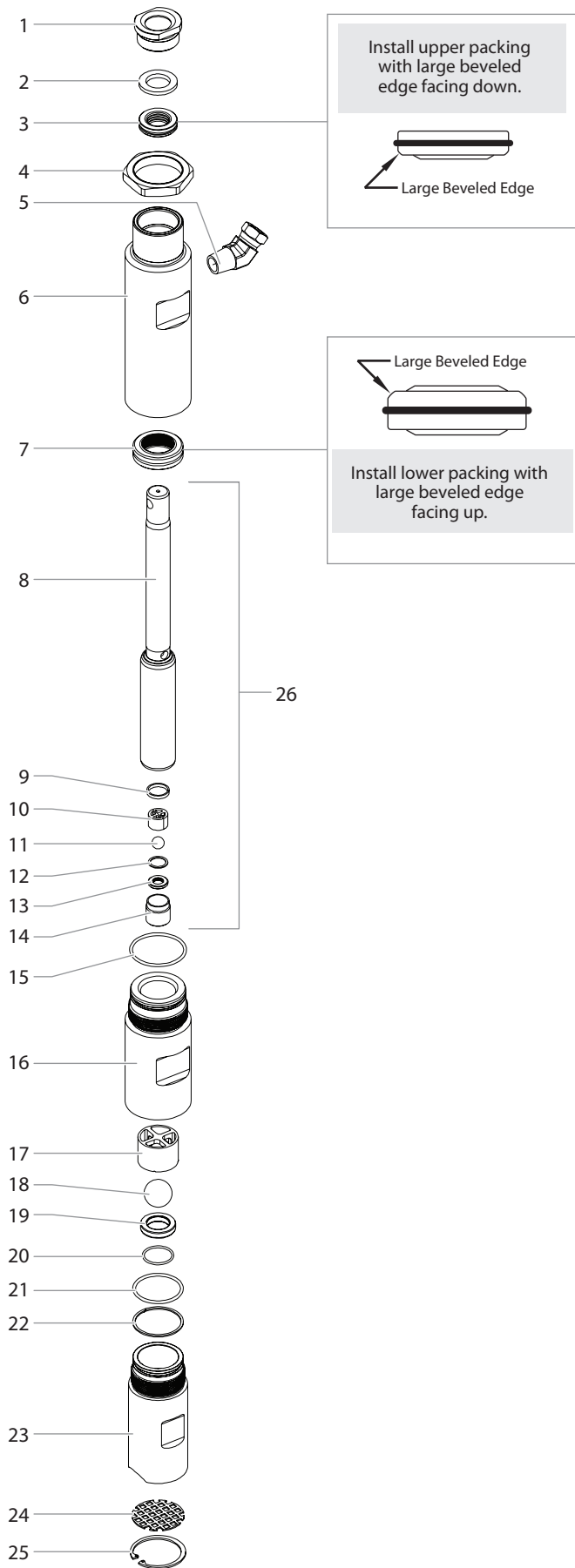

Item	Part No.	Description	Qty.
1	0509536	Upper seal retainer	1
2	0509430	Adapter ring	1
3	0509935	Upper packing assembly	1
4	0509505	Jam nut	1
5	0507403	Fitting	1
6	0555906	Upper housing cylinder	1
7	0509936	Lower packing assembly	1
8	0555909	Piston	1
9	0509648	Outlet valve seal	1
10	0509601	Outlet cage	1
11	0509710	Outlet valve ball	1
12	0507454	Nylon washer	1
13	0509655	Outlet valve seat	1
14	0507733	Outlet valve retainer	1
15	173-133	Lower housing o-ring	1
16	0555907	Lower housing	1
17	0509602	Inlet cage	1
18	0509707	Inlet valve ball	1
19	0509623	Inlet valve seat	1
20	0509708	O-ring, PTFE	1
21	0509652	Viton o-ring	1
22	0509653	Back-up ring, PTFE	1
23	0555903	Inlet valve	1
24	0555217	Inlet screen	1
25	431-054	Snap ring	1
26	0555783	Piston assembly (includes items 8-14)	1
	0555222	Repacking kit (includes items 2, 3, 7, 9, 11, 12, 18, and 20-22)	
	0509934	Lower packing insertion tool	

NOTE: When repacking the fluid section, make sure the raised lip on the bottom of the lower packing is fully outside the packing around the piston rod after insertion of the piston rod.

Cart Assembly

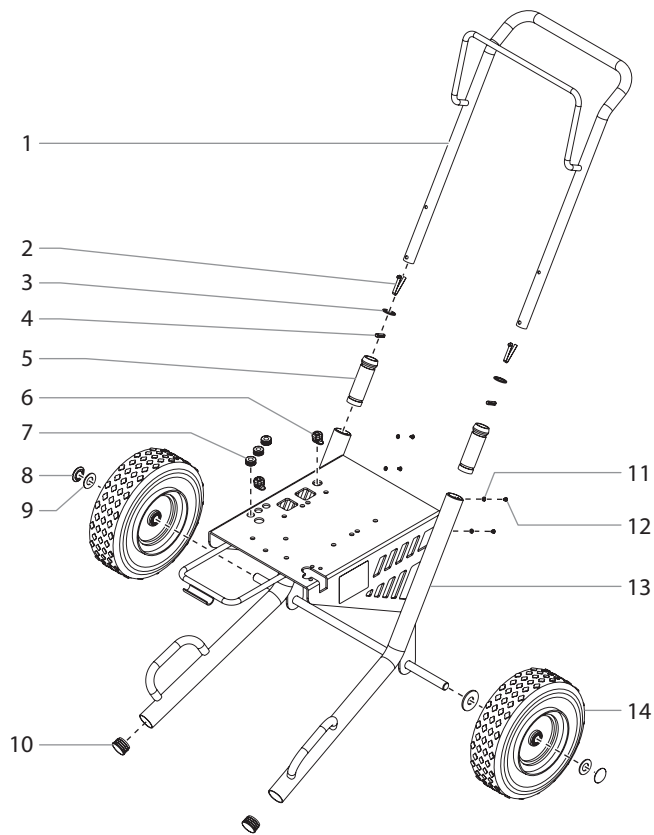

Item	Part No.	Description	Qty.
1	0507766	Handle (includes items 2-5, 11, and 12)	1
2	9841504	Snap button	2
3	0295609	Handle washer	2
4	0295610	Roll pin	2
5	0295607	Handle sleeve	2
6	0555603	Strain relief	2
7	0507784	Grommet	3
8	0509625	Axle cap	2
9	0509626	Wheel spacer	2
10	9885571	Plug	2
11	0509386	Lock washer	4
12	0295608	Screw	4
13	0555218	Cart (includes item 10)	1
14	0509624	Wheel	2

Filter Assembly

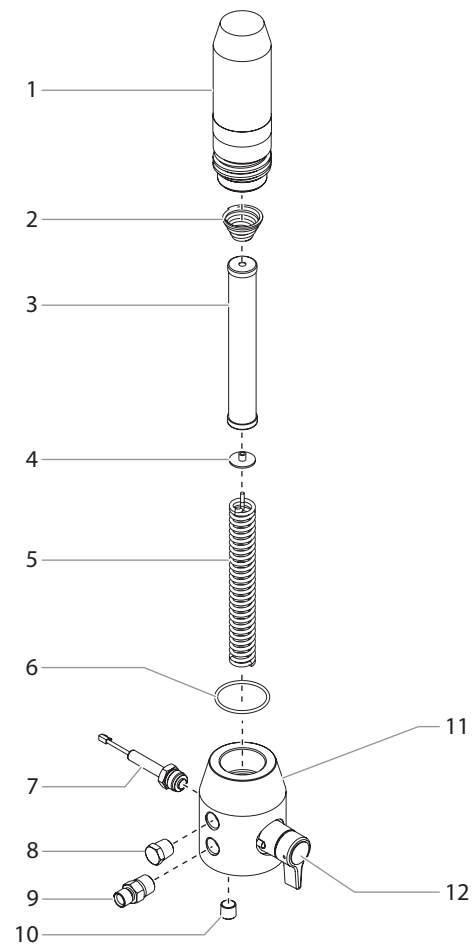

Item	Part No.	Description	Qty.
1	0508723	Filter body	1
2	0508602	Filter spring	1
3	0508748	Filter, 60 mesh (standard)	1
	0508451	Filter, 30 mesh (optional)	
	0508452	Filter, 100 mesh (optional)	
4	0508603	Adapter	1
5	0508749	Filter support spring	1
6	800-906	O-ring, PTFE	1
7	0507737	Transducer	1
8	0509420	Plug, 3/8"	1
9	0508343	Outlet fitting, 3/8" x 1/4"	1
	812-003	Outlet fitting, 3/8" x 1/4" (optional)	
10	0295697	Plug, 1/4"	1
11	0555625	Filter housing	1
12	0507690	PRIME/SPRAY valve assembly	1

PRIME/SPRAY Valve Assembly

(P/N 0507690)

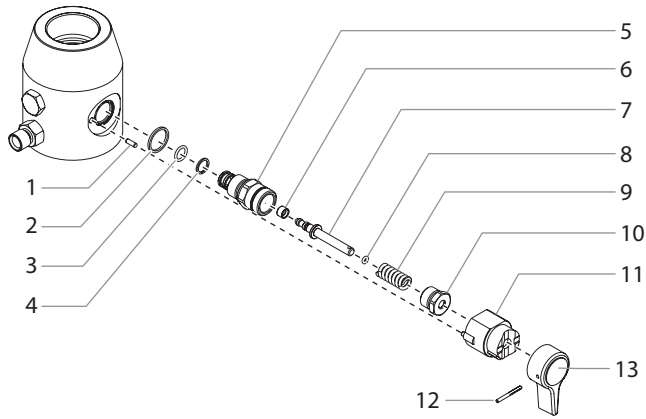

Item	Part No.	Description	Qty.
1	0507736	Dowel pin	1
2	0507745	Gasket	1
3	5000529	O-ring, PTFE	1
4	221-012	O-ring, Viton	1
5	0507744	Valve housing	1
6	0507746	Valve seat	1
7	0507743	Valve stem	1
8	5006547	O-ring, Viton	1
9	0507747	Spring	1
10	0507742	Valve retainer	1
11	0507735	Cam base	1
12	5006543	Groove pin	1
13	0507662	Valve handle	1

Electrical Schematic

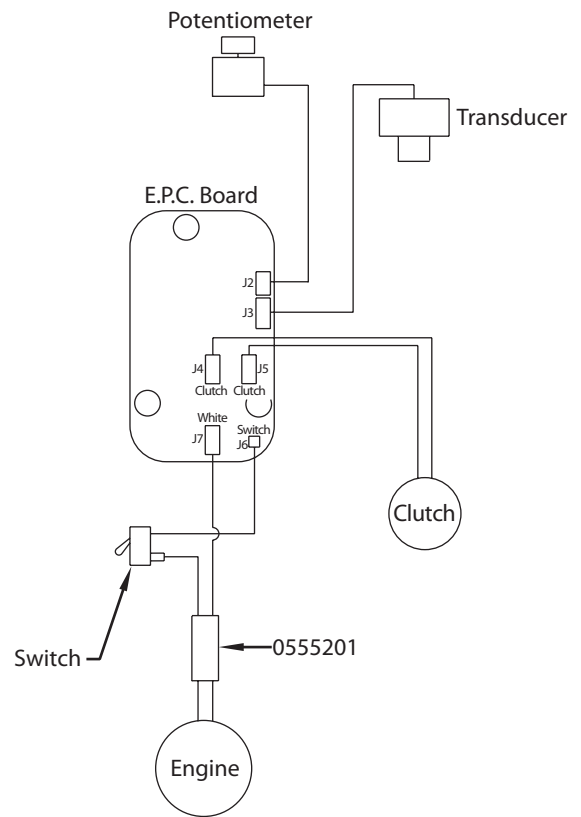

Labels

Part #	Description
0290803	Front cover label
0295840	Warning label, explosion
0295841	Warning label, injection
0295805	Shock hazard label
0509819	"No Oil" label

Accessories

Part No.	Description
661-xxx	Tip Assembly
661-012	Tip Guard (7/8")
550-227	Hose, Whip End, 6' x 1/4"
316-513	Hose, Wireless, 25' x 1/4"
316-505	Hose, Wireless, 50' x 1/4"
0093896	Hose Connector, 1/4" x 1/4"M
0088154	Pressure Gauge, 0-5000 PSI
311-050-9	9" Roller Cover, 1/2" Nap
311-075-9	9" Roller Cover, 3/4" Nap
311-125-9	9" Roller Cover, 1-1/4" Nap
0152235	12" Roller Cover, 1/2" Nap
312-075-12	12" Roller Cover, 3/4" Nap
0152238	12" Roller Cover, 1-1/4" Nap
0093930	Anti-Seize Compound
0296329	G-10 XL Four Finger Airless Spray Gun (no tip)
0296235	G-10 XL Four Finger Airless Spray Gun with 517 reversible tip
0296260	G-10 XL Two Finger Airless Spray Gun (no tip)
0296236	G-10 XL Two Finger Airless Spray Gun with 517 reversible tip
0296326	G-10 XL Four Finger Spray Pack with 50' x 1/4" airless hose
0296327	G-10 XL Two Finger Spray Pack with 50" x 1/4" airless hose
550-100	Airless Spray Gun with 517 reversible tip
550-110	S-5 Spray Pack with 50' x 1/4" airless hose
0507958	Electrostatic discharge (ESD) wrist strap
9870307	Grease, 6 lb. can

Warranty

Titan Tool, Inc., ("Titan") warrants that at the time of delivery to the original purchaser for use ("End User"), the equipment covered by this warranty is free from defects in material and workmanship. With the exception of any special, limited, or extended warranty published by Titan, Titan's obligation under this warranty is limited to replacing or repairing without charge those parts which, to Titan's reasonable satisfaction, are shown to be defective within twelve (12) months after sale to the End User. This warranty applies only when the unit is installed and operated in accordance with the recommendations and instructions of Titan.

This warranty does not apply in the case of damage or wear caused by abrasion, corrosion or misuse, negligence, accident, faulty installation, substitution of non-Titan component parts, or tampering with the unit in a manner to impair normal operation.

Defective parts are to be returned to an authorized Titan sales/service outlet. All transportation charges, including return to the factory, if necessary, are to be borne and prepaid by the End User. Repaired or replaced equipment will be returned to the End User transportation prepaid.

THERE IS NO OTHER EXPRESS WARRANTY. TITAN HEREBY DISCLAIMS ANY AND ALL IMPLIED WARRANTIES INCLUDING, BUT NOT LIMITED TO, THOSE OF MERCHANTABILITY AND FITNESS FOR A PARTICULAR PURPOSE, TO THE EXTENT PERMITTED BY LAW. THE DURATION OF ANY IMPLIED WARRANTIES WHICH CANNOT BE DISCLAIMED IS LIMITED TO THE TIME PERIOD SPECIFIED IN THE EXPRESS WARRANTY. IN NO CASE SHALL TITAN LIABILITY EXCEED THE AMOUNT OF THE PURCHASE PRICE. LIABILITY FOR CONSEQUENTIAL, INCIDENTAL OR SPECIAL DAMAGES UNDER ANY AND ALL WARRANTIES IS EXCLUDED TO THE EXTENT PERMITTED BY LAW.

TITAN MAKES NO WARRANTY AND DISCLAIMS ALL IMPLIED WARRANTIES OF MERCHANTABILITY AND FITNESS FOR A PARTICULAR PURPOSE WITH RESPECT TO ACCESSORIES, EQUIPMENT, MATERIALS OR COMPONENTS SOLD BUT NOT MANUFACTURED BY TITAN. THOSE ITEMS SOLD, BUT NOT MANUFACTURED BY TITAN (SUCH AS GAS ENGINES, SWITCHES, HOSES, ETC.) ARE SUBJECT TO THE WARRANTY, IF ANY, OF THEIR MANUFACTURER. TITAN WILL PROVIDE THE PURCHASER WITH REASONABLE ASSISTANCE IN MAKING ANY CLAIM FOR BREACH OF THESE WARRANTIES.

Material Safety Data Sheets (MSDS) are available on Titan's website or by calling Customer Service.

The logo for Titan Tool, Inc. features the word "TITAN" in a bold, italicized, sans-serif font. The letters are black with a white outline, and a small trademark symbol (TM) is located to the upper right of the letter "N".

United States Sales & Service

Phone: 1-800-526-5362

Fax: 1-800-528-4826

1770 Fernbrook Lane
Plymouth, MN 55447
www.titantool.com

International Sales

international@titantool.com

Fax: 1-763-519-3509

1770 Fernbrook Lane
Plymouth, MN 55447