



Advanced Performance. Total Reliability.

ADVANTAGE™ Series



Owner's Manual

Read this manual for complete instructions

Français (page 25) / Español (página 49)

Contents

- 2 Important Safety Information
- 4 What's in the Box?
- 5 Proper Use and Functions
- 6 Assembly
- 7 Pressure Relief Procedure
- 8 Load Material
- 9 Getting Material to Flow
- 10 Practice Spraying
- 12 Clear the Spray Tip
- 13 Clean the Spray Gun Filter
- 14 Clean the Inlet Filter
- 15 Short Term Storage
- 16 Cleanup - latex materials
- 18 Cleanup - oil-based materials
- 19 Cleaning the Spray Gun Components
- 20 Long-Term Storage
- 21 Cleaning the Sureflo™ Valve
- 22 Troubleshooting
- 72 Parts List
- 76 Warranty

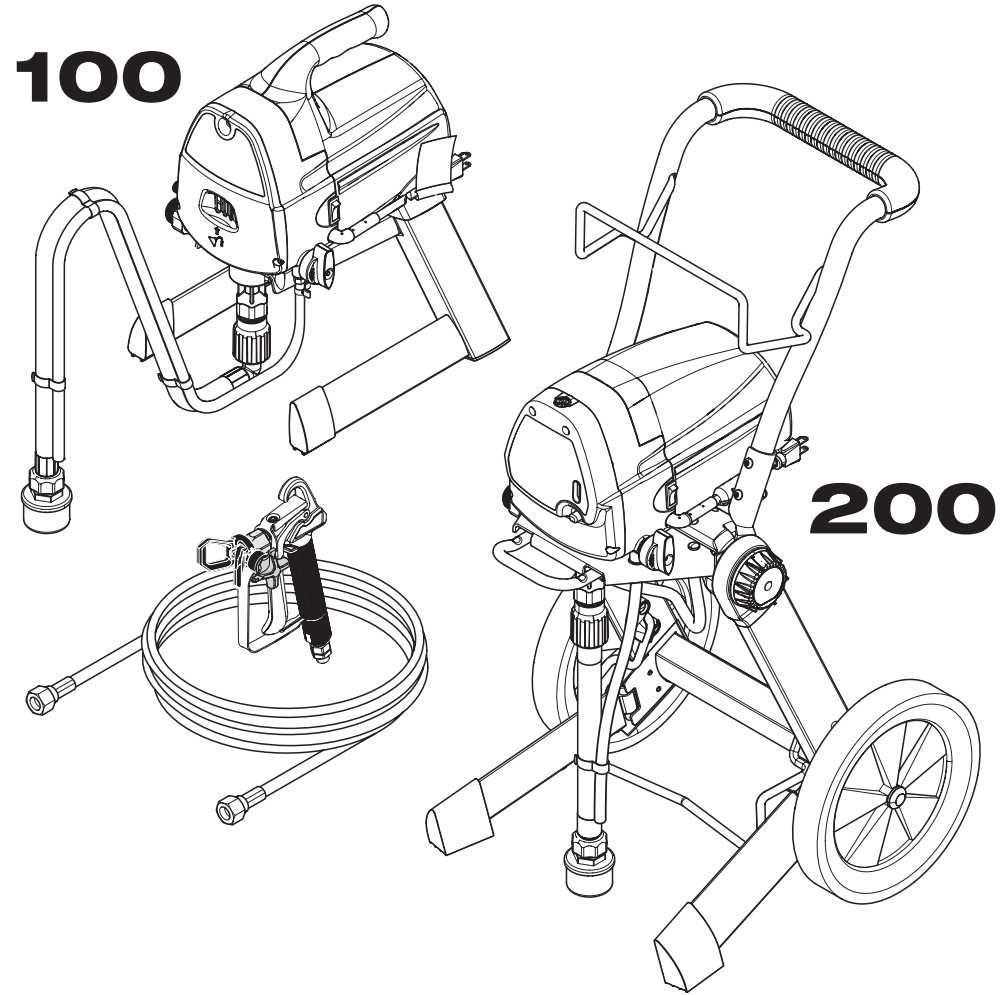

Questions?

Call Titan Technical Service at:

1-866-848-2698

Register your product online at:

www.titantool.com

Proper registration will serve as proof of purchase in the event your original receipt becomes misplaced or lost.

Important Safety Information



Read all safety information before operating the equipment. Save these instructions



Indicates a hazardous situation which, if not avoided, could result in death or serious injury.

- a) **To reduce the risks of fire or explosion, electrical shock and the injury to persons, read and understand all instructions included in this manual. Be familiar with the controls and proper usage of the equipment.**

Grounding Instructions

This product must be grounded. In the event of an electrical short circuit, grounding reduces the risk of electric shock by providing an escape wire for the electric current. This product is equipped with a cord having a grounding wire with an appropriate grounding plug. The plug must be plugged into an outlet that is properly installed and grounded in accordance with all local codes and ordinances.

WARNING - Improper installation of the grounding plug can result in a risk of electric shock.



If repair or replacement of the cord or plug is necessary, do not connect the green grounding wire to either flat blade terminal. The wire with insulation having a green outer surface with or without yellow stripes is the grounding wire and must be connected to the grounding pin.

Check with a qualified electrician or serviceman if the grounding instructions are not completely understood, or if you are in doubt as to whether the product is properly grounded. Do not modify the plug provided. If the plug will not fit the outlet, have the proper outlet installed by a qualified electrician.

This product is for use on a nominal 120 volt circuit and has a grounding plug that looks like the plug illustrated below. Make sure that the product is connected to an outlet having the same configuration as the plug. No adapter should be used with this product.

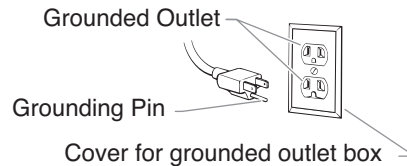

b) **WARNING - To reduce the risk of fire or explosion:**



1. Do not spray flammable or combustible materials near an open flame, pilot lights or sources of ignition such as hot objects, cigarettes, motors, electrical equipment and electrical appliances. Avoid creating sparks from connecting and disconnecting power cords.
2. Use extreme caution when using materials with a flashpoint below 70°F (21°C). Flashpoint is the temperature that a fluid can produce enough vapors to ignite.
3. Paint or solvent flowing through the equipment is able to result in static electricity. Static electricity creates a risk of fire or explosion in the presence of paint or solvent fumes. All parts of the spray system, including the pump, hose assembly, spray gun and objects in and around the spray area shall be properly grounded to protect against static discharge and sparks. Use only conductive or grounded high-pressure airless paint sprayer hoses specified by the manufacturer.
4. Verify that all containers and collection systems are grounded to prevent static discharge.
5. Connect to a grounded outlet and use grounded extension cords (electric models only). Do not use a 3 to 2 adapter.
6. Do not use a paint or solvent containing halogenated hydrocarbons. Such as chlorine, bleach mildewcide, methylene chloride and trichloroethane. They are not compatible with aluminum. Contact the coating supplier about compatibility of material with aluminum.
7. Keep spray area well ventilated. Keep a good supply of fresh air moving through the area to keep the air within the spray area free from accumulation of flammable vapors. Keep pump assembly in well ventilated area. Do not spray pump assembly.
8. Do not smoke in the spray area.

9. Do not operate light switches, engines, or similar spark producing products in the spray area.
10. Keep area clean and free of paint or solvent containers, rags, and other flammable materials.
11. Know the contents of the paint and solvents being sprayed. Read all Material Safety Data Sheets (MSDS) and container labels provided with the paints and solvents. Follow the paint and solvent manufacturer's safety instructions.
12. Place pump at least 25 feet (7.62 meters) from the spray object in a well ventilated area (add more hose if necessary). Flammable vapors are often heavier than air. Floor area must be extremely well ventilated. The pump contains arcing parts that emit sparks and can ignite vapors.
13. Plastic can cause static sparks. Never hang plastic to enclose spray area. Do not use plastic drop cloths when spraying flammable material.
14. Fire extinguisher equipment shall be present and working.

c) **WARNING - To reduce the risk of skin injection:**



1. Do not aim the gun at, or spray any person or animal.
2. Keep hands and other body parts away from the discharge. For example, do not try to stop leaks with any part of the body.
3. Always use the nozzle tip guard. Do not spray without the nozzle tip guard in place.
4. Only use a nozzle tip specified by the manufacturer.
5. Use caution when cleaning and changing nozzle tips. In the case where the nozzle tip clogs while spraying, ALWAYS lock gun trigger, shut pump off, and release all pressure before servicing, cleaning tip or guard, or changing tip. Pressure will not be released by turning off the motor. The PRIME/SPRAY valve or pressure bleed valve must be turned to their appropriate positions to relieve system pressure. Refer to PRESSURE RELIEF PROCEDURE described in the pump manual.
6. Do not leave the unit energized or under pressure while unattended. When the unit is not in use, turn off the unit and relieve the pressure in accordance with the manufacturer's instructions.
7. High-pressure spray is able to inject toxins into the body and cause serious bodily injury. In the event that injection occurs, seek medical attention immediately.
8. Check hoses and parts for signs of damage, a leak can inject material into the skin. Inspect hose before each use. Replace any damaged hoses or parts.

9. This system is capable of producing 2800 PSI / 193 Bar (100) or 3000 PSI / 207 Bar (200). Only use replacement parts or accessories that are specified by the manufacturer and that are rated a minimum of 3000 PSI. This includes spray tips, nozzle guards, guns, extensions, fittings, and hose.
10. Always engage the trigger lock when not spraying. Verify the trigger lock is functioning properly.
11. Verify that all connections are secure before operating the unit.
12. Know how to stop the unit and bleed pressure quickly. Be thoroughly familiar with the controls. Pressure will not be released by turning off the motor. The PRIME/SPRAY valve or pressure bleed valve must be turned to their appropriate positions to relieve system pressure. Refer to PRESSURE RELIEF PROCEDURE described in the pump manual.
13. Always remove the spray tip before flushing or cleaning the system.

NOTE TO PHYSICIAN:

Injection into the skin is a traumatic injury. It is important to treat the injury as soon as possible. DO NOT delay treatment to research toxicity. Toxicity is a concern with some coatings injected directly into the blood stream. Consultation with a plastic surgeon or reconstructive hand surgeon may be advisable.

d) WARNING - To reduce the risk of injury:

1. Always wear appropriate gloves, eye protection, clothing and a respirator or mask when painting. Hazardous vapors – Paints, solvents, insecticides, and other materials can be harmful if inhaled or come in contact with body. Vapors can cause severe nausea, fainting or poisoning.
2. Do not operate or spray near children. Keep children away from equipment at all times.
3. Do not overreach or stand on an unstable support. Keep effective footing and balance at all times.
4. Stay alert and watch what you are doing.
5. Do not operate the unit when fatigued or under the influence of drugs or alcohol.
6. Do not kink or over-bend the hose. Airless hose can develop leaks from wear, kinking and abuse. A leak can inject material into the skin.
7. Do not expose the hose to temperatures or pressures in excess of those specified by manufacturer.
8. Do not use the hose as a strength member to pull or lift the equipment.
9. Use lowest possible pressure to flush equipment.
10. Follow all appropriate local, state and national codes governing ventilation, fire prevention and operation.

11. The United States Government Safety Standards have been adopted under the Occupational Safety and Health Act (OSHA). These standards, particularly part 1910 of the General Standards and part 1926 of the Construction Standards should be consulted.
12. Before each use, check all hoses for cuts, leaks, abrasion or bulging of cover. Check for damage or movement of couplings. Immediately replace hose if any of those conditions exist. Never repair a paint hose. Replace with a conductive high-pressure hose.
13. Do not spray outdoors on windy days.
14. Always unplug cord from outlet before working on equipment (electric models only).

Important Electrical Information

IMPORTANT: Use only a 3-wire extension cord that has a 3-blade grounding plug and a 3-slot receptacle that will accept the plug on the product. Make sure your extension cord is in good condition. When using an extension cord, be sure to use one heavy enough to carry the current your product will draw. An undersized cord will cause a drop in line voltage resulting in loss of power and overheating. A 14 or 12 gauge cord is recommended (see chart). If an extension cord is to be used outdoors, it must be marked with the suffix W-A after the cord type designation. For example, a designation of SJTW-A would indicate that the cord would be appropriate for outdoor use.

Cord gauge	Maximum cord length
12	150 feet
14	100 feet

Do not use more than 100 feet of spray hose. If you need to spray further than 100 feet from your power source, use more extension cord, not more spray hose.

If you experience problems with your sprayer at any time during assembly, operation, or cleanup, please refer to the Troubleshooting section of this manual (page 22), or call customer service at:

1-866-848-2698

What's in the box?*

*Certain parts of the sprayer will not be assembled out of the box. Be sure to read Assembly instructions, page 6.

Start Notice:

This pump is available in a stand model (100) and cart model (200 shown right). All information given for the stand model applies to the cart model except where indicated.

Some of the graphics in this manual may not exactly match your sprayer and spray gun. All information and instructions given in this manual applies to all models except where noted.

The type of spray gun and length of spray hose included depends upon the pump model you have. Refer to the chart below for details.

Pump Model	Gun Model	Hose Length
100	LX-50	25 ft.
200	LX-50	35 ft.

Spray Gun Assembly

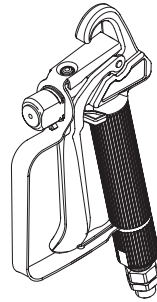

LX-50

TR² Spray Tip Assembly

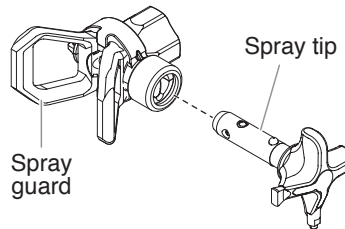

Spray Hose Assembly

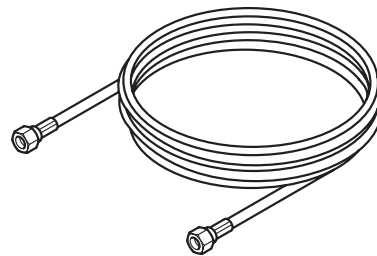

Sprayer Assembly

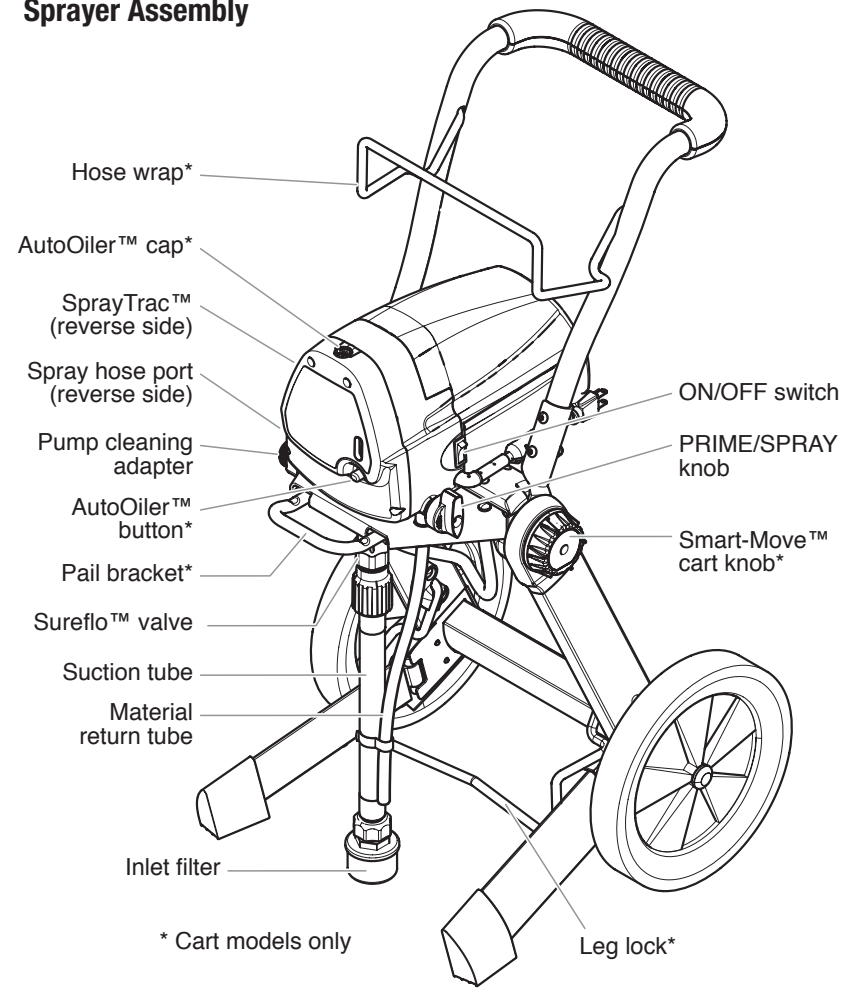

Unfolding the cart:

If you have one of the cart models (200) you will need to unfold the cart before using. Follow steps 1-4, right.

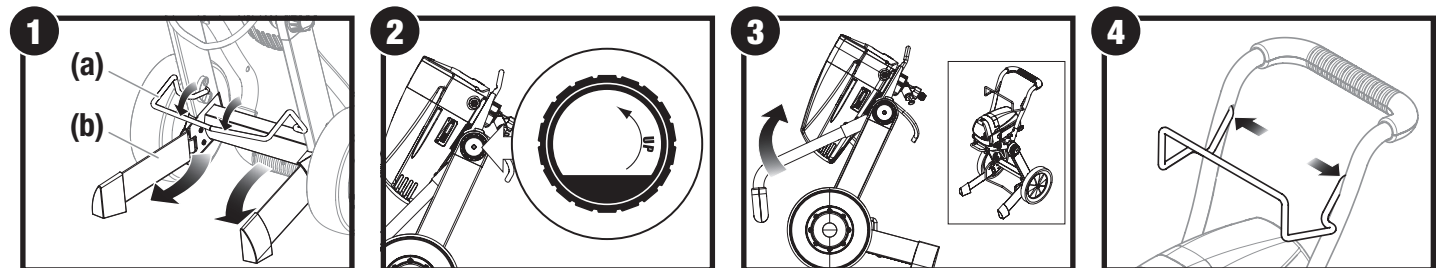

1. Lift the sprayer by the pail bracket. Lift the leg lock (a) and unfold the legs (b). Move leg lock down to lock legs into place.
2. Twist the knob on either side of the cart toward the "UP" arrow until it stops.
3. Lift the handle until the motor housing and handle locks into place. DO NOT pinch the power cord with the cart.
4. Insert the ends of the hose bracket into the holes of the handle as shown.

Proper use and functions

Start Capability:

Sprays a variety of paints (oil-based and latex), primers, stains, preservatives and other nonabrasive materials.

Do not use!

This pump should not be used with textured materials, block filler, asphalt sealer or materials containing HHC. See coating supplier if flash point is not listed on the container

Safety features:

Spray gun trigger lock and pressure diffuser; built-in tip safety guard; PRIME/SPRAY knob for safe pressure release. Conforms to UL STD 1450. Certified to CAN/CSAC 22.2 NO 68-92

Specifications:

Capacity:

100..... Up to .29 gallon (1.1 liter) / min
200..... Up to .33 gallon (1.25 liter) / min

Power source:

100..... 1/2 Hp universal motor
200..... 5/8 Hp universal motor

Power requirement: 15 amp minimum circuit on 115 VAC, 60 Hz current

Generator power requirement: 8000 Watt

Controls and Functions

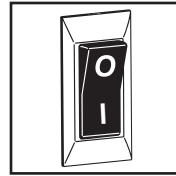

ON/OFF switch:
The ON/OFF switch turns power to sprayer on and off. (O=OFF, I=ON)

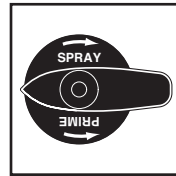

PRIME/SPRAY knob:
The PRIME/SPRAY knob directs material to the material return tube when set to PRIME or to spray hose when set to SPRAY.

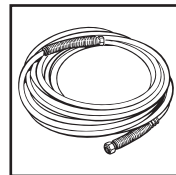

Spray hose:
The spray hose connects the spray gun to the pump.

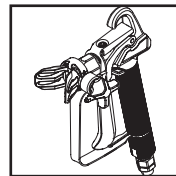

Spray gun:
The spray gun controls the delivery of the material being pumped.

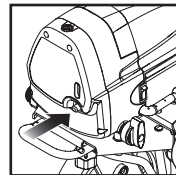

AutoOiler (200 only):
The AutoOiler is designed to provide lubrication to the fluid section of the pump.

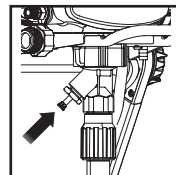

Sureflo Valve:
The Sureflo Valve is designed to keep the inlet valve open and from sticking to dried materials. The Sureflo Valve is activated manually by the user.

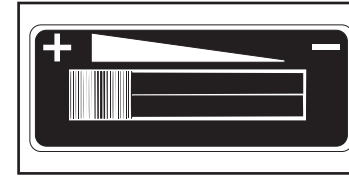

PressureTrac:
The PressureTrac™ regulates the amount of force the pump uses to push the fluid and can be adjusted for desired spray pattern.

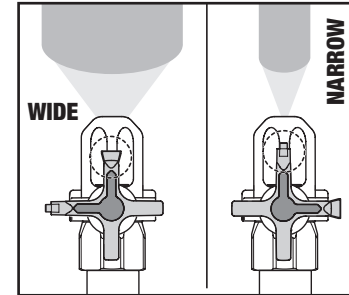

TR² spray tip:
The TR² spray tip can be adjusted based on your spraying needs.

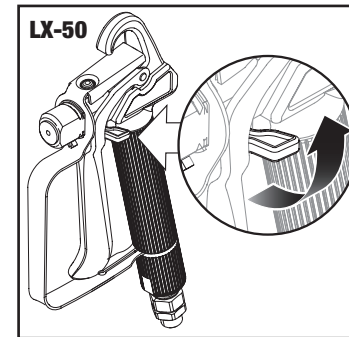

Trigger lock:
Engage the trigger lock whenever the gun is not in use.

LX-50 - The gun is locked when the trigger lock is at a 90° angle (perpendicular to the trigger in either direction).

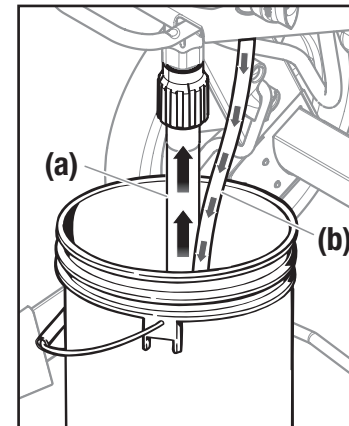

Suction tube (a):
The suction tube draws the fluid from the original container into the pump.

Material return tube (b):
Fluid is sent out through the return tube and back into the original container when the PRIME/SPRAY knob is in the PRIME position.

1. Assembly

Start You will need:

- Two adjustable wrenches

IMPORTANT: Do not plug in the power cord until assembly is complete.

Note: It will be much easier to attach the hose to the sprayer if you uncoil it first.

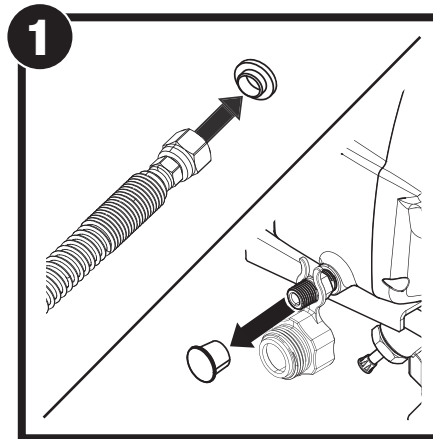
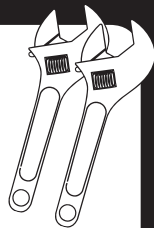

1. Remove the plug from inside the hose fittings and remove the cap on the outlet valve. Discard both.

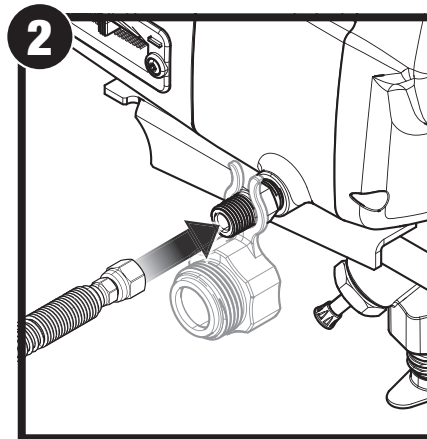

2. Thread one end of the high pressure spray hose to the spray gun port.

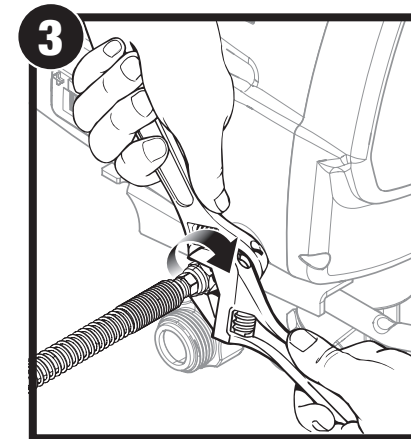

3. Hold the port with an adjustable wrench, and tighten the hose with the other.

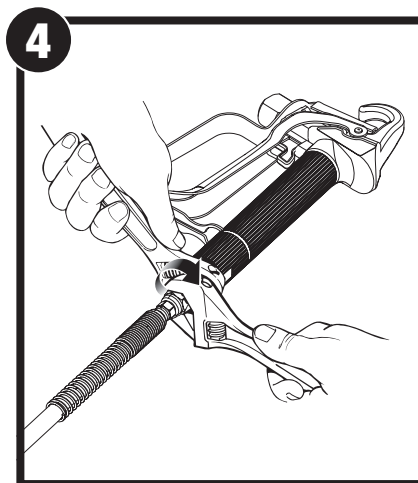

4. Thread the other end of the hose to the spray gun. Hold the gun with one adjustable wrench, and tighten the hose nut with the other.

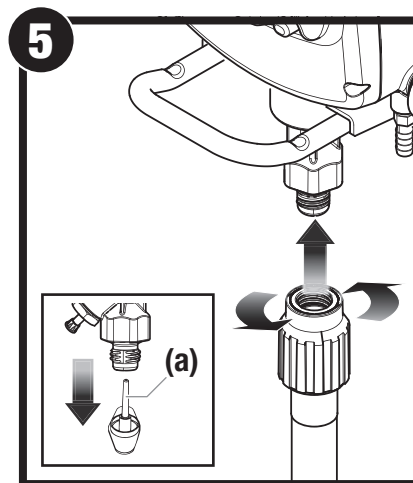

5. Remove cap from the Sureflo valve (a). Thread the suction tube onto the inlet valve and tighten firmly by hand.

Note: Be sure that the threads are straight so that the fitting turns freely.

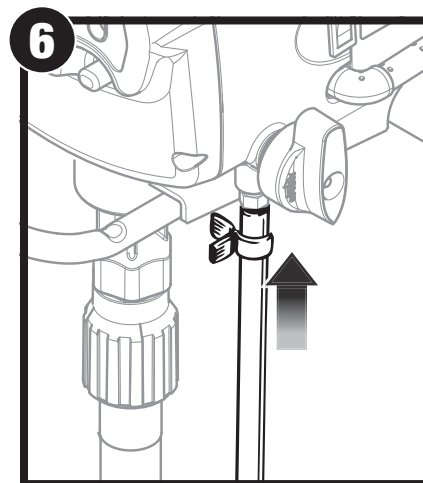

6. Press the return tube onto the return tube fitting. Squeeze clip over the return tube fitting to secure the return tube.

Pressure Relief Procedure*

*Perform when instructed

Start

Important Safety Warning



Be sure to follow the Pressure Relief Procedure when shutting the unit off for any purpose. This procedure is used to relieve pressure from the spray hose. Failure to do so could result in serious injury.

You will need:

- A waste bucket

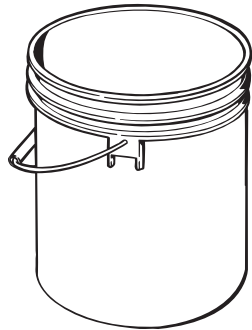

Important Safety Warning



Be careful when handling the spray gun so you don't accidentally spray yourself. The high pressure paint stream could pierce your skin causing serious injury. If an accident happens see detail procedures in the Safety Information section on pages 2-3. See physician immediately and bring this instruction manual.

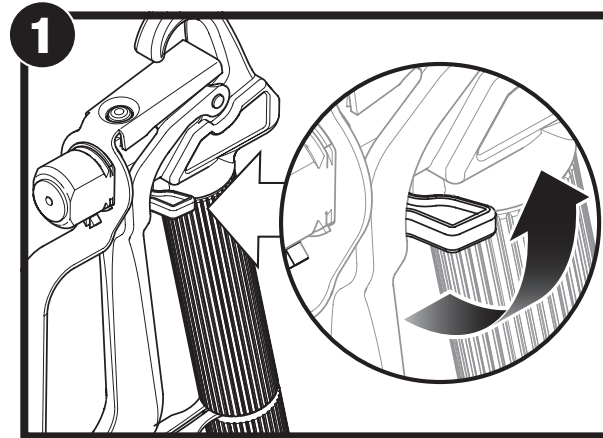
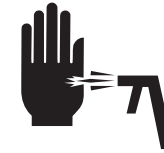

1. Lock the spray gun.

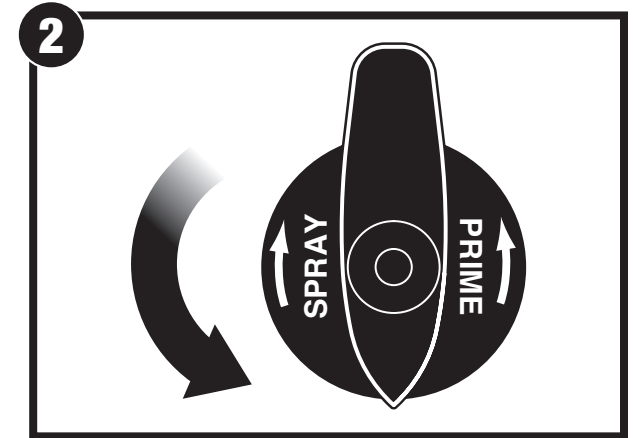

2. Turn the PRIME/SPRAY knob to PRIME.

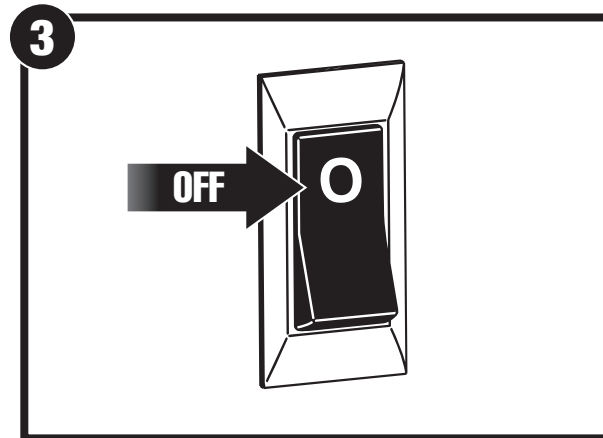

3. Turn the power OFF.

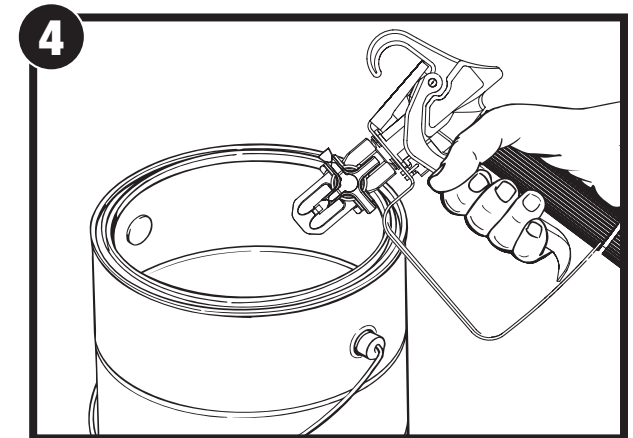

4. Unlock the spray gun. Briefly pull the trigger to fully relieve pressure from the system. Lock the spray gun.

2. Load Material

Start You will need:

- The material you plan to spray
- Flat blade screwdriver (cart models only)
- Piston Lube™
- Extension cord
- Waste bucket

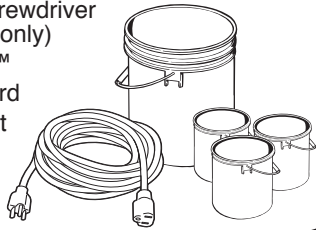

CART MODEL ONLY

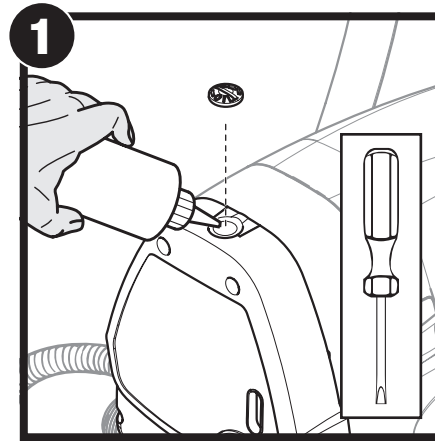

1. Remove AutoOiler cap with a flat blade screwdriver. Squirt Piston Lube into the AutoOiler. Replace cap.

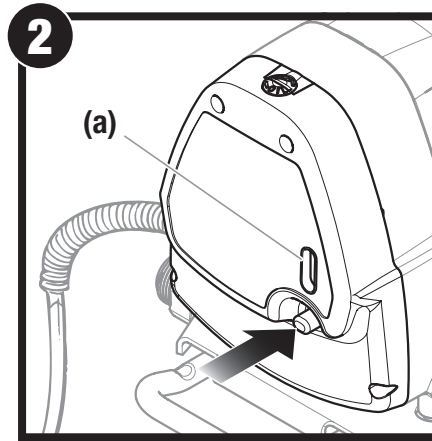

2. Push AutoOiler button 2-5 times to lubricate the fluid section. Press button 2-3 times before every use. Be sure to check reservoir level (a) and refill as necessary.

STAND MODEL ONLY

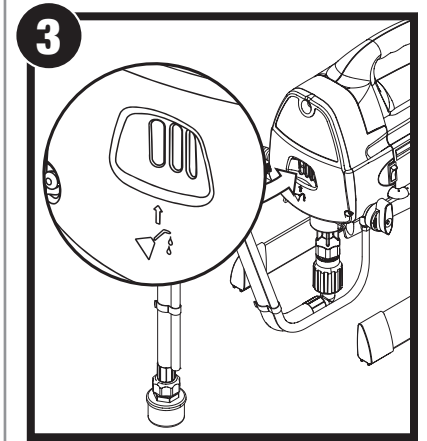

3. Squirt a teaspoon of Piston Lube™ (P/N 314-480 or 0516750, sold separately) into the indicated area. Light household oil can be substituted if necessary.

ALL MODELS

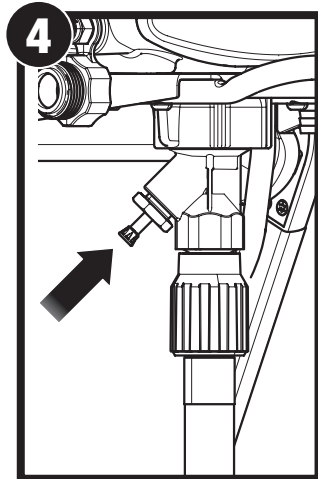

4. Fully depress the Sureflo™ valve to make sure the inlet ball is free.

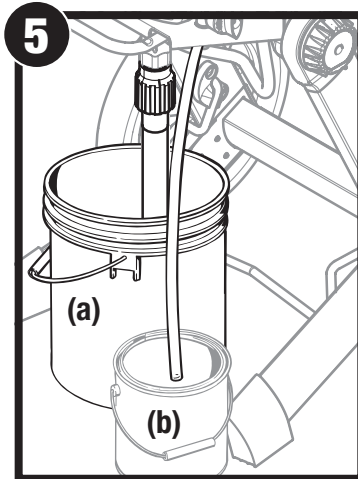

5. Place a full container of spraying material underneath the suction tube (a). Hold the return tube into a waste container (b).

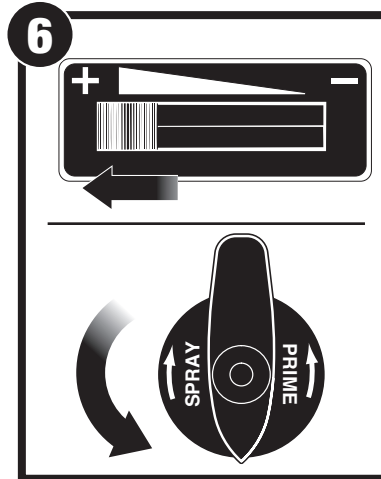

6. Slide the PressureTrac™ to maximum pressure (+). Turn the PRIME/SPRAY knob to PRIME.

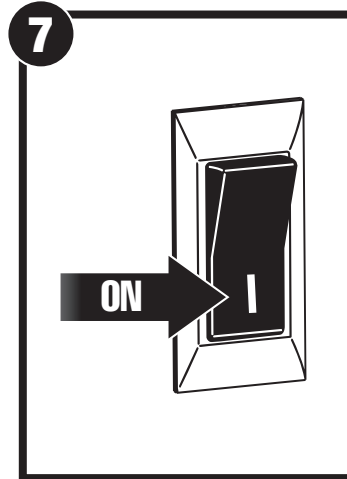

7. Plug in the sprayer and move the ON/OFF switch to the ON (I) position. **Allow pump to run until you see spray material flowing from the return tube.**

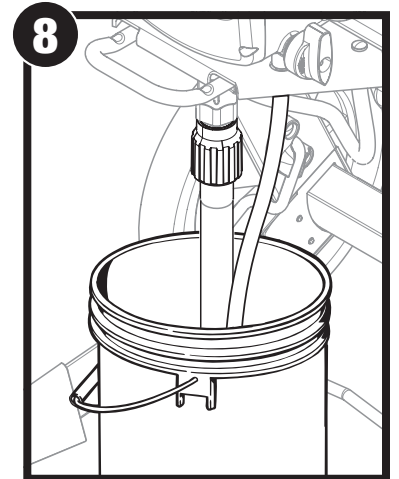

8. Switch the pump OFF (O). Place return tube back into material container and clip return tube and suction tube together.

3. Getting Material to Flow

Start You will need:

- Waste bucket
- Scrap material / cardboard
- Drop cloths to protect floors and furnishings from overspray

Note: Motor will cycle ON and OFF while spraying to regulate pressure. This is normal.

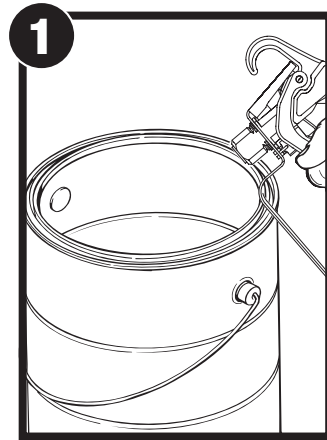

1. Point the spray gun into a separate waste container. Unlock the spray gun trigger. **Squeeze and hold trigger for steps 2-3.**

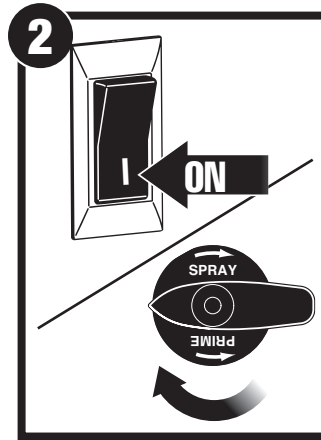

2. Turn the power ON. Turn the PRIME/SPRAY knob to SPRAY.

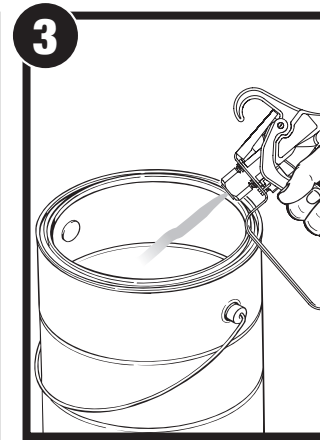

3. Continue to squeeze trigger until the material is flowing freely through the spray gun.

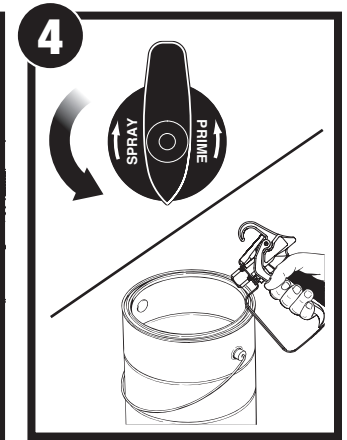

4. Perform the **Pressure Relief Procedure**, page 7.

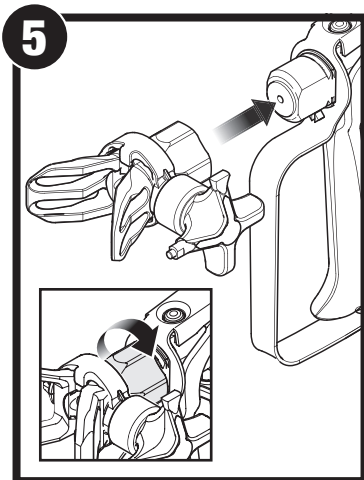

5. Thread the spray tip guard assembly onto the gun. Tighten by hand.

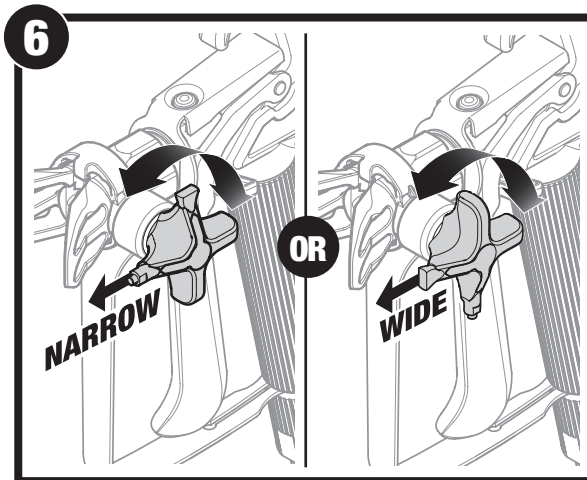

6. Rotate spray tip forward to one of the SPRAY positions. Unlock the spray gun trigger.

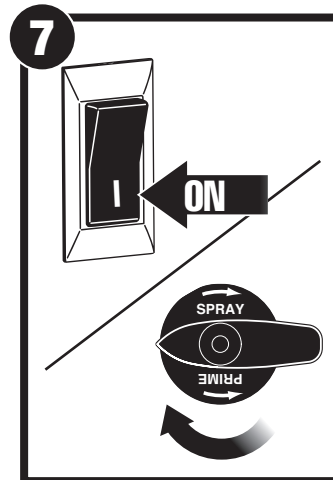

7. Turn the power ON. Turn the PRIME/SPRAY knob to SPRAY.

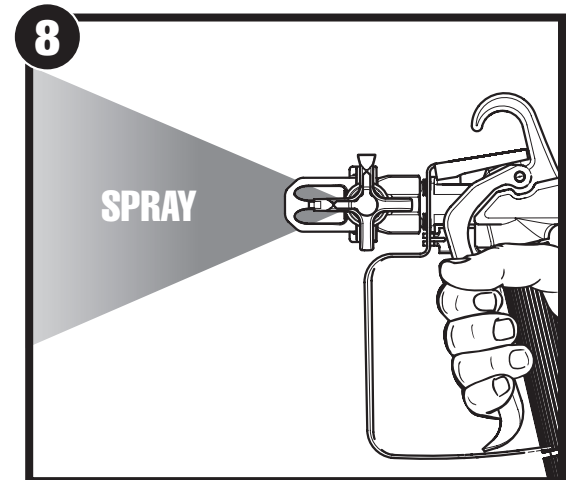

8. Point the spray gun at a piece of scrap material/cardboard. Pull the trigger and practice spraying (see pages 10-11).

Note: Motor will cycle ON and OFF while spraying to regulate pressure. This is normal.

4. Practice Spraying

Start You will need:

- Scrap material / cardboard

Notes:

If the spray pattern becomes distorted or stops completely while the gun is triggered, follow any or all the procedures listed on pages 12-14.

If you plan to be away from your spray project for more than one hour, follow the Short Term Storage instructions on page 15.

If you have difficulty achieving a good spray pattern, your spray tip and gun filter may not be ideal for the type of material you are spraying.

Spray Tip Size	Filter Color	Spray Material	Initial Pressure Setting
311	Red	Thin stains, sealers	Minimum
313	Yellow	Latex paints, stains	Maximum
413			
415			
515			
517	White	Thick latex paints, stains	Maximum

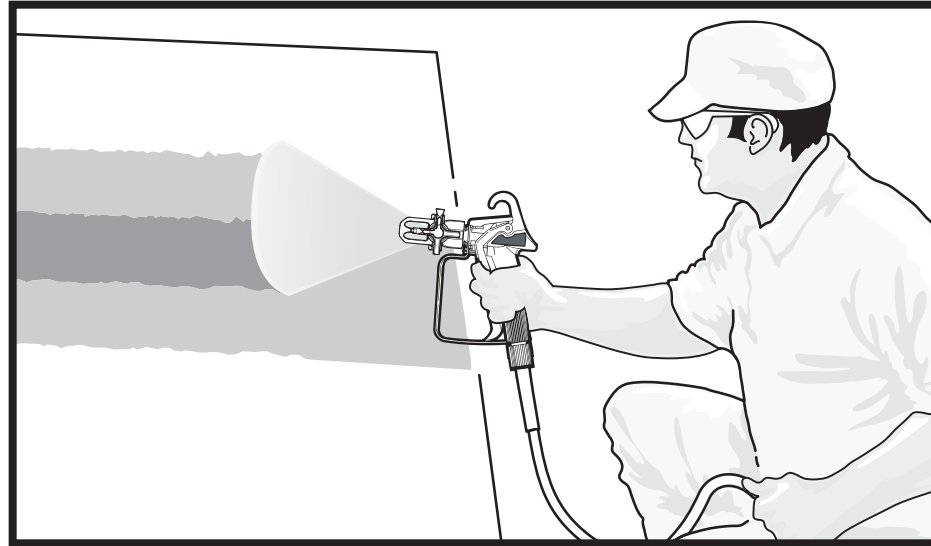

Practice on a piece of scrap material/cardboard

Tip:

Trigger gun after starting the stroke. Release the trigger before ending the stroke. The spray gun should be moving when the trigger is pulled and released. Overlap each stroke by about 50%. This will ensure an even coating.

Hold the Spray Gun Level

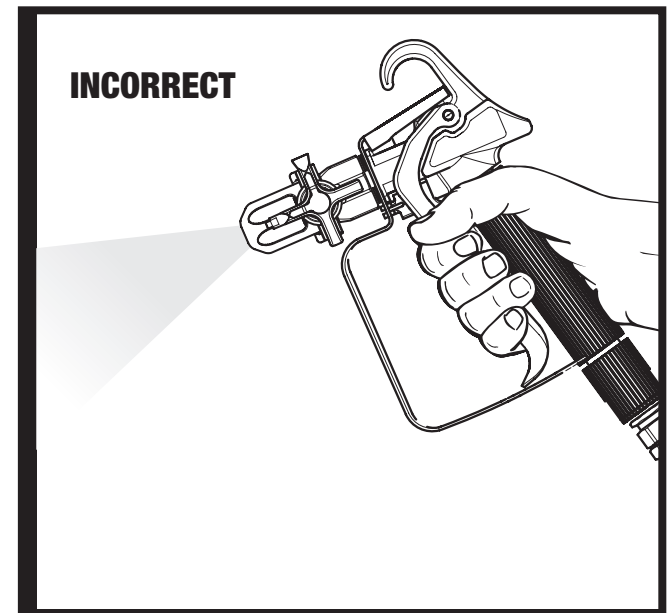
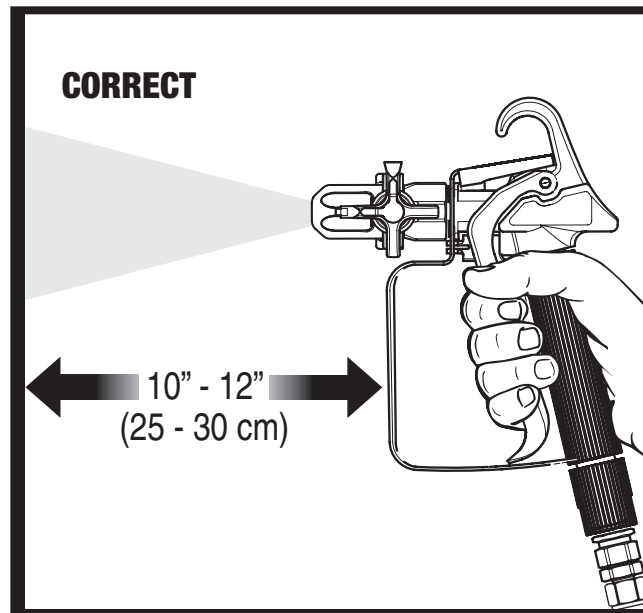

Spray Technique

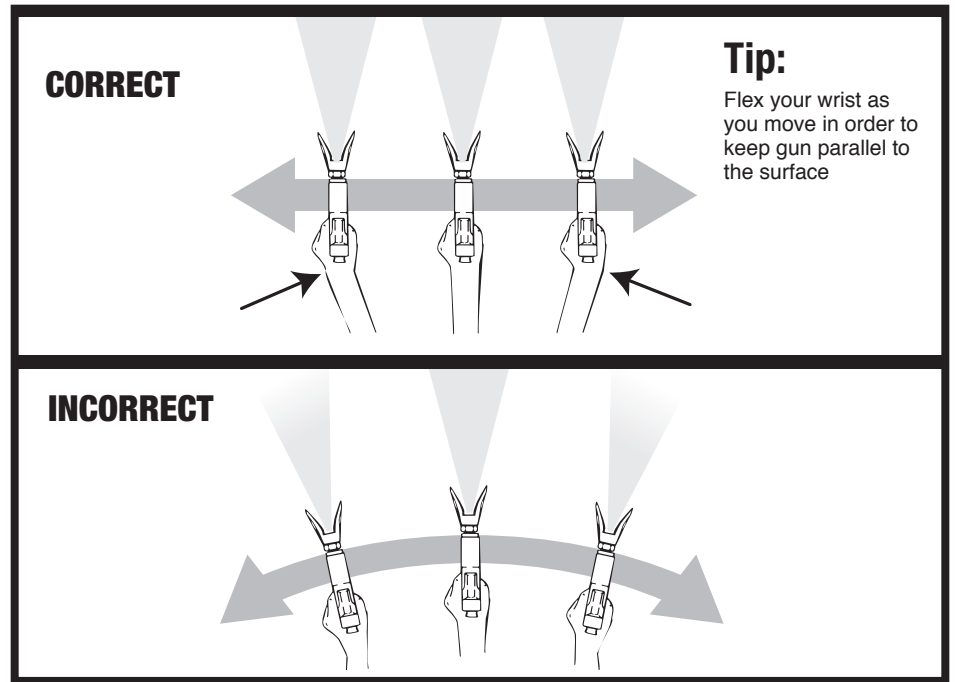
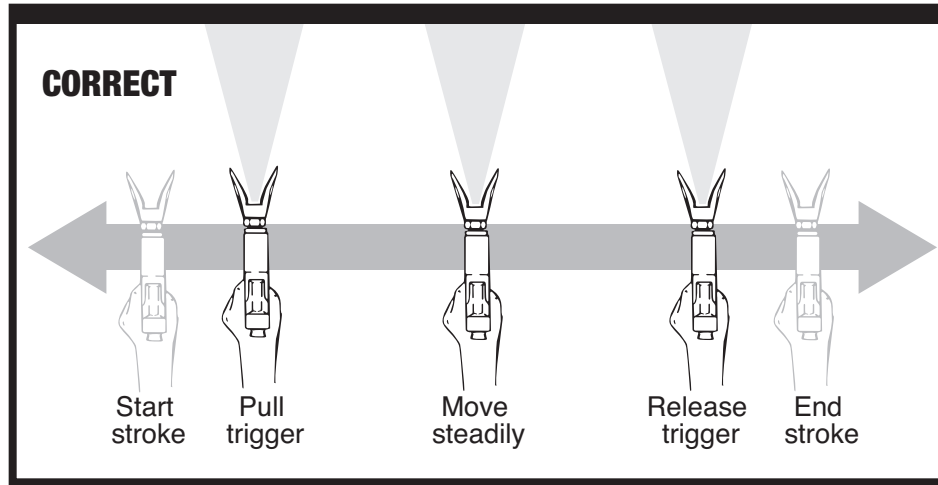

Spray Pattern

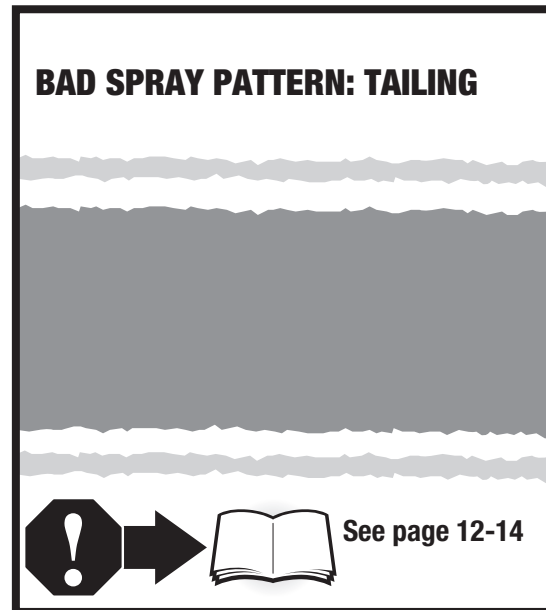
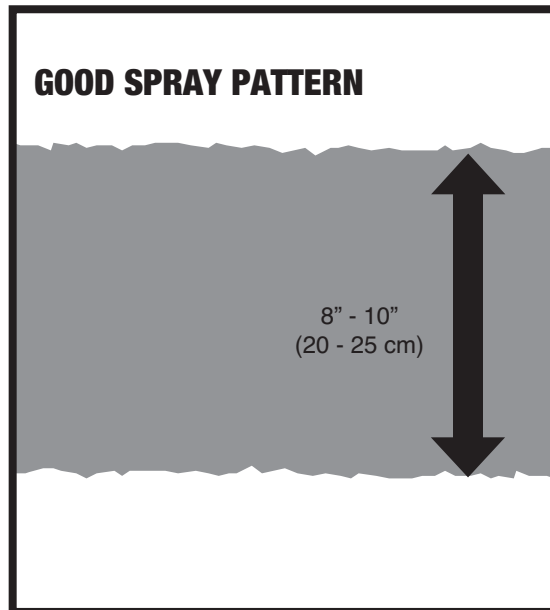

Overlap Your Strokes

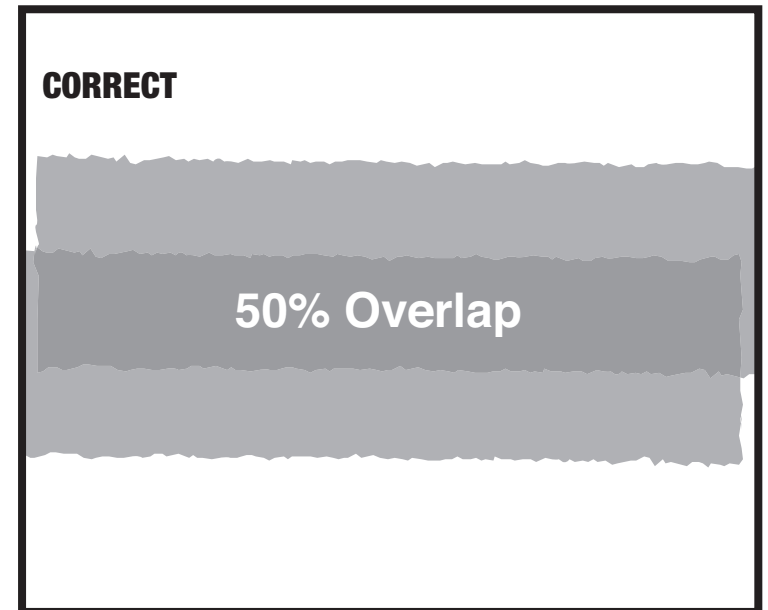

Spraying Troubleshooting -

Clear the Spray Tip

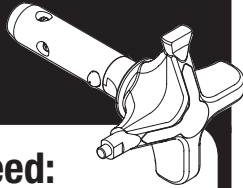

Start You will need:

- Scrap material / cardboard



Do not attempt to unclog or clean the tip with your finger. High pressure fluid can cause injection injury.

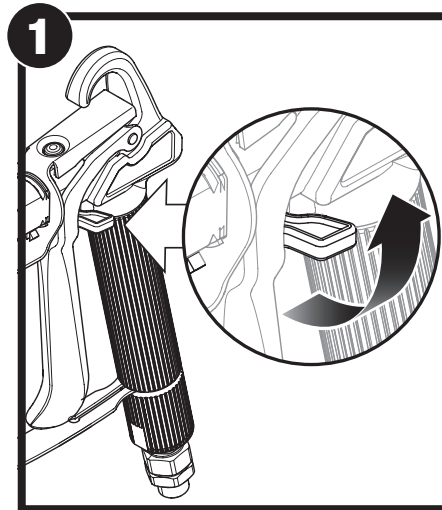

1. Lock the spray gun.

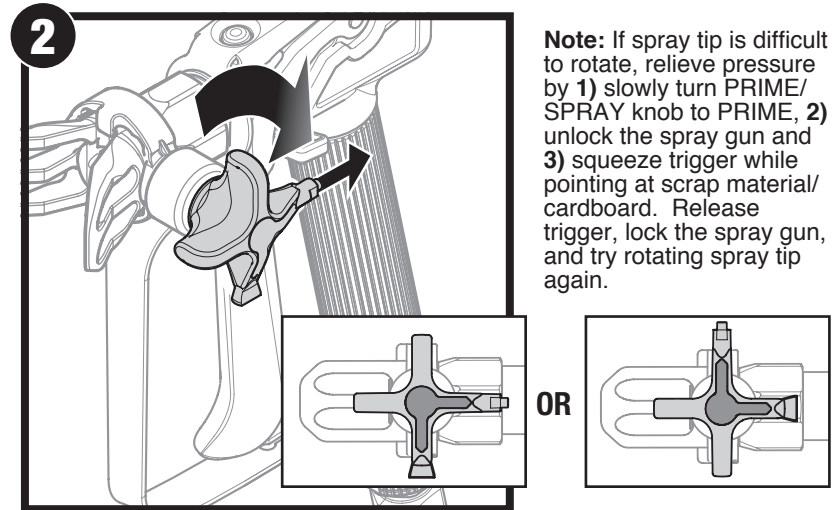

2. Rotate spray tip 180 degrees from its current position.

Note: If spray tip is difficult to rotate, relieve pressure by 1) slowly turn PRIME/SPRAY knob to PRIME, 2) unlock the spray gun and 3) squeeze trigger while pointing at scrap material/ cardboard. Release trigger, lock the spray gun, and try rotating spray tip again.

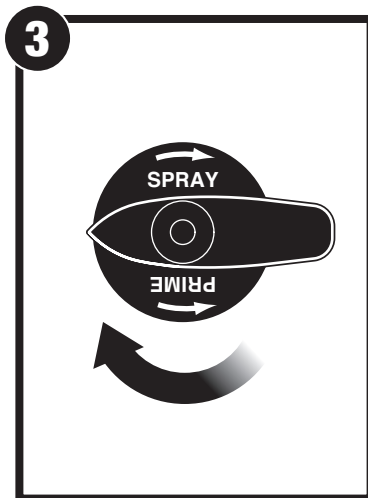

3. Make sure the PRIME/SPRAY knob is turned to SPRAY. Unlock the spray gun.

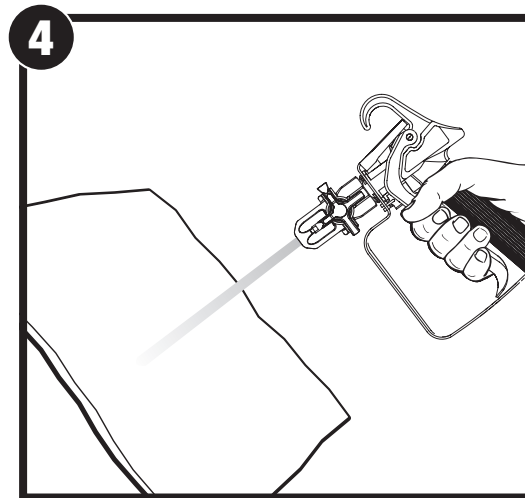

4. Point at a piece of scrap material / cardboard and squeeze trigger until material comes out in a high pressure stream. Release the trigger and lock the spray gun.

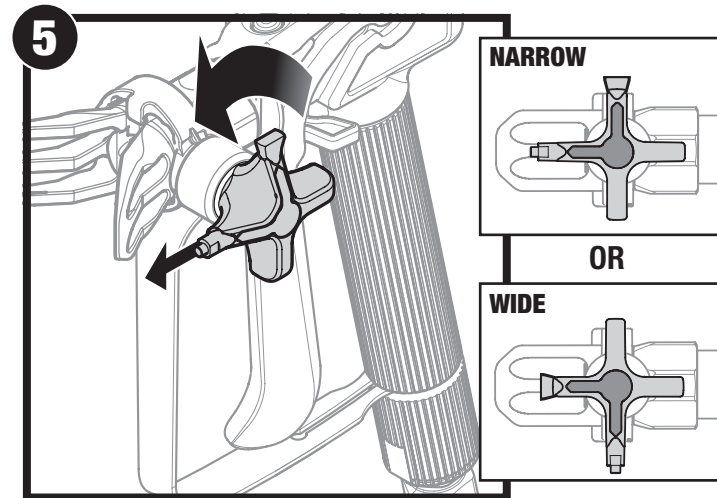

5. Rotate spray tip forward to one of the SPRAY positions. Unlock the spray gun and resume spraying.

Spraying Troubleshooting - Clean the Spray Gun Filter



Start You will need:

- Wrench
- Warm, soapy water for latex material
- Mineral spirits for oil based materials
- Replacement spray gun filter (if necessary)

IMPORTANT: Never clean the filter by poking it with a sharp object.

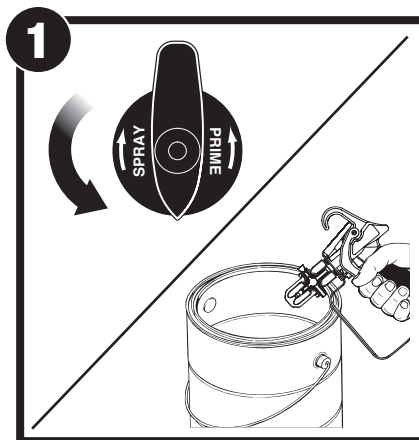

1. Perform the **Pressure Relief Procedure**, page 7.

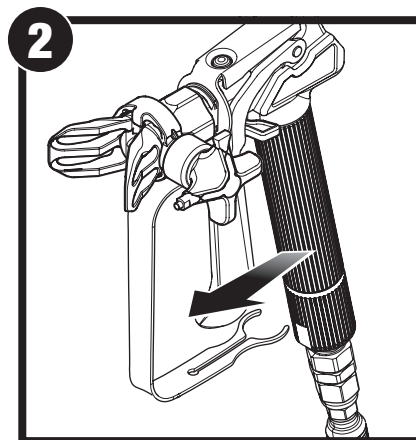

2. Pull trigger guard from filter housing.

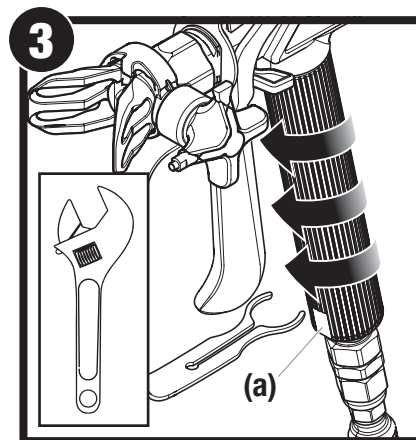

3. Tighten the wrench over the wrench flats (a). Unscrew the filter housing using a wrench.

Note: You DO NOT need to remove the spray hose from the gun to clean the filter.

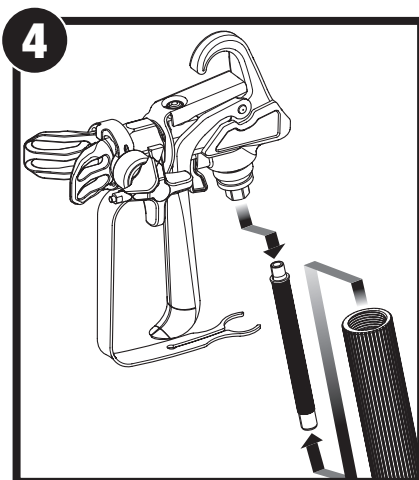

4. Remove the filter from the housing. Clean with appropriate cleaning solution (warm, soapy water for latex materials; mineral spirits for oil-based materials).

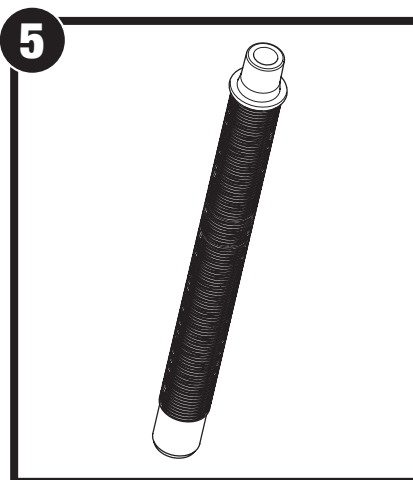

5. Inspect the filter for damage. Replace if any holes or tears are found.

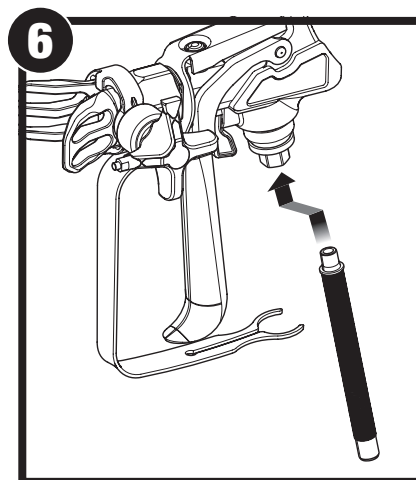

6. Replace cleaned filter, tapered end first, into the gun housing.
Note: It is important to place tapered end first to ensure proper sprayer operation.

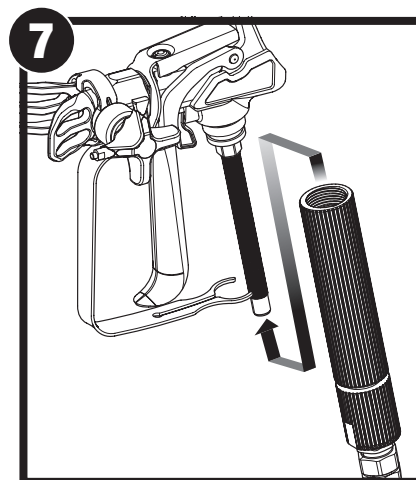

7. Reassemble the spray gun.

Spraying Troubleshooting -

Clean the Inlet Filter

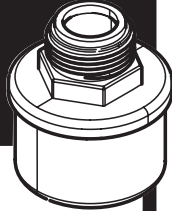

Start **You will need:**

- Warm, soapy water for latex material
- Mineral spirits for oil based materials

IMPORTANT: Make sure your floors and furnishings are covered with drop cloths to prevent accidental drips.

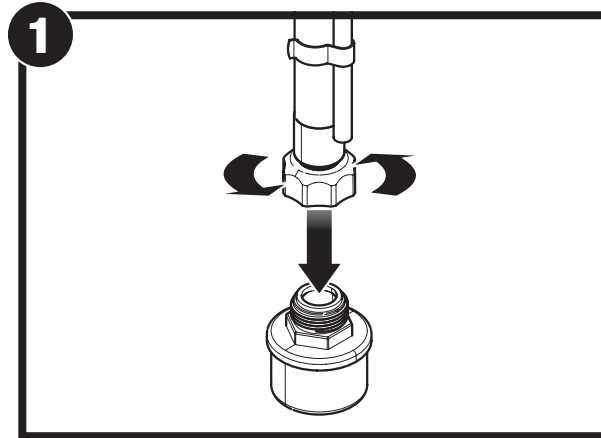

1. Unscrew the inlet filter from the fitting on the end of the suction tube.



2. Clean the filter using the appropriate cleaning solution (warm, soapy water for latex materials, mineral spirits for oil-based materials).

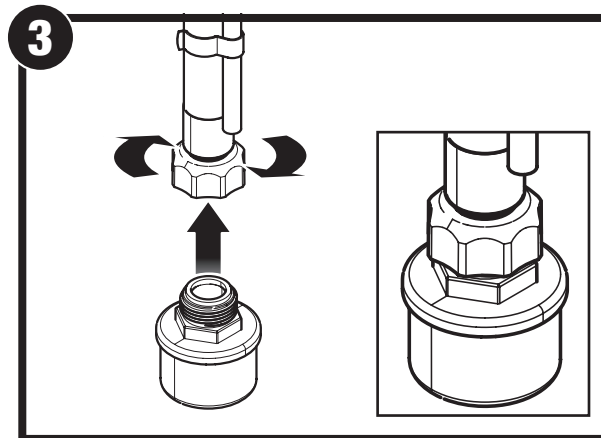

3. Replace the cleaned filter by threading it back into the fitting on the end of the suction tube.

Note: If after completing all of the steps in **Spraying Troubleshooting** you are still experiencing problems spraying, refer to the Troubleshooting section (page 22).

Short Term Storage

Start You will need:

- Water
- Plastic bag or bucket
- Rags
- Stir stick

This procedure should be used when taking a short term break or when ending your project for the day. If your break is longer than 16 hours follow Cleanup instructions, page 16.

Instructions are for latex materials only

Note: If using oil based material follow instructions for Cleanup on page 16.

Shutdown

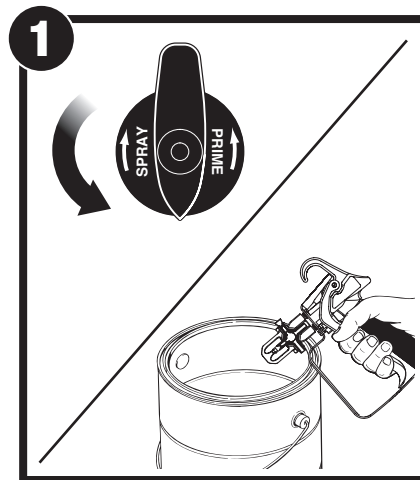

1. Perform the **Pressure Relief Procedure**, page 7.

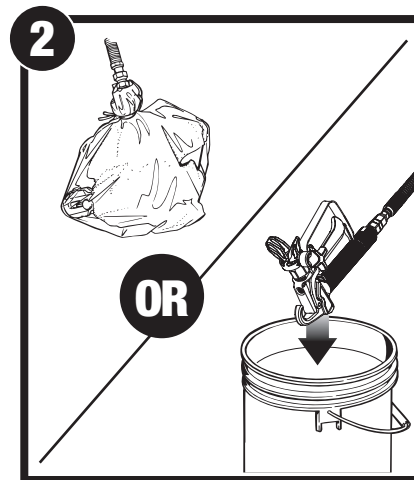

2. Place spray gun in plastic bag or immerse into bucket of water.

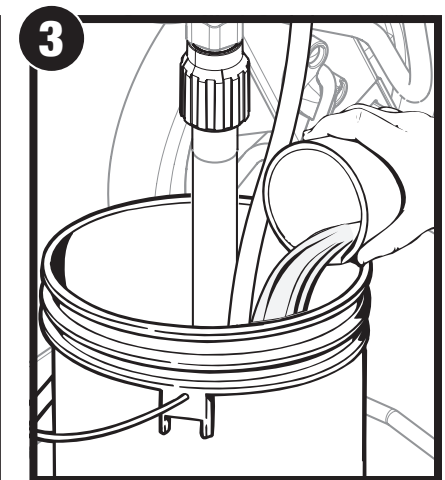

3. Pour 1/2 cup water slowly on the top of the paint to prevent the paint from drying. Place the entire spraying system out of the sun.

Startup

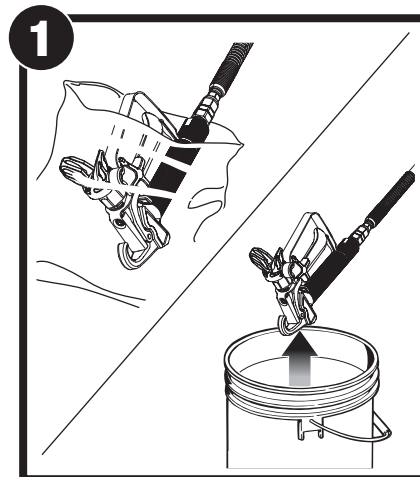

1. Remove the spray gun from the plastic bag or the water.

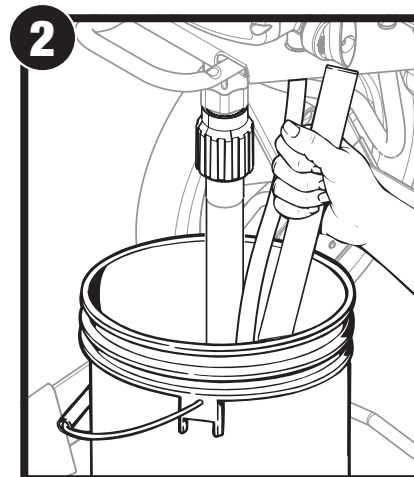

2. If water was added during shut down, stir water into material with the stir stick.

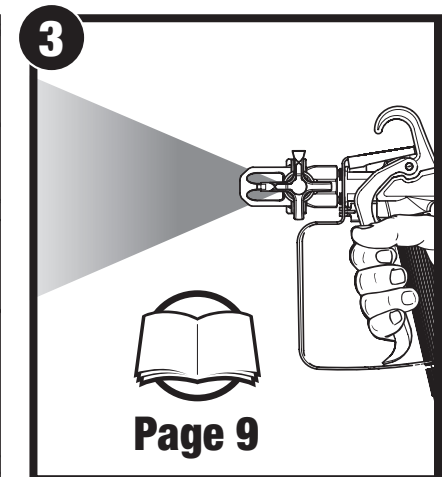

3. Follow **Getting Material to Flow** instructions, page 9.

Cleanup



or



Start You will need:

- A water source that can be delivered with a garden hose (latex materials only)
- Mineral spirits if using oil-based material
- Empty waste container
- A container with warm, soapy water

Cleaning notes - read before cleaning

- When using latex material, clean sprayer and components with warm, soapy water. For oil based material use mineral spirits. Never use mineral spirits with latex materials.
- NEVER use gasoline to clean sprayer.
- Dispose of used cleaning solution properly.
- Thorough cleaning and lubrication of sprayer is important to ensure proper operation after storage.
- If you flush your sprayer with mineral spirits, repeat **Cleanup** instructions using warm, soapy water.

Follow these steps whenever cleaning with mineral spirits:

- If spraying or cleaning with oil-based materials, the spray gun must be grounded while preparing the spray hose or cleaning.
- Ground the gun by holding it against the edge of a metal container while purging. Failure to do so may lead to a static electric discharge which may cause a fire.
- Always flush spray gun at least one hose length from spray pump.
- If collecting flushed solvent in one gallon metal container, place it into an empty five gallon container, then flush.
- Area must be free from vapors.
- Follow all cleanup instructions.

Cleanup - Latex materials



Follow these steps if you used latex materials and if you have a garden hose available. If you do not have a garden hose available, follow the [Cleanup - Oil-Based Materials](#) instructions on page 18.

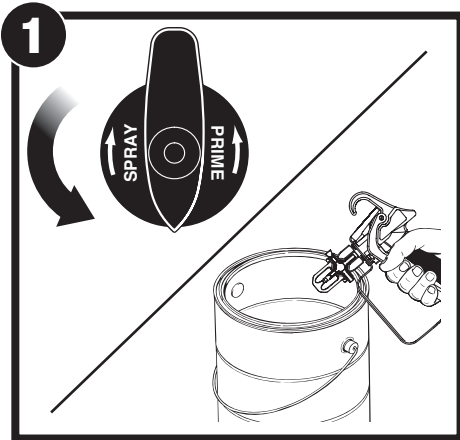

1. Perform **Pressure Relief Procedure** (page 7).

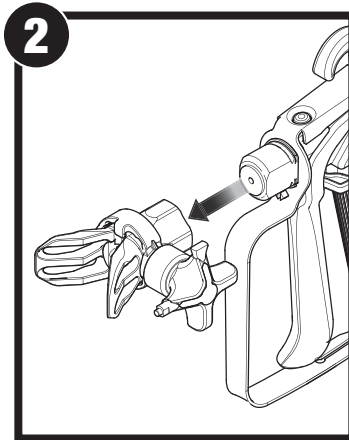

2. Remove the spray tip and place into container filled with warm, soapy water.

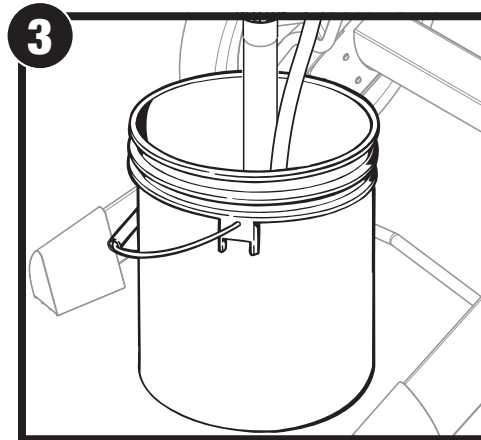

3. Place the suction tube and return tube into an empty waste container.

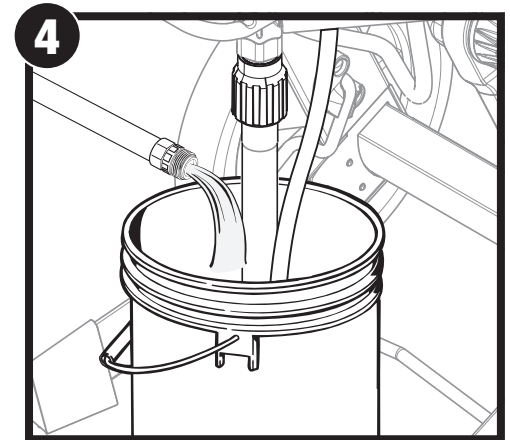

4. Using a garden hose, rinse off the suction tube, return tube and inlet filter. Empty the waste container of all fluids.

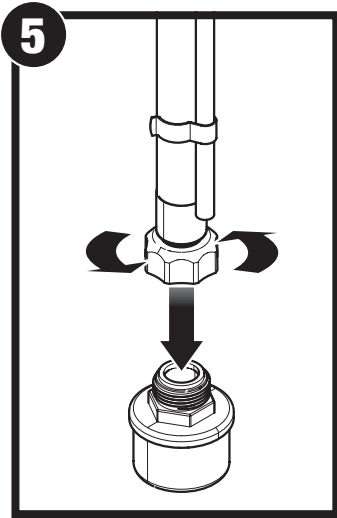

5. Remove the inlet filter from the suction tube and place it into waste container.

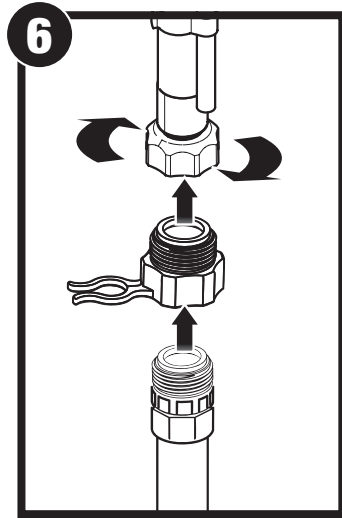

6. Thread pump cleaning adapter onto garden hose. Thread suction tube fitting over the adapter.

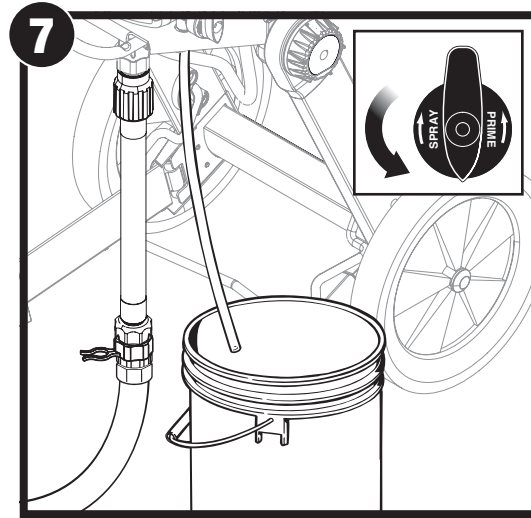

7. Unclip the return tube from the suction tube and place it into the waste container. Turn the PRIME/SPRAY knob to PRIME.

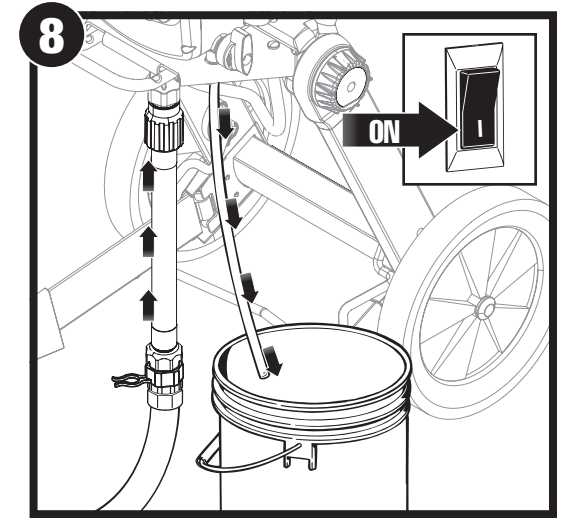

8. Turn the water supply to the garden hose on. Turn the pump ON. Water will go into the suction tube and out through the return tube. Let the pump run for a few minutes, and leave pump running for next steps.

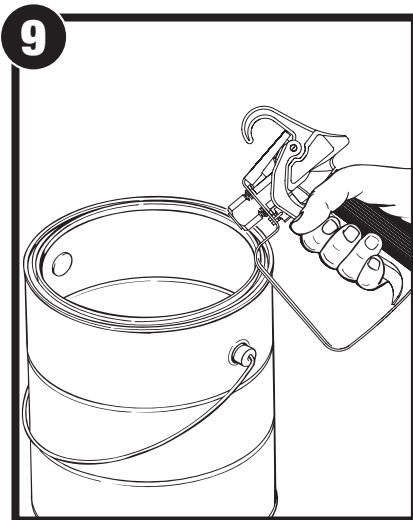

9. Point the spray gun at the side of a waste container.

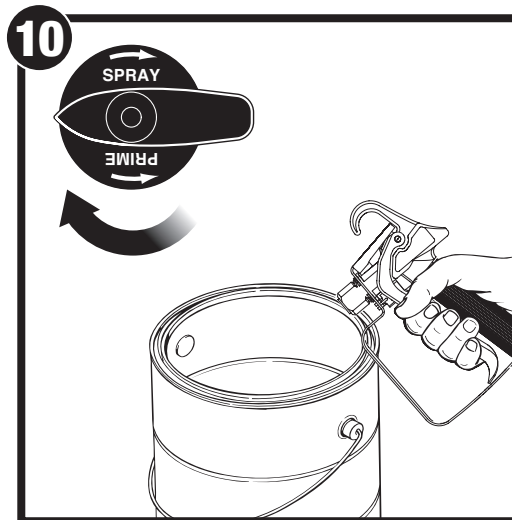

10. While squeezing the trigger, turn the PRIME/SPRAY knob to SPRAY.



11. Continue squeezing the trigger until fluid is coming out clear.

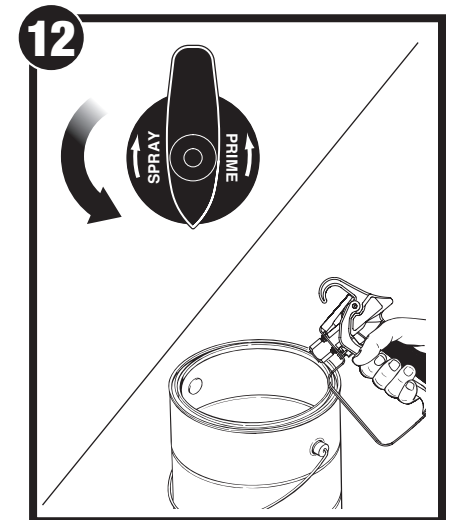

12. Perform **Pressure Relief Procedure**, page 7.

Move on the **Cleaning the Spray Gun Components**, page 19.

Cleanup - Oil-Based Materials

Start You will need:

- Mineral spirits if using oil-based material
- Warm, soapy water if using latex material
- Waste container

Follow these steps if you sprayed oil-based materials, or if you sprayed latex materials and do not have a garden hose available. Be sure to use the appropriate cleaning solution for the type of material sprayed.

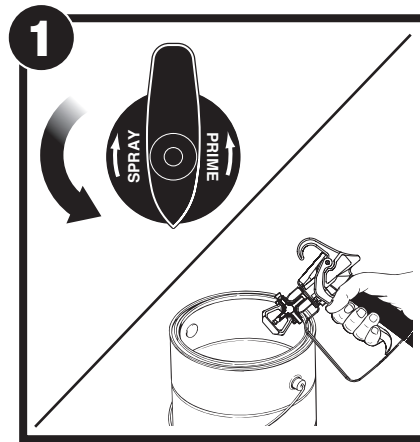

1. Perform **Pressure Relief Procedure** (page 7).

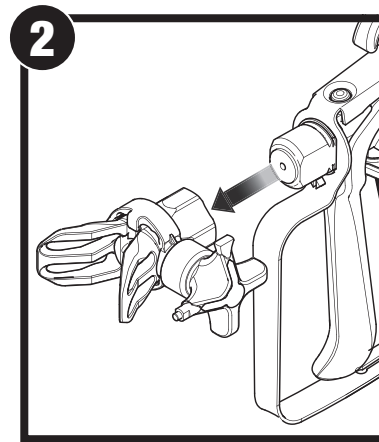

2. Remove the spray tip and place into an empty waste container.

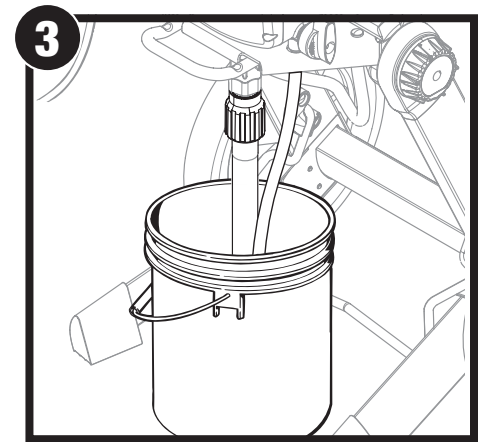

3. Submerge suction set into a bucket with the appropriate cleaning solution.

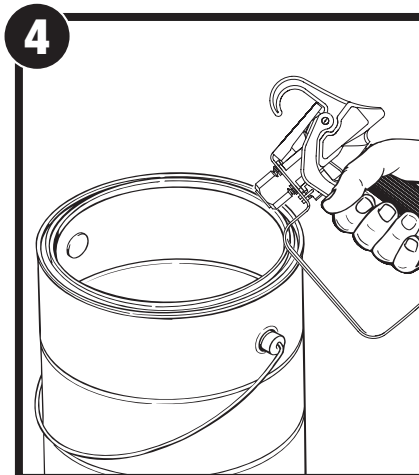

4. Point the spray gun at the side of a waste container.
Ground the gun against the side of a metal waste container if flushing with mineral spirits.

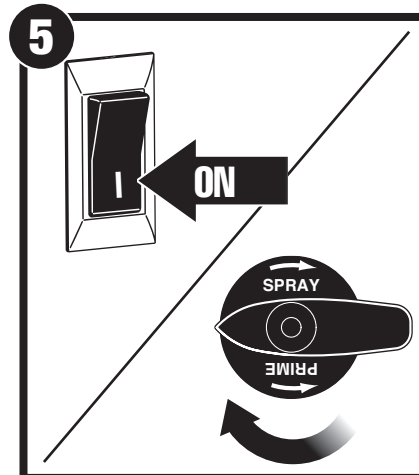

5. While squeezing the trigger, turn the power ON, and turn the PRIME/SPRAY knob to SPRAY.

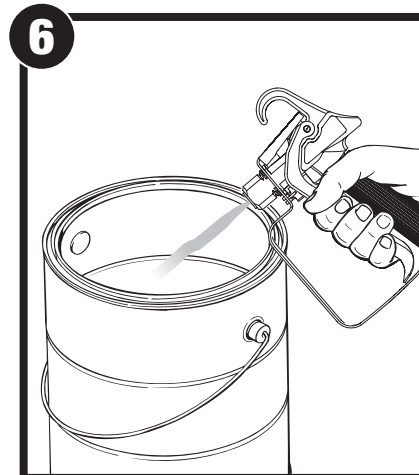

6. Continue squeezing the trigger until fluid is coming out clear. You may need to get new cleaning solution.

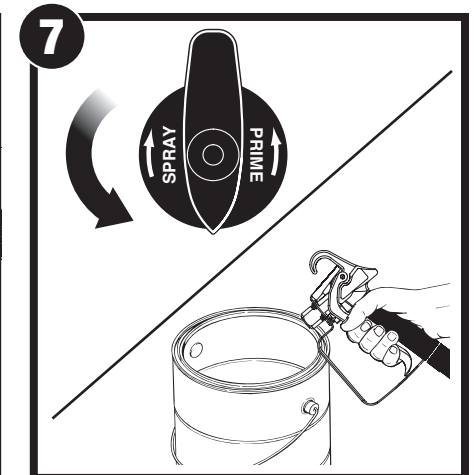

7. Perform **Pressure Relief Procedure**, page 7.

If you flushed the sprayer with mineral spirits repeat the steps on this page using warm, soapy water.

Cleaning the Spray Gun Components

Start You will need:

- Soft bristled brush
- Light household oil
- Warm, soapy water if using latex material
- Mineral spirits for oil based material
- Wrench

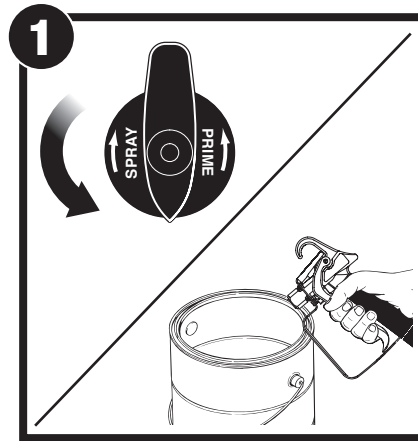

1. Perform the **Pressure Relief Procedure**, page 7.

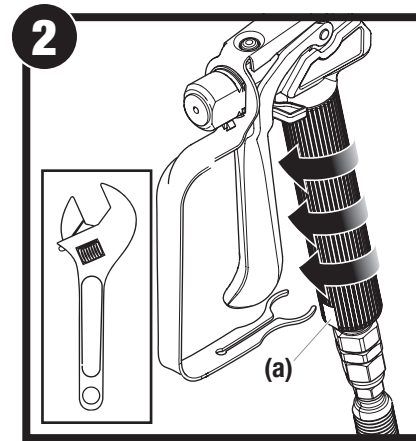

2. Pull trigger guard to separate from filter housing and unscrew housing using a wrench.

Note: Tighten the wrench over the wrench flats (a).

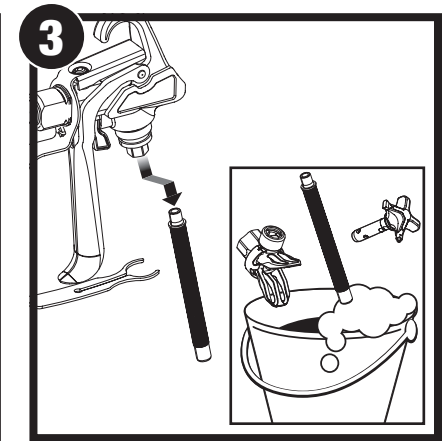

3. Remove filter from spray gun. Clean spray tip and filter with soft bristled brush and appropriate cleaning solution.

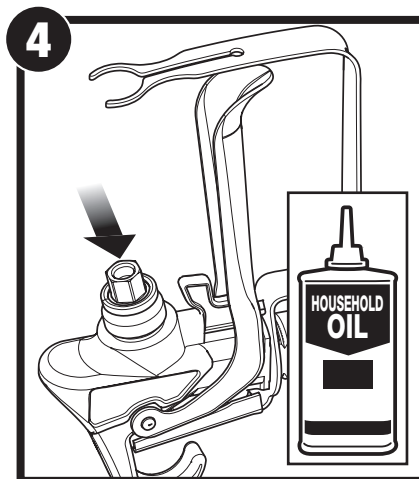

4. Pour a few drops of light household oil inside gun housing.

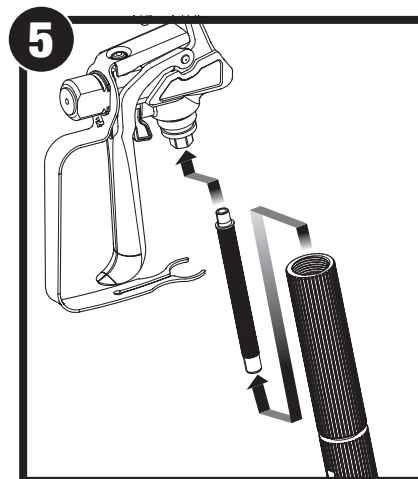

5. Install gun filter tapered-end first. Reassemble spray gun.

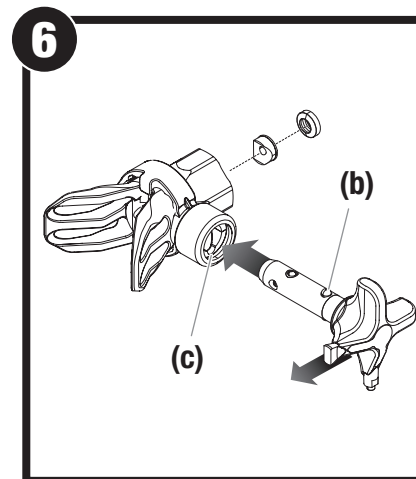

6. Line up the tabs (b) on the spray tip with the slots in the guard assembly. Slide the tip into the guard.

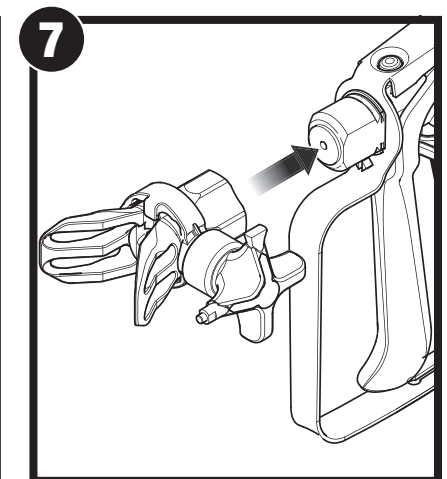

7. Install spray tip and guard assembly. Move on to **Long Term Storage**, page 20.

Long Term Storage

Start You will need:

- Light household oil / Piston Lube
- Rags
- Wrench

IMPORTANT: Store the unit indoors with the power cord wrapped around the cart handle.

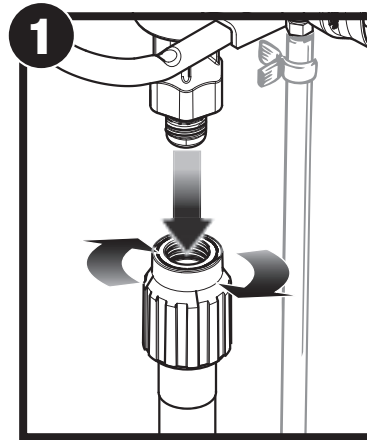
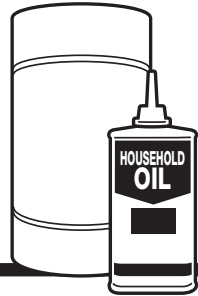

1. Remove the suction tube. Using a wrench, remove the spray hose.

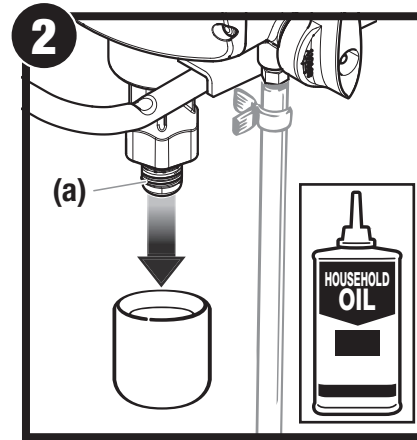

2. Fill a cup or other container with two ounces of Piston Lube and submerge the Sureflo Valve (a) into the oil. Light household oil can be substituted.

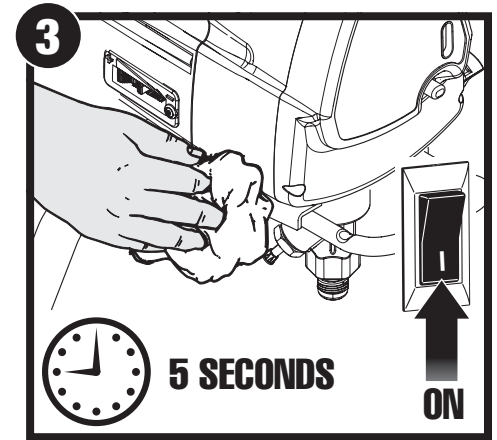

3. Cover the outlet valve with a rag. Turn power ON and let the pump run for five seconds. Turn power OFF.

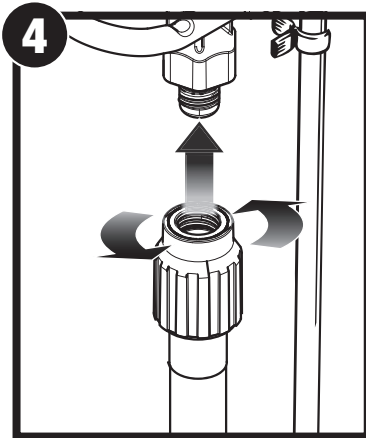

4. Replace suction tube.

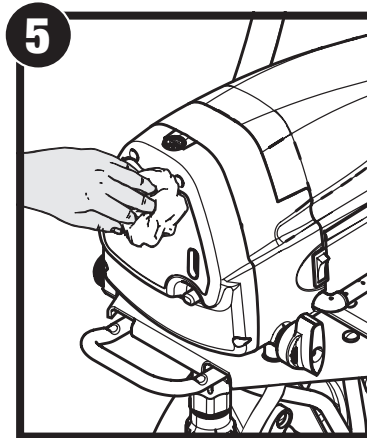

5. Wipe entire unit, hose, and spray gun to remove accumulated spray material.

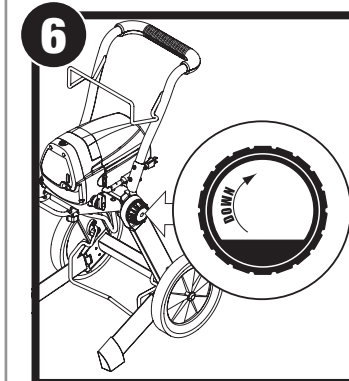

6. With one hand on the handle, twist the knob on either side of the cart toward the "DOWN" arrow.

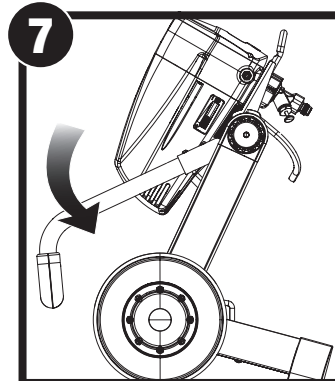

7. When the knob is fully "DOWN", this will release the handle and it can be folded down until it is locked into place. **Be careful not to pinch the power cord with the cart.**

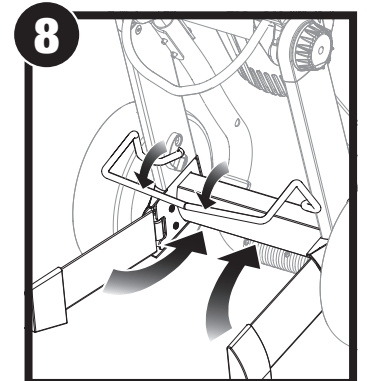

8. Lift the leg lock, and fold the legs in. Replace the leg lock to hold the legs into place.

CART MODELS ONLY

STOP DO NOT perform this step if you intend to collapse the cart for storage.

Cleaning the Sureflo Valve

Start You will need:

- Wrench

Cleaning or servicing the Sureflo Valve may be required if the unit has priming problems. Priming problems may be prevented by properly cleaning the sprayer and following the long-term storage steps.

If priming problems persist, you may need to replace the Sureflo Valve assembly. Call Technical Service (1-866-848-2698) to order new Sureflo™ valve assembly.

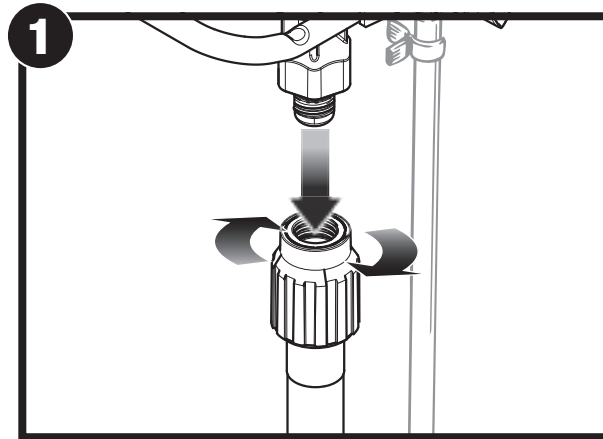

1. Remove the suction tube.

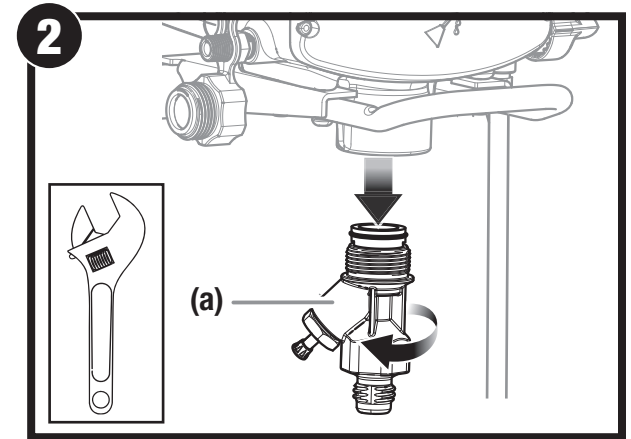

2. Unscrew the Sureflo Valve assembly (a) from the sprayer. Visually inspect the inside and outside of the Sureflo Valve assembly. Clean any paint residue with the appropriate cleaning solution.

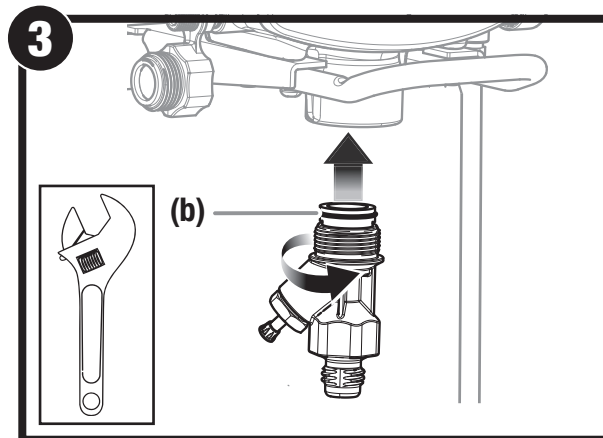

3. Lubricate the O-ring on the Sureflo Valve (b) with petroleum jelly. Replace Sureflo Valve assembly by screwing it into the sprayer. Tighten with the wrench.

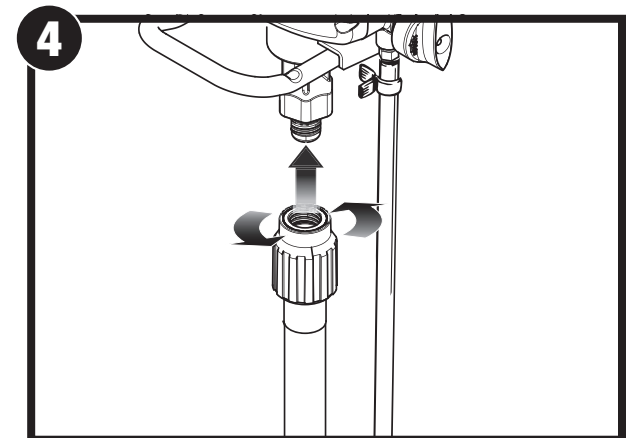

4. Replace suction tube and hand-tighten.

Troubleshooting



Before servicing, always release system pressure by following Pressure Relief Procedure (page 7).

Problem A: The sprayer does not start

Cause	Solution
1. Sprayer is not plugged in	Plug sprayer in
2. ON/OFF switch is set to OFF	Turn ON/OFF switch to ON
3. The sprayer shuts off while under pressure	Motor will cycle ON and OFF while spraying to regulate pressure. This is normal.
4. No voltage is coming from wall plug	Test the power supply voltage
5. The extension cord is damaged or has too low a capacity	Replace extension cord
6. There is a problem with sprayer motor	Take sprayer to Titan Authorized Service Center

Problem B: The sprayer starts but does not draw material when the PRIME/SPRAY knob is set to PRIME

Cause	Solution
1. The inlet valve is stuck	Inlet may be stuck from old material. Push Sureflo Valve to release. If still stuck refer to Clean the Inlet Filter see page 14 or Cleaning the Sureflo Valve see page 21
2. The sprayer will not prime properly or has lost prime	Refer to Getting Material to Flow section see page 9
3. The suction set is not properly installed	Reinstall the suction set see page 6
4. The material container is empty	Refer to Load Material and Getting Material to Flow sections see pages 8-9
6. The inlet filter is clogged	Refer to Clean the Inlet Filter see page 14
7. The outlet valve is stuck	Call Technical Service
8. The inlet valve is worn or damaged	Take sprayer to Titan Authorized Service Center
9. The PRIME/SPRAY valve is plugged	Take sprayer to Titan Authorized Service Center

Problem C: The sprayer draws up material but the pressure drops when the gun is triggered (bad spray pattern)

Cause	Solution
1. Pressure too low	Increase the pressure by sliding the PressureTrac to the left
2. The spray tip is worn	Replace spray tip with a new one**
3. The inlet filter is clogged	Refer to Clean the Inlet Filter see page 14
4. The spray tip is plugged	Refer to Clear the Spray Tip see page 12
5. The spray gun filter is clogged	Refer Clean the Spray Gun Filter see page 13 . Keep extra filters on hand
6. The material is too heavy or coarse	Thin or strain the material
7. The Sureflo™ Valve assembly is damaged or worn	Replace the Sureflo Valve see page 21

Problem D: The PRIME/SPRAY knob is set to SPRAY and there is flow through the material return tube

Cause	Solution
1. The PRIME/SPRAY valve is dirty or worn	Take sprayer to Titan Authorized Service Center

Problem E: The spray gun leaks

Cause		Solution
1.	Gun filter housing is loose	Tighten handle
2.	Internal parts of spray gun are worn or dirty	Take sprayer to Titan Authorized Service Center

Problem F: The spray tip assembly leaks

Cause		Solution
1.	The spray tip was assembled incorrectly	Check tip assembly and assemble properly see page 19, steps 6-7
2.	Gun seal is worn	Replace the seal**

Problem G: The spray gun will not spray

Cause		Solution
1.	The spray tip plugged	Refer to Clear the Spray Tip see page 12
2.	The spray gun filter is clogged	Refer to Clean the Spray Gun Filter see page 13 . Keep extra filters on hand
3.	The spray tip is in wrong position	Rotate spray tip to one of the spraying positions see page 12, step 5
4.	PRIME/SPRAY knob not set on SPRAY	Turn PRIME/SPRAY knob to SPRAY see page 9 Getting Material to Flow

Problem H: The spray pattern is poor (tailing)

Cause		Solution
1.	Pressure too low	Increase the pressure by sliding the PressureTrac to the left
2.	The spray tip is plugged	Refer to Clear the Spray Tip see page 12
3.	The inlet filter is clogged	Refer to Clean the Inlet Filter see page 14
4.	The spray gun filter is clogged	Refer to Clean the Spray Gun Filter see page 13 . Keep extra filters on hand
5.	The spray tip is worn	Replace the spray tip
6.	The material is too thick	Thin material using appropriate thinning solution
7.	Pressure loss	Refer to Causes and Solutions for Problem C

Problem I: The spray tip will not turn

Cause		Solution
1.	High pressure has locked the spray tip in place	Refer to Clear the Spray Tip see page 12

** Additional parts are available for this procedure. Refer to the [Parts List](#) (page 74) section of this manual for a list of the parts and their part numbers

Daily Maintenance

The only daily maintenance necessary is thorough cleaning. Follow the cleaning procedures in this manual.

Extended Maintenance

Some pump parts eventually wear out from use and must be replaced. The following is a list of available repair kits. Pump performance is the only reliable indicator of when to replace wear parts. Refer to the Troubleshooting section for more information on when to use these kits

Kit Part

Description

0516701

Fluid Section Seal Kit (100, 200)

0552946

Saddle seat/seal kit

Parts List • Liste de Pièces • Lista de Piezas

Sprayer • Pulvérisateur • Rociador

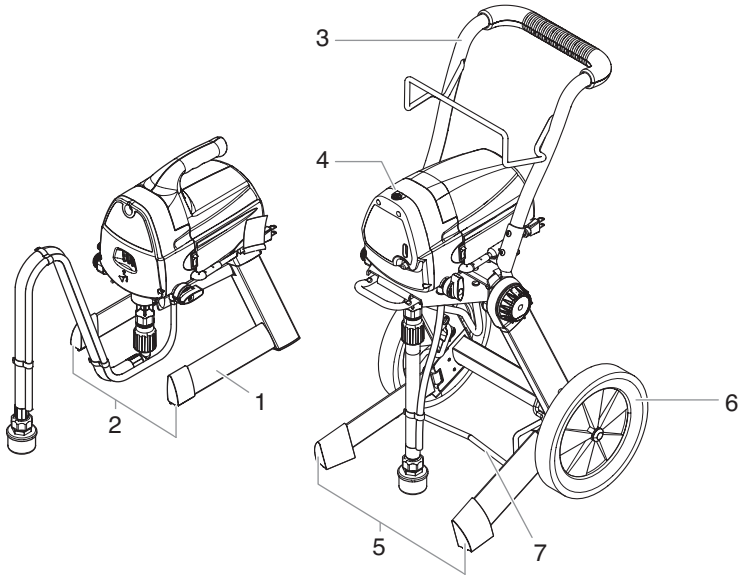

Item Art. Art.	Part No. No de pièce Pieza No.	English - Description	Français - Description	Español - Descripción	Qty. Qté. Cant.
1	0516772	Stand assembly	Ensemble de support	Ensamblaje del banco	1
2	0516773	Cap kit (100)	Trousse de capuchon (100)	Juego de tapa (100)	1
3	0516225A	Cart assembly (200)	Ensemble du chariot (200)	Ensamblaje de carrito (200)	1
4	0516581A	AutoOiler cap	Capuchon de AutoOiler	Tapa de AutoOiler	1
5	0516030	Cap kit (200)	Trousse de capuchon (200)	Juego de tapa (200)	1
6	0516465	Wheel	Roue	Rueda	1
7	0516483A	Leg lock	Verrou de pied	Seguro	1

! This unit contains no servicable parts. Do not attempt to service yourself. Store indoors with the cord wrapped around the handle.

! Cet appareil ne contient aucune pièce nécessitant un entretien quelconque. Ne tentez pas d'effectuer vous-même l'entretien. Rangez à l'intérieur d'un bâtiment avec le cordon d'alimentation enroulé autour de la poignée.

! Esta unidad no contiene piezas que se puedan reparar. No intente repararlas personalmente. Guarde la unidad en interiores con el cable enrollado alrededor de la asa.

Parts List • Liste de Pièces • Lista de Piezas

Suction set • Dispositif d'aspiration • Juego de succión

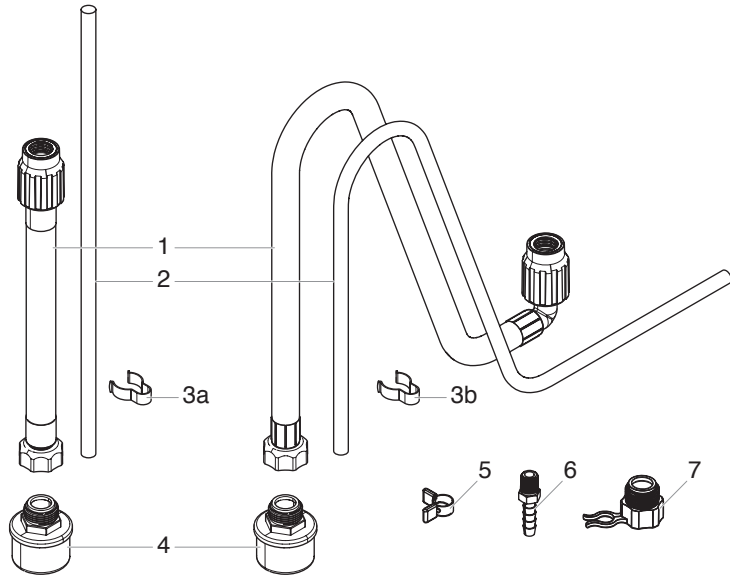

Item Art. Art.	Part No. No de pièce Pieza No.	English - Description	Français - Description	Español - Descripción	Qty. Qté. Cant.
1	0516197	Suction set (100)	Dispositif d'aspiration (100)	Juego de succión	1
	0516127	Suction set (200)	Dispositif d'aspiration (200)	Juego de succión (200)	1
2	0512371	Return tube (100)	Tube de retour (100)	Tubo de retorno (100)	1
	0512389	Return tube (200)	Tube de retour (200)	Tubo de retorno (200)	1
3a	0512390	Clip (cart models)	Agrafe (modèles du chariot)	Abrazadera (modelos de carrito)	1
3b	0512390	Clip (100)	Agrafe (100)	Abrazadera (100)	3
4	0552947	Inlet filter	Filtre d'entrée	Filtro de entrada	1
5	0327226	Squeeze clip	Agrafe de compression	Abrazadera del apretón	1
6	9885553	Return tube fitting	Raccord de tube de retour	Conector del tubo de retorno	1
7	0515146	Pump cleaning adapter	Adaptateur de nettoyage de pompe	Adaptador de limpieza de bomba	1

Parts List • Liste de Pièces • Lista de Piezas

LX-50 Spray Gun • Pistolet de LX-50 • Pistola de LX-50

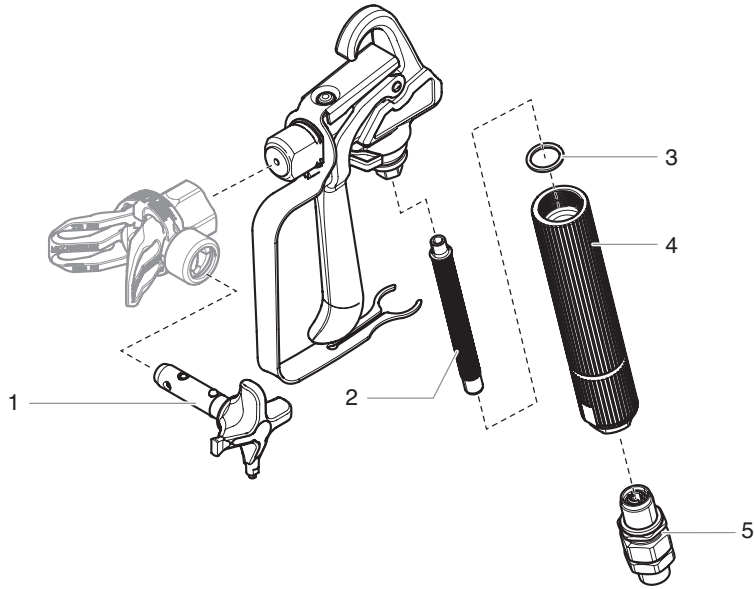

Item Art. Art.	Part No. No de pièce Pieza No.	English - Description	Français - Description	Español - Descripción	Qty. Qté. Cant.
1	692-515	TR ² tip, 515	Buse de TR ² tip, 515	Boquilla de TR ² , 515	1
2	0089959	Filter, 100 mesh (yellow, 2 pack)	Filtre, maille 100 (jaune, trousse de 2)	Filtro, malla 100 (amarillo, juego de 2)	1
3	0515228	Seal	Joint d'étanchéité	Sello	1
4	-----	Filter housing	Logement de filtre	Alojamiento de filtro	1
5	0347706A	Swivel	Raccord	Giratoria	1

Guard Assembly • Ensemble de déflecteur • Ensamblaje del protección

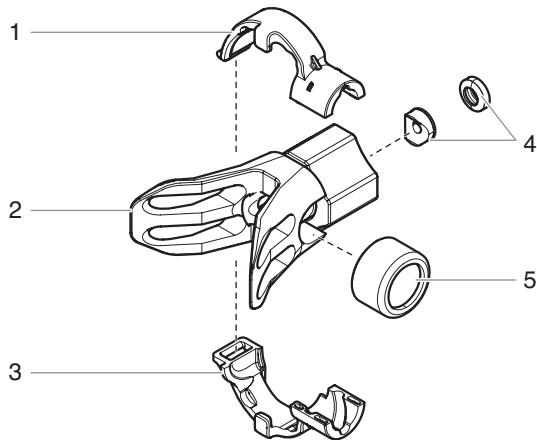

Item Art. Art.	Part No. No de pièce Pieza No.	English - Description	Français - Description	Español - Descripción	Qty. Qté. Cant.
1	0271441	Hook guide	Guide de crochet	Guía de gancho	1
2	0552945	Guard assembly	Déflecteur	Ensamblaje de protección	1
3	0271442	Latch guide	Guide de verrou	Guía de sujetador	1
4	0552946	Tip seal / saddle seat	Joint de buse / siège formé	Junta de boquilla / asiento de la montura	1
5	0296641	Collar	Collier	Collar	1
	0271065	Collar kit (includes items 1, 3 and 5)	Trousse de bague (comprendre les articles 1, 3 et 5)	Juego de collar (incluye los artículos 1, 3 y 5)	

Accessories • Accessoires • Accesorios

Part No. No de pièce Pieza No.	English - Description	Français - Description	Español - Descripción
0516701	Piston repair kit	Jeu de joints pour tronçon d'acheminement	Juego de reparación del pistón
0516713	Hose connector kit	Raccord de flexible	Conector de manguera
0552945	Tip guard	Défecteur	Ensamblaje de protección
0552946	Tip seat / seal kit	Trousse de siège / rondelle	Juego de asiento de montura / arandela
661-311	311 SC-6 spray tip	Buse de pulvérisation SC-6, 311	Boquilla rociadora SC-6, 311
661-413	413 SC-6 spray tip	Buse de pulvérisation SC-6, 413	Boquilla rociadora SC-6, 413
661-415	415 SC-6 spray tip	Buse de pulvérisation SC-6, 415	Boquilla rociadora SC-6, 415
661-515	515 SC-6 spray tip	Buse de pulvérisation SC-6, 515	Boquilla rociadora SC-6, 515
661-517	517 SC-6 spray tip	Buse de pulvérisation SC-6, 517	Boquilla rociadora SC-6, 517
692-313	313 TR ² spray tip	Buse de pulvérisation TR ² , 313	Boquilla rociadora TR ² , 313
692-515	515 TR ² spray tip	Buse de pulvérisation TR ² , 515	Boquilla rociadora TR ² , 515
692-517	517 TR ² spray tip	Buse de pulvérisation TR ² , 517	Boquilla rociadora TR ² , 517
314-482	Liquid Shield™	Liquid Shield™	Liquid Shield™
314-480	Piston Lube™ (8 oz.)	Piston Lube™ (8 oz.)	Piston Lube™ (8 oz.)
0297055	Pump Shield™ (12 oz.)	Pump Shield™ (12 oz.)	Pump Shield™ (12 oz.)
0508071	Paint Mate™ (1 qt)	Paint Mate™ (1 L)	Paint Mate™ (1 L)
0286021	LX-50 spray gun	Modèle du pistolet LX-50	Modelo de pistola rociadora LX-50
0286020	LX-65 spray gun	Modèle du pistolet LX-65	Modelo de pistola rociadora LX-65
316-513	Airless hose, 25' x 1/4"	Flexible sans air, 7,6 m x 0,6 cm	Manguera, 7,6 m x 0,6 cm
0523044	Airless hose, 35' x 1/4"	Flexible sans air, 10,6 m x 0,6 cm	Manguera, 10,6 m x 0,6 cm
316-505	Airless hose, 50' x 1/4"	Flexible sans air, 15 m x 0,6 cm	Manguera, 15 m x 0,6 cm
0516714	Hose, whip end, 5' x 1/4"	Flexible sans air, 1,5 m x 0,6 cm	Manguera, 1,5 m x 0,6 cm
0089960	Red gun filter, extra fine (2 pack)	Filtre de pistolet, rouge, très fin (2 pièces)	Filtro de pistola rojo, extra-fino (2 piezas)
0089959	Yellow gun filter, fine (2 pack)	Filtre de pistolet, jaune, fin (2 pièces)	Filtro de pistola amarillo, fino (2 piezas)
0089958	White gun filter, medium (2 pack)	Filtre de pistolet, blanc, moyen (2 pièces)	Filtro de pistola blanco, medio (2 piezas)
0516743	Tip extension, 36"	Rallonge de buse, 36 pi	Extensión de la boquilla, 36"
651-073	Tip extension, 24"	Rallonge de buse, 24 pi	Extensión de la boquilla, 24"
651-072	Tip extension, 18"	Rallonge de buse, 18 pi	Extensión de la boquilla, 18"
0516703	TR-10 telescoping roller, 3/8" nap	Rouleau télescopique de TR-10, grain de 1,0 cm	Rodillo Telescópico de TR-10, pelillo de 3/8"
0516715A	Roller cover, 3/4" nap	Manchon de rouleau, grain de 1,9 cm	Funda del rodillo, pelillo de 3/4"
0516716A	Roller cover, 3/8" nap	Manchon de rouleau, grain de 1,0 cm	Funda del rodillo, pelillo de 3/8"
0552947	Inlet filter	Filtre d'entrée	Filtro de entrada

LIMITED WARRANTY

AIRLESS PAINT SPRAY EQUIPMENT

This product, manufactured by Titan Tool, is warranted to the original retail purchaser against defects in material and workmanship for:

100 - two years from date of purchase.

200 - two years from date of purchase.

This warranty does not cover damage resulting from improper use, accidents, user's negligence or normal wear. This warranty does not cover any defects or damages caused by service or repair performed by anyone other than a Titan Authorized Service Center. This warranty does not apply to accessories.

TITAN SHALL NOT IN ANY EVENT BE LIABLE FOR ANY INCIDENTAL OR CONSEQUENTIAL DAMAGES OF ANY KIND, WHETHER FROM BREACH OF THIS WARRANTY OR ANY OTHER REASON.

If any product is defective in material and/or workmanship during the applicable warranty period, please call Titan Technical Service at 1-866-848-2698. **DO NOT RETURN THE PRODUCT TO THE ORIGINAL RETAILER.** Under Titan's Free Tool Replacement Program, Titan Technical Service will either replace the defective part, or refer you to your nearest Authorized Service Center for repair.

SOME STATES DO NOT ALLOW LIMITATIONS ON HOW LONG AN IMPLIED WARRANTY LASTS OR THE EXCLUSION OF INCIDENTAL OR CONSEQUENTIAL DAMAGES, SO THE ABOVE LIMITATION AND EXCLUSION MAY NOT APPLY TO YOU.

THIS WARRANTY GIVES YOU SPECIFIC LEGAL RIGHTS, AND YOU MAY ALSO HAVE OTHER RIGHTS WHICH VARY FROM STATE TO STATE.

GARANTIE LIMITÉE

MATÉRIEL DE PULVÉRISATION DE PEINTURE SANS AIR

Ce produit, fabriqué par Titan Tool, est garanti, au bénéfice de l'acheteur au détail d'origine, contre tout vice de matières et toute malfaçon pour:

100 - deux années à compter de la date d'achat.

200 - deux années à compter de la date d'achat.

La présente garantie ne s'applique pas aux dégâts entraînés par une utilisation incorrecte, par la négligence de l'utilisateur ou par l'usure normale. La présente garantie ne s'applique pas non plus aux défauts ou dommages résultant de l'entretien ou de la réparation que fait une personne quelconque qui ne soit pas membre d'un centre d'entretien autorisé pour les produits Titan. La présente garantie ne s'applique pas aux accessoires.

TITAN NE POURRA EN AUCUN CAS ÊTRE TENUE RESPONSABLE DE DOMMAGES-INTÉRÊTS INDIRECTS OU CONSÉCUTIFS, QUE CE SOIT POUR UNE RUPTURE DE CETTE GARANTIE OU TOUTE AUTRE RAISON.

En cas de défaut de matériau ou de fabrication du produit durant la période de garantie applicable, appelez le Service technique Titan au 1 866 848-2698. **NE RENVOYEZ PAS LE PRODUIT AU DÉTAILLANT ORIGINAL.** Dans le cadre du programme de remplacement gratuit d'outils Titan, le Service technique Titan remplacera la pièce défectueuse ou vous indiquera le centre de service agréé le plus proche.

CERTAINES PROVINCES INTERDISSENT LES RESTRICTIONS SUR LA DURÉE D'UNE GARANTIE IMPLICITE OU L'EXCLUSION DES DOMMAGES ACCESSOIRES OU INDIRECTS. IL SE PEUT DONC QUE LA RESTRICTION ET L'EXCLUSION ÉNONCÉES CI-DESSUS NE S'APPLIQUENT PAS À VOUS.

LE PRÉSENTE GARANTIE VOUS ACCORDE DES DROITS JURIDIQUES SPÉCIFIQUES, ET VOUS AVEZ PEUT-ÊTRE D'AUTRES DROITS, QUI PEUVENT VARIER D'UNE PROVINCE À L'AUTRE.

GARANTÍA LIMITADA

EQUIPO DE ATOMIZACIÓN DE PINTURA SIN AIRE

Este producto, fabricado por Titan Tool, está garantizado ante el comprador original contra defectos de materiales y mano de obra durante:

100 - dos años contado a partir de la fecha de compra.

200 - dos años contado a partir de la fecha de compra.

Esta garantía no cubre los daños que sean resultado de un uso inapropiado, accidentes, negligencia del usuario o un desgaste normal. Esta garantía no cubre ningún defecto o daño que haya sido causado por los servicios o reparaciones llevadas a cabo por alguien que no sea un técnico del Centro de Servicio Autorizado de Titan. Esta garantía no es válida para ningún accesorio.

TITAN NO SERÁ EN NINGÚN CASO RESPONSABLE DE NINGÚN DAÑO INCIDENTAL O DE CONSECUENCIA DE NINGUNA CLASE, QUE RESULTE DE VIOLAR ESTA GARANTÍA O POR CUALQUIER OTRA RAZÓN.

Si algún producto presenta fallas en los materiales y/o en su fabricación durante el periodo de vigencia de la garantía, llame al Servicio Técnico de Titan al 1-866-848-2698.

NO DEVUELVA EL PRODUCTO A LA TIENDA DONDE LO ADQUIRIÓ. Gracias al Programa de Reemplazo de Herramientas Gratis de Titan, el Servicio Técnico de Titan reemplazará la pieza defectuosa o lo derivará al Centro de Servicio Autorizado más cercano para su reparación.

ALGUNOS ESTADOS NO PERMITEN LIMITACIONES EN CUANTO A LA DURACIÓN DE UNA GARANTÍA IMPLÍCITA O LA EXCLUSIÓN DE DAÑOS INCIDENTALES O DE CONSECUENCIA, DE MANERA QUE LA LIMITACIÓN Y EXCLUSIÓN ANTERIORES PODRÍAN NO SER VÁLIDAS PARA USTED.

ESTA GARANTÍA LE CONCEDE DERECHOS LEGALES ESPECÍFICOS, PERO USTED PODRÍA TENER DERECHO A OTROS, LOS CUALES VARIAN DE UN ESTADO A OTRO.

U.S. Patent Nos.	6,981,852	6,933,634	7,018,181
	7,071,429	D550,327	D537,839
	D553,325	D550,329	D550,328
	7,458,601	D558,948	7,886,876