

WAGNER®

High-Performance Piston Pump

Owner's Manual • Notice d'utilisation • Manual del Proprietario

Quick-start

Easy does it from setup to cleanup:

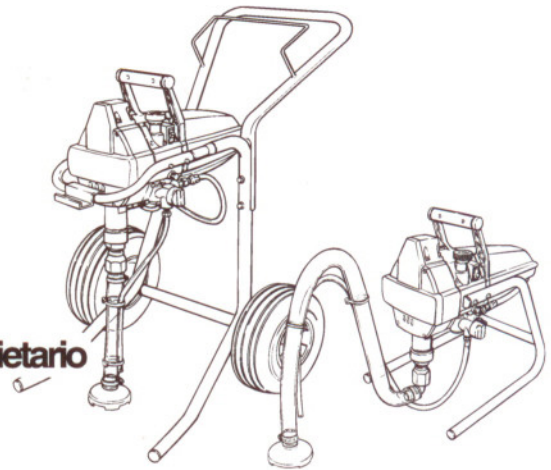

1 Read all WARNINGS!
Lire toutes les mises en garde!
¡Lea todas las advertencias!

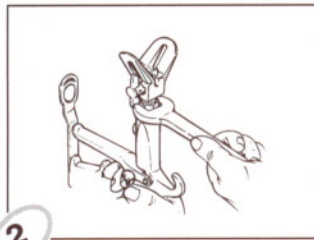

2 Attach the tip.
Attacher la tête de pulvérisation.
Fije la boquilla.

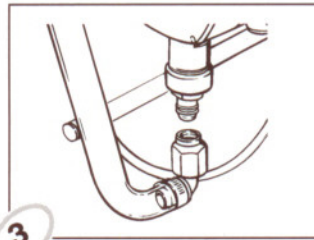

3 Attach the suction set.
Attacher l'ensemble d'aspiration.
Fije el equipo de succión.

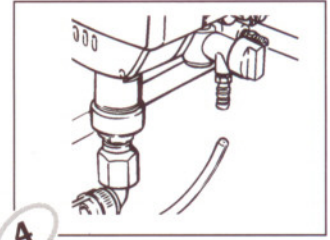

4 Attach the return hose.
Attacher le tuyau de retour.
Fije la manguera de retorno.

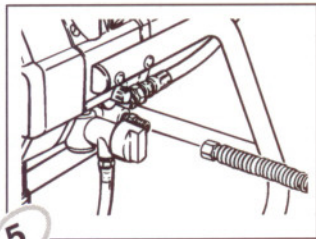

5 Attach the paint hose.
Attacher le tuyau à fluide.
Fije la manguera de fluido.

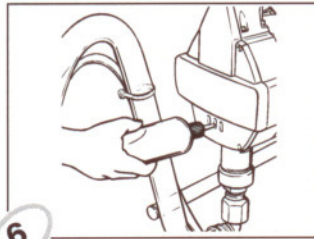

6 Lubricate the packings.
Lubrifier les garnitures.
Lubrique las empaquetaduras.

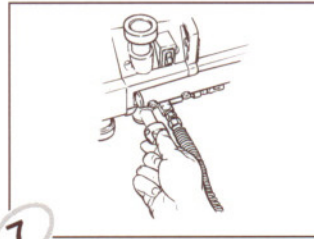

7 Purge and prime the system.
Amorcer la pompe.
Cebe la bomba.

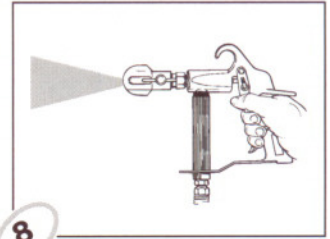

8 Spray
Pulvériser
Atomice.



9 Store temporarily
Ranger de façon temporaire
Almacene temporalmente

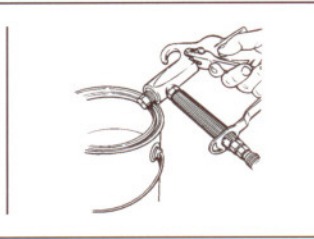

OR clean up
OU nettoyer.
O limpie.

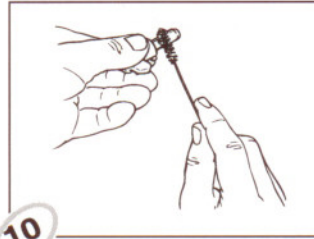

10 Maintain
Faire l'entretien.
Mantenga (De mantenimiento).

Need help? Call us first for answers fast.
Call Wagner toll-free if you have any comments
or problems with this Wagner product.



1-800-880-0993

Wagner Technical Service

Visit us on the world wide web!

<http://www.wagnerspraytech.com>

1770 Fernbrook Lane, Minneapolis, MN 55447

CONTENTS

SAFETY	2
SPECIFICATIONS	4
COMPONENTS	4
GENERAL DESCRIPTION	4
Controls and Functions	4
SETUP	5
Attaching the Handle - Cart Model Only	5
Attaching the Tip	5
Locking and Unlocking the Gun	5
Attaching the Suction Set and Return Tube	6
Attaching the Spray Hose	6
Lubricating the Packings	6
Plugging in the Unit	6
PRESSURE RELIEF PROCEDURE	6
PRIMING	6
Purging and Priming	6
SPRAYING	8
Spraying Technique	8
Practice	8
ROUTINE CLEANING	8
Unclogging the Spray Tip	8
Cleaning the Spray Tip	9
Cleaning the Suction Set Screen	9
Cleaning the Spray Gun Filter	9
CLEANUP AND STORAGE	10
Short-Term/Overnight Storage	10
Long-Term Storage	10
MAINTENANCE	12
Daily Maintenance	12
Extended Maintenance	12
ACCESSORIES	12
Choosing the Correct Spray Gun Filter	12
TROUBLESHOOTING	13
PARTS LISTING	14
FRANÇAIS	16
ESPAÑOL	30
WARRANTY	44

SAFETY

This manual contains information which must be read and understood before using the equipment. When you come to an area which has one of the following symbols, pay particular attention and make certain to heed the safeguard.



This symbol indicates a potential hazard which may cause serious injury or loss of life. Important safety information will follow.



This symbol indicates a potential hazard to you or to the equipment. Important information that tells how to prevent damage to the equipment or how to avoid causes of minor injuries will follow.

NOTE: Notes give important information which should be given special attention.

WARNING

HAZARD: INJECTION INJURY - A high pressure stream of paint produced by this equipment can pierce the skin and underlying tissues, leading to serious injury and possible amputation.

DO NOT TREAT AN INJECTION INJURY AS A SIMPLE CUT! Injection can lead to amputation. See a physician immediately.

PREVENTION:

- The maximum operating range of the unit is 2750 PSI fluid pressure.
- NEVER aim the gun at any part of the body.
- NEVER allow any part of the body to come in contact with the fluid stream. DO NOT come in contact with a fluid stream created by a leak in the fluid hose.
- NEVER put your hand in front of the gun. Gloves will not provide protection against an injection injury.
- ALWAYS lock the gun trigger, shut the fluid pump off and release all pressure before servicing, cleaning the tip guard, changing tips, or leaving unattended. Pressure will not be released by turning off the motor. The PRIME/SPRAY knob must be turned to PRIME (☉) to relieve the pressure. Refer to the PRESSURE RELIEF PROCEDURE described in this manual.
- ALWAYS have the tip guard in place while spraying. The tip guard provides some protection against injection injuries but is mainly a warning device.
- ALWAYS remove the spray tip before flushing or cleaning the system.
- The paint hose can develop leaks from wear, kinking and abuse. A leak is capable of injecting material into the skin. Inspect the paint hose before each use.
- NEVER use a spray gun which does not have a trigger lock or trigger guard in place and in working order.
- All accessories must be rated at or above 2750 PSI. This includes spray tips, guns, extensions, and hose.
- In case of a skin injection, see a physician immediately.

NOTE TO PHYSICIAN:

Injection into the skin is a traumatic injury. It is important to treat the injury surgically as soon as possible. DO NOT delay treatment to research toxicity. Toxicity is a concern with some coatings injected directly into the blood stream. Consultation with a plastic surgeon or reconstructive hand surgeon may be advisable.

HAZARD: EXPLOSION OR FIRE - Solvent and paint fumes can explode or ignite, causing property damage and/or severe injury.

PREVENTION:

- Exhaust and fresh air introduction must be provided to keep the air within the spray area free from accumulation of flammable vapors.
- Avoid all ignition sources such as static electricity sparks, open flames, pilot lights, hot objects, cigarettes, and sparks from connecting and disconnecting power cords or working light switches.
- Fire extinguishing equipment must be present and in good working order.
- Keep the unit in a well ventilated location away from the spray area to avoid solvent and paint fumes. The pump contains arcing parts which emit sparks.

- High velocity flow of material through equipment may develop static electricity. The equipment being used, as well as objects in and around the spray area, must be properly grounded to prevent static discharge and sparks.
- Use only conductive or grounded high pressure fluid hoses for airless applications. Be sure that the gun is grounded properly through hose connections.
- The power cord must be connected to a grounded circuit.
- Use extreme caution when using materials with a flashpoint below 70° F (21° C). A fluid's flashpoint is the temperature at which vapors from the fluid could ignite if exposed to a flame or spark.
- Follow the material and solvent manufacturer's safety precautions and warnings.
- When flushing equipment use the lowest possible pressure.

HAZARD: EXPLOSION HAZARD DUE TO INCOMPATIBLE MATERIALS- May cause property damage or severe injury.

PREVENTION:

- Do not use bleach.
- Do not use halogenated hydrocarbon solvents such as methylene chloride and 1,1,1 - trichloroethane. They are not compatible with aluminum and may cause an explosion. If you are unsure of a material's compatibility with aluminum, contact your coating's supplier.

HAZARD: HAZARDOUS VAPORS - Paints, solvents, insecticides, and other materials may be harmful if inhaled, causing severe nausea, fainting, or poisoning.

PREVENTION:

- Use a respirator or mask whenever there is a chance that vapors may be inhaled. Read all instructions with the mask to ensure that it will provide the necessary protection against the inhalation of harmful vapors.

HAZARD: GENERAL - May cause property damage or severe injury.

PREVENTION:

- Read all instructions and safety precautions before operating any equipment.
- Comply with all appropriate local, state, and national codes governing ventilation, fire prevention, and operation.
- The United States Government Safety Standards have been adopted under the Occupational Safety and Health Act (OSHA). These standards, particularly part 1910 of the General Standards and part 1926 of the Construction Standards should be consulted.
- This high pressure airless pump is designed to be used with manufacturer authorized parts only. When using this pump with parts that do not comply with the minimum specifications and safety devices of the pump manufacturer, the user assumes all risks and liabilities.
- Before each use, check all hoses for cuts, leaks, abrasion or bulging of cover, as well as damage or movement of couplings. If any of these conditions exist, replace the hose immediately. Never repair a paint hose. Replace it with another grounded hose.
- All hoses, swivels, guns, and accessories used with this unit must be pressure rated at or above 2750 PSI.
- Do not spray on windy days.
- Wear protective eyewear.

Grounding Instructions

This product must be grounded. In the event of an electrical short circuit, grounding reduces the risk of electric shock by providing an escape wire for the electric current. This product is equipped with a cord having a grounding wire with an appropriate grounding plug. The plug must be plugged into an outlet that is properly installed and grounded in accordance with all local codes and ordinances.



Improper installation of the grounding plug can result in a risk of electric shock.

If repair or replacement of the cord or plug is necessary, do not connect the green grounding wire to either flat blade terminal. The wire with insulation having a green outer surface with or without yellow stripes is the grounding wire and must be connected to the grounding pin.

Check with a qualified electrician or serviceman if the grounding instructions are not completely understood, or if you are in doubt as to whether the product is properly grounded. Do not modify the plug provided. If the plug will not fit the outlet, have the proper outlet installed by a qualified electrician.

This product is for use on a nominal 120 volt circuit and has a grounding plug that looks like the plug illustrated below. A temporary adapter which looks like the adapter illustrated in the figure below may be used to connect this plug to a 2 pole receptacle as shown if a properly grounded outlet is not available.

The temporary adapter should be used only until a properly grounded outlet as shown below can be installed by a qualified electrician. The green colored rigid ear lug or the grounding wire extending from the adapter must be connected to a permanent ground such as a properly grounded outlet box cover. Whenever the adapter is used, it must be held in place by a metal screw.

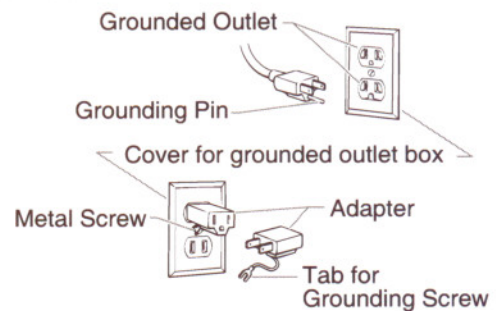

Extension Cord Selection

If an extension cord is used, make sure that it is of the 3-conductor type with NEMA connectors so a continuous grounding circuit is provided from the tool to the power circuit receptacle. Make sure your extension cord is in good condition. Also, be sure that the conductor size is large enough to prevent excessive voltage drop which will cause loss of power and possible motor damage to the unit. A 14 or 12 gauge cord is recommended.

If an extension cord is to be used outdoors, it must be marked with the suffix W-A following the cord type designation. For example, SJTW-A to indicate that it is acceptable for outdoor use.

NOTE: Do not use more than 100 feet of extension cord. If you need to paint further than 100 feet from your power source, use more paint hose, not more extension cord. Shorter extension cords will ensure maximum electrical power for proper operation.

SPECIFICATIONS

NOTE: This pump is available in two models: a stand model and a cart model. The stand model is shown in this manual. All information given for the stand model applies to the cart model except where indicated.

Weight	40 lbs. (stand model) 71 lbs. (cart model)
Capacity	Up to .35 gallon (1.33 liters) per minute. (stand model) Up to .45 gallon (1.66 liters) per minute. (cart model)
Power source	3/4 Hp permanent magnet DC motor (stand model) 1 Hp permanent magnet DC motor (cart model)
Power requirement	15 amp minimum circuit on 115 VAC, 60 Hz current.
Generator	15 amp A/C.
Spraying pressure	Up to 2750 psi.
Safety features	Spray gun trigger lock and pressure diffuser; built-in tip safety guard; priming knob for safe pressure release.
Capability	Sprays a variety of paints, oil base latex, primers, stains, preservatives and other nonabrasive materials, including pesticides and liquid fertilizers.

COMPONENTS

The shipping carton for your painting system contains the following:

- Suction set and return tube
- G-07 spray gun and filter (stand model)/G-08 spray gun and filter (cart model)
- Spray tip assembly
- 50 foot long, 1/4 inch diameter pressure hose
- Packing lubricant

GENERAL DESCRIPTION

This high performance piston pump is a precision power tool used for spraying many types of materials. Read and follow this instruction manual carefully for proper operating instructions, maintenance and safety information.

Controls and Functions

ON/OFF Switch	The ON/OFF switch turns the unit on and off.
Suction Set	Fluid is drawn through the suction set into the pump.
Fluid Section	A piston in the fluid section moves up and down to create the suction that draws fluid through the suction set.
Spray Gun	The spray gun controls the delivery of the fluid being pumped.
Spray Hose	The spray hose connects the gun to the pump.
Return Tube	Fluid is sent back out through the return tube to the original container.
PRIME/SPRAY Knob	The PRIME/SPRAY knob directs fluid to the spray hose when set to SPRAY or the return tube when set to PRIME. The \uparrow icon on the PRIME/SPRAY knob represents the SPRAY position and the \odot icon represents the PRIME position.
Pressure Control Knob	The pressure control knob controls the amount of force the pump uses to push the fluid.

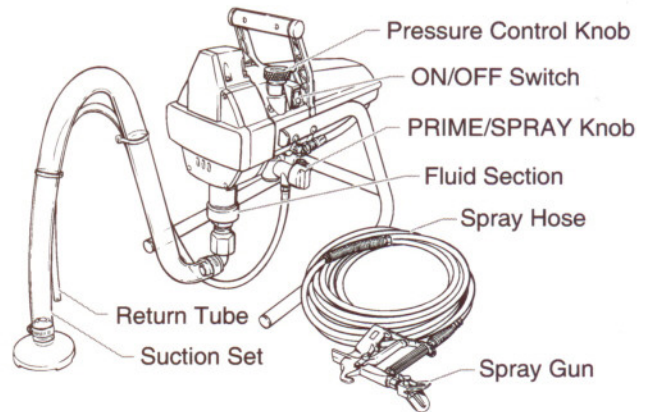

935 / 945

SPECIFICATIONS

NOTE: This pump is available in two models: a stand model and a cart model. The stand model is shown in this manual. All information given for the stand model applies to the cart model except where indicated.

Weight	45 lbs. (stand model) 76 lbs. (cart model)
Capacity	Up to .65 gallon (2.5 liters) per minute
Power source	1.1 Hp permanent magnet DC motor
Power requirement	15 amp minimum circuit on 115 VAC, 60 Hz current.
Generator	15 amp A/C.
Spraying pressure	Up to 2750 psi.
Safety features	Spray gun trigger lock and pressure diffuser; built-in tip safety guard; priming knob for safe pressure release.
Capability	Sprays a variety of paints, oil base latex, primers, stains, preservatives and other nonabrasive materials, including pesticides and liquid fertilizers.

COMPONENTS

The shipping carton for your painting system contains the following:

- Suction set and return tube
- G-08 spray gun and filter
- Spray tip assembly
- 50 foot long, 1/4 inch diameter pressure hose
- Packing lubricant

GENERAL DESCRIPTION

This high performance piston pump is a precision power tool used for spraying many types of materials. Read and follow this instruction manual carefully for proper operating instructions, maintenance and safety information.

Controls and Functions

ON/OFF Switch	The ON/OFF switch turns the unit on and off.
Suction Set	Fluid is drawn through the suction set into the pump.
Fluid Section	A piston in the fluid section moves up and down to create the suction that draws fluid through the suction set.
Spray Gun	The spray gun controls the delivery of the fluid being pumped.
Spray Hose	The spray hose connects the gun to the pump.
Return Tube	Fluid is sent back out through the return tube to the original container.
PRIME/SPRAY Knob	The PRIME/SPRAY knob directs fluid to the spray hose when set to SPRAY or the return tube when set to PRIME.
Pressure Control Knob	The pressure control knob controls the amount of force the pump uses to push the fluid.

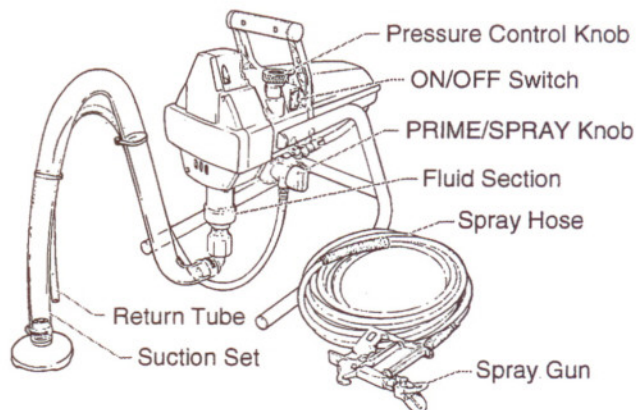

965

SETUP

⚠ WARNING

Do not plug in the unit until setup is complete.

Attaching the Handle - Cart Model Only

1. Position the handle against the cart so that the holes in the handle line up with the holes in the cart.
2. Insert the bolts through the holes in the handle and cart.
3. Tighten the nuts onto the bolts.

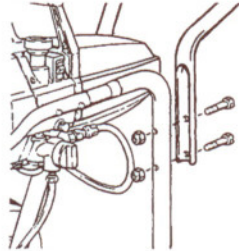

Attaching the Tip

Assembling the Tip

If the spray tip is disassembled:

1. Insert the tip into the spray guard and turn the tip to the spray position so that the arrow is facing toward the front of the spray gun.

Attaching the Tip to the Gun

1. Thread the spray tip onto the gun. Tighten the nut first by hand, then tighten more firmly with a wrench.

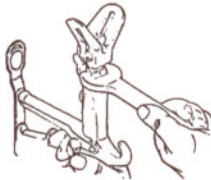

NOTE: When attaching the tip to the gun, align the tip guard as shown in the figure below, then tighten with a wrench.

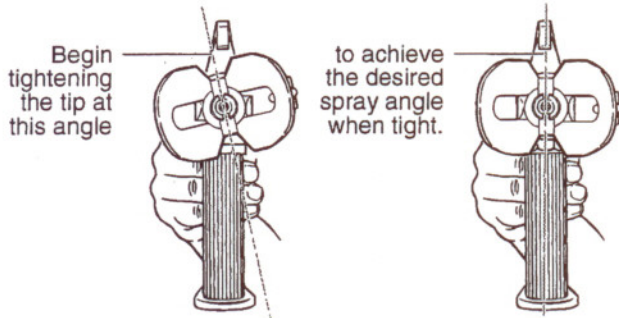

Locking and Unlocking the Gun

To lock the gun, turn the trigger lock toward the gun handle.

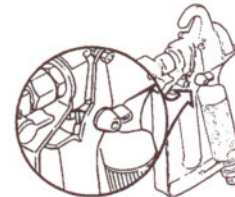

G-08 locked off
(gun will not spray)

To unlock the gun, turn the trigger lock so that it is vertical and pointing down.

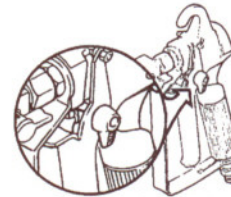

G-08 unlocked
(gun will spray)

NOTE: The trigger can be locked ON by turning the trigger lock toward the gun tip.

⚠ WARNING

POSSIBLE INJECTION HAZARD. Do not spray without the tip guard in place. Never trigger the gun unless the tip is in either the spray or the unclog position. Always engage the gun trigger lock before removing, replacing or cleaning the tip.

Attaching the Suction Set and Return Tube

1. Attach the suction set to the inlet valve and tighten firmly. On the stand model, tighten the suction set with a wrench. On the cart model, tighten the suction set by hand. Be sure that the threads are straight so that the fitting turns freely.
2. Press the return tube onto the return tube fitting.

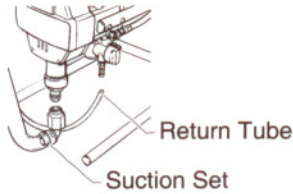

Attaching the Spray Hose

1. Attach the high pressure hose to the spray hose port. Use a wrench to tighten the spray hose securely.
2. Attach the gun to the other end of the high pressure spray hose. Tighten securely with two wrenches.

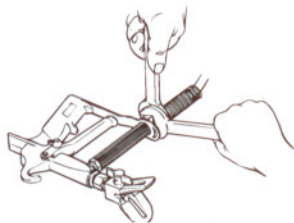
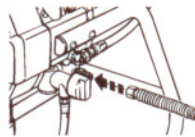

⚠ WARNING

Always lock the gun off when it is not in use.

Lubricating the Packings

Before you start to spray each day, squirt a lubricant such as hydraulic oil into the slots in the upper pump housing. Household oil and cooking oil also work when hydraulic oil is not available.

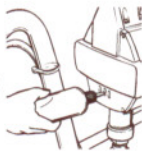

NOTE: Do not apply so much that it overflows and drips into the paint.

This lubricant keeps the piston seals pliant, minimizing paint bypass and piston wear. If the unit is operated several hours a day, lubricate approximately every 4 hours.

Plugging In the Unit

1. Check that the ON/OFF switch is in the OFF position.
2. Plug the sprayer into a properly grounded outlet or heavy duty grounded extension cord.



NOTE: Do not use more than 100 feet of cord. If you must spray a long distance from a power source, use more spray hose, not more extension cords. Use a minimum size of 16 gauge for power extension cords up to 50 feet in length, or 12 to 14 gauge for power extension cords between 50 and 100 feet in length.

PRESSURE RELIEF PROCEDURE

⚠ WARNING

Be sure to follow the pressure relief procedure when shutting the unit down for any purpose, including servicing or adjusting any part of the spray system, changing or cleaning spray tips, or preparing for cleanup.

1. Lock the spray gun off.
2. Move the ON/OFF switch to the OFF position.
3. Turn the pressure control knob fully counterclockwise to zero pressure.
4. Turn the PRIME/SPRAY knob to PRIME.
5. Be certain the spray gun is unlocked and trigger it into a container to remove any pressure which may still be in the hose.

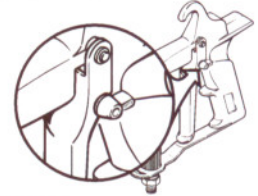

⚠ WARNING

If a metal container is used, ground the gun by holding it against the edge of the container while flushing. Failure to do so may lead to a static electric discharge which may cause a fire.



6. Lock the spray gun off.

⚠ WARNING

Injection hazard. Do not spray without the tip guard in place. NEVER trigger the gun unless the tip is completely turned to either the spray or the unclog position. ALWAYS engage the gun trigger lock before removing, replacing or cleaning the tip.

PRIMING

Purging and Priming

If this unit is new, it is shipped with test fluid in the fluid section to prevent corrosion during shipment and storage. If you are going to spray latex paint, this fluid must be purged and thoroughly cleaned out of the system. If you are going to spray with solvent-based paint, this fluid must be purged from the system, but thorough cleaning is not necessary.

If the pump has already been used you will need to purge the water or solvent used in cleanup and storage.

⚠ WARNING

Always keep the spray gun locked off while purging the pump.

Purging and Priming the Pump for Latex Paint

1. Secure the return tube into a waste container.
2. Place a bucket of soapy water under the suction tube.
3. Turn the pressure control knob fully counterclockwise to zero pressure.
4. Turn the PRIME/SPRAY valve to PRIME.

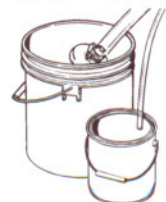

5. Move the ON/OFF switch to the ON position.

6. Slowly turn the pressure control knob clockwise to increase the pressure until fluid starts to come out of the return tube. Use only enough pressure to keep the fluid coming out.

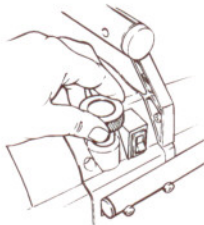

7. Turn the pressure control knob fully counterclockwise to zero pressure when the test fluid is purged and soapy water is coming out of the return tube.

8. Remove the bucket of soapy water from the suction tube and replace it with a bucket of clear water.

9. Turn the pressure control knob clockwise to increase the pressure. Use the minimum pressure necessary to keep fluid flowing until clear water is coming out of the return tube.

10. Turn the pressure control knob fully counterclockwise to zero pressure.

11. Remove the bucket of water from under the suction tube and replace it with a container of latex paint.

12. Turn the pressure control knob slowly clockwise to increase the pressure until paint is coming through the return tube.

13. Remove the return tube from the waste container and place it in its operating position above the container of paint.

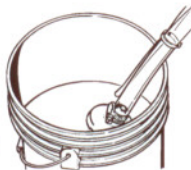

14. Keep circulating the paint through the system until the paint coming out of the return tube is free of air bubbles.

15. Turn the pressure control knob fully counterclockwise to zero pressure.

The pump is now purged. Skip to **Purging and Priming the Spray Hose**.

Purging and Priming for Solvent-Based Paint

Thorough cleaning is not necessary when using solvent-based paint. All you need to do is purge the test or storage fluid from the system.

1. Secure the return tube into a waste container.
2. Place a full container of paint under the suction tube.

3. Turn the pressure control knob fully counterclockwise to zero pressure.

4. Turn the PRIME/SPRAY valve to PRIME.

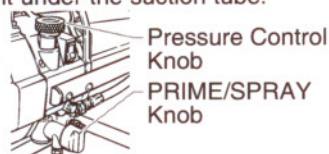

Pressure Control Knob
PRIME/SPRAY Knob

5. Move the ON/OFF switch to the ON position.

6. Slowly turn the pressure control knob clockwise to increase the pressure until fluid starts to come out of the return tube. Use only enough pressure to keep the fluid coming out.

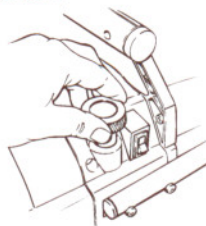

7. Turn the pressure control knob fully counterclockwise to its lowest setting when the test fluid is purged and paint is coming out of the return tube.

8. Remove the return tube from the waste container and place it in its operating position above the container of paint.

9. Keep circulating the paint through the system until the paint coming out of the return tube is free of air bubbles.

10. Turn the pressure control knob fully counterclockwise to zero pressure.

The pump is now purged. Skip to **Purging and Priming the Spray Hose**.

Purging and Priming the Spray Hose

After the pump is purged and primed, you must do the same for the spray hose.

1. Lock the spray gun off.
2. Remove the spray tip from the gun using a wrench.
3. Turn the pressure control knob fully counterclockwise to zero pressure.
4. Turn the PRIME/SPRAY knob to SPRAY.
5. Be certain that the spray gun is unlocked and trigger it into a waste container.

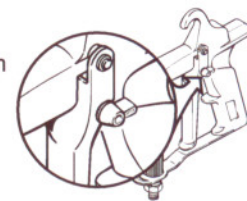

WARNING

Keep hands clear of the stream of fluid coming from the spray gun.

WARNING

If a metal container is used, ground the gun by holding it against the edge of the container while flushing. Failure to do so may lead to a static electric discharge which may cause a fire.



6. Turn the pressure control knob slowly clockwise to increase pressure and continue to trigger the gun until all air, water or solvent is purged from the spray hose and paint is flowing freely.
7. Turn the pressure control knob fully counterclockwise to zero pressure.
8. Turn the PRIME/SPRAY knob to PRIME.
9. Be certain that the spray gun is unlocked and trigger it into the waste container to be sure that no pressure is left in the hose.
10. Lock the spray gun off.
11. Attach the spray tip.

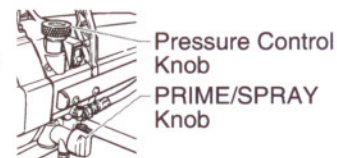

Pressure Control Knob
PRIME/SPRAY Knob

WARNING

If the pressure control knob has been turned from high to zero pressure and the PRIME/SPRAY knob is still on SPRAY, there will be high pressure in the hose and spray gun until the PRIME/SPRAY knob is turned to PRIME or until the spray gun is triggered to relieve the pressure.

SPRAYING

NOTE: Remember to lubricate the packings before starting up the pump. Follow the Lubricating the Packings procedure in this manual.

Spraying Technique

The key to a good paint job is an even coating over the entire surface. This is done by using even strokes. Keep your arm moving at a constant speed and keep the spray gun at a constant distance from the surface. The best spraying distance is 10 to 12 inches between the spray tip and the surface.

Keep the spray gun at right angles to the surface. This means moving your entire arm back and forth rather than just flexing your wrist.

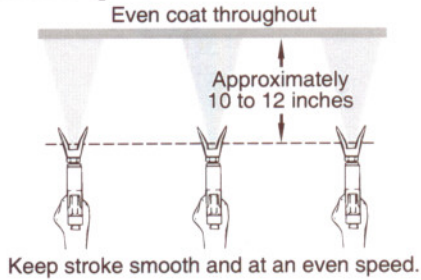

Light Coat Heavy Coat Light Coat

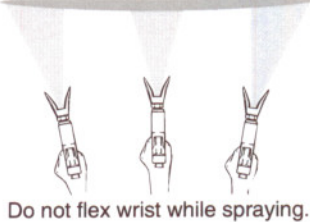

Keep the spray gun perpendicular to the surface, otherwise one end of the pattern will be thicker than the other.

The spray gun should be triggered by turning it on and off with each stroke. This will save paint and avoid paint buildup at the end of the stroke. Do not trigger the gun during the middle of a stroke. This will result in an uneven spray and splotchy coverage.

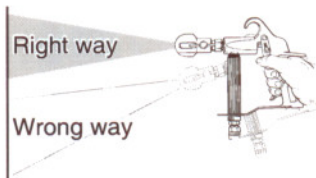

Proper way to trigger the spray gun

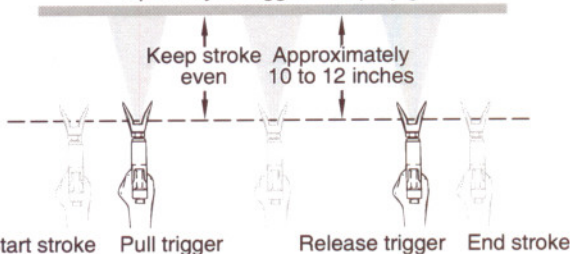

Overlap each stroke by about 30%. This will ensure an even coating.

When you stop painting, lock the gun trigger lock, turn the pressure control knob counterclockwise to zero pressure, and turn the PRIME/SPRAY knob to PRIME. Move the ON/OFF switch to OFF and unplug the unit.

If you expect to be gone more than 1 hour, follow the short-term clean up procedure described in the Clean up and Storage section of this manual.

Practice

1. Be sure that the spray hose is free of kinks and clear of objects with sharp cutting edges.
2. Turn the pressure control knob counterclockwise to zero pressure.
3. Turn the PRIME/SPRAY knob to SPRAY.
4. Turn the pressure control knob clockwise to its highest setting. The spray hose should stiffen as paint begins to flow through it.

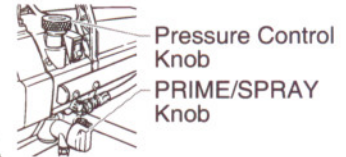

5. Be certain that the gun is unlocked and trigger it to bleed air out of the hose.
6. When paint reaches the spray tip, spray a test area to check the spray pattern.

7. Use the lowest pressure setting necessary to get a good spray pattern. If the pressure is set too high, the spray pattern will be too light. If the pressure is set too low, tailing will appear or the paint will spatter out in gobs rather than in a fine spray.

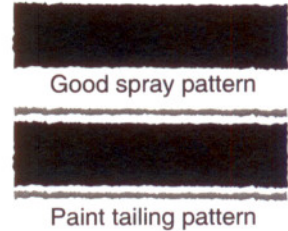

Most latex paints and stains will require very high pressure, which the sprayer is built to deliver when needed.

ROUTINE CLEANING

Unclogging the Spray Tip

WARNING

Do not attempt to unclog or clean the tip with your finger.

CAUTION

Do not use a needle or other sharp pointed instrument to clean the tip. The hard tungsten carbide is brittle and can be chipped.

The spray gun is equipped with a reversible tip which allows you to blow out any particles of old paint or other contaminants that may obstruct the paint flow through the tip. If the spray pattern becomes distorted or stops completely while the gun is triggered, follow these steps:

1. Release the trigger and lock the gun off.
2. Rotate the reversible tip cylinder arrow 180° so that the point of the arrow is toward the rear of the gun.
3. Unlock the gun and squeeze the trigger, pointing the gun at a scrap piece of wood or cardboard. This allows pressure in the spray hose to blow out the obstruction. When the nozzle is clean, paint will come out in a straight, high pressure stream.

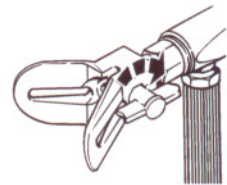

NOTE: If the spray tip remains clogged, follow the Cleaning the Spray Tip procedure.

4. Release the trigger and lock the gun off.
5. Reverse the tip so the arrow points forward again.
6. Unlock the gun and resume spraying.

Cleaning the Spray Tip

1. Turn the pressure control knob counterclockwise to zero pressure and turn the PRIME/SPRAY knob to PRIME. This will bleed off the pressure in the spray hose and filter. Trigger the gun to be sure that the pressure is gone. Refer to the PRESSURE RELIEF PROCEDURE section.
2. Lock the spray gun off.
3. Remove the spray tip assembly from the gun with a wrench.
4. Turn the spray tip so that the arrow tab is perpendicular to the spray guard and pull the tip out.
5. Push the seal, spring, and washer out the back end of the tip guard with the spray tip.
6. Wash all the tip assembly parts with soapy water or an appropriate solvent.

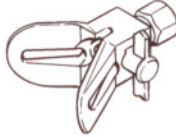

NOTE: If spraying with latex paint, use warm soapy water for cleaning. If using oil or alkyd-based paints, use mineral spirits or paint thinner. Refer to the paint manufacturer's instructions for specific recommendations.

⚠ CAUTION

Do not use mineral spirits or paint thinner on latex paint, or the mixture will turn into a jellylike substance which is difficult to remove.

7. Assemble the spray tip and attach it to the gun. Follow the Attaching the Tip procedures in this manual.
8. Apply a light coat of household oil to the sliding pins of the G-08 gun to prevent them from seizing up.



Cleaning the Suction Set Screen

The screen at the bottom of the suction set may also need cleaning. Check it every time you change paint buckets. Remove the screen by pulling it out of the retainer with a pliers. Clean the screen with water or solvent and a soft-bristle brush.



Cleaning the Spray Gun Filter

The spray gun includes a filter to catch particles before they reach the spray tip. If this filter becomes clogged or obstructed it will reduce the flow of paint, changing the spray pattern and possibly damaging the filter.

This filter must be cleaned daily. If the material being used is old or contains hardened particles, then the filter should be cleaned approximately every 4 hours.

If the filter is not cleaned at the proper time, it will plug from the top down. When there is about 1 inch of filter that isn't plugged, the heavy flow of paint will blow pin holes in the filter. Holes in the filter will allow unwanted particles to get into the spray tip, causing the spray tip to clog.

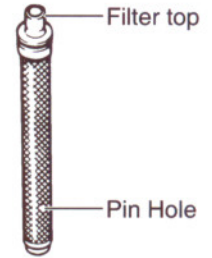

1. Turn the pressure control knob counterclockwise to zero pressure and turn the PRIME/SPRAY knob to PRIME. This will bleed off the pressure in the spray hose and filter. Trigger the gun to be sure that the pressure is gone. Refer to the PRESSURE RELIEF PROCEDURE section.
2. Lock the spray gun off.
3. Remove the spray gun from the hose using two wrenches.
4. Unclip the bottom of the knuckle guard from the filter housing on the G-08 gun by pulling outward from the filter housing.
5. Unscrew the filter housing using a wrench on the nut at the bottom of the housing.
6. Remove the filter. Do not lose the spring from the bottom of the filter housing or the washer from the top of the housing.
7. Clean the filter thoroughly or replace it with a new filter. To clean the filter, rinse it thoroughly in water or the type of solvent appropriate to the paint you are using. If this is not sufficient, use a natural or nylon bristle brush dipped in water or the appropriate solvent. Do not use a wire brush or any sharp instrument on the filter.
8. Insert the top of the filter into the gun body.
9. Place the spring into the bottom of the filter housing and the sealing washer onto the top edge of the filter housing.
10. Slide the filter housing over the filter and use a wrench to tighten it securely.
11. Clip the knuckle guard of the G-08 gun to the base of the filter housing.
12. Attach the hose to the gun. Use two wrenches to tighten it securely.
13. Turn the PRIME/SPRAY knob to SPRAY and turn the pressure control knob clockwise to increase the pressure to its previous setting.
14. Resume spraying.



CLEANUP AND STORAGE

Short-Term/Overnight Storage

Shutdown

1. Lock the spray gun off.
2. Turn the pressure control knob counterclockwise to zero pressure.
3. Turn the PRIME/SPRAY knob to PRIME.
4. Move the ON/OFF switch to the OFF position and unplug the sprayer.
5. For latex materials only, pour 1/2 cup water slowly on the top of the paint to prevent the paint from drying. For other materials, seal the paint container with a piece of plastic while the suction tube is still in the paint.

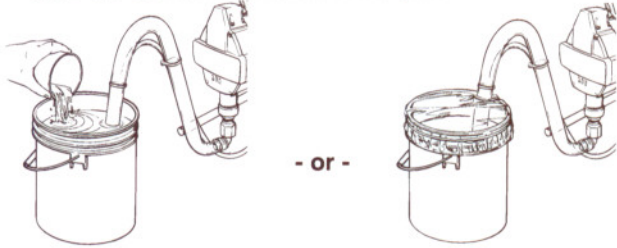

6. Wrap the spray gun assembly in a damp cloth and place it in a plastic bag. Seal the bag shut.
7. Place the sprayer in a safe place out of the sun for short-term storage.



Startup

1. Remove the gun from the plastic bag.
2. Stir the water into the paint for latex materials. Remove the seal from the paint bucket and stir the paint for all other materials.

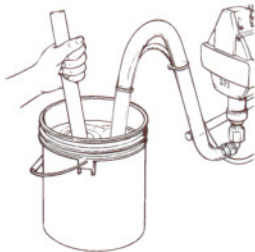

3. Check to be sure that the PRIME/SPRAY knob is set to PRIME and that the pressure is completely reduced.
4. Plug the sprayer in and turn the ON/OFF switch to ON.
5. Turn the PRIME/SPRAY knob to SPRAY and turn the pressure control knob clockwise to increase the pressure to its previous setting.
6. Test the sprayer on a practice piece and begin spraying.

Long-Term Storage

⚠ WARNING

Do not allow paint to build up on the motor or the motor will overheat. Do not allow flammable solvents to come in contact with the motor or they could ignite.

NOTE: You will need a bucket, cleaning solution, a soft brush, two wrenches and cleaning rags.

Cleaning the Suction Tube

1. Lock the spray gun off.
2. Turn the pressure control knob counterclockwise to zero pressure.
3. Turn the PRIME/SPRAY knob to PRIME.
4. Turn the ON/OFF switch to OFF and unplug the sprayer.
5. Remove the suction tube from the paint. Leave the return tube in the paint bucket.
6. Plug the sprayer in and turn the ON/OFF switch to ON.
7. Turn the pressure control knob to 1/2 maximum pressure. This will draw the remaining paint in the suction tube through the pump, down the return tube and into the paint bucket.
8. Turn the pressure control knob counterclockwise to zero pressure.
9. Be certain that the gun is unlocked and trigger it to relieve pressure.
10. Lock the spray gun off.
11. Remove the spray tip with a wrench and place it into a container of water or solvent appropriate for the type of material you are spraying.

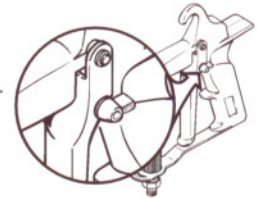

NOTE: If spraying with latex paint, use warm soapy water for cleaning. If using oil or alkyd-based paints, use mineral spirits or paint thinner. Refer to the paint manufacturer's instructions for specific recommendations.

12. Place the suction tube and return tube into a container of water or solvent appropriate for the type of material you are spraying.

⚠ CAUTION

Do not use mineral spirits or paint thinner on latex paint, or the mixture will turn into a jellylike substance which is difficult to remove.

13. Increase the pressure to 1/2 the maximum pressure. Let the water or solvent circulate for 2-3 minutes to flush paint out of the pump, the suction tube and the return tube.

Cleaning the Spray Hose

1. Make sure that the spray tip assembly has been removed from the gun and is soaking in cleaning solution.
2. Turn the pressure control knob counterclockwise to zero pressure.
3. Turn the PRIME/SPRAY knob to SPRAY.
4. To save paint left in the hose, carefully trigger the gun against the inside of the paint container.

WARNING

Keep hands clear of the stream of fluid coming from the spray gun.

WARNING

If a metal container is used, ground the gun by holding it against the edge of the container while flushing. Failure to do so may lead to a static electric discharge which may cause a fire.



5. Turn the pressure control knob slowly clockwise until paint starts to flow into the container. As soon as the water or solvent starts to come into the bucket, release the trigger.
6. Trigger the gun into the same container of cleaning solution that the suction set is in. Hold the trigger for 5 minutes to circulate the solution through the hose, pump and spray gun.
7. Turn the pressure control knob counterclockwise to zero pressure.
8. Turn the PRIME/SPRAY knob to PRIME.
9. Trigger the gun to remove any pressure which may still be in the hose.
10. Lock the gun off.
11. Move the ON/OFF switch to the OFF position.

Cleaning the Gun

1. Soak the spray tip assembly in cleaning solution for several minutes and remove.
2. Turn the spray tip so that the arrow tab is perpendicular to the spray guard and pull the tip out.
3. Push the seal, spring, and washer out the back end of the tip guard with the spray tip.
4. Disconnect the spray gun from the spray hose using two wrenches.
5. Unclip the bottom of the knuckle guard from the filter housing on the G-08 gun by pulling outward from the filter housing.
6. Unscrew the filter housing using a wrench on the nut at the bottom of the housing.
7. Remove the filter. Do not lose the spring from the bottom of the filter housing or the washer from the top of the housing.
8. Place the spray tip and filter assembly into a container of water or solvent to soak.
9. Cover the paint container and set it aside.

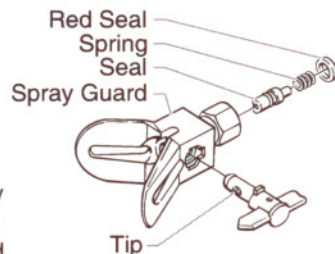

10. Clean the spray tip and gun filter with a soft brush.
11. Attach the filter housing, without the filter, to the gun using a wrench on the nut at the bottom of the housing.
12. Attach the spray hose to the gun and tighten using two wrenches.

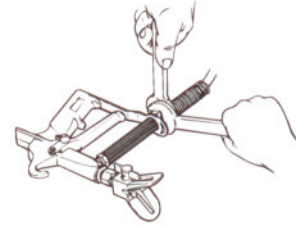

13. Turn the ON/OFF switch to ON.
14. Turn the PRIME/SPRAY knob to SPRAY.
15. Be certain that the gun is unlocked and trigger it into a container.
16. Gradually turn the pressure control knob clockwise to 1/2 pressure. Continue to trigger the gun for approximately 30 seconds.
17. Turn the pressure control knob counterclockwise to zero pressure.
18. Turn the PRIME/SPRAY knob to PRIME.
19. Trigger the gun to remove any pressure which may still be in the hose.
20. Lock the gun off.
21. Move the ON/OFF switch to the OFF position.

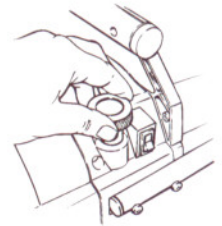

Preparing the Sprayer for Long-Term Storage

1. Check that the spray tip assembly has been removed from the gun.
2. Remove the suction set from the cleaning solution.
3. Move the ON/OFF switch to the ON position.
4. Turn the PRIME/SPRAY knob to SPRAY.
5. Turn the pressure control knob clockwise to 1/2 maximum pressure.
6. Be certain that the gun is unlocked and trigger it into the cleaning bucket until the suction set and spray hose are pumped dry.
7. Lock the gun off.
8. Turn the pressure control knob counterclockwise to zero pressure.
9. Turn the PRIME/SPRAY knob to PRIME.
10. Move the ON/OFF switch to the OFF position.
11. Remove and clean the suction set filter in clean water or the appropriate solvent. Use a soft brush. Return the suction set filter to its original position.
12. Wipe the entire unit, hose and gun with a damp cloth to remove accumulated paint.



TROUBLESHOOTING

Problem

Cause

Solution

A. The sprayer does not start.

1. The sprayer is not plugged in.
2. The ON/OFF switch is set to OFF.
3. A fuse is blown in the sprayer.
4. Low or no voltage is coming from the wall plug.
5. The sprayer was turned off while still under pressure.
6. The extension cord is damaged or has too low a capacity.
7. There is a problem with the motor.

1. Plug the sprayer in.
2. Turn the ON/OFF switch to ON.
3. Replace the blown fuse with the proper replacement.
4. Properly test the power supply voltage.
5. Turn the PRIME/SPRAY knob to PRIME.
6. Replace the extension cord.
7. Take the sprayer to a Wagner Authorized Service Center.

B. The sprayer starts but does not draw in paint when the PRIME/SPRAY knob is set to PRIME.

1. The unit will not prime properly or has lost prime.
2. The paint bucket is empty or the suction tube is not totally immersed in the paint.
3. The suction screen is clogged.
4. The suction tube is loose at the inlet valve.
5. The inlet or outlet valve is stuck.
6. The PRIME/SPRAY valve is plugged.
7. The inlet valve is worn or damaged.

1. Try to prime the unit again.
2. Refill the bucket or immerse the suction tube in paint.
3. Clean the suction set screen.
4. Clean the tube connection and tighten it securely.
5. Clean the inlet and outlet valves and replace any worn parts.*
6. Clean the PRIME/SPRAY valve and replace worn parts.*
7. Replace the inlet valve.*

C. The sprayer draws up paint but the pressure drops when the gun is triggered.

1. The spray tip is worn.
2. The suction set screen is clogged.
3. The gun or spray tip filter is plugged.
4. The paint is too heavy or coarse.
5. The outlet valve assembly is dirty or worn.
6. The inlet valve assembly is damaged or worn.

1. Replace the spray tip with a new tip.**
2. Clean the suction set screen.
3. Clean or replace the proper filter. Always keep extra filters on hand.
4. Thin or strain the paint.
5. Clean or replace the outlet valve assembly.*
6. Replace the inlet valve.*

D. The PRIME/SPRAY valve is on SPRAY and there is flow through the return tube.

1. The PRIME/SPRAY valve is dirty or worn.

1. Clean or replace the PRIME/SPRAY valve.*

E. The spray gun leaks.

1. Internal parts of the gun are worn or dirty.

1. Take the sprayer to a Wagner Authorized Service Center.

F. The tip assembly leaks.

1. The tip was assembled incorrectly.
2. A seal is worn.

1. Check the tip assembly and assemble properly.
2. Replace the seal.

G. The spray gun will not spray.

1. The spray tip, the gun filter or the tip filter is plugged.
2. The spray tip is in the CLEAN position.

1. Clean the spray tip, gun filter or tip filter.
2. Put the tip in the SPRAY position.

H. The paint pattern is tailing.

1. The pressure is set too low.
2. The gun, the tip, or the suction filter is plugged.
3. The suction tube is loose at the inlet valve.
4. The tip is worn.
5. The paint is too thick.
6. Pressure loss.

1. Increase the pressure.
2. Clean the filters.
3. Tighten the suction tube fitting.
4. Replace the spray tip.
5. Thin the paint.
6. Refer to Causes and Solutions for problem B.

NOTE: The electric motor should always be kept clean and dry. Paint acts as an insulator. Too much paint on the motor will cause the motor to overheat.

* Special repair kits with instructions are available for these procedures. Refer to the Maintenance section of this manual for a list of the kits and their part numbers.

** Additional parts are available for this procedure. Refer to the Accessories section of this manual for a list of the parts and their part numbers.

PARTS LISTING

Fluid Section

PUMP PARTS FOR 935/945

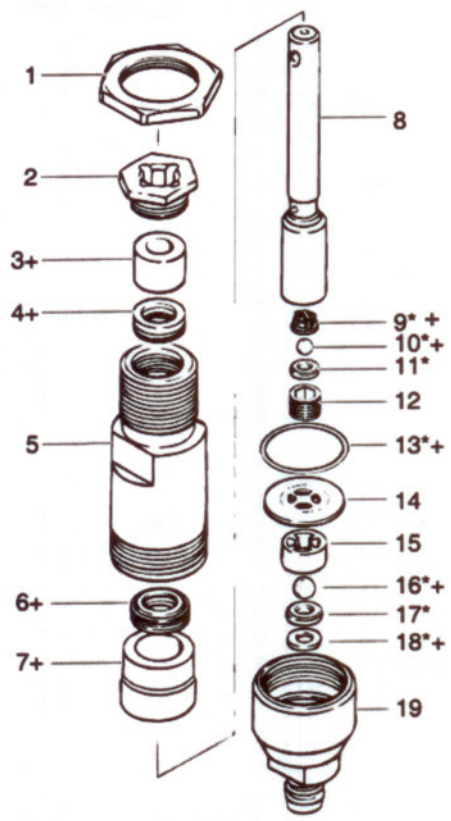

Item	Part #	Description	Quantity
1	00302	Locknut	1
2	0294319	Packing nut (torque to 25-30 ft./lbs.)	1
3		Upper spacer	1
4		Upper T-lip packing	1
5	0295305	Cylinder	1
6		Lower T-lip packing	1
7		Lower spacer	1
8	57-2602	Piston	1
9		Outlet ball guide	1
10		Outlet ball	1
11	58-2791	Outlet ball seat	1
12	12-2766	Piston seat retainer (torque to 10 ft./lbs.)	1
13		O-ring	1
14	0295304	Inlet ball stop plate	1
15	0295300	Inlet ball guide	1
16		Inlet ball	1
17	295570	Inlet ball seat	1
18		Inlet ball seal	1
19	0295314	Inlet valve housing (torque to 95-95 ft./lbs.)	1

NOTE: Valve kit P/N 0295916 includes those items marked with an *. Packing kit P/N 20-2603 includes those items marked with a +.

PARTS LISTING

Fluid Section

PUMP PARTS FOR 965

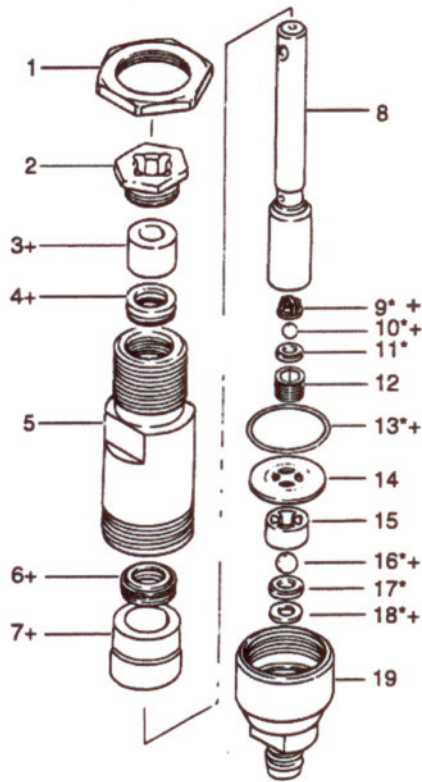

Item	Part #	Description	Quantity
1	00302	Locknut	1
2	0295361	Packing nut (torque to 25-30 ft./lbs.).....	1
3	-----	Upper spacer	1
4	-----	Upper T-lip packing.....	1
5	0295368	Cylinder.....	1
6	-----	Lower T-lip packing.....	1
7	-----	Lower spacer	1
8	57-2604	Piston.....	1
9	-----	Outlet ball guide.....	1
10	-----	Outlet ball.....	1
11	58-2791	Outlet ball seat.....	1
12	12-2766	Piston seat retainer (torque to 10 ft./lbs.)	1
13	-----	O-ring.....	1
14	295304	Inlet ball stop plate.....	1
15	0295300	Inlet ball guide	1
16	-----	Inlet ball	1
17	295570	Inlet ball seat	1
18	-----	Inlet ball seal.....	1
19	0295364	Inlet valve housing (torque to 95-95 ft./lbs.) .1	1

NOTE: Valve kit P/N 0295957 includes those items marked with an *. Packing kit P/N 20-2750 includes those items marked with a +.