

Instructions – Parts List



120 VAC, 15A

ULTRA® MAX 795 Airless Paint Sprayer

308800F

3000 psi (21 MPa, 210 bar) Maximum Working Pressure

Model 232140, Series A

Basic sprayer on upright cart without hose or gun

Model 232141, Series A

Complete sprayer on upright cart with hose, gun, RAC IV™ DripLess™ Tip Guard and SwitchTip™

U.S. PATENT No. 4,323,741; 4,397,610
PATENTED 1983, CANADA
AND OTHER PATENTS PENDING



Important Safety Instructions

Read all warnings and instructions in this manual.
Save these instructions.

Related Manuals

Displacement Pump	308798
Spray Gun	307614
Spray Tip	308644

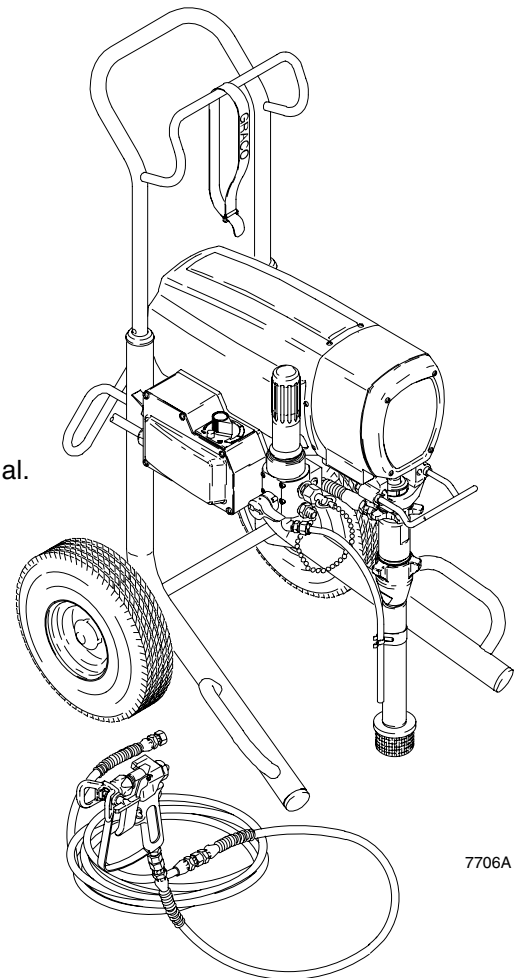

7706A

Table of Contents

Warnings	2	Bearing Housing & Connecting Rod Replacement ..	24
Component Function and Identification	5	Drive Housing Replacement	25
Setup	6	Motor Replacement	27
Startup	7	Displacement Pump Repair	29
Shutdown and Care	9	Accessories	31
Flushing	10	Technical Data	31
Troubleshooting	11	Dimensions	31
Spin Test	17	Parts Drawing – Sprayer	32
General Repair Information	16	Parts List – Sprayer	33
Motor Brush Replacement	18	Wiring Diagram	35
Power Supply Cord Replacement	19	Graco Phone Number	36
On/Off Switch Replacement	19	Graco Warranty	36
Pressure Control Repair	21		

Symbols

Warning Symbol



This symbol alerts you to the possibility of serious injury or death if you do not follow the instructions.

Caution Symbol



This symbol alerts you to the possibility of damage to or destruction of equipment if you do not follow the instructions.

! WARNING



INSTRUCTIONS

EQUIPMENT MISUSE HAZARD

Equipment misuse can cause the equipment to rupture or malfunction and result in serious injury.

- This equipment is for professional use only.
- Read all instruction manuals, tags, and labels before operating the equipment.
- Use the equipment only for its intended purpose. If you are not sure, call your Graco distributor.
- Do not alter or modify this equipment. Use only genuine Graco parts.
- Check equipment daily. Repair or replace worn or damaged parts immediately.
- Do not exceed the maximum working pressure of the lowest rated system component. Refer to the **Technical Data** on page 31 for the maximum working pressure of this equipment.
- Use fluids and solvents which are compatible with the equipment wetted parts. Refer to the **Technical Data** section of all equipment manuals. Read the fluid and solvent manufacturer's warnings.
- Do not use 1,1,1-trichloroethane, methylene chloride, other halogenated hydrocarbon solvents or fluids containing such solvents in pressurized aluminum equipment. Such use could result in a chemical reaction, with the possibility of explosion.
- Do not use hoses to pull equipment.
- Route hoses away from traffic areas, sharp edges, moving parts, and hot surfaces. Do not expose Graco hoses to temperatures above 82°C (180°F) or below -40°C (-40°F).
- Do not lift pressurized equipment.
- Comply with all applicable local, state, and national fire, electrical, and safety regulations.

WARNING



INJECTION HAZARD

Spray from the gun, leaks or ruptured components can inject fluid into your body and cause extremely serious injury, including the need for amputation. Fluid splashed in the eyes or on the skin can also cause serious injury.

- Fluid injected into the skin is a serious injury. The injury may look like just a cut, but it is a serious injury. Get immediate surgical treatment.
- Do not point the gun at anyone or at any part of the body.
- Do not put your hand or fingers over the spray tip.
- Do not stop or deflect leaks with your hand, body, glove or rag.
- Do not “blow back” fluid; this is not an air spray system.
- Always have the tip guard and the trigger guard on the gun when spraying.
- Check the gun diffuser operation weekly. Refer to the gun manual.
- Be sure the gun trigger safety operates before spraying.
- Lock the gun trigger safety when you stop spraying.
- Follow the **Pressure Relief Procedure** on page 7 if the spray tip clogs and before cleaning, checking or servicing the equipment.
- Tighten all fluid connections before operating the equipment.
- Check the hoses, tubes, and couplings daily. Replace worn or damaged parts immediately. Do not repair high pressure couplings; you must replace the entire hose.
- Fluid hoses must have spring guards on both ends, to help protect them from rupture caused by kinks or bends near the couplings.



TOXIC FLUID HAZARD

Hazardous fluid or toxic fumes can cause serious injury or death if splashed in the eyes or on the skin, inhaled, or swallowed.

- Know the specific hazards of the fluid you are using.
- Store hazardous fluid in an approved container. Dispose of hazardous fluid according to all local, state and national guidelines.
- Always wear protective eyewear, gloves, clothing and respirator as recommended by the fluid and solvent manufacturer.

! WARNING



FIRE AND EXPLOSION HAZARD

Improper grounding, poor ventilation, open flames or sparks can cause a hazardous condition and result in a fire or explosion and serious injury.

- If there is any static sparking or you feel an electric shock while using this equipment, **stop spraying immediately**. Do not use the equipment until you identify and correct the problem.
- Provide fresh air ventilation to avoid the buildup of flammable fumes from solvents or the fluid being sprayed.
- Keep the spray area free of debris, including solvent, rags, and gasoline.
- Electrically disconnect all equipment in the spray area.
- Extinguish all open flames or pilot lights in the spray area.
- Do not smoke in the spray area.
- Do not turn on or off any light switch in the spray area while operating or if fumes are present.
- Do not operate a gasoline engine in the spray area.
- Use only with a grounded outlet that matches the grounded plug of this equipment.



MOVING PARTS HAZARD

Moving parts can pinch or amputate your fingers.

- Keep clear of all moving parts when starting or operating the pump.
- Before servicing the equipment, follow the **Pressure Relief Procedure** on page 7 to prevent the equipment from starting unexpectedly.

NOTE: This is an example of the DANGER label on your sprayer. This label is available in other languages, free of charge. See page 31 to order.

! DANGER !			
	FIRE AND EXPLOSION HAZARD		SKIN INJECTION HAZARD
<p>Spray painting, flushing or cleaning equipment with flammable liquids in confined areas can result in fire or explosion.</p> <p>Use outdoors or in extremely well ventilated areas. Ground equipment, hoses, containers and objects being sprayed.</p> <p>Avoid all ignition sources such as static electricity from plastic drop cloths, open flames such as pilot lights, hot objects such as cigarettes, arcs from connecting or disconnecting power cords or turning light switches on and off.</p> <p>Failure to follow this warning can result in death or serious injury.</p>	<p>Liquids can be injected into the body by high pressure airless spray or leaks – especially hose leaks.</p> <p>Keep body clear of the nozzle. Never stop leaks with any part of the body. Drain all pressure before removing parts. Avoid accidental triggering of gun by always setting safety latch when not spraying.</p> <p>Never spray without a tip guard.</p> <p>In case of accidental skin injection, seek immediate "Surgical Treatment".</p> <p>Failure to follow this warning can result in amputation or serious injury.</p>		
READ AND UNDERSTAND ALL LABELS AND INSTRUCTION MANUALS BEFORE USE			

Component Identification and Function

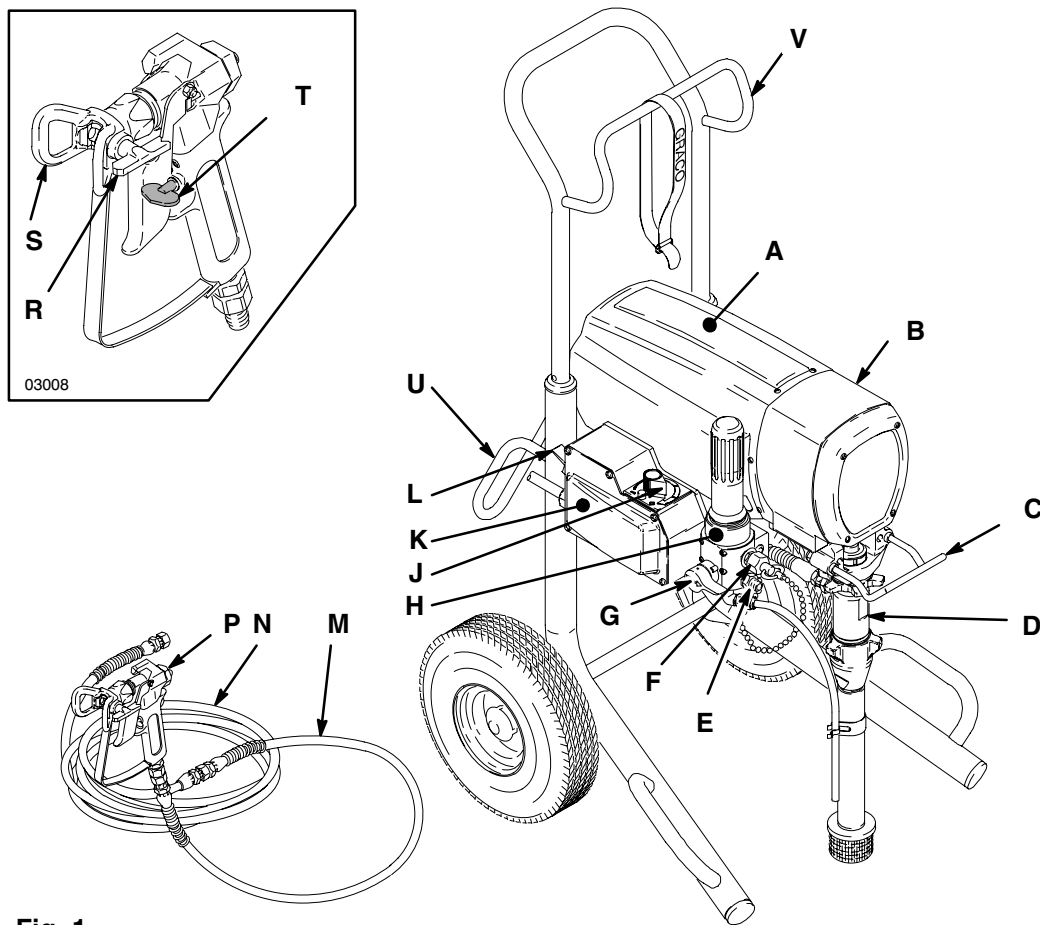

Fig. 1

7706A

A	Motor	DC motor, permanent magnet, totally enclosed, fan cooled
B	Drive Assembly	Transfers power from DC motor to the displacement pump
C	Pail Hanger	Container for fluid to be sprayed may be hung here
D	Displacement Pump	Transfers fluid to be sprayed from source through spray gun
E	Primary Fluid Outlet	Single spray gun operation is connected here
F	Secondary Fluid Outlet	Second spray gun operation is connected here
G	Pressure Drain Valve	Relieves fluid outlet pressure when open
H	Fluid Filter	Final filter of fluid between source and spray gun
J	Pressure Adjusting Knob	Controls fluid outlet pressure
K	Pressure Control	Controls motor speed to maintain fluid outlet pressure at displacement pump outlet. Works with pressure adjusting knob.
L	ON/OFF Switch	Power switch that controls 120 VAC main power to sprayer
M	3 ft (0.9 m) Hose	3/16 in. ID, grounded, nylon hose used between 50 ft hose and spray gun to allow more flexibility when spraying
N	50 ft (15 m) Main Hose	1/4 in. ID, grounded, nylon hose with spring guards on both ends
P	Contractor Gun	High pressure spray gun with gun safety latch
R	RAC IV Switch Tip	Uses high pressure fluid to clear tip clogs without removing tip from spray gun
S	RAC IV Tip Guard	Reverse-A-Clean (RAC) tip guard reduces the risk of injection injury
T	Spray Gun Safety Latch	Gun safety latch inhibits accidental triggering of spray gun
U	Power Cord Rack	Holds wrapped power cord for storage
V	Spray Hose Rack	Holds wrapped spray hose for storage

Setup

⚠ WARNING

If you supply your own hoses and spray gun, be sure the hoses are electrically conductive, that the gun has a tip guard, and that each part is rated for at least *3000 psi (210 bar, 21 MPa) Working Pressure*. This is to reduce the risk of serious injury caused by static sparking, fluid injection or over-pressurization and rupture of the hose or gun.

⚠ CAUTION

To avoid damaging the pressure control, which may result in poor equipment performance and component damage, follow these precautions:

- Do not allow material to freeze in sprayer.
- Use nylon spray hose at least 50 ft (15 m) long.
- Do not use wire braid hose.
- Do not install shutoff device between sprayer and gun. See Fig. 1.

NOTE: See Fig. 1, except where noted.

1. Fill packing nut full with Graco Throat Seal Liquid (TSL), supplied. Fig. 2.

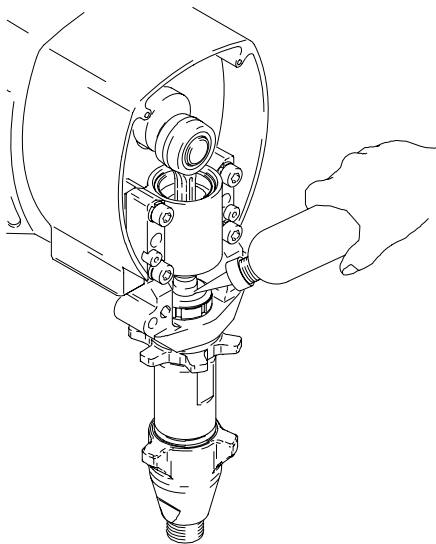

7677A

Fig. 2

2. Single gun hookup.

Use 1/4 in. ID, 50 ft (minimum) main hose. For more flexible gun movement, install 3/16 in. ID, 3 ft hose between main hose and gun.

- a. Connect gun, 3 ft hose and 50 ft hose.
- b. Connect gun and hose assembly to primary fluid outlet (F). Do not use thread sealant.
- c. Do not install spray tip.

3. Two gun hookup.

Use 1/4 in. ID, 50 ft (minimum) main hose. For more flexible gun movement, install 3/16 in. ID, 3 ft hose between main hose and gun.

- a. Connect gun, 3 ft hose and 50 ft hose.
- b. Unscrew cap from 1/4 npsm(m) secondary fluid outlet (E).
- c. Connect gun and hose assembly to secondary fluid outlet.

⚠ WARNING



FIRE AND EXPLOSION HAZARD

Proper electrical grounding is essential to reduce the risk of fire or explosion which can result in serious injury and property damage. Also read **FIRE OR EXPLOSION HAZARD** on page 4 and **Grounding**, page 7.

4. Turn ON/OFF (L) switch OFF. Plug sprayer power cord into grounded electrical outlet at least 20 ft (6 m) from spray area.
5. Flush pump to remove oil. See **Flushing**, page 10.
6. Prepare paint according to manufacturer's recommendations. Remove any paint skin. Stir paint thoroughly. Strain paint through fine nylon mesh bag (available at most paint dealers) to remove particles that could clog filter or spray tip. This is an important step for trouble-free paint spraying.

Setup

Grounding

WARNING

Improper installation or alteration of the grounding plug will result in a risk of electric shock, fire or explosion that could cause serious injury or death.

1. This equipment requires a 120 VAC, 60 Hz, 15A circuit with a grounding receptacle. See Fig. 3.

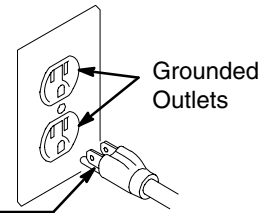

Fig. 3

2. Do not alter ground prong or use adapter.
3. A 12 AWG, 3 wires with grounding prong, 300 ft (90 m) extension cord may be used. Long lengths reduce sprayer performance.

Startup

WARNING



INJECTION HAZARD

The system pressure must be manually relieved to prevent the system from starting or spraying accidentally. Fluid under high pressure can be injected through the skin and cause serious injury. To reduce the risk of an injury from injection, splashing fluid, or moving parts, follow the **Pressure Relief Procedure** whenever you:

- are instructed to relieve the pressure,
- stop spraying,
- check or service any of the system equipment,
- or install or clean the spray tip.

Pressure Relief Procedure

1. Engage gun safety latch.
2. Turn ON/OFF switch to OFF.
3. Unplug power supply cord.
4. Disengage gun safety latch. Hold metal part of gun firmly to grounded metal pail. Trigger gun to relieve pressure.
5. Engage gun safety latch.
6. Open pressure drain valve. Leave pressure drain valve open until ready to spray again.

If you suspect that the spray tip or hose is completely clogged, or that pressure has not been fully relieved after following the steps above, VERY SLOWLY loosen tip guard retaining nut or hose end coupling to relieve pressure gradually, then loosen completely. Now clear tip or hose obstruction.

Use this procedure each time you start sprayer to ensure sprayer is ready to operate safely.

Startup Procedure

NOTE: Flush sprayer if first-time startup.
See page 10.

NOTE: See Fig. 4 except where noted.

4. Put suction tube (39) into paint container.
5. Turn pressure adjusting knob (J) fully counter-clockwise to zero pressure.
6. Plug in sprayer power cord.

CAUTION

Do not run pump without fluid in it for more than 30 seconds to avoid damaging pump packings.

WARNING



FIRE AND EXPLOSION HAZARD

To reduce risk of static sparking and splashing when priming or flushing system, hold metal part of gun firmly to side of grounded metal pail before triggering gun.

7. Prime pump.
 - a. Open (handle down) pressure drain valve (G). If no secondary hose is installed, be sure secondary outlet cap is installed. Turn ON/OFF (L) switch ON. Slowly turn pressure adjusting knob clockwise until sprayer starts. When fluid comes from drain hose, close pressure drain valve (handle forward).
 - b. Fig. 5. Disengage gun safety latch. Following warning, above, trigger gun until all air is forced out of system and paint flows freely from gun.
 - c. Release trigger. Engage gun safety latch.
8. Check all fluid connections for leaks. Relieve fluid pressure before tightening connections.
9. Fig. 5. Engage gun safety latch. Install spray tip. Install tip guard. See manual 308644, supplied.

Startup

10. Adjust spray pattern.

- a. Increase pressure just until spray from gun is completely atomized. Use lowest pressure necessary to get desired results. This reduces overspray and fogging, decreases tip wear and extends the life of the sprayer.
- b. For more coverage, use larger tip rather than increasing pressure.
- c. Test spray pattern. To adjust pattern, engage gun safety latch, loosen retaining nut. Position tip guard horizontally for horizontal pattern or vertically for vertical pattern. Then tighten retaining nut. Fig. 5.

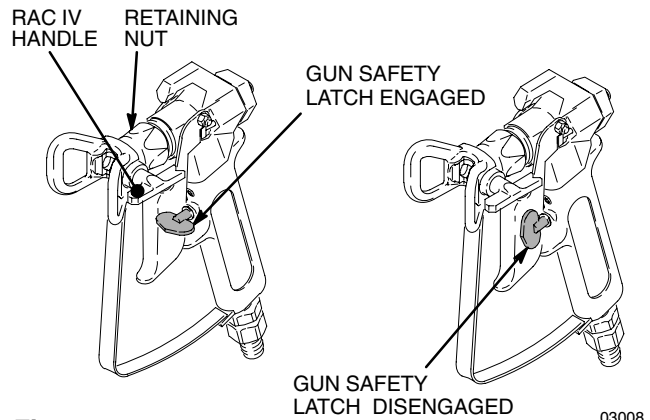
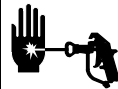

Fig. 5

03008

Cleaning a Clogged Tip

! WARNING



INJECTION HAZARD

To reduce the risk of serious injury, whenever you are instructed to relieve pressure, follow the **Pressure Relief Procedure** on page 7.

Procedure on page 7.

1. Relieve pressure.
2. Clean front of tip frequently during operation.
3. If spray tip clogs, release gun trigger, engage gun safety latch, and rotate RAC IV handle 180°. See Fig. 5.
4. Disengage gun safety latch and trigger gun into waste container. Engage gun safety latch again.
5. Rotate RAC IV handle 180° to original position, disengage gun safety latch, and resume spraying.
6. If tip is still clogged, engage gun safety latch, shut off and unplug the sprayer, and open pressure drain valve to relieve pressure. Clean spray tip as shown in manual 308644.

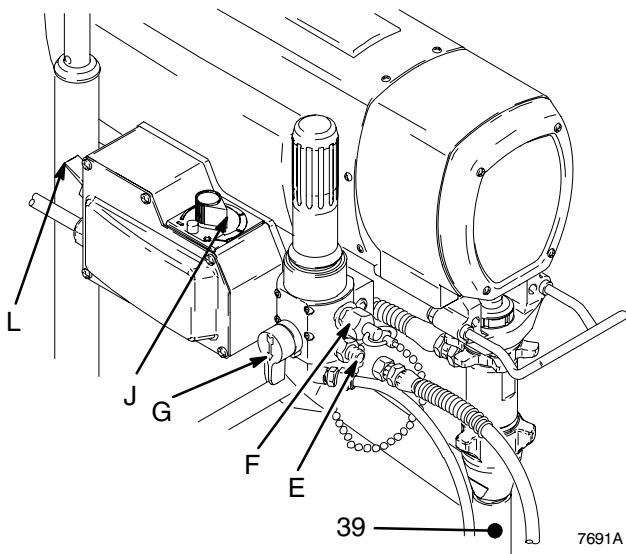

Fig. 4

Shutdown and Care

WARNING



INJECTION HAZARD

To reduce the risk of serious injury, whenever you are instructed to relieve pressure, follow the **Pressure Relief Procedure** on page 7.

Procedure on page 7.

1. Check packing nut (A) daily. First relieve pressure. Keep packing nut full of TSL at all times to help prevent fluid buildup on piston rod and premature wear of packings.

If pump begins to leak, loosen packing nut and remove throat nut spacer (228). Tighten packing nut just snug. Over tightening causes binding and excessive packing wear. Use a round punch or brass rod and light hammer to adjust nut. Refer to Fig. 6. When leakage occurs again, repack the pump.

2. Clean fluid filter often and whenever sprayer is stored. Follow Flushing Guidelines on page 10 for cleaning procedure.
3. Lubricate bearing housing after every 100 hours of operation. First relieve pressure. Remove front cover (49). Fill bearing housing cavity (B) with SAE 10 non-detergent oil. See Fig. 7.
4. For very short shutoff periods, leave suction tube in paint, relieve pressure, and clean spray tip.
5. Flush sprayer at end of each work day and fill it with mineral spirits to help prevent pump corrosion and freezing. See page 10.

CAUTION

To prevent pump corrosion, never leave water or any type of paint in the sprayer when it is not in use. Pump water or paint out with mineral spirits.

6. Coil hose and hang it on hose rack when storing it, even for overnight, to help protect hose from kinking, abrasion, coupling damage, etc.

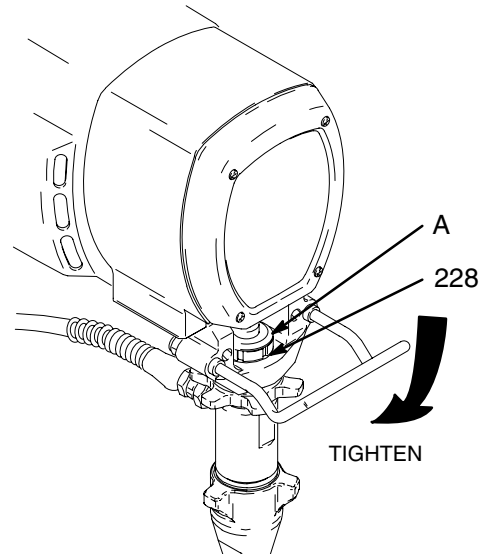

Fig. 6

7692A

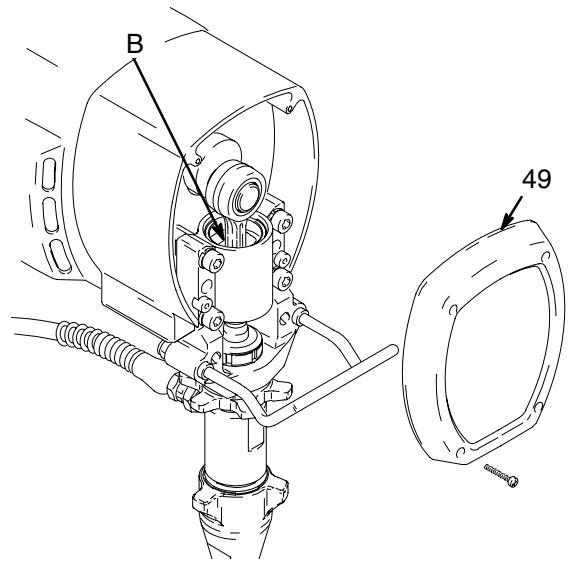

Fig. 7

7693A

Flushing

When to flush

Determine material to spray from column 1. Flush with material in column 2. Then follow recommendations in one of next three columns.

⚠ CAUTION
Do not leave water or water-based fluids in sprayer if it could freeze. Push water out with mineral spirits. Frozen fluid in sprayer prevents starting and may cause serious damage.

If you are going to: ▼	Flush with: ▼	Prime with: ▼	Clean with: ▼	Store unit with: ▼
Spray with new sprayer or sprayer that has been stored	Mineral spirits, then compatible solvent such as water or mineral spirits	Compatible paint, such as latex or oil-base	Compatible solvent such as water or mineral spirits	Mineral spirits
Spray latex paint	Warm, soapy water, then clean water	Latex paint	Warm soapy water, then clean water	Mineral spirits
Spray oil paint	Mineral spirits	Oil-base paint	Mineral spirits	Mineral spirits
Change latex to oil paint	Warm, soapy water, then clean water	Mineral spirits	Mineral spirits	Mineral spirits
Change oil to latex paint	Mineral spirits, then soapy water, and finally, clean water	Latex	Warm, soapy water, then clean water	Mineral spirits
Change colors, same base	Compatible solvent such as water or mineral spirits			

How to flush

⚠ WARNING



FIRE AND EXPLOSION HAZARD
To reduce static sparking and splashing, always remove the spray tip from the gun, and hold a metal part of the gun firmly to the side of a grounded metal pail when flushing.

1. Follow **Pressure Relief Procedure** on page 7. Engage gun safety latch.
2. Turn pressure adjusting knob (J) fully counter-clockwise to zero pressure.
3. Remove spray tip from gun. See Fig. 8. Remove filter bowl, filter support and screen. Clean screen separately and install bowl without screen or support to flush it.
4. Put suction tube into a grounded metal pail with 1/2 gallon of compatible solvent. Close pressure drain valve (G).
5. Start sprayer. See page 7. To save fluid still in sprayer, trigger gun into another container until next fluid appears, then trigger gun back into fluid compatible solvent container. Circulate flushing fluid a few minutes to thoroughly clean system.

6. Do not run pump dry for more than 30 seconds to avoid damaging pump packings!
7. Follow **Pressure Relief Procedure** on page 7. Engage gun safety latch.
8. Unscrew filter bowl and reinstall clean screen. Install bowl and hand tighten.
9. Remove suction tube and screen and clean them separately.

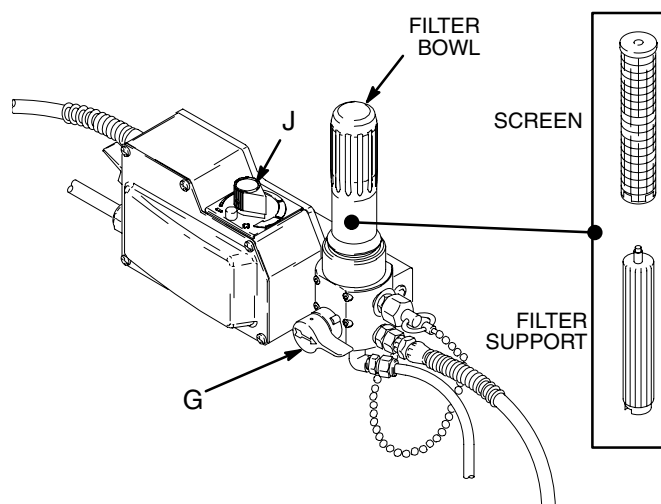

Fig. 8

7694A

Troubleshooting

⚠ WARNING



INJECTION HAZARD

To reduce the risk of serious injury, whenever you are instructed to relieve pressure, follow the **Pressure Relief Procedure** on page 7.

MOTOR WON'T OPERATE

TYPE OF PROBLEM	WHAT TO CHECK <i>If check is OK, go to next check</i>	WHAT TO DO <i>When check is not OK refer to this column</i>
Basic Fluid Pressure Problems	1. Check pressure control knob setting. The motor will not run if it is at the minimum setting (fully counterclockwise).	1. Slowly increase pressure setting to see if motor starts.
	2. Check for a clogged spray tip or fluid filter. Refer to separate gun, tip, or fluid filter instruction manual.	2. Relieve pressure, refer to separate gun, tip, or fluid filter instruction manual for cleaning.
Basic Mechanical Problems	1. Check for frozen or hardened paint in pump (64). Using a screwdriver, carefully try to rotate fan at back of motor by hand. See page 17.	1. Thaw. Plug in sprayer and turn on. Slowly increase pressure setting to see if motor starts. If it doesn't, see NOTE 1, below.
	2. Check displacement pump connecting rod pin (66). It must be completely pushed into connecting rod (63) and retaining spring (68) must be firmly in groove of connecting rod. See Fig. 25.	2. Push pin into place and secure with spring retainer.
	3. Check for motor damage. Remove drive housing assembly (67). See page 25. Try to rotate fan by hand.	3. Replace motor (73) if fan won't turn. See page 27.
Basic Electrical Problems	1. Check pressure control safety circuit.	2. Turn pressure control ON/OFF switch to OFF to RESET. If pressure control safety continues to trip, see ELECTRICAL SHORT on page 15.
	2. Check electrical supply with volt meter. Meter must read 105–125 VAC.	2. Reset building circuit breaker; replace building fuse. Try another outlet.
	3. Check extension cord for damage. Check extension cord continuity with a volt meter.	3. Replace extension cord.
	4. Check sprayer power supply cord (79) for damage such as broken insulation or wires.	4. Replace power supply cord. See page 19.

NOTE 1: Thaw sprayer if water or water-based paint has frozen in it, due to exposure to low temperatures, by placing it in a warm area. Do not try to start sprayer until it has thawed completely. If paint hardened (dried) in sprayer, pump packings must be replaced. See page 29 (**Displacement Pump Repair**).

Troubleshooting

MOTOR WON'T OPERATE (Continued)

TYPE OF PROBLEM	WHAT TO CHECK <i>If check is OK, go to next check</i>	WHAT TO DO <i>When check is not OK refer to this column</i>
Basic Electrical Problems (continued) Follow Pressure Relief Procedure on page 7. Remove gun from hose. Remove pressure control cover.	1. Check leads from motor to be sure they are securely fastened and properly mated.	1. Replace loose terminals; crimp to leads. Be sure terminals are firmly connected. Clean circuit board terminals. Securely reconnect leads.
	2. Check for loose motor brush lead connections and terminals. See page 18.	2. Tighten terminal screws. Replace brushes if leads are damaged. See page 18.
	3. Check brush length which must be 1/2 in. minimum. See page 18. NOTE: The brushes do not wear at the same rate on both sides of the motor. Check both brushes.	3. Replace brushes. See page 18.
	4. Check for broken or misaligned motor brush springs. Rolled portion of spring must rest squarely on top of brush. See page 18.	4. Replace spring if broken. Realign spring with brush. See page 18.
	5. Check motor brushes for binding in brush holders. See page 18.	5. Clean brush holders. Remove carbon with small cleaning brush. Align brush leads with slot in brush holder to assure free vertical brush movement.
	6. Check motor armature commutator for burn spots, gouges and extreme roughness. See page 18.	6. Remove motor and have motor shop resurface commutator if possible. See page 27.
	7. Check motor armature for shorts using armature tester (growler) or perform spin test. See page 17.	7. Replace motor. See page 27.
	8. Check motor control board (104) by performing motor control board diagnostics on page 21. If diagnostics indicate, substitute with a good board. CAUTION: Do not perform this check until motor armature is determined to be good. A bad motor armature can burn out a good board.	8. Replace with new pressure control board (104). See page 21.
Refer to wiring diagram on page 35 to identify test points (TP).	1. Check power supply cord (79). Connect volt meter between TP1 (neutral) and TP2. Plug in sprayer. Meter must read 105 to 125 VAC. Unplug sprayer.	1. Replace power supply cord. See page 19.
	2. Check ON/OFF switch (80). Connect volt meter between TP1 and TP3 terminal on ON/OFF switch. Plug in sprayer and turn ON. Meter must read 105 to 125 VAC. Turn off and unplug sprayer. Reconnect TP3.	2. Replace ON/OFF switch. See page 19.
	3. Check motor thermal cutoff switch. Turn sprayer OFF. Check for continuity between TP4 and TP5 with ohmmeter.	3. If thermal switch is open (no continuity), allow motor to cool. If switch remains open after motor cools, replace motor. If thermal switch closes after motor cools, correct cause of overheating.
	4. Check all terminals for damage or loose fit.	4. Replace damaged terminals and reconnect securely.

Troubleshooting

LOW OUTPUT

TYPE OF PROBLEM	WHAT TO CHECK <i>If check is OK, go to next check</i>	WHAT TO DO <i>When check is not OK refer to this column</i>
Low Output	1. Check for worn spray tip.	1. Follow Pressure Relief Procedure Warning , then replace tip. See your separate gun or tip manual.
	2. Check to see that pump does not continue to stroke when gun trigger is released. Plug in and turn on sprayer. Prime with paint. Trigger gun momentarily, then release and engage safety latch. Relieve pressure, turn off and unplug sprayer.	2. Service pump. See page 29.
	3. Check electrical supply with volt meter. Meter must read 105–125 VAC.	3. Reset building circuit breaker; replace building fuse. Repair electrical outlet or try another outlet.
	4. Check extension cord size and length; must be at least 12 gauge wire and no longer than 300 ft.	4. Replace with a correct, grounded extension cord.
	5. Check leads from motor to pressure control circuit board (104) for damaged or loose wires or connectors. Inspect wiring insulation and terminals for signs of overheating.	5. Be sure male terminal blades are centered and firmly connected to female terminals. Replace any loose terminal or damaged wiring. Securely reconnect terminals.
	6. Check for loose motor brush leads and terminals. See page 18.	6. Tighten terminal screws. Replace brushes if leads are damaged. See page 18.
	7. Check for worn motor brushes which must be 1/2 in. minimum. See page 18.	7. Replace brushes. See page 18.
	8. Check for broken and misaligned motor brush springs. Rolled portion of spring must rest squarely on top of brush.	8. Replace spring if broken. Realign spring with brush. See page 18.
	9. Check motor brushes for binding in brush holders. See page 18.	9. Clean brush holders, remove carbon dust with small cleaning brush. Align brush lead with slot in brush holder to assure free vertical brush movement.
	10. Check stall pressure.	10. Replace with new pressure control board (104). See page 21.
	11. Check motor armature for shorts by using an armature tester (growler) or perform spin test. See page 17.	12. Replace motor. See page 27.
	12. Check motor control board (104) by performing motor control board diagnostics on page 21. If diagnostics indicate, substitute with a good board. CAUTION: Do not perform this check until motor armature is determined to be good. A bad motor armature can burn out a good board.	11. Replace with new pressure control board (104). See page 21.

Troubleshooting

NO OUTPUT

TYPE OF PROBLEM	WHAT TO CHECK <i>If check is OK, go to next check</i>	WHAT TO DO <i>When check is not OK refer to this column</i>
Motor runs and pump strokes	1. Check paint supply.	1. Refill and reprime pump.
	2. Check for clogged intake strainer.	2. Remove and clean, then reinstall.
	3. Check for loose suction tube or fittings.	3. Tighten; use thread sealant or sealing tape on threads if necessary.
	4. Check to see if intake valve ball and piston ball are seating properly. See page 29.	4. Remove intake valve and clean. Check balls and seats for nicks; replace if necessary. See page 29. Strain paint before using to remove particles that could clog pump.
	5. Check for leaking around throat packing nut which may indicate worn or damaged packings. See page 29.	5. Replace packings. See pages 29–30. Also check piston valve seat for hardened paint or nicks and replace if necessary. Tighten packing nut/wet-cup.
Motor runs but pump does not stroke	1. Check displacement pump connecting rod pin (66). See page 30.	1. Replace pin if missing. Be sure retainer spring (68) is fully in groove all around connecting rod. See page 30.
	2. Check connecting rod assembly (63) for damage. See page 24.	2. Replace connecting rod assembly. See page 24.
	3. Be sure crank in drive housing rotates; plug in sprayer and turn on briefly to check. Turn off and unplug sprayer. See page 25.	3. Check drive housing assembly for damage and replace if necessary. See page 25.

EXCESSIVE PRESSURE FLUCTUATIONS

TYPE OF PROBLEM	WHAT TO CHECK <i>If check is OK, go to next check</i>	WHAT TO DO <i>When check is not OK refer to this column</i>
Spray pattern variations.	1. Be sure leads to motor control board are firmly connected. Be sure all male terminal blades are centered and firmly connected to female terminals. See Fig. 29.	1. Reconnect securely. See Fig. 29.
	2. Check maximum working pressure.	2. Replace pressure control board (104). See page 21.
	3. Check motor control board (104) by performing motor control board diagnostics on page 21. If diagnostics indicate, substitute with a good board. CAUTION: Do not perform this check until motor armature is determined to be good. A bad motor armature can burn out a good board.	3. Replace with a new pressure control board (104). See page 21.
	4. Check LOW OUTPUT section, page 13.	

Troubleshooting

MOTOR IS HOT AND RUNS INTERMITTENTLY

TYPE OF PROBLEM	WHAT TO CHECK <i>If check is OK, go to next check</i>	WHAT TO DO <i>When check is not OK refer to this column</i>
Motor is hot and runs intermittently.	1. Determine if sprayer was operated at high pressure with small tips, which causes low motor RPM and excessive heat build up.	1. Decrease pressure setting or increase tip size.
	2. Be sure ambient temperature where sprayer is located is no more than 90°F and sprayer is not located in direct sun.	2. Move sprayer to shaded, cooler area if possible.
	3. Determine if sprayer was turned on, pressurized, but not operating for long periods of time.	3. Turn off sprayer whenever you stop spraying for a while and relieve fluid pressure.

ELECTRICAL SHORT

TYPE OF PROBLEM	WHAT TO CHECK <i>If check is OK, go to next check</i>	WHAT TO DO <i>When check is not OK refer to this column</i>
Building circuit breaker opens as soon as sprayer switch is turned on. CAUTION Any short in any part of the motor power circuit will cause the control circuit to inhibit sprayer operation. Correctly diagnose and repair all shorts before checking and replacing control board.	1. Check all electrical wiring for damaged insulation, and all terminals for loose fit or damage. Also check wires between pressure control and motor. See page 27.	1. Repair or replace any damaged wiring or terminals. Securely reconnect all wires.
	2. Check for missing inspection plate gasket (see page 27), bent terminal forks or other metal to metal contact points which could cause a short.	2. Correct faulty conditions.
	3. Check motor armature for shorts. Use an armature tester (growler) or perform spin test. See page 17. Inspect windings for burns.	3. Replace motor. See page 27.
	4. Check motor control board (104) by performing motor control board diagnostics on page 21. If diagnostics indicate, substitute with a good board. CAUTION: Do not perform this check until motor armature is determined to be good. A bad motor armature can burn out a good board.	4. Replace with a new pressure control board (104). See page 21.
Building circuit breaker opens as soon as sprayer is plugged into outlet and sprayer is NOT turned on.	1. Check Basic Electrical Problems on page 11.	1. Perform necessary procedures.
	2. Check ON/OFF switch (80) See page 19. <i>Be sure sprayer is unplugged!</i> Disconnect wires from switch. Check switch with ohmmeter. The reading must be infinity with the ON/OFF switch OFF, and zero with the switch ON.	2. Replace ON/OFF switch. See page 19.
	3. Check for damaged or pinched wires in the pressure control. See page 21.	3. Replace damaged parts. See page 21.
Sprayer quits after sprayer operates for 5 to 10 minutes.	1. Check Basic Electrical Problems on page 11.	1. Perform necessary procedures.
	2. Check electrical supply with volt meter. Meter must read 105 to 125 VAC.	2. If voltage is too high, do not operate sprayer until corrected.
	3. Check tightness of pump packing nut. Over tightening tightens packings on rod, restricts pump action, and damages packings.	3. Loosen packing nut. Check for leaking around throat. Replace pump packings, if necessary. See page 29.

General Repair Information

CAUTION

To reduce the risk of a pressure control malfunction:

- Always use needle nose pliers to disconnect a wire. Never pull on the wire, pull on the connector.
- Mate wire connectors properly. Be sure flat blade of insulated male connector is centered in wrap-around blade of female connector.
- Route wires carefully to avoid interference with other connections of pressure control. Be sure wires are not pinched between cover and control box.

Tool List

Phillips screwdriver	1/4 in. hex key wrench
Small flat blade screwdriver	3/16 in. hex key wrench
Needle nose pliers	5/8 in. socket wrench
Plastic mallet or 20 oz (max) hammer	3/8 in. open end wrench
12 in. adjustable wrench	1/2 in. open end wrench
Adjustable, open-end wrench	3/4 in. open end wrench
Torque wrench	7/8 in. open end wrench
	High quality motor oil
	Bearing grease

1. **Keep all screws, nuts, washers, gaskets, and electrical fittings** removed during repair procedures. These parts are not normally provided with replacement assemblies.
2. **Test repair before regular operation** of sprayer to be sure problem is corrected.

WARNING



ELECTRIC SHOCK HAZARD

To reduce the risk of serious injury, including electric shock, **DO NOT** touch any moving parts or electrical parts with your fingers or a tool while inspecting the repair. Shut off the sprayer and unplug it as soon as you complete the inspection. Reinstall all covers, gaskets, screws and washers before operating the sprayer.

3. **If sprayer does not operate properly**, review repair procedure again to verify that everything was done correctly. If necessary, see Troubleshooting Guide, pages 11 – 15, to help identify other possible problems and solutions.

WARNING



EXPLOSION HAZARD

During operation, the motor and drive housing become very hot and could burn your skin if touched. Flammable materials spilled on the hot, bare motor could cause a fire or explosion. Always have the motor shield in place during regular operation to reduce the risk of burns, fire or explosion.

CAUTION

Do not run the sprayer dry for more than 30 seconds to avoid damaging the pump packings.

4. **Reinstall motor shield before regular operation** of sprayer and replace if damaged. The cover directs cooling air around the motor to help prevent overheating. It can also help reduce the risk of burns, fire or explosion; see preceding **WARNING**.

Spin Test

⚠ WARNING

ELECTRIC SHOCK HAZARD
Do not touch brushes, leads, springs or brush holders while the sprayer is plugged in to reduce risk of electric shock and serious bodily injury.



⚠ WARNING

INJECTION HAZARD
To reduce the risk of serious injury, whenever you are instructed to relieve pressure, follow the **Pressure Relief Procedure** on page 7.



For checking armature, motor winding and brush electrical continuity.

Setup

1. Relieve pressure. Remove drive housing. See page 25.
2. Remove motor shield (54), fan cover (A) and inspection covers (82). See Fig. 9.
3. Remove pressure control cover (B). Disconnect motor leads (F) and (G). See Fig. 10.

Armature Short Circuit Test

Relieve pressure. Quickly turn motor fan by hand. If there are no shorts, the motor will coast two or three revolutions before coming to a complete stop. If the motor does not spin freely, the armature is shorted and the motor must be replaced. See page 27.

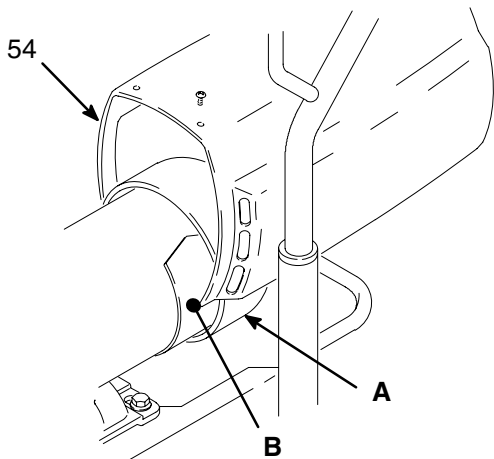

Fig. 9

7703B

Armature, Brushes, and Motor Wiring Open Circuit Test (Continuity)

1. Relieve pressure. Connect red and black motor leads together with a test lead. Turn motor fan by hand at about two revolutions per second.
2. If there is uneven or no turning resistance, check following: broken brush springs, brush leads, motor leads; loose brush terminal screws, motor lead terminals; worn brushes. Repair parts as needed. See page 18.
3. If there is still uneven or no turning resistance, replace motor. See page 27.

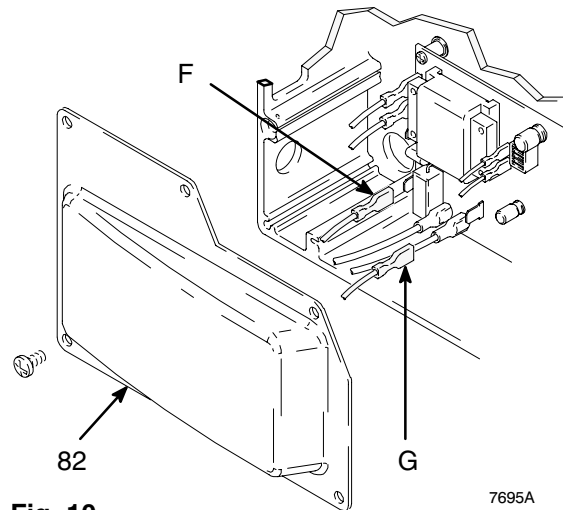

Fig. 10

7695A

Motor Brush Replacement

NOTE: Replace brushes worn to less than 1/2 in. Note that brushes wear differently on each side of motor, so check both. Brush Repair Kit 220853 is available. A new spring clip, 110816, may be purchased separately.

⚠ WARNING

INJECTION HAZARD
To reduce the risk of serious injury, whenever you are instructed to relieve pressure, follow the **Pressure Relief Procedure** on page 7.

NOTE: Read **General Repair Information** on page 16 before doing this procedure.

1. Relieve pressure.
2. Remove motor shield (54). Remove inspection covers (B) and gaskets on each side of motor. See Fig. 11.

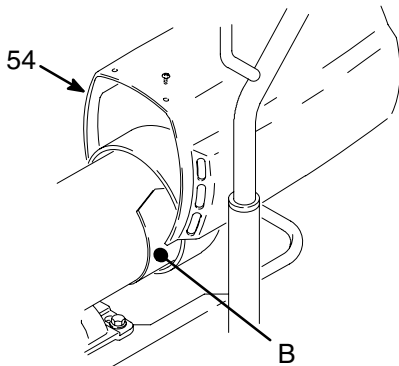

Fig. 11 7703B

3. Push in spring clip to release hooks from brush holder. Pull out spring clip. See Fig. 12.

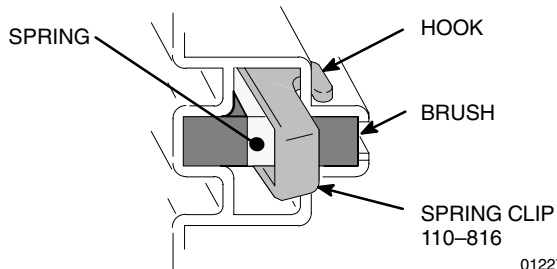

Fig. 12 01227

4. Loosen brush lead terminal screw. Pull brush lead away, leaving motor lead terminal in place. Remove brush and spring. See Fig. 14.

5. Inspect commutator for excessive pitting, burning or gouging. A black color on commutator is normal. Have commutator resurfaced by a qualified motor repair shop if brushes seem to wear too fast.

⚠ CAUTION

When installing the brushes, follow all steps carefully to avoid damaging the parts.

6. Install new brush so lead is in long slot of holder. See Fig. 13.

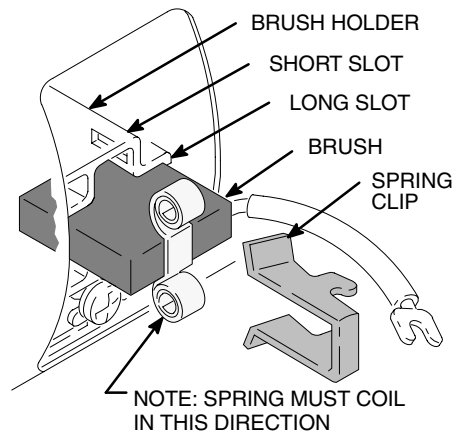

Fig. 13 01227

7. Slide terminal under terminal screw washer and tighten screw. Be sure motor lead is still connected at screw. See Fig. 14.

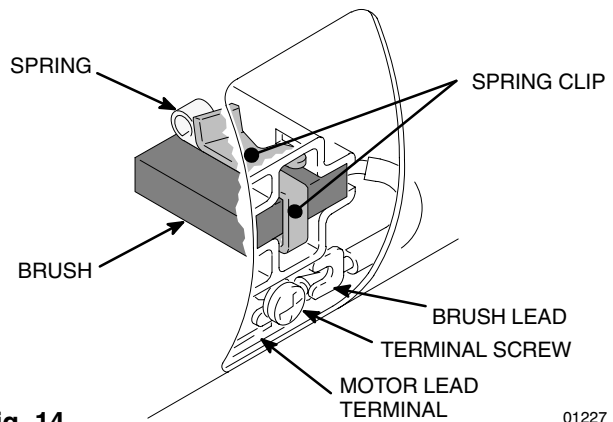



Fig. 14 01227

8. Place spring on brush as shown in Fig. 13.
9. Install spring clip and push it down to hook short slots in housing. See Fig. 13.
10. Repeat for other side.

Motor Brush Replacement

11. Test brushes.
 - a. Remove pump connecting rod pin.
 - b. With sprayer OFF, turn pressure control knob fully counterclockwise to minimum pressure. Plug in sprayer.
 - c. Turn sprayer ON. Slowly increase pressure until motor is at full speed.
 - d. Inspect brush and commutator contact area for excessive arcing. Arcs must not trail or circle around commutator surface.

⚠ WARNING



ELECTRIC SHOCK HAZARD
Do not touch brushes, leads, springs or brush holders when sprayer is plugged in to reduce risk of electric shock and serious bodily injury.

Power Supply Cord Replacement

⚠ WARNING



INJECTION HAZARD
To reduce the risk of serious injury, whenever you are instructed to relieve pressure, follow the **Pressure Relief Procedure** on page 7.

NOTE: Read **General Repair Information** on page 16 before doing this procedure. See Fig. 15.

1. Relieve pressure.
2. Remove pressure control cover (82).
3. Disconnect power supply cord black (J) lead from ON/OFF switch (80), the white wire (D) going to circuit board, and green wire (E) to grounding screw (107).
4. Loosen strain relief bushing (G) and remove power supply cord (79).
5. Install power supply cord (79) and tighten strain relief bushing (G).
6. Connect power supply cord black (J) lead to ON/OFF switch (80), white wire to circuit board (D), and green wire (E) to grounding screw (107).
7. Install pressure control cover (82).

⚠ CAUTION

Do not run the sprayer dry for more than 30 seconds while checking the brushes to avoid damaging the displacement pump packings.

12. Install brush inspection covers and gaskets.
13. Break in brushes.
 - a. Operate sprayer for one hour with no load.
 - b. Install connecting rod pin.

On/Off Switch Replacement

⚠ WARNING



INJECTION HAZARD
To reduce the risk of serious injury, whenever you are instructed to relieve pressure, follow the **Pressure Relief Procedure** on page 7.

NOTE: Read **General Repair Information** on page 16 before doing this procedure. See Fig. 15.

1. Relieve pressure.
2. Remove pressure control cover (82).
3. Disconnect two wires (B) and (J) from ON/OFF switch (80).
4. Press in on two retaining tabs on each side of ON/OFF switch (80) and remove.
5. Install new ON/OFF switch (80) so tabs of switch snap into place on inside of pressure control housing.
6. Connect two wires (B) and (J) to ON/OFF switch.
7. Install pressure control cover (82).

Power Supply Cord and On/Off Switch Replacement

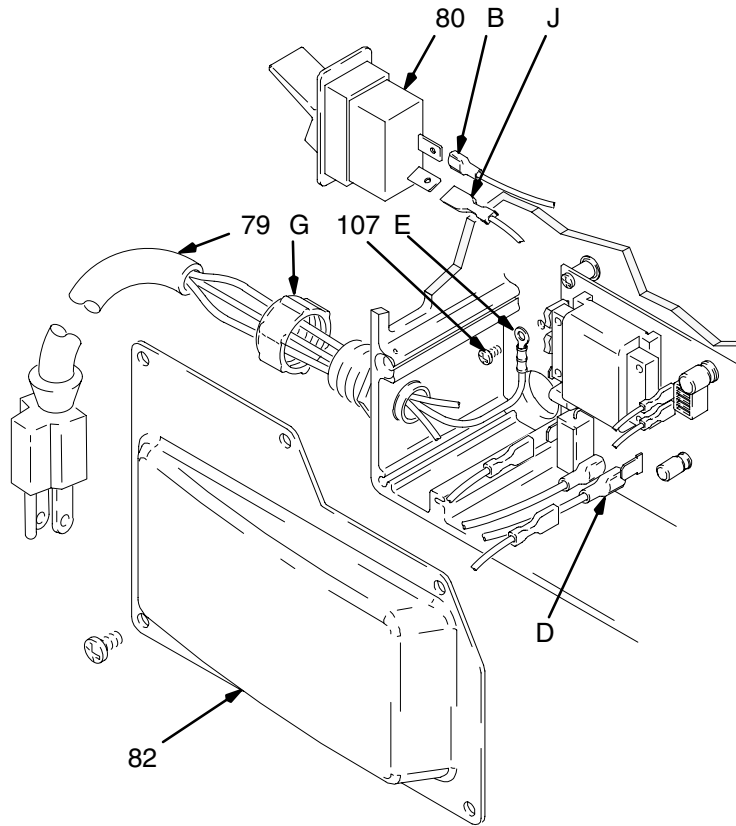



Fig. 15

7696B

Pressure Control Repair

WARNING



INJECTION HAZARD
To reduce the risk of serious injury, whenever you are instructed to relieve pressure, follow the **Pressure Relief Procedure** on page 7.

Motor Control Board Installation

1. Relieve pressure.
2. Fig. 16. Install motor control board (104) with four screws (102) and washers (103).
3. Connect to motor control board:
 - Lead (E) to transducer.
 - Lead (D) to potentiometer.
 - Lead (111) to ON/OFF switch.
 - Lead (C) to power cord.
 - Six motor leads (B).
4. Install cover (82) with five screws (28).

Motor Control Board Removal

1. Relieve pressure.
2. Fig. 16. Remove five screws (28) and cover (82).
3. Disconnect from motor control board:
 - Six motor leads (B).
 - Lead (C) from power cord.
 - Lead (111) from ON/OFF switch.
 - Lead (D) from potentiometer.
 - Lead (E) from transducer.
4. Remove four screws (102), washers (103) and circuit board (104).

Motor control board diagnostics

1. **Relieve pressure.**
2. Remove five screws (28) and cover (82). See Fig. 16.
3. Turn ON/OFF switch ON.
4. Observe LED operation and reference following table:

LED BLINKS	SPRAYER OPERATION	INDICATES	WHAT TO DO
Once	Sprayer runs	Normal operation	Do nothing
Twice	Sprayer runs	Normal operation	Do nothing
Twice repeatedly	Sprayer shuts down and LED continues to blink twice repeatedly	Line voltage is too high	Lower line voltage to 120 VAC
Three times repeatedly	Sprayer shuts down and LED continues to blink three times repeatedly	Pressure transducer is faulty or missing	Replace pressure transducer
Four times repeatedly	Sprayer shuts down and LED continues to blink four times repeatedly	Run away pressure. Pressure greater than 4500 psi.	Replace motor control board. See preceding Motor control board removal procedure.
Five times repeatedly	Sprayer shuts down and LED continues to blink five times repeatedly	Locked rotor. Motor can not turn because of some mechanical condition.	Clear obstruction and replace broken parts preventing motor from turning

Pressure Control Repair

Pressure Control Transducer Removal

1. Relieve pressure.
2. Fig. 16. Remove five screws (28) and cover (82).
3. Disconnect lead (E) from motor control board (104).
4. Remove strain relief bushing (116).
5. Remove pressure control transducer (31) and packing o-ring (59) from control housing plate (89).

Pressure Control Transducer Installation

1. Relieve pressure.
2. Fig. 16. Install packing o-ring (59) and pressure control transducer (31) in control housing plate (89). Torque to 30–35 ft-lb.
3. Install strain relief bushing (116).
4. Connect lead (E) to motor control board (104).
5. Install cover (82) with five screws (28).

Pressure Adjust Potentiometer Removal

1. Relieve pressure.
2. Fig. 16. Remove five screws (28) and cover (82).
3. Disconnect lead (D) from motor control board (104).
4. Remove potentiometer knob (81), sealing shaft nut (106) and pressure adjust potentiometer (105).

Pressure Adjust Potentiometer Installation

1. Relieve pressure.
2. Fig. 16. Install pressure adjust potentiometer (105), sealing shaft nut (106) and potentiometer knob (81).
3. Connect lead (D) to motor control board (104).
4. Install cover (82) with five screws (28).

Pressure Control Repair

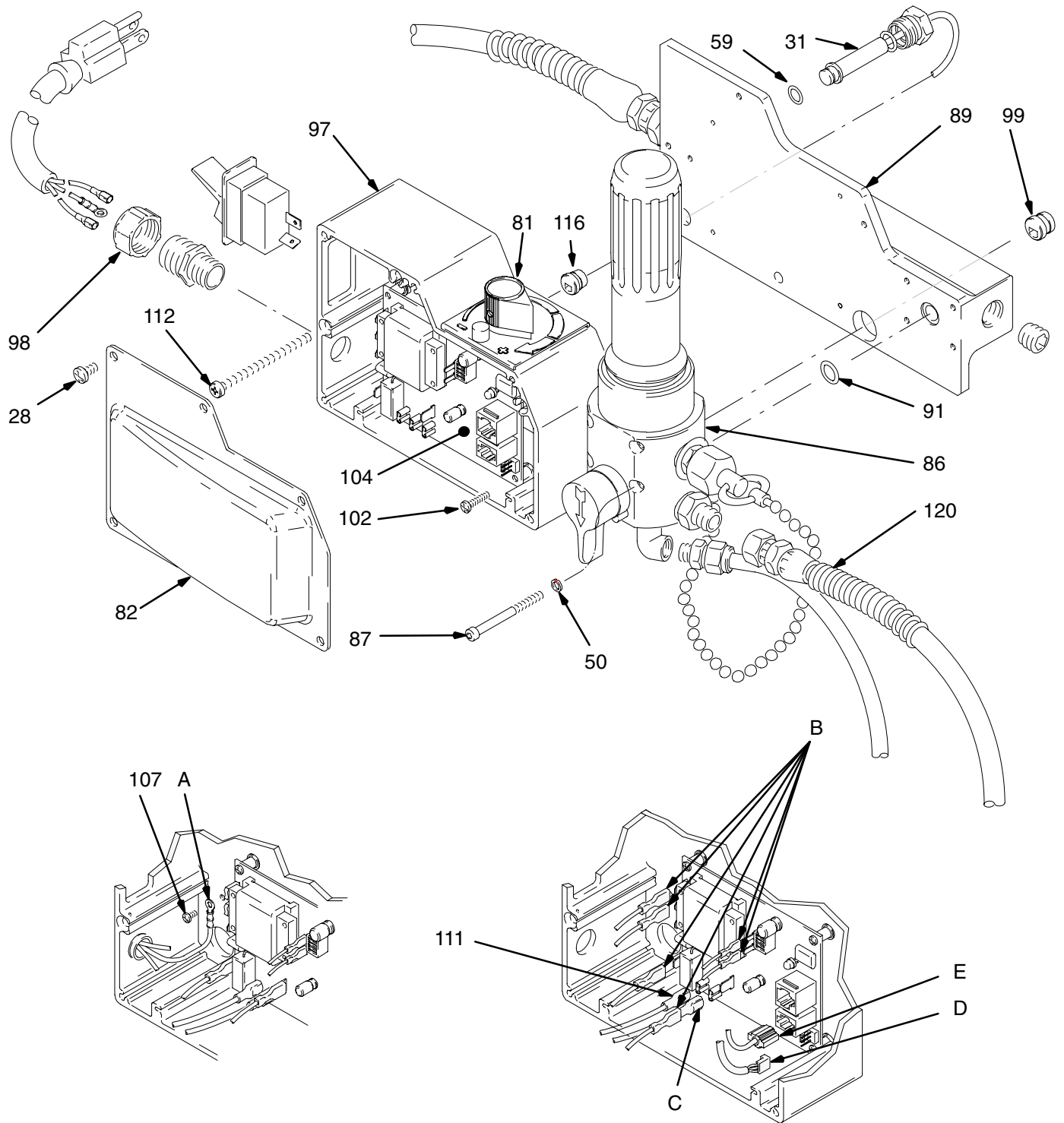

Fig. 16

7697C

Bearing Housing and Connecting Rod Replacement

⚠ WARNING



INJECTION HAZARD

To reduce the risk of serious injury, whenever you are instructed to relieve pressure, follow the **Pressure Relief Procedure** on page 7.

Procedure on page 7.

NOTE: Read **General Repair Information** on page 16 before doing this procedure. See Fig. 17.

NOTE: Stop sprayer at bottom of its stroke to get crank (E) in its lowest position. To lower crank manually, carefully rotate blades of fan with a screwdriver.

1. Relieve pressure.
2. Remove front cover (49). Unclip drain hose (36) from pump. Hold a wrench on pump intake valve (213) and unscrew pump suction tube (39). Disconnect pump hose (70).
3. Push up retaining spring (68). Push pin (66) out rear.
4. Loosen locknut (47). Unscrew displacement pump (64).
5. Remove four screws and lockwashers (25,23).
6. Lightly tap lower rear of bearing housing (22) with a plastic mallet to loosen it from drive housing (67). Pull bearing housing and connecting rod assembly (63) straight off drive housing.
7. Remove pail bracket assembly (F) and install it on new bearing housing.
8. Inspect crank (E) for excessive wear and replace parts as needed. Evenly lubricate inside of bronze bearing (B) with high quality motor oil. Liberally pack roller bearing (C) with bearing grease.
9. Assemble connecting rod (63) and bearing housing (22).
10. Clean mating surfaces of bearing and drive housings (22,67).

11. Align connecting rod (63) with crank (E) and drive housing locating pins (G) with bearing housing (22) holes. Push bearing housing onto drive housing or tap it into place with a plastic mallet.

⚠ CAUTION

DO NOT use the bearing housing screws (25) to try to align or seat the bearing housing; the bearing and drive housing will not align properly and will result in premature bearing wear.

12. Install screws and lockwashers (25,23). Tighten screws evenly to 175 in-lb (19 N.m).
13. Install pump. See page 30.
14. Install remaining parts. See Fig. 17.

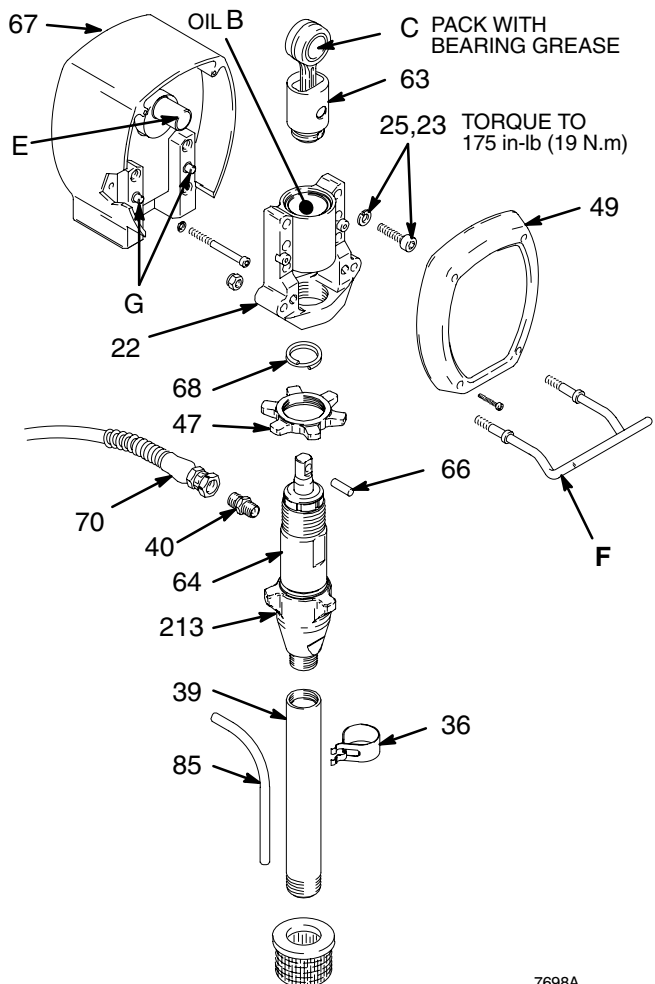

Fig. 17

7698A

Drive Housing Replacement

WARNING



INJECTION HAZARD

To reduce the risk of serious injury, whenever you are instructed to relieve pressure, follow the **Pressure Relief**

Procedure on page 7.

CAUTION

DO NOT drop gear cluster (51) when removing drive housing (67). Gear cluster may stay engaged in the motor front end bell or the drive housing.

DO NOT lose thrust balls (90) located at each end of gear cluster (51) or drop them between gears. The balls, which are heavily covered with grease, usually stay in the shaft recesses, but could be dislodged. If caught between gears and not removed, the balls will seriously damage drive housing. If the balls are not in place, the bearings will wear prematurely.

NOTE: Read **General Repair Information** on page 16 before doing this procedure. See Fig. 18.

1. Relieve pressure.
2. Remove front cover (49) and motor shield (54). Unclip drain hose (85) from pump.
3. Remove four bearing housing screws (25) and lockwashers (23).
4. Lightly tap lower rear of bearing housing (22) with a plastic mallet to loosen it from drive housing (67). Pull assembled bearing housing and connecting rod straight off drive housing.
5. Remove two drive housing screws (26) and lockwashers (20).
6. Remove two lower screws (16) and lockwashers (20) and then two upper screws (16) and lockwashers (20) from front of motor (73).
7. Tap drive housing (67) with a plastic mallet to loosen it from front of motor (73), and then pull drive housing straight off.
8. Liberally apply approximately 4 ounces of bearing grease to gear cluster (51). Grease is supplied with drive housing replacement kit. Be sure thrust balls (90) are in place.
9. Place bronze-colored washer (67b) then silver-colored washer (67a) on shaft protruding from big gear in drive housing (67).
10. Align gears and push new drive housing straight onto front of motor and locating pins.
11. Continue reassembling sprayer.

Drive Housing Replacement

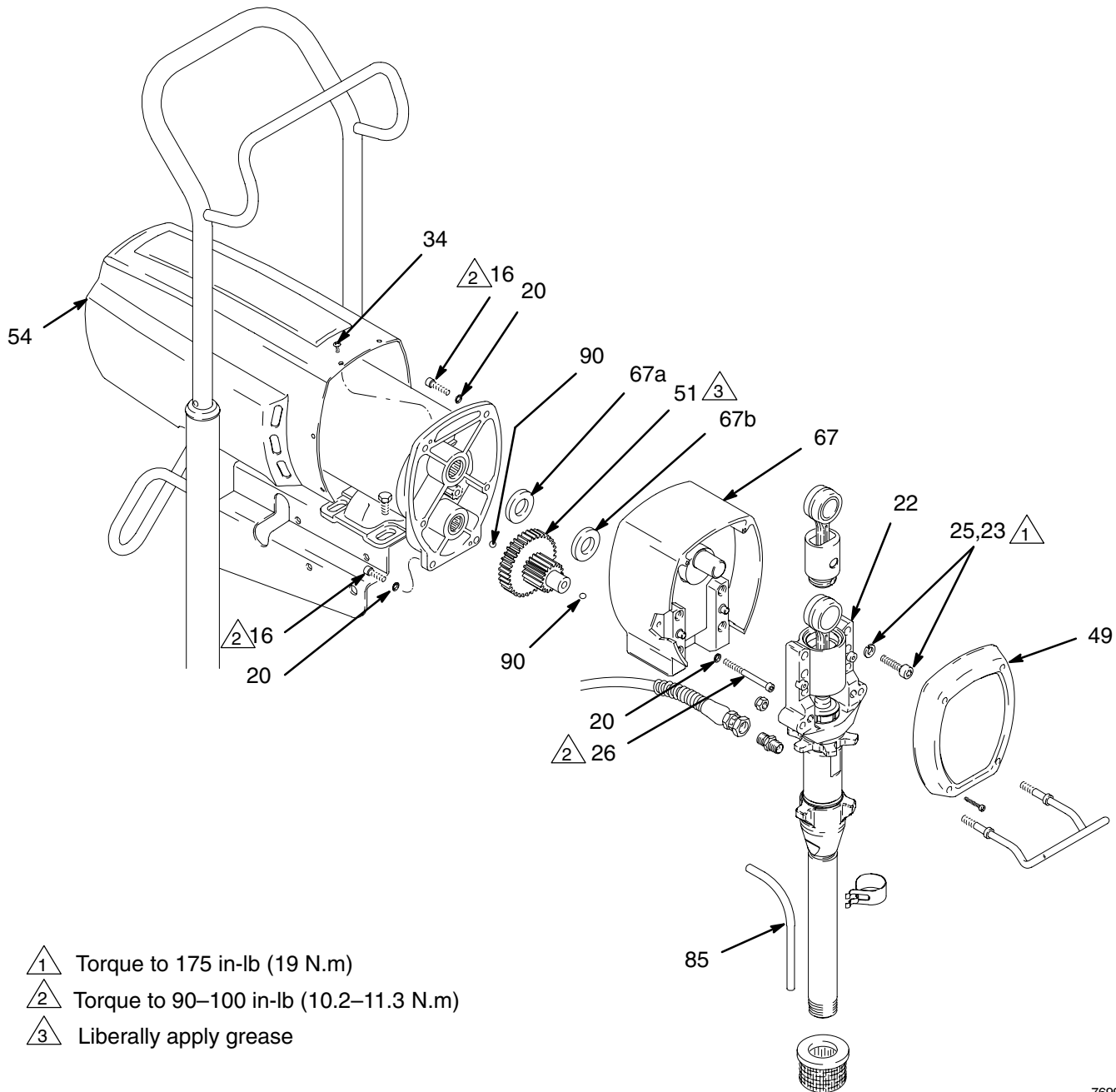

Fig. 18

7699A

Motor Replacement

WARNING



INJECTION HAZARD

To reduce the risk of serious injury, whenever you are instructed to relieve pressure, follow the **Pressure Relief Procedure** on page 7.

NOTE: Read **General Repair Information** on page 16 before doing this procedure. See Fig. 16 and 19.

1. Relieve pressure.
2. Remove motor shield (54).
3. Remove pressure control cover (82). Disconnect six motor leads (B). See figure 16.

CAUTION

Always pull the motor leads one at a time to avoid loosening the terminals, which could result in a bad connection and poor sprayer performance.

4. Remove strain relief (99) and pull motor wires bundle through pressure control opening. See figure 16.
5. Remove front cover (49).
6. Remove two drive housing screws (26).
7. Remove two lower screws (16) and lockwashers (20) and then two upper screws (16) and lockwashers (20) from front of motor (73).
8. Tap drive housing (67) with a plastic mallet to loosen it from front of motor (73), and then pull drive housing straight off.

CAUTION

DO NOT drop gear cluster (51) when removing drive housing (67). The gear cluster may stay engaged in the motor front end bell or the drive housing.

DO NOT lose thrust balls (90) located at each end of gear cluster (51) or drop them between gears. The balls, which are heavily covered with grease, usually stay in the shaft recesses, but could be dislodged. If caught between gears and not removed, the balls will seriously damage the drive housing. If the balls are not in place, the bearings will wear prematurely.

9. While supporting motor (73) to keep sprayer from tipping, remove four motor mounting screws (8). Lift off motor.
10. Install new motor (73).
11. Liberally apply approximately 4 ounces of bearing grease to gear cluster (51). Grease is supplied with drive housing replacement kit. Be sure thrust balls (90) are in place.
12. Place bronze-colored washer (67b) and then silver-colored washer (67a) on shaft protruding from big gear in drive housing (67).
13. Align gears and push drive housing (67) straight onto front of motor (73) and locating pins.
14. Continue reassembling sprayer. Feed motor wires through opening in pressure control. Connect six motor leads to pressure control printed circuit board. Install pressure control cover (A). See Fig. 16.

Motor Replacement

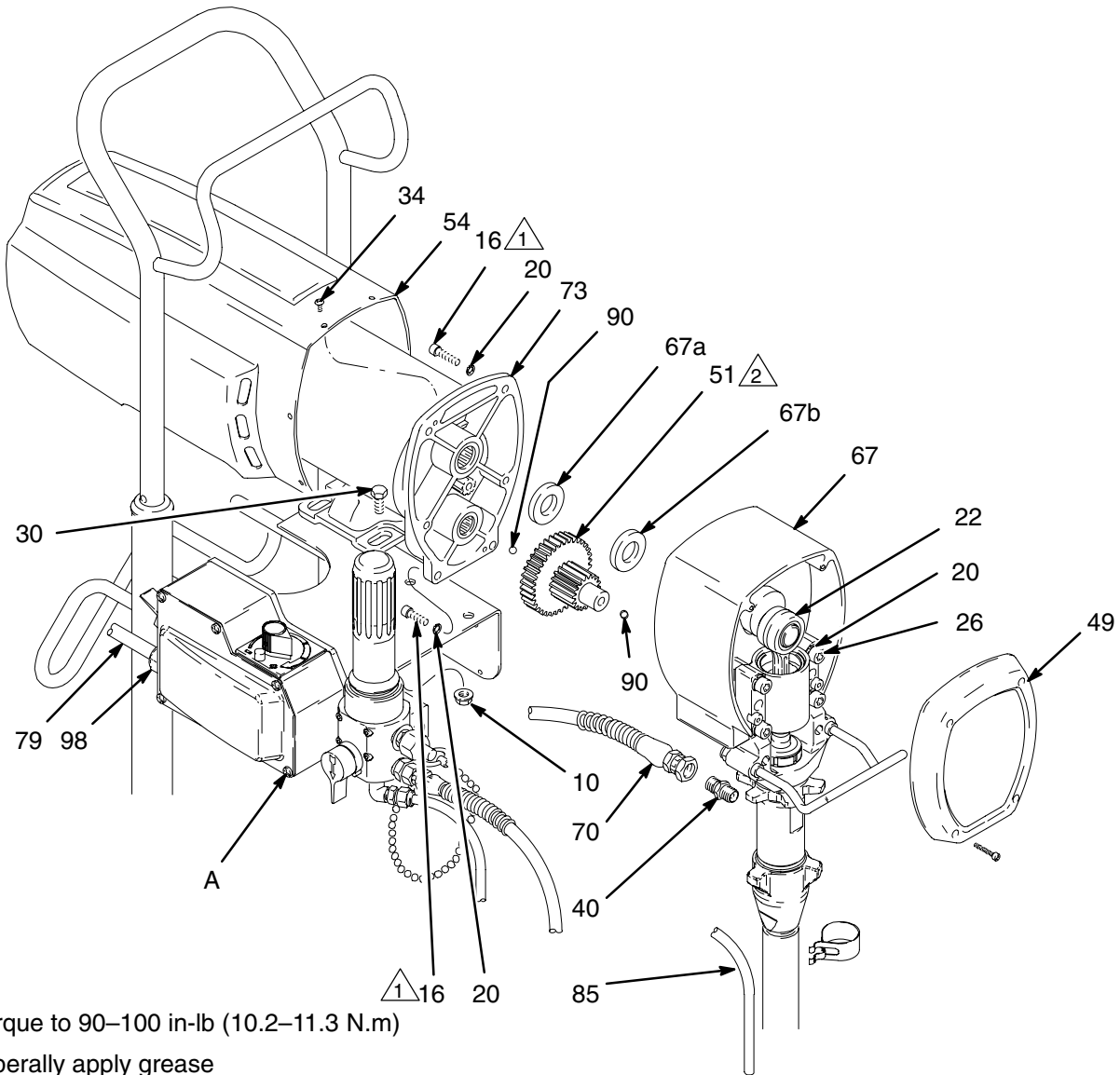

△1 Torque to 90–100 in-lb (10.2–11.3 N.m)

△2 Liberally apply grease

Fig. 19

7700B

Displacement Pump Repair

Removing pump

1. Flush pump. Relieve pressure. Fig. 20. Cycle pump with piston rod (222) in its lowest position.
2. Fig. 20. Unscrew suction tube and hose from pump.

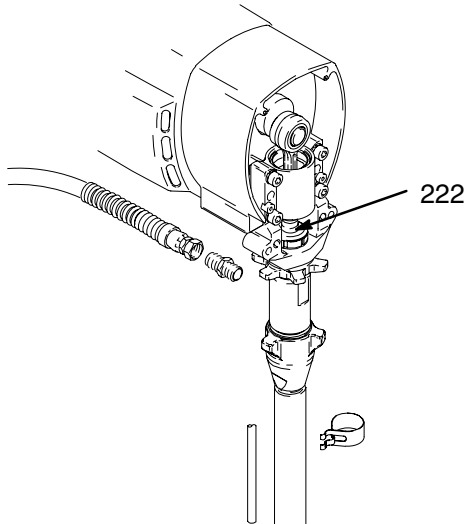

Fig. 20 _____ 7672A

3. Fig. 21. Use screwdriver to push retaining spring up.

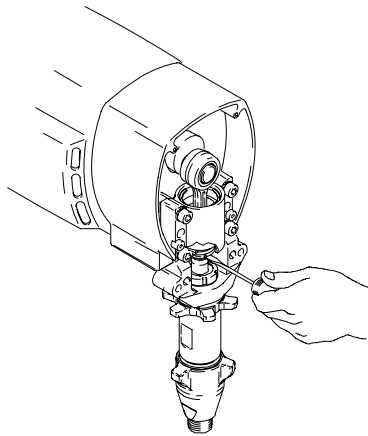

Fig. 21 _____ 7674A

4. Fig. 22. Push out pin.

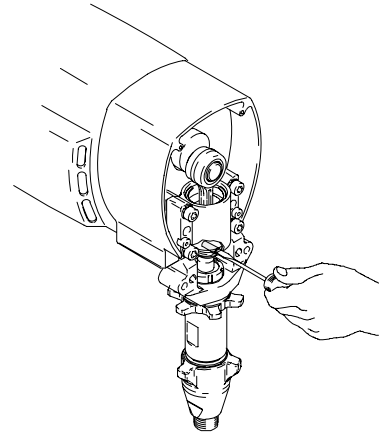

Fig. 22 _____ 7675A

5. Fig. 23. Loosen locknut by hitting firmly with a 20 oz (maximum) hammer. Unscrew pump.

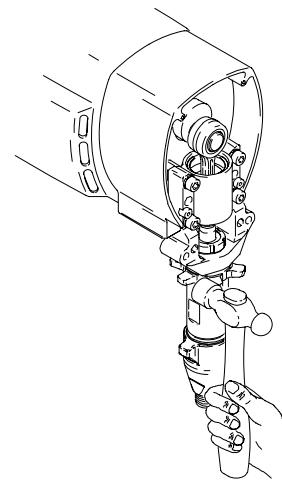

Fig. 23 _____ 7673A

Repairing Pump

See manual 308798 for pump repair instructions.

Displacement Pump Repair

Installing pump

⚠ WARNING

If the pin works loose, it or other parts could break off due to the force of the pumping action. These parts could be projected through the air and result in serious bodily injury or property damage, including damage to the pump, connecting rod or bearing housing.

⚠ CAUTION

If the pump locknut loosens during operation, the threads of the bearing housing will be damaged.

1. Fig. 24. Pull piston rod out 1.5 in. Screw in pump until holes in bearing cross link and piston rod align.

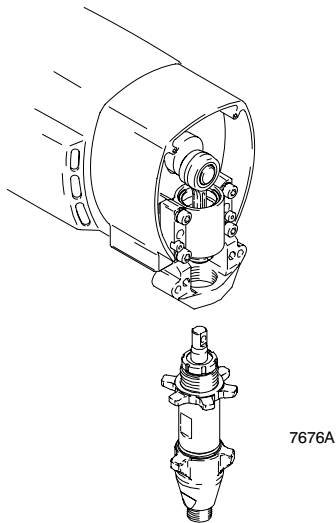

Fig. 24

2. Fig. 25. Push pin (21) into holes.

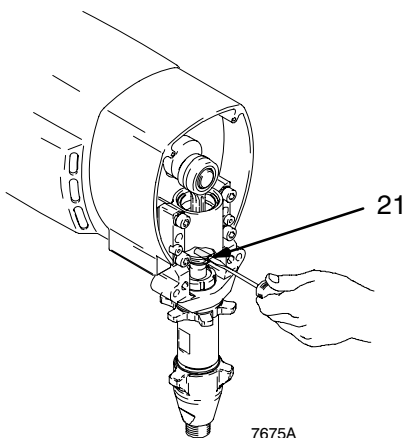

Fig. 25

3. Fig. 26. Push retaining spring into groove all the way around connecting rod.

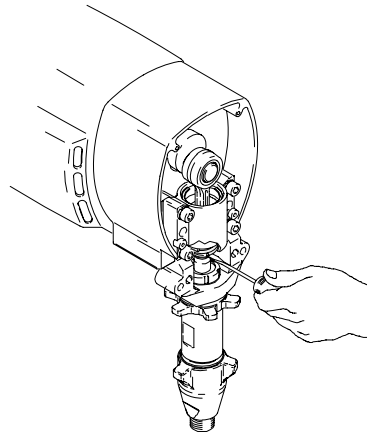

Fig. 26

Fig. 27. Screw jam nut down onto pump until stops. Screw pump up into bearing housing until it is stopped by jam nut. Back off pump and jam nut to align pump outlet to back. Tighten jam nut by hand, then tap 1/8 to 1/4 turn with a 20 oz (maximum) hammer to approximately 75 ± 5 ft-lb (102 N·m).

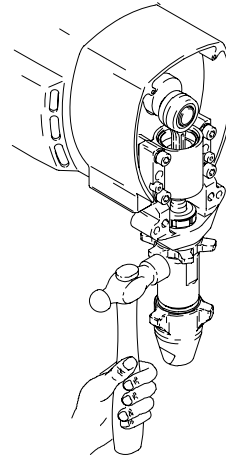

Fig. 27

Fig. 28. Fill packing nut with Graco TSL, through one of the slits, until fluid flows onto the top of seal.

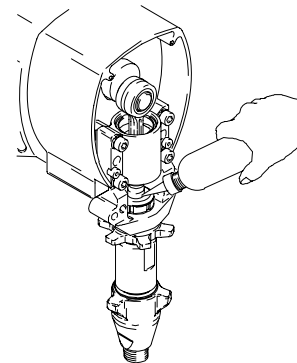

Fig. 28

Accessories

DANGER LABELS

The English language DANGER label shown on page 4 is also on your sprayer. If you have painters who do not read English, order one of the following labels to apply to your sprayer. The drawing shows the best placement of these labels for good visibility.

Order the labels directly from Graco, free of charge. Toll Free: 1-800-328-0211

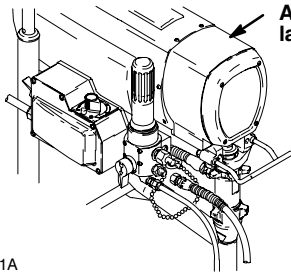

Apply other language here

French	185955
Spanish	185962
German	186042
Greek	186046
Korean	186050

7691A

Technical Data

Power Requirements	120 VAC, 60 Hz, 1 phase, 15A minimum or 4000W generator
Motor	1.0 HP (with latex at 2000 psi (138 bar, 13.8 MPa))
Working Pressure Range	0-3000 psi (0-210 bar, 0-21 MPa)
Cycles/Gallon (liter)	244 (64.6)
Maximum Delivery Rating	0.8 gpm (3 lpm)
Tip Size	one gun - 0.028; two guns - 0.019 (with latex at 2000 psi (138 bar, 13.8 MPa))
Power Cord	14 AWG, 3 wire, 15 ft (4.5 m)
Inlet Paint Strainer	16 mesh (975 micron) stainless steel screen, reusable
Outlet Paint Filter	60 mesh (238 micron) stainless steel screen, reusable
Pump Inlet Size	3/4 npt(m)
Fluid Outlet Size	3/8 npt(f)
Filter	Filter with standard 3/8 npt(f) to 1/4 npsm adapter 1/4 npsm
Basic Sprayer Wetted Parts:	zinc-plated carbon steel, polyurethane, polyethylene, stainless steel, PTFE, Delrin®, chrome plating, leather, V-Max™ UHMWPE, aluminum, stainless steel, tungsten carbide

NOTE: Delrin® is a registered trademark of the DuPont Co.

Dimensions

Weight (dry w/o packaging)	101 lb (46 kg)
Height	28.5 in. (724 mm)
Length	25.5 in. (648 mm)
Width	20.5 in. (521 mm)

Parts Drawing – Sprayer

Ultra MAX 795 Sprayers

Model 232-140, Series A
Includes items 1 – 112, 123, 126
Basic Sprayer

Model 232-141, Series A
Includes items 1 – 126
Complete Sprayer

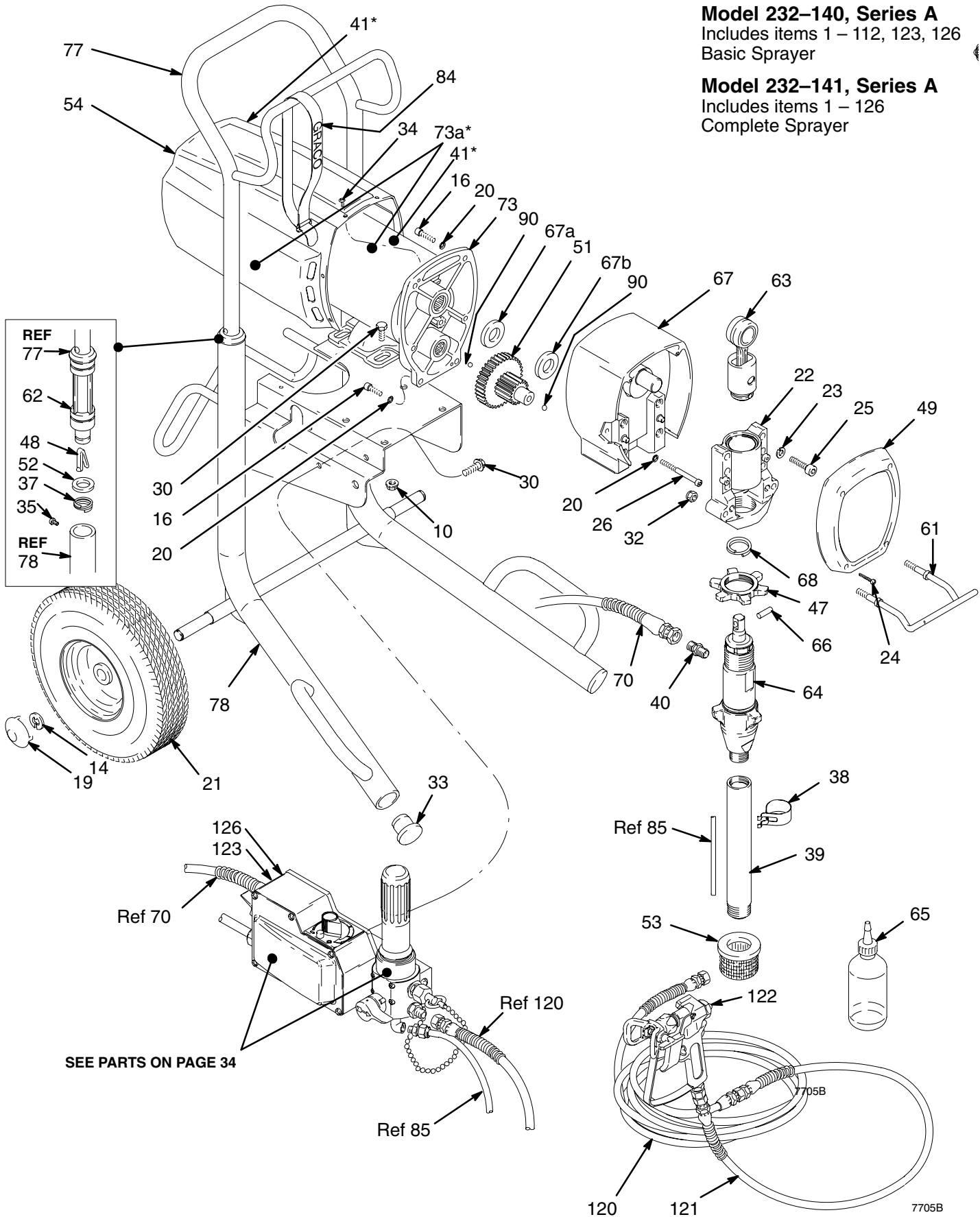

Parts List – Sprayer

Ultra MAX 795 Sprayers

Model 232–140 Series A

Includes items 1 – 112, 123, 126
Basic Sprayer

REF NO.	PART NO.	DESCRIPTION	QTY
10	110996	NUT, 5/16–18 unc–2a	4
14	101242	RING, retaining	2
16	100644	SCREW, socket head, 1/4–20 x 0.75 in.	4
19	104811	HUBCAP	2
20	105510	LOCKWASHER, spring, 1/4 in.	6
21	106062	WHEEL, semi–pneumatic	2
22	240523	BEARING HOUSING <i>includes 32 and 61</i>	1
23	106115	LOCKWASHER, spring, 3/8 in.	4
24	114406	SCREW, filh, no. 8–32 x1 in.	4
25	107210	CAPSCREW, sch, 3/8–16 x 1–1/2 in.	4
26	107218	CAPSCREW, sch, 1/4–20 x 2.75 in.	2
30	111801	SCREW, serrated flange, hex hd, 5/16–18 x 1/2 in.	7
32	112746	NUT, hex	2
33	108691	PLUG, tubing	2
34	108865	SCREW, pan head, no. 8 x 3/8 in.	6
35	109032	SCREW, pnhd, 10–32 x 1/4 in.	4
37	110243	RING, retaining	2
38	192691	CLIP, spring	1
39	192641	TUBE, intake	1
40	162453	NIPPLE, 1/4 npt(m) x 1/4 npsm	2
41	187791▲	LABEL, DANGER, English	2
47	192723	NUT, hex	1
48	112827	BUTTON, snap	2
49	179899	COVER, housing	1
51	179961	GEAR REDUCER	1
52	183350	WASHER	2
53	181072	STRAINER	1
54	240317	SHIELD, motor <i>includes labels 41 and 73a</i>	1
61	192719	HANGER, pail	1
62	192027	SLEEVE	2
63	218034	CONNECTING ROD	1

Model 232–141, Series A

Includes items 1 – 126
Complete Sprayer

REF NO.	PART NO.	DESCRIPTION	QTY
64	239923	DISPLACEMENT PUMP <i>see manual 308–798 for parts</i>	1
65	206994	THROAT SEAL LIQUID, 8 OZ	1
66	176818	PIN, straight, hdls, 0.3125 in. dia x 1.023 in.	1
67	239931	DRIVE HOUSING <i>includes 67a and 67b</i>	1
67a	178967	.WASHER, silver–colored	1
67b	107089	.WASHER, bronze–colored	1
68	176817	SPRING, retaining	1
70	239984	HOSE, grounded, nylon, 1/4 in. ID cpld 1/4 npsm (f), 25 in. (635 mm), spring guards both ends	1
73	240015*	MOTOR, ELECTRIC <i>includes 41 and 73a</i>	1
73a	187784▲	.LABEL, DANGER, French	2
77	239998	HANDLE, cart	1
78	239980	FRAME, sprayer	1
84	114271	STRAP, retaining	1
90	100069	BALL, steel, 1/4 in. dia.	2
97	192694	HOUSING, control, box	1
120	238361	HOSE, grounded, nylon, 1/4 in. ID, cpld 1/4 npsm(f), 50 ft (15 m) spring guards both ends	1
121	238358	HOSE, grounded, nylon, 3/16 in. ID, cpld 1/4 npsm(f), 3 ft (.9 m), spring guards both ends	1
122	220955	SPRAY GUN <i>see manual 307–614 for parts</i>	1
123	192838▲	LABEL, WARNING, French	1
126	187975▲	LABEL, WARNING, English	1

▲Extra Danger and Warning tags and labels available free.

*Motor Brush Repair Kit 220–853 is available.

Order separately.

Parts Drawing – Sprayer

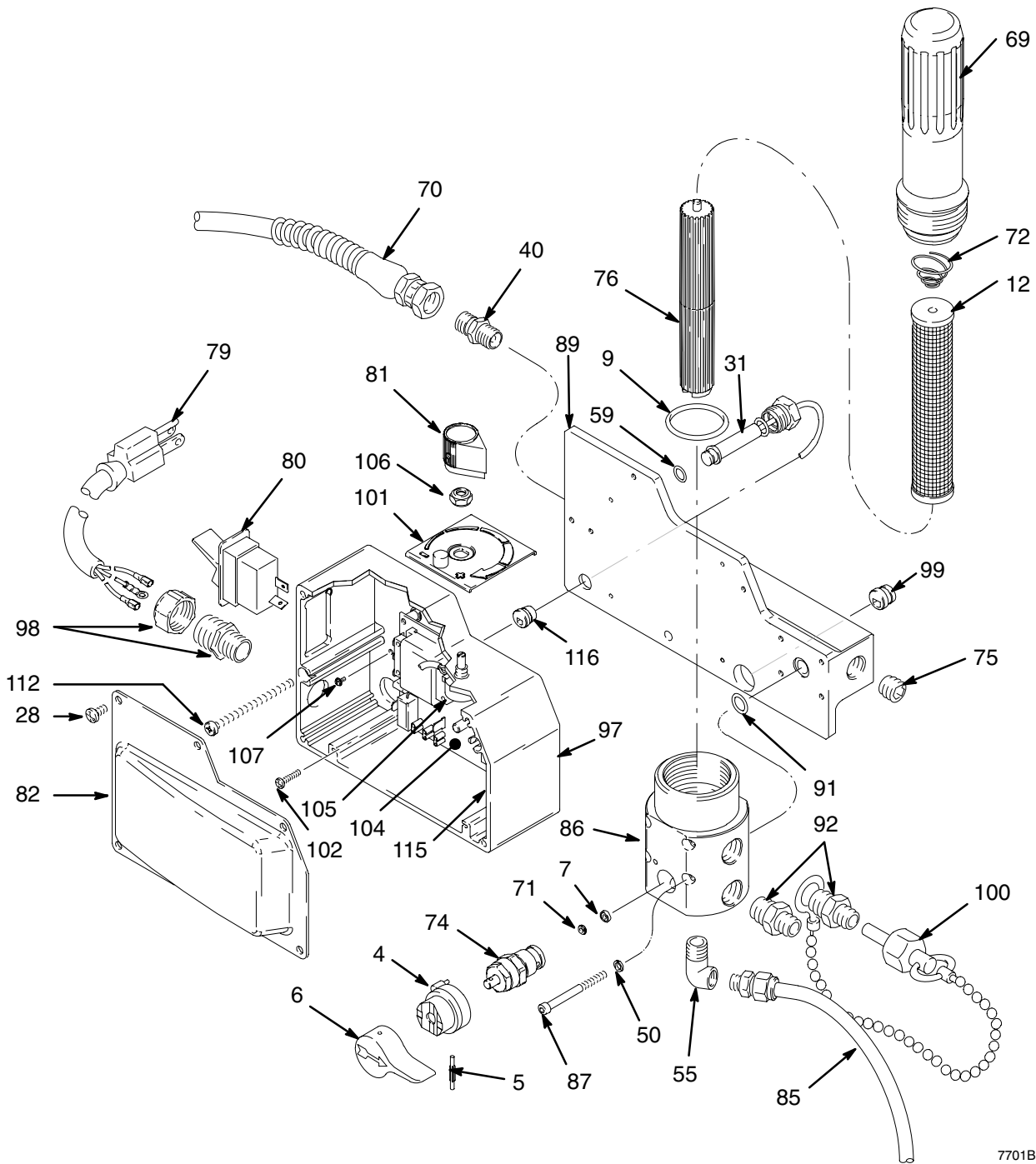

7701B

Parts List – Sprayer

Ultra MAX 795 Sprayers

Model 232–140, Series A

Includes items 1 – 112, 123, 126
Basic Sprayer

Model 232–141, Series A

Includes items 1 – 126
Complete Sprayer

REF NO.	PART NO.	DESCRIPTION	QTY	REF NO.	PART NO.	DESCRIPTION	QTY
4	224807	ASSEMBLY, cam, drain valve	1	86	240316	HOUSING, filter <i>includes item 9</i>	1
5	111600	PIN, grooved	1	87	107183	CAPSCREW	4
6	187625	HANDLE, valve, drain	1	89	192726	PLATE, housing, control	1
7	111699	GASKET, seat, valve	1	91	107505	PACKING, o-ring	1
9	104361	O-RING, packing	1	92	164672	ADAPTER	2
12	167025	STRAINER, mesh, 60	1	98	114284	BUSHING, strain relief	1
28	114392	SCREW, mach, panhd	5	99	114285	BUSHING, strain relief	1
31	240314	TRANSDUCER, pressure control <i>includes item 59</i>	1	100	240131	CAP, for secondary outlet	1
50	100020	WASHER, lock spring	4	101	192831	PLATE, instruction	1
55	112538	ELBOW, 90°, street, reducing	1	102	114420	SCREW, mach, panhd	4
59	111457	O-RING, packing	1	104	240168	BOARD, PC	1
69	240315	BOWL, filter <i>includes item 72</i>	1	105	236352	POTENTIOMETER, pressure adjust	1
71	187615	VALVE, seat	1	106	112382	NUT, shaft, sealing	1
72	171941	SPRING, compression	1	107	114391	SCREW, ground	1
74	235014	ASSEMBLY, drain valve includes items 7 and 71	1	111	240495	WIRE, jumper	1
75	100721	PLUG, pipe	1	112	114393	SCREW	3
76	186075	SUPPORT, filter	1	115▲	193051	LABEL, warning	1
79	239995	CORD SET, power	1	116	114409	BUSHING, strain relief	1
80	114277	SWITCH, rocker, (spst)	1				
81	114273	KNOB, potentiometer	1				
82	193012	COVER, painted	1				
85	240144	HOSE, drain	1				

▲Extra Danger and Warning tags and labels available free.

*Motor Brush Repair Kit 220–853 is available.
Order separately.

Wiring Diagram

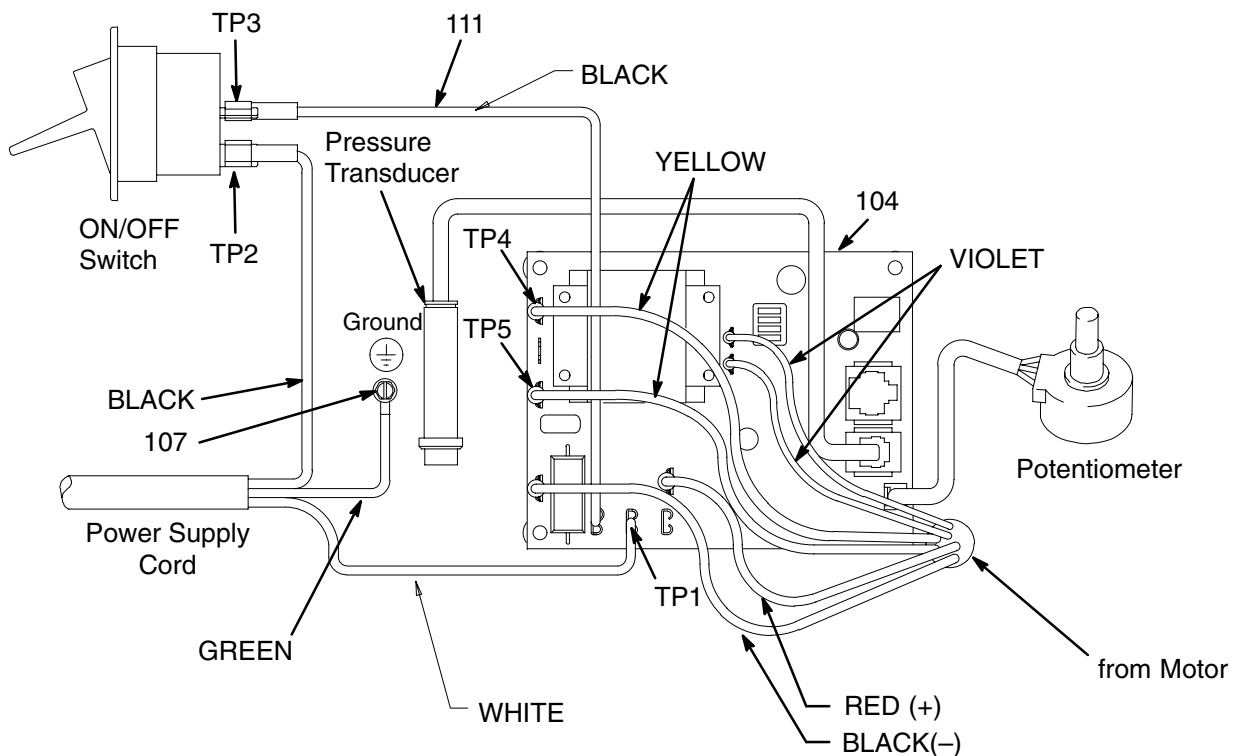

Fig. 29

7702A

Graco Standard Warranty

Graco warrants all equipment referenced in this document which is manufactured by Graco and bearing its name to be free from defects in material and workmanship on the date of sale by an authorized Graco distributor to the original purchaser for use. With the exception of any special, extended, or limited warranty published by Graco, Graco will, for a period of twelve months from the date of sale, repair or replace any part of the equipment determined by Graco to be defective. This warranty applies only when the equipment is installed, operated and maintained in accordance with Graco's written recommendations.

This warranty does not cover, and Graco shall not be liable for general wear and tear, or any malfunction, damage or wear caused by faulty installation, misapplication, abrasion, corrosion, inadequate or improper maintenance, negligence, accident, tampering, or substitution of non-Graco component parts. Nor shall Graco be liable for malfunction, damage or wear caused by the incompatibility of Graco equipment with structures, accessories, equipment or materials not supplied by Graco, or the improper design, manufacture, installation, operation or maintenance of structures, accessories, equipment or materials not supplied by Graco.

This warranty is conditioned upon the prepaid return of the equipment claimed to be defective to an authorized Graco distributor for verification of the claimed defect. If the claimed defect is verified, Graco will repair or replace free of charge any defective parts. The equipment will be returned to the original purchaser transportation prepaid. If inspection of the equipment does not disclose any defect in material or workmanship, repairs will be made at a reasonable charge, which charges may include the costs of parts, labor, and transportation.

THIS WARRANTY IS EXCLUSIVE, AND IS IN LIEU OF ANY OTHER WARRANTIES, EXPRESS OR IMPLIED, INCLUDING BUT NOT LIMITED TO WARRANTY OF MERCHANTABILITY OR WARRANTY OF FITNESS FOR A PARTICULAR PURPOSE.

Graco's sole obligation and buyer's sole remedy for any breach of warranty shall be as set forth above. The buyer agrees that no other remedy (including, but not limited to, incidental or consequential damages for lost profits, lost sales, injury to person or property, or any other incidental or consequential loss) shall be available. Any action for breach of warranty must be brought within two (2) years of the date of sale.

GRACO MAKES NO WARRANTY, AND DISCLAIMS ALL IMPLIED WARRANTIES OF MERCHANTABILITY AND FITNESS FOR A PARTICULAR PURPOSE, IN CONNECTION WITH ACCESSORIES, EQUIPMENT, MATERIALS OR COMPONENTS SOLD BUT NOT MANUFACTURED BY GRACO. These items sold, but not manufactured by Graco (such as electric motors, switches, hose, etc.), are subject to the warranty, if any, of their manufacturer. Graco will provide purchaser with reasonable assistance in making any claim for breach of these warranties.

In no event will Graco be liable for indirect, incidental, special or consequential damages resulting from Graco supplying equipment hereunder, or the furnishing, performance, or use of any products or other goods sold hereto, whether due to a breach of contract, breach of warranty, the negligence of Graco, or otherwise.

FOR GRACO CANADA CUSTOMERS

The parties acknowledge that they have required that the present document, as well as all documents, notices and legal proceedings entered into, given or instituted pursuant hereto or relating directly or indirectly hereto, be drawn up in English. Les parties reconnaissent avoir convenu que la rédaction du présente document sera en Anglais, ainsi que tous documents, avis et procédures judiciaires exécutés, donnés ou intentés à la suite de ou en rapport, directement ou indirectement, avec les procédures concernées.

ADDITIONAL WARRANTY COVERAGE

Graco does provide extended warranty and wear warranty for products described in the "Graco Contractor Equipment Warranty Program".

Graco Information

TO PLACE AN ORDER, contact your Graco distributor, or call **1-800-690-2894** to identify the nearest distributor.

*All written and visual data contained in this document reflects the latest product information available at the time of publication.
Graco reserves the right to make changes at any time without notice.*

MM 308800

Graco Headquarters: Minneapolis

International Offices: Belgium, China, Japan, Korea

GRACO INC. P.O. BOX 1441 MINNEAPOLIS, MN 55440-1441

<http://www.graco.com>

PRINTED IN USA 308800F

01/1997 Rev. 06/2005