

**TITAN**®  
TOOL INC.



OWNER'S MANUAL  
FOR PROFESSIONAL  
USE ONLY

313 - 1229

REV 0498

**TITAN** *Speeflo*



**DO NOT USE EQUIPMENT BEFORE READING THIS MANUAL**

# Epic™ 660HPX

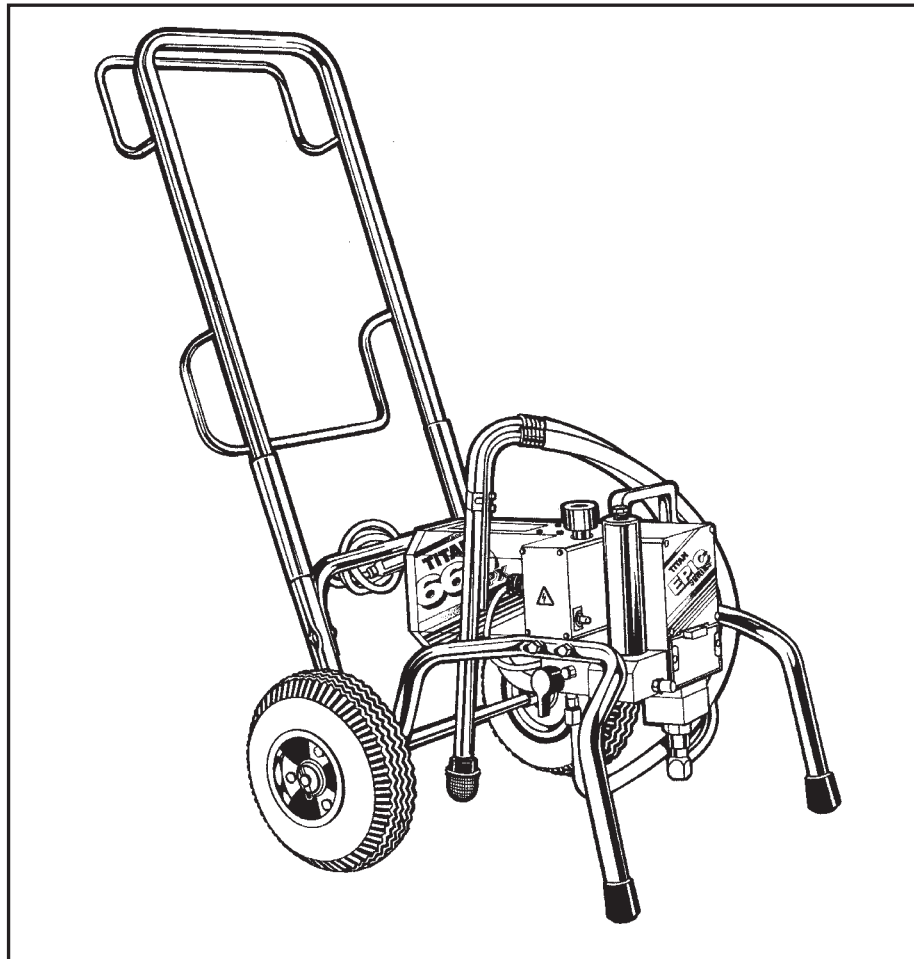

**Epic 660HPX**

120V Pump Only - 702-405

120V Complete - 702-410

230V Pump Only - 702-102-CE

230V Complete - 702-104-CE

This manual contains important warnings and instructions.  
Please read and retain for reference. Never operate this unit unless it is properly grounded.

# Epic 660HPX

## Table of Contents

Accessories	2
General Repairs/Service	3
Maintenance/Service Record	4
Warnings	5
Aviso (En Español)	6
Attention (En Français)	7
Notice: Fire or Explosion Hazards	8,9,10
Start-up Procedure	10, 11
Application Techniques	12
Cleaning Procedure	13
Airless Tip Selection	13
Troubleshooting	
Spray Pattern	13
Airless Gun	13
Airless Pump	14
Flushing Specifications	14

## Parts Drawings & Repair Information 15-25

Low Rider Frame.....	16
Replacement Labels.....	17
Armature Replacement.....	18
Electrical Schematics.....	20
Motor Housing.....	19
Gear Box.....	20
Gear Repair.....	21
On/Off Switch .....	21
Motor Starter, Brush Replacement.....	21
Filter Block.....	22
Pressure Switch.....	23
Prime Relief Valve.....	23
Filter Replacement.....	23
Fluid Section.....	24
Syphon Assembly & Down Tube.....	24
Pump Repair.....	25

Equipment Job History.....	26
High Rider Frame.....	27
Skid Frame.....	27
Specifications.....	28
Warranty.....	28

U.S. Patents: 3,936,002; 4,220,286; 4,457,472; 4,508,268; 4,494,697; 4,500,119; 4,626,004; 4,611,758; 4,744,571; 4,728,213; 4,768,932; 4,755,638; 4,768,929; 4,840,543; 4,908,538; 5,074,467; 5,425,506

## Accessories

### LIQUID SHIELD

Cleans and protects spray systems against rust, corrosion and premature wear.

Case of 12 (1 quart bottles) 700-888  
1 quart 700-889



### AIRLESS HOSE

I.D. x Length	Product No.
1/4" x 25'	316-513
1/4" x 50'	316-505
3/8" x 50'	690-375-50
3/16" x 9'	550-222
3/16" x 15'	550-221

### HIGH PRESSURE SWIVELS

Pressure Rated at 5000 psi

Gun-to-Hose  
1/4" NPS (F) x 1/4" NPS (M) 500-428

Hose-to-Hose  
1/4" NPS (M) x 1/4" NPS(M) 500-424

### PISTON SEAL LUBRICANT

Specially formulated to prevent materials from adhering to the piston rod, which becomes abrasive to the upper seals. Piston Lube will break down any material that may accumulate in the wet cup and keep it from drying.

8 oz individual 700-925  
1 qt individual 700-926  
8 oz, case of 12 700-911  
1 qt, case of 12 700-912



### FITTINGS

1/4" x 1/4" Hose Coupling	490-012
1/4" x 3/8" Hose Coupling	490-016
3/8" x 3/8" Hose Coupling	490-014
T-Fittings, 1/4" x 1/4"	490-036
Tip Filter Retainer	520-046
1/4" Mx1/4"F Swivel Union	490-005
1/4" Mx3/8"F Swivel Union	490-032
Retaining Nut Adapter	490-007
High Pressure Fl. Gauge	730-394

# Epic 660HPX

120V Pump Only - 702-405  
230V Pump Only - 702-102-CE

120V Complete - 702-410  
230V Complete - 702-104-CE

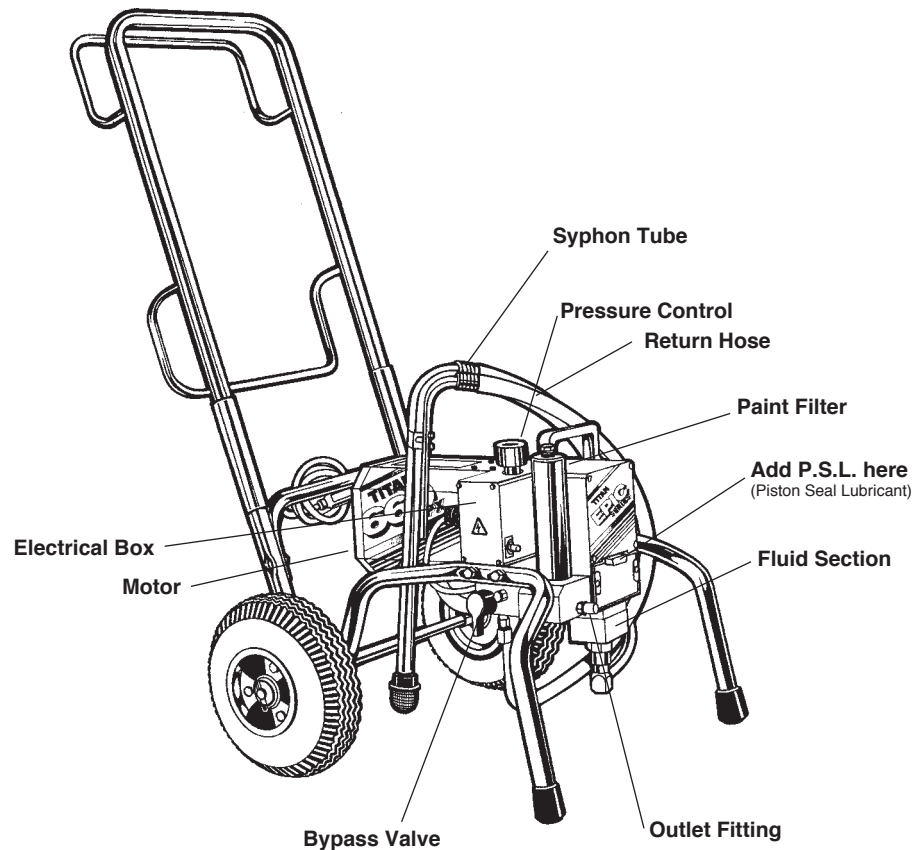

Figure 1

**NOTE:** A Repacking Kit (730-401) is available. All parts included in the kits are listed in the parts list chart on page 24. For best results use all parts supplied in the Repacking Kit.

## General Repair & Service Notes:

**WARNING:** Before proceeding, follow the Pressure Relief Procedure outlined on Page 5. Additionally, follow all other warnings to reduce the risk of an injection injury, injury from moving parts or electric shock. Always unplug the sprayer before servicing!

The following tools are needed when repairing this sprayer:

Phillips Screwdriver	3/8" Allen Wrench
Needle Nose Pliers	5/16" Allen Wrench
Adjustable Wrench	1/4" Allen Wrench
Rubber Mallet	3/16" Allen Wrench
Flat-blade Screwdriver	1/8" Allen Wrench
1/2" Open End Wrench	

1. Before repairing any part of the sprayer, read the instructions carefully, including all warnings.
2. When disconnecting wires, use needle nose pliers to separate mating connectors.

**CAUTION:** Never pull on a wire to disconnect it. Pulling on a wire could loosen the connector from the wire.

3. Test your repair before regular operation of the sprayer to be sure that the problem is corrected. If the sprayer does not operate properly, review the repair procedure to determine if everything was done correctly. Refer to the Troubleshooting Charts to help identify other possible problems.
4. Make certain that the service area is well ventilated in case solvents are used during cleaning. Always wear protective eyewear while servicing. Additional protective equipment may be required depending on the type of cleaning solvent. Always contact the supplier of solvents for recommendations.
5. If you have any further questions concerning your **TITAN** Airless Sprayer, call **TITAN**:

Customer Service Department Tel. **1-800-526-5362**

Fax **1-800-528-4826**

Outside the U.S. Call **1-201-405-7520**

Fax **1-201-405-7449**

Canada Tel **1-800-565-8665**

Fax **1-905-856-8496**

MODEL #	SERIAL #	DATE PURCHASED	COMPANY NAME
---------	----------	----------------	--------------

Titan Tool is in the business of designing and manufacturing spray systems and accessories that make today's Painting Professional become more efficient and profitable. We feel that if you accurately track the maintenance of your equipment on this chart it will improve the performance of this valuable tool to help you get the most out of your investment.

The chart is easy to follow and to use. The Maintenance Schedule allows for the recording of all your service work and will help you make sure your unit is always running at peak performance.

Make sure to fill in the boxes at the top of this record with the model number, serial number, date purchased and your company name. This information will be needed to validate your warranty.

## Electric Pump Maintenance Schedule

**Check Piston Seal Lubricant Level WEEKLY.**

**EPIC 660HPX**

**Electric Motor Models**

<b>Check Motor Brushes Every 200 Hours</b>	Date	Date	Date	Date	Date	Date	Date	Date	Date	Date
--	------	------	------	------	------	------	------	------	------	------

## Service Record

Date	Service Center	Service Performed	Warranty Repair
Months in Service	Cost of Repair		<input type="checkbox"/> Yes <input type="checkbox"/> No
Date	Service Center	Service Performed	Warranty Repair
Months in Service	Cost of Repair		<input type="checkbox"/> Yes <input type="checkbox"/> No
Date	Service Center	Service Performed	Warranty Repair
Months in Service	Cost of Repair		<input type="checkbox"/> Yes <input type="checkbox"/> No
Date	Service Center	Service Performed	Warranty Repair
Months in Service	Cost of Repair		<input type="checkbox"/> Yes <input type="checkbox"/> No
Date	Service Center	Service Performed	Warranty Repair
Months in Service	Cost of Repair		<input type="checkbox"/> Yes <input type="checkbox"/> No
Date	Service Center	Service Performed	Warranty Repair
Months in Service	Cost of Repair		<input type="checkbox"/> Yes <input type="checkbox"/> No
Date	Service Center	Service Performed	Warranty Repair
Months in Service	Cost of Repair		<input type="checkbox"/> Yes <input type="checkbox"/> No

May Be Copied For Field Use

**DO NOT USE EQUIPMENT BEFORE READING THIS SECTION**

**WARNING**  
**HIGH PRESSURE SPRAY**  
**CAN CAUSE SERIOUS INJURY**  
**Maximum Working Pressure 3200 psi, 221 bar**

An airless spray gun requires that fluid be introduced to it at very high pressure. Fluids under high pressure, from spray or leaks, can penetrate the skin and inject substantial quantities of toxic fluid into the body. If not promptly and properly treated, the injury can cause tissue death or gangrene and may result in serious, permanent disability or amputation of the wounded part. Therefore, extreme caution must be exercised when using any airless spray equipment. **IF YOU ARE INJECTED, SEE A PHYSICIAN IMMEDIATELY. DO NOT TREAT AS A SIMPLE CUT!**

**NOTE TO PHYSICIAN:** Injection into the skin is a serious, traumatic injury. It is important to treat the injury surgically as soon as possible. Do not delay treatment to research toxicity. Toxicity is a concern with some exotic coatings injected directly into the bloodstream. Consultation with a plastic surgeon or a reconstructive hand surgeon may be advised.

1) Handle the spray gun carefully. Keep clear of the nozzle. **NEVER** point the gun at yourself or anyone else. **NEVER** permit any part of your body to come in contact with the fluid stream of either the gun or any hose leak. **ALWAYS** keep the gun trigger safety lever in a locked position when not spraying. **ALWAYS** use a tip safety guard.

2) **NEVER** attempt to force the flow of fluid backward through the gun with your finger, hand or hand-held object against the gun nozzle. **THIS IS NOT AN AIR SPRAY GUN.**

3) **NEVER** attempt to remove tip, disassemble or repair equipment without first doing the following:

4) Before flushing system, always

**PRESSURE RELEASE PROCEDURE**

**A. Set trigger safety in a locked position**

**B. Shut off pump and unplug electrical cord**

**C. Release fluid pressure from entire system and trigger gun**

**D. Reset trigger safety in a locked position**

remove spray tip and adjust fluid pressure to lowest possible setting.

5) Tighten all fluid connections before each use. **NEVER** exceed 3200 psi with this unit. Make sure that all accessory hoses, connections, swivels and so forth can withstand the high pressures which

develop. **NEVER** exceed the pressure rating of any component in the system.

6) **WARNING:** The paint hose can develop leaks from wear, kinking, abuse, etc. A leak is capable of injecting fluid into the skin, therefore the paint hose should be inspected before each use. **NEVER** attempt to plug a hose with any part of your body, adhesive tape or any other makeshift device. Do not attempt to repair a spray hose. Instead, replace it with a new grounded hose. Use only with hoses that have spring guards. **NEVER** use less than 50' of hose with this unit.

7) Be sure that the airless equipment being used and the object being sprayed are properly grounded to prevent static discharge or sparks which could cause fire or explosion. **WARNING: ALWAYS** hold the gun against metal container when flushing system with tip removed, to prevent static discharge. **CAUTION:** To reduce the risk of electrical shock, do not expose to rain. Store indoors.

**GROUNDING INSTRUCTIONS:** This product should be grounded. In the event of an electrical short circuit, grounding reduces the risk of electric shock by providing an escape wire for the electric current. This product is equipped with a cord having a grounding wire with an appropriate grounding plug. The plug must be plugged into an outlet that is properly installed and grounded in accordance with all local codes and ordinances.

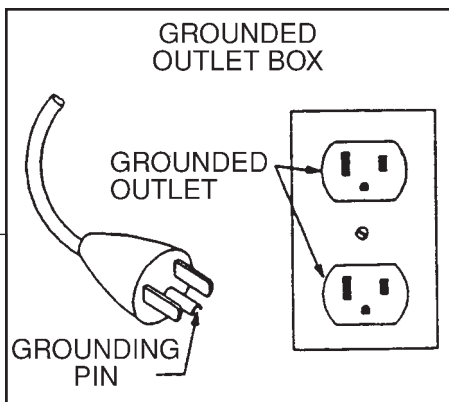

**DANGER** - Improper installation of the grounding plug can result in a risk of electric shock. If repair or replacement of the cord or plug is necessary, do not connect the grounding wire to either flat blade terminal. The wire with insulation having an outer surface that is green (with or without yellow stripes) is the grounding wire. Check with a qualified electrician or serviceman if the grounding

instructions are not completely understood, or if in doubt as to whether the product is properly grounded. Do not modify the plug provided; if it will not fit the outlet, have the proper outlet installed by a qualified electrician.

- This product is for use on a nominal 120-volt circuit and has a grounding plug that looks like the plug illustrated below.
- Make sure that the product is connected to an outlet having the same configuration as the plug. No adapter should be used with this product.

**EXTENSION CORDS:** Use only a 3-wire extension cord that has a 3-slot receptacle that will accept the plug on the pump. Make sure your extension cord is in good condition. When using an extension cord, be sure to use one heavy enough to carry the current this pump will draw.

For lengths less than	Use extension gauge
50 ft. (15 meters)	14 AWG
100 ft. (30 meters)	12 AWG
150 ft. (45 meters)	10 AWG

An undersized cord will cause a drop in line voltage resulting in loss of power and overheating. If in doubt, use the next heavier gauge. The smaller the gauge number, the heavier the cord.

8) **ALWAYS** keep the working area around the pump well ventilated. Additionally, the pump itself should be a minimum of 25' (7.5m) from the spray area. If these instructions are not followed, there is the possibility of fire or explosion with certain materials.

**ALWAYS** follow the coating or solvent manufacturer's safety precautions and warnings. Never spray flammable material near open flames, pilot lights or any source of ignition.

9) **ALWAYS** wear spray masks and protective eyewear while spraying. Additional personal protective equipment may be required depending on the type of material being sprayed and conditions of ventilation. Always contact supplier of material being sprayed for recommendation.

10) Keep all extension poles clear of electrical wires.

11) **NEVER** alter or modify any part of this equipment; doing so could cause it to malfunction.

12) **NEVER** leave equipment unattended. Keep away from children or anyone not familiar with the operation of airless equipment.

NO USE EL EQUIPO ANTES DE LEER ESTA SECCION

# ADVERTENCIA

## LA ROCIADURA A PRESION ALTA PUEDE CAUSAR LESION GRAVE.

**Presión de Trabajo Máxima 3200 libras por pulgada cuadrada (psi), 221 bar**

Una pistola rociadora sin aire requiere que se le introduzca líquido a presión muy alta. Los líquidos bajo presión alta, de la rociadura o de las fugas, pueden penetrar en la piel e inyectar en el cuerpo cantidades considerables de líquido tóxico. Si no se atiende rápida y apropiadamente, la lesión puede causar muerte del tejido o gangrena, y puede resultar en incapacidad seria y permanente o en la amputación de la parte lesionada. Por lo tanto, hay que emplear precauciones estrictas al usar cualquier equipo de rociadura sin aire. **SI USTED HA ESTADO EXPUESTO A LA PENETRACION DE TOXICOS POR INYECCION, CONSULTE INMEDIATAMENTE AL MEDICO. ¡NO TRATE LA HERIDA COMO SI FUERA UNA MERA CORTADURA!**

**NOTA PARA EL MEDICO:** La penetración de tóxicos en la piel es una herida seria y traumática. Es importante tratar la herida quirúrgicamente lo más pronto posible. No demore el tratamiento para investigar la toxicidad. La toxicidad es asunto serio cuando se trata de la penetración de ciertos revestimientos tóxicos en la corriente sanguínea. Puede que sea necesaria la consulta con un cirujano plástico o un cirujano especialista en la reconstrucción de la mano.

1) Maneje la pistola de rociadura con cuidado. Manténgase alejado de la boquilla. **JAMAS** apunte la pistola hacia usted u otra persona. **NUNCA** permita que parte alguna de su cuerpo se ponga en contacto con el chorro de líquido de la pistola o de alguna fuga de la manguera. **SIEMPRE** mantenga trabado el seguro de la pistola mientras no esté rociando. **SIEMPRE** utilice el protector de seguridad de la boquilla.

2) **JAMAS** intente forzar el flujo del líquido por la pistola hacia atrás con el dedo, la mano o un objeto sostenido con la mano contra la boquilla de la pistola, ya que **NO SE TRATA DE UNA PISTOLA DE ROCIADURA DE AIRE.**

3) **JAMAS** intente quitar la boquilla ni desarmar o reparar el equipo sin haber cumplido antes con los pasos siguientes:

### PROCEDIMIENTO DE DESCOMPRESION

- Coloque el seguro de la pistola en posición trabada.
- Apague la bomba y desconecte también el cable de electricidad.
- Descargue la presión del líquido de todo el sistema y de la pistola.
- Vuelva a trabar el seguro.

4) Antes de lavar el sistema, siempre quite la boquilla de rociadura y ajuste la presión del líquido al valor más bajo posible.

5) Ajuste todas las conexiones antes de cada uso. **JAMAS** supere 3200 libras por pulgada cuadrada con esta unidad. Asegúrese de que todas las mangueras, conexiones, articulaciones

giratorias y demás elementos accesorios estén en condiciones de tolerar las altas presiones que se presentan. **JAMAS** exceda la clasificación de presión de cualquier componente del sistema.

6) **ADVERTENCIA:** La manguera de pintura puede presentar fugas como resultado del desgaste, retorcimiento, abuso, etc. Las fugas pueden inyectar líquido a través de la piel, por lo que la manguera de pintura debe ser inspeccionada antes de cada uso. **JAMAS** intente obtener la manguera con una parte de su cuerpo o con tela adhesiva o cualquier otro elemento improvisado. No intente reparar una manguera de rociadura; en cambio reemplácela con una manguera nueva conectada a tierra. Utilice solamente mangueras con protector de resorte. **JAMAS** use una manguera de menos de 15,2 m con esta unidad. Almacenar bajo techo.

### INSTRUCCIONES PARA LA PUESTA A

**TIERRA:** Este producto debe conectarse a tierra. En caso de corto circuito, la conexión a tierra proporciona una vía de escape para la corriente eléctrica y reduce el riesgo de choques eléctricos. El producto está dotado de un cable provisto de un alambre y de un enchufe de puesta a tierra. El enchufe debe enchufarse en un tomacorriente debidamente instalado y dotado de conexión a tierra, de acuerdo con las estipulaciones de los códigos y ordenanzas locales.

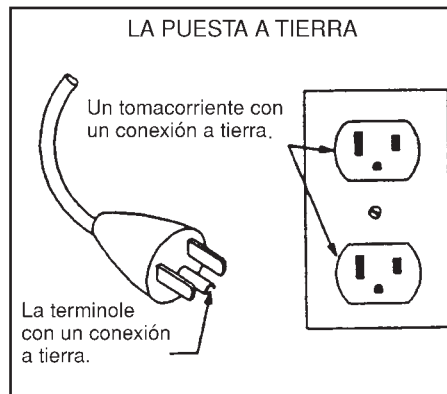

**PELIGRO** — La instalación incorrecta del enchufe de puesta a tierra podría crear el riesgo de choque eléctrico. Si es necesario reparar o reemplazar el cordón o el enchufe, no conecte el alambre de puesta a tierra a ninguna de las dos terminales de cuchilla plana. El alambre con aislamiento exterior verde, con o sin rayas amarillas, es el alambre de puesta a tierra. Consulte a un electricista o técnico competente si no comprende bien las instrucciones para la conexión a tierra o si tiene dudas de que el producto está conectado a tierra correctamente. No modifique el enchufe que viene con el producto; si no encaja en el tomacorriente, pida a un electricista competente que instale el tomacorriente apropiado.

• Este producto ha sido diseñado para usarse en un circuito de tensión nominal de 120 voltios y

está dotado de un enchufe de puesta a tierra semejante a la ilustrada más adelante.

• Asegúrese de que el producto esté enchufado en un tomacorriente que tenga la misma configuración del enchufe. No debe usarse ningún adaptador.

**CORDON DE EXTENSION** — Use sólo un cordón de extensión trifilar que tenga un enchufe de puesta a tierra con tres cuchillas, y un receptáculo con tres ranuras que acepte el enchufe que viene con el producto. Cerciórese de que el cordón de extensión esté en buen estado. Al usar un cordón de extensión, cerciórese de que sea suficientemente grueso para transportar la corriente que su producto usará.

Para tramos de menos de:	Use cordones de calibre:
15,2 m	14 AWG
30,4 m	12 AWG
45,7 m	10 AWG

Un cordón demasiado corto provocará una caída de la tensión, ocasionando una pérdida de potencia y recalentamiento. Si tiene dudas, use un calibre más grueso. Cuanto más pequeño sea el número de calibre, más grueso será el cable.

7) Asegúrese de que el equipo sin aire que esté empleando y el objeto que se intenta rociar estén correctamente conectados a tierra para evitar descargas estáticas o chispas que podrían ocasionar incendio o explosión. **ADVERTENCIA:** Sostenga **SIEMPRE** la pistola contra el receptáculo de metal al limpiar el sistema con la boquilla desprendida, para evitar la descarga estática. **ADVERTENCIA:** Para reducir riesgo de descarga eléctrica, no exponer a la lluvia.

8) **SIEMPRE** mantenga el lugar de trabajo alrededor de la bomba bien ventilado. Además, la bomba en sí debe estar ubicada a no menos de 7,6 m de la operación de rociadura. Si no se observan estas instrucciones, existe el riesgo de incendio o explosión con ciertos materiales.

**SIEMPRE** observe las precauciones y advertencias de los fabricantes sobre revestimientos y solventes. Nunca rocíe material inflamable cerca de llamas expuestas, llamas piloto o cualquier fuente de ignición.

9) **SIEMPRE** use máscaras apropiadas y anteojos de protección durante la operación de rociadura. Según el tipo de material que se está rociando y las condiciones de ventilación puede ser necesario usar equipo personal protector adicional. Siempre comuníquese con el proveedor del material para conseguir recomendaciones.

10) Mantenga todas las varas de extensión fuera del alcance de cables eléctricos.

11) **JAMAS** altere o modifique parte alguna de este equipo, ya que ello puede causar deficiencias de funcionamiento.

12) **JAMAS** deje al equipo solo. Manténgalo fuera del alcance de los niños o de cualquier persona no familiarizada con la operación de equipo sin aire.

NE PAS UTILISER LE MATERIEL AVANT D'AVOIR LU CETTE SECTION

# ATTENTION!

## LES PULVERISATEURS A HAUTE PRESSION PEUVENT PROVOQUER DE SERIEUSES LESIONS

Pression de travail maximale: 3200 psi — 221 bar

Le liquide introduit dans un pistolet pulvérisateur sans air doit l'être à pression extrêmement élevée. Les liquides à haute pression, en provenance du pulvérisateur ou d'une fuite quelconque, sont capables de pénétrer la peau et d'injecter d'importantes quantités de liquide toxique dans l'organisme. Si elle n'est pas traitée promptement et avec toute l'attention voulue, la lésion causée de la sorte peut provoquer la nécrose des tissus ou la gangrène et donner lieu à de sérieux handicaps permanents, voire à l'amputation du membre atteint. Une prudence extrême s'impose donc lors de l'utilisation de matériel de pulvérisation sans air.

**EN CAS D'INJECTION, CONSULTEZ UN MEDECIN IMMEDIATEMENT. NE TRAITER PAS LA BLESSURE COMME S'IL S'AGISSAIT D'UNE SIMPLE COUPURE!**

**REMARQUE A L'INTENTION DU MEDECIN :**

Une injection pénétrant la peau constitue une lésion traumatique grave qu'il est important de traiter chirurgicalement aussitôt que possible. Ne perdez pas de temps à rechercher la toxicité de l'injection. Il s'agit là d'un risque à envisager en cas d'injection directe dans le circuit sanguin de certains revêtements exotiques. La consultation d'un chirurgien plasticien ou d'un spécialiste de la chirurgie reconstructive de la main peut être conseillée.

1) Maniez le pistolet avec soin. Maintenez-vous à l'écart de la buse. N'en dirigez **JAMAIS** la buse vers aucune partie de votre corps ou vers aucune autre personne. Ne laissez **JAMAIS** aucune partie de votre corps entrer en contact avec le flux de liquide s'échappant du pistolet ou d'une fuite quelconque au niveau du flexible. Verrouillez **TOUJOURS** le levier de sûreté de la détente lorsque vous n'êtes pas occupé à pulvériser. **Veillez à TOUJOURS utiliser un dispositif de sûreté à la buse du pistolet.**

2) N'essayez **JAMAIS** de refouler le flux de liquide dans le pistolet au moyen de votre doigt, de votre main ou d'un objet maintenu contre la buse du pistolet. **CET APPAREIL N'EST PAS UN PISTOLET PULVERISATEUR A AIR.** N'utilisez aucune pièce de matériel sans air avec une pompe non équipée d'une soupape de surpression.

3) N'essayez **JAMAIS** d'enlever la buse, de démonter ou de réparer l'appareil avant d'avoir accompli la procédure suivante :

### PROCEDURE DE DELESTAGE DE PRESSION

- A. Verrouillez la sûreté de la détente.
- B. Arrêtez la pompe et débranchez le cordon électrique.
- C. Délestez la pression dans tout le système et appuyez sur la détente du pistolet.
- D. Reverrouillez la sûreté de la détente.

4) Avant de procéder au rinçage du système,

enlevez toujours la buse de pulvérisation et réglez la pression au niveau le plus faible possible.

5) Serrez bien tous les raccords du système hydrodynamique avant chaque emploi. Ne dépassez **JAMAIS**, avec cet appareil, une pression de 3200 psi. Assurez-vous que tous les flexibles accessoires, raccords, articulations, etc. sont bien capables de résister aux hautes pressions prévues. Ne dépassez **JAMAIS** la capacité de pression nominale d'aucun composant du système. **DANGER :** Afin de réduire tout risque d'électrocution, n'exposez pas à la pluie.

6) **ATTENTION :** Des fuites risquent de se produire le long du flexible de peinture sous l'effet de l'usure, des torsions, des rudes traitements, etc. auxquels il est éventuellement soumis. Les injections de liquide dans la peau sont possibles par la voie de telles fuites. Il est donc important d'inspecter le flexible avant chaque usage. N'essayez **JAMAIS** d'obtenir une fuite à l'aide de votre doigt ou de tout autre membre de votre corps, de ruban adhésif ou de tout autre moyen de fortune. N'essayez pas non plus de réparer un flexible de pulvérisation ; remplacez-le plutôt par un nouveau flexible mis à la terre. Veillez à n'utiliser que les flexibles munis de dispositifs de sécurité à ressort. N'utilisez **JAMAIS** moins de 15,2 m de flexible avec cet appareil.

7) Assurez-vous que le matériel sans air utilisé et que l'objet à peindre sont adéquatement mis à la terre, de façon à éviter toute décharge d'électricité statique ou toute étincelle susceptible de provoquer un incendie ou une explosion.

**ATTENTION :** Tenez **TOUJOURS** le pistolet contre un récipient en métal lors du rinçage du système, après en avoir ôté la buse. Ne vaporisez **JAMAIS** de substances inflammables à proximité de flammes nues, lampes témoin ni d'aucune source d'allumage. Rangez à l'intérieur.

**INSTRUCTIONS DE MISE A LA TERRE :** Ce produit doit être mis à la terre. Dans l'hypothèse d'un court-circuit électrique, la mise à la terre réduit le risque de chocs électriques en assurant un fil de fuite pour le courant électrique. Ce produit est pourvu d'un cordon possédant un fil de terre avec fiche appropriée de mise à la terre. La fiche doit être branchée sur une prise qui est posée et mise à la terre adéquatement conformément à tous les

électriques. Si le cordon ou la fiche doit être réparé ou remplacé, ne raccordez pas le fil de terre à l'une ou l'autre borne à lame plate. Le fil possédant une isolation dont la surface extérieure est verte (avec ou sans rayures jaunes) est le fil de terre. Consultez un électricien ou un technicien de service compétent si vous ne comprenez pas parfaitement les instructions de mise à la terre ou si vous ne pouvez affirmer avec certitude que le produit est dûment mis à la terre. Ne modifiez pas la fiche fournie ; si elle ne rentre pas dans la prise, faites poser la prise appropriée par un électricien compétent.

- Ce produit est destiné à être utilisé sur un circuit à tension nominale de 120 volts et a une fiche de terre qui ressemble à la fiche illustrée ci-après.
- S'assurer que le produit est branché sur une prise ayant la même configuration que la fiche. Aucun adaptateur ne doit être utilisé avec ce produit.

**CORDONS DE RALLONGE** - Utilisez uniquement un cordon de rallonge à trois fils pourvu d'une fiche de mise à la terre à trois lames, et une prise à trois fentes qui acceptera la fiche de la pompe. Assurez-vous que votre cordon de rallonge est en bon état. Lorsque vous utilisez un cordon de rallonge, veillez à en utiliser un suffisamment puissant pour transporter le courant que consommera cette pompe.

Pour les longueurs de moins de:	Utilisez une rallonge de calibre:
15,2 m	14 AWG
30,4 m	12 AWG
45,7 m	10 AWG

Un cordon sous-calibré provoquera une chute de tension secteur ayant pour conséquences une perte de puissance et une surchauffe. En cas de doute, utilisez le calibre immédiatement plus puissant. Plus le numéro de calibre est bas, plus le cordon est puissant.

8) Le moteur électrique de cet appareil n'est pas protégé contre les explosions. Il est donc essentiel d'assurer une bonne ventilation de la zone de travail et des alentours de la pompe. Il est également important de maintenir la pompe à une distance minimale de 7,6 m de la zone de pulvérisation. Certains matériaux présentent, à défaut de suivre ces consignes, un risque d'incendie ou d'explosion. Suivez **TOUJOURS** les précautions et avertissements du fabricant de chaque solvant ou revêtement utilisé.

9) Portez **TOUJOURS** un masque et des lunettes de protection lors de vos travaux de pulvérisation. D'autres articles de protection personnelle peuvent être nécessaires suivant le type de produit pulvérisé et les conditions d'aération. Demandez toujours ses recommandations à votre fournisseur.

10) Maintenez toutes les tiges de rallonge à distance des fils électriques.

11) N'altérez ou ne modifiez **JAMAIS** une partie quelconque de cet appareil, ce qui pourrait causer des défaillances.

12) Ne laissez **JAMAIS** le matériel sans surveillance. Gardez-le hors de portée des enfants et de toute personne inexpérimentée quant à l'usage de matériel sans air.

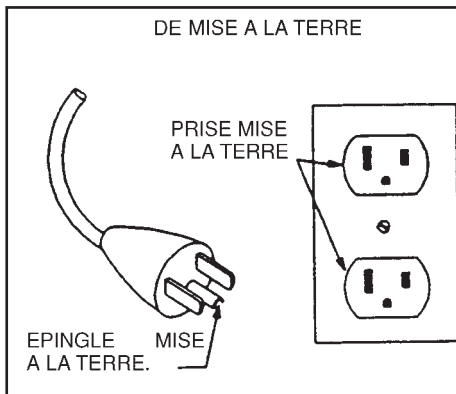

codes et règlements locaux.

**DANGER** - La pose inappropriée de la fiche de terre peut provoquer un risque de chocs

## FIRE OR EXPLOSION HAZARD

Static electricity is created by the high velocity of fluid through the pump, hose and tip. If every part of the spray element is not properly grounded, sparking may occur and the system may become hazardous. Sparking may also occur when plugging in or unplugging a power supply cord, or starting a gas engine. Sparks can ignite fumes from solvents or the fluids being sprayed. Always plug the sprayer into an outlet at least 25' (7.5m) away from the spray area. **WARNING: Always flush the unit into a separate metal container with the spray tip removed and the gun held firmly against the side of the container to assure proper grounding and prevent static discharge which could cause serious bodily injury.**

If you experience any static sparking or slight shock while using this equipment, stop spraying immediately. Check the entire system for proper grounding. Do not use the system again until the problem has been corrected.

### ELECTRIC MOTOR

The electric motors used by TITAN are not explosion proof. Therefore, it is essential to keep the working area around the pump well ventilated. Additionally, the pump itself should be a minimum of 25' (7.5m) from the spray area. **WARNING: Always keep pump outside of any enclosed spray area. Never clean the exterior of the pump with any flammable solvents.**

### GAS ENGINE (Where Applicable)

Always keep pump outside of any enclosed spray area. Keep area around pump well ventilated. Keep all solvents away from engine exhaust. (Never fill the fuel tank while the engine is running or hot. Fuel spilled on a hot surface can ignite and cause a fire.) Always attach ground wire located on rear of engine to a grounded object, i.e. water pipe. **NOTE: Refer to engine owner's manual for additional safety and service information.**

### FLUID SECTION—SOLVENTS

Halogenated Hydrocarbon solvents can cause an explosion when used with aluminum or galvanized components in a closed (pressurized) fluid system (pumps, heaters, filters, valves, spray guns, tanks, etc.). The explosion could cause serious injury, death and/or substantial property damage. Cleaning agents, coatings, paints, etc. may contain Halogenated Hydrocarbon solvents. Titan Tool Inc. spray equipment includes aluminum or galvanized components and will be affected by Halogenated Hydrocarbon solvents. **DO NOT USE HALOGENATED HYDROCARBONS IN TITAN EQUIPMENT.**

### EXPLANATION OF THE HAZARD

There are three key elements to the Halogenated Hydrocarbon (HHC) solvent hazard. These elements are:

1. The presence of HHC solvents.
2. Aluminum or galvanized parts.
3. Equipment capable of withstanding pressure.

When all three elements are present, the result can be an extremely violent explosion. The reaction can be sustained with very little aluminum or galvanized metal: any amount of aluminum is too much. The reaction is unpredictable. Prior use of an HHC solvent without incident (corrosion or explosion) does NOT mean that such use is safe.

## PELIGRO DE INCENDIO O EXPLOSIÓN

La alta velocidad del líquido a través de la bomba, manguera y la boquilla produce electricidad estática. Si algún componente del equipo de rociadura no está conectado a tierra correctamente pueden producirse chispas y el sistema se vuelve peligroso. También pueden producirse chispas al enchufar o desenchufar cables eléctricos o al poner en funcionamiento un motor a gasolina. Las chispas pueden encender los vapores provenientes de los solventes o de los líquidos rociados. Siempre conecte el rociador a un enchufe ubicado a no menos de 7,5m de distancia de la zona de rociadura. **ADVERTENCIA: Lavar siempre la unidad en un recipiente metálico separado, habiendo quitado la boca del rociador y teniendo la pistola firmemente contra el lado del recipiente para asegurar una puesta a tierra correcta y evitar la descarga estática que podría causar lesión corporal grave.**

Si ocurren chispas de electricidad estática o si sufre un shock eléctrico ligero mientras usa el equipo, deje de rociar de inmediato. Verifique que el sistema en su totalidad esté conectado a tierra correctamente. No vuelva a usar el sistema hasta que el problema haya sido resuelto.

### MOTOR ELÉCTRICO:

Los motores eléctricos utilizados por TITAN no son a prueba de explosión. Por lo tanto, es esencial mantener el área de trabajo alrededor de la bomba bien ventilada. Además, la bomba misma debe estar a una distancia mínima de 7,5m del área de rociadura. **ADVERTENCIA: Mantener siempre la bomba afuera de cualquier área de rociadura cerrada. Nunca limpie el exterior de la bomba con solventes inflamables.**



## **MOTOR A GASOLINA: (Si fuera aplicable)**

Siempre mantenga la bomba afuera de cualquier zona de rociadura cerrada. Mantenga el área alrededor de la bomba bien ventilada. Mantenga todos los solventes lejos del escape del motor. (Nunca liene el tanque de combustible cuando el motor esté funcionando o caliente. El combustible derramado sobre una superficie caliente puede encenderse y producir un incendio). El cable a tierra que está ubicado en la parte de atrás del motor debe estar siempre adherido a un objeto conectado a tierra, por ejemplo, una cañería de agua. **NOTA:** Vea el manual de uso del motor para información adicional sobre seguridad y mantenimiento.

## **SECCION FLUIDO—SOLVENTES**

Los solventes a base de hidrocarburos halogenados pueden provocar explosión cuando se usan con componentes galvanizados o de aluminio en un sistema líquido cerrado (sujeto a presión) (bombas, calefactores, filtros, válvulas, pistolas de rociadura, tanques, etc.) La explosión podría causar lesiones serias e inclusive la muerte, así como daños materiales de consideración. Los líquidos de limpieza, revestimientos, pinturas, etc. pueden contener solventes a base de hidrocarburos halogenados. El equipo de rociadura ofrecido por Titan Tool Inc. tiene componentes galvanizados o de aluminio y será afectado por solventes a base de hidrocarburos halogenados. **NO USE HIDROCARBUROS HALOGENADOS EN EL EQUIPO TITAN.**

## **EXPLICACION DEL RIESGO**

Hay tres elementos fundamentales que condicionan el riesgo de los hidrocarburos halogenados, a saber:

- 1. Presencia de solventes de hidrocarburos halogenados.**
- 2. Componentes galvanizados o de aluminio.**
- 3. Equipo capaz de tolerar presión.**

Cuando todos estos elementos están presentes, el resultado puede ser una explosión sumamente violenta. La reacción puede tener lugar aun cuando la cantidad de aluminio o metal galvanizado sea muy pequeña: cualquier cantidad de aluminio es excesiva. La reacción no puede predecirse. El hecho de que un solvente a base de hidrocarburos halogenados haya sido usado anteriormente sin accidentes (corrosión o explosión) NO significa que dicho uso no es peligroso.

## **DANGER!**

## **RISQUE D'INCENDIE OU D'EXPLOSION**

La vitesse du liquide à travers la pompe le flexible et la buse produit de l'électricité statique. Si tous les éléments du matériel de pulvérisation ne sont pas mis à la terre de manière adéquate, ils risquent de favoriser la production d'étincelles et de rendre le système dangereux. Des étincelles peuvent également se produire lors de branchement ou débranchement d'un cordon d'alimentation électrique ou lors de la mise en marche d'un moteur au gaz. De telles étincelles sont susceptibles d'enflammer les vapeurs des solvants ou les liquides pulvérisés. Veillez donc toujours à brancher le pulvérisateur dans une prise située à au moins 7,5m du pulvérisateur et de la zone de travail. **MISE EN GARDE: Toujours rincer l'appareil dans un récipient métallique distinct après avoir enlevé le bec de pulvérisation et en tenant fermement le pistolet contre le côté du récipient afin d'assurer une mise à la terre appropriée et de prévenir une décharge statique susceptible de causer des blessures graves.**

Si vous remarquez la formation d'étincelles sous l'effet de la présence d'électricité statique ou que vous ressentez une légère décharge électrique en cours d'utilisation du matériel, arrêtez immédiatement la pulvérisation. Assurez-vous que tous les éléments du système sont bien mis à la terre. Ne remettez pas le système en marche avant d'avoir résolu le problème.

## **MOTEUR ÉLECTRIQUE**

Les moteurs électriques utilisés par TITAN ne sont pas protégés contre les explosions. Il est donc essentiel d'assurer une bonne ventilation de la zone de travail et des environs de la pompe. Il est également important de maintenir la pompe à une distance minimale de 7,5m de la zone de pulvérisation. **ATTENTION:** N'introduisez jamais la pompe dans une zone de pulvérisation fermée. Ne nettoyez jamais nettoyer l'extérieur de la pompe à l'aide de solvants inflammables.

## **MOTEUR AU GAZ (le cas échéant)**

N'introduisez jamais la pompe dans une zone de pulvérisation fermée. Veillez à ce que les environs de la pompe soient toujours bien aérés. Ne placez aucun solvant à proximité du système d'échappement du moteur. (Ne remplissez jamais le réservoir à carburant lorsque le moteur tourne ou s'il est chaud. Renversé sur une surface chaude, le gaz pourrait s'enflammer et provoquer un incendie.) Veillez à toujours bien raccorder le fil de terre situé à l'arrière du moteur à un objet mis à la terre (par exemple, une conduite d'eau). **REMARQUE:** Pour plus de détails sur les mesures de sécurité et d'entretien pertinentes, consultez le manuel fourni avec le moteur.

## **SECTION HYDRODYNAMIQUE—SOLVANTS**

Les solvants à hydrocarbure halogéné sont explosifs en présence de pièces galvanisées ou en aluminium dans un système hydrodynamique fermé (pressurisable) (pompes, radiateurs, filtres, soupapes, pistolets pulvérisateurs, réservoirs, etc.) L'explosion provoquée pourrait donner lieu à des lésions corporelles graves ou même mortelles et/ou à de sérieux

dégâts matériels. Certains produits d'entretien, revêtements, peintures et autres liquides contiennent des solvants à hydrocarbure halogéné. Les appareils pulvérisateurs de la Titan Tool Inc. comportent des pièces en aluminium et des composants galvanisés sensibles aux solvants à hydrocarbure halogéné. **N'EMPLOYER PAS D'HYDROCARBURES HALOGÉNÉS DANS LE MATÉRIEL TITAN.**

## EXPLICATION DU RISQUE

Le danger que présentent les solvants à hydrocarbure halogéné se caractérise par trois éléments clés:

1. **La présence de solvants à hydrocarbure halogéné**
2. **La présence de pièces en aluminium ou galvanisées**
3. **Un matériel capable de supporter des pressions élevées**

La combinaison de ces trois éléments peut donner lieu à une explosion extrêmement violente. La réaction peut se produire en présence d'une quantité minimale d'aluminium ou de métal galvanisé. En fait, la moindre trace d'aluminium en constitue déjà trop.

La réaction est imprévisible. Toute utilisation antérieure de solvant à hydrocarbure halogéné n'ayant donné lieu à aucun incident (corrosion ou explosion) NE CONSTITUE NULLEMENT un signe de sécurité.

## HALOGENATED SOLVENTS

**DEFINITION -- Any hydrocarbon solvent containing any of the elements as listed below:**

Consult your material supplier to determine whether your solvent or coating contains Halogenated Hydrocarbon Solvents.

## SOLVENTES HALOGENADOS

**DEFINICION -- Cualquier solvente a base de hidrocarburos que contenga cualquiera de estos elementos:**

EJEMPLOS (lista parcial):

Consulte la información suministrada por su proveedor de materiales para determinar si un solvente o revestimiento contiene solventes de Hidrocarburos Halogenados.

## SOLVANTS HALOGÉNÉS

**DÉFINITION -- Tout solvant à hydrocarbure contenant l'un des éléments suivants:**

EXEMPLES (liste incomplète):

Pour déterminer si vos solvants ou revêtements contiennent des solvants à hydrocarbure halogéné, consultez votre fournisseur.

**Fluorine (F) "-fluor-"**      **Chlorine (Cl) "-chloro-"**  
**Bromine (Br) "-bromo-"**      **Iodine (I) "-lodo-"**

### EXAMPLES

(not all-inclusive):

FLUOROCARBON SOLVENTS:

Dichlorofluoromethane

Trichlorofluoromethane

BROMINATED SOLVENTS:

Ethylene dibromide

Methylene chlorobromide

Methyl bromine

IODINATED SOLVENTS:

N-butyl iodide

Methyl iodide

Ethyl iodide

Propyl iodide

CHLORINATED SOLVENTS:

Carbon tetrachloride

Chloroform

Ethylene dichloride

METHYLENE CHLORIDE or

DICHLOROMETHANE

Monochlorobenzene

Orthodichlorobenzene

Perchloroethylene

TRICHLOROETHANE

Trichloroethylene

Monochlorotoluene

## START-UP PROCEDURE

**WARNING:** High pressure device, thoroughly read and understand the warning section located in the owner's manual and the label on the sprayer.

**IMPORTANT:** Whenever starting or cleaning this sprayer, always reduce engine or motor speed. Additionally, never operate this sprayer for more than 10 seconds without fluid, this can cause unnecessary wear to the packings.

**Do not operate dry.**

**Step 1:** Before you plug in the power cord to the electrical outlet or start the gas engine, do the following:

A. Tighten suction and return hoses, then install a minimum of 50' (7.5m) of nylon airless spray hose and airless gun. Do not install tip yet, or remove if installed. **WARNING:** If you are supplying your own hoses and spray gun, be sure they are electrically grounded and rated for at least 3200 psi (221 bar) working pressure, and that the gun has a tip guard. This is to reduce the risk of serious bodily injury caused by static sparking and fluid injection or overpressurization, causing a component rupture.

- B. Preset pressure control by turning the pressure control knob counterclockwise to lowest setting.
- C. Place on-off switch in the off position.
- D. Be sure to fill the Wet Cup 1/3 full with Piston Seal Lubricant.

**Step 2E: ELECTRIC MOTOR**

- A. Check electrical service. Be sure it is 120V 15 amp minimum and that outlet is properly grounded.
- B. Plug electrical cord into a grounded outlet that is at least 25' (7.5m) from the spray area. **Make certain that all extension cords are a three wire, 12 gauge minimum cord with a grounded plug. Never remove third prong or use an adaptor. Never exceed 150' (45m) of extension cord.**
- C. If a secondary hose and gun is not installed be sure the plug is secure.
- D. Place the suction tube into container containing mineral spirits.

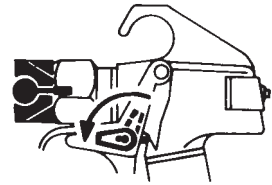

Lock position

**Step 2G: GAS ENGINE (Where Applicable)**

- A. **Check the engine oil level.** For instructions refer to the engine manual supplied.
- B. **Fill the gas tank.** Be sure the engine is cool. Refueling a hot engine could cause a fire. Close the black fuel shut off lever located under the air cleaner. **Use unleaded high quality gasoline.**
- C. If a secondary hose and gun is not installed, be sure the plug is secure.
- D. Place the suction tube into container containing mineral spirits.
- E. Open the fuel shut off lever by pushing it in the direction of the arrow.
- F. Move the throttle lever away from fuel tank.
- G. Close the engine choke lever, located beneath the air cleaner.
- H. Turn the engine switch on. Turn pressure relief prime valve down to prime position.
- I. Pull the starter rope. Holding the frame with one hand, pull the rope rapidly and firmly. Continue to hold the rope as you let it return. Pull and return rope until engine starts.

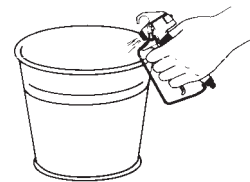

Remove Tip and Safety Guard when flushing

**Step 3:** Flush oil out of new paint pump: Oil is used by the factory for testing and protection. It is necessary to flush out with mineral spirits before you begin to spray.

- A. Pour 1/2 gallon mineral spirits into a metal container and insert syphon and return tube.
- B. Turn pressure relief prime valve down to prime position and turn unit on. Increase pressure slightly. Let solvent cycle for approximately 30 seconds. Then tilt syphon tube above container and let the sprayer pump itself dry. Then turn unit off. If you are going to use water based paints, repeat procedure using water.

**Step 4:** Prepare the paint according to manufacturer's recommendations. Remove any skin that may have formed and stir. Strain the paint through a fine nylon mesh bag to remove particles that could clog spray tip.

**Step 5:** Place syphon and return tubes into paint container. Turn pressure relief priming knob, located on side of pump, down for priming.

**Step 6:** Turn sprayer on and turn up pressure slightly. Let circulate on prime until no bubbles filter up through the paint.

**Step 7:** Hold gun firmly against a metal container, disengage trigger lock and trigger gun against side of container. Then, while gun is triggered, turn the pressure relief valve to the spray position. Keep the gun triggered until all the air is forced out of the system and the paint flows freely. Release the trigger and engage gun safety lock; set gun down while unit pressurizes.

**Step 8:** Check for leaks. If any leaks occur, follow the proper pressure relief procedure before tightening.

**Step 9:** Turn off sprayer and relieve pressure by turning pressure relief prime knob to prime.

**Step 10:** With gun trigger lock engaged, install tip and guard as instructed in separate tip or gun manual.

**Step 11:** Turn sprayer on and rotate the pressure relief prime valve to the spray position.

**Step 12:** Test on cardboard to check spray pattern. Adjust pressure just until the spray from gun is completely atomized.

# APPLICATION TECHNIQUES

The following techniques, if followed, will assure professional painting results.

Hold the gun perpendicular to the surface and always at equal distance from the surface. Depending on the type of material, surface or desired spray pattern, the gun should be held at a distance of 12 to 14 inches (30 to 35cm).

Move the gun either across or up and down the surface at a steady rate. Moving the gun at a consistent speed conserves material and provides even coverage. The correct spraying speed allows a full wet coat of paint to be applied without runs or sags.

Holding the gun closer to the surface deposits more paint on the surface and produces a narrower spray pattern. Holding the gun farther from the surface produces a thinner coat and wider spray pattern. If runs, sags or excessive paint occur, change to a spray tip with a smaller orifice. Conversely, if there is an insufficient amount of paint on the surface or you desire to spray faster, a larger orifice tip should be selected.

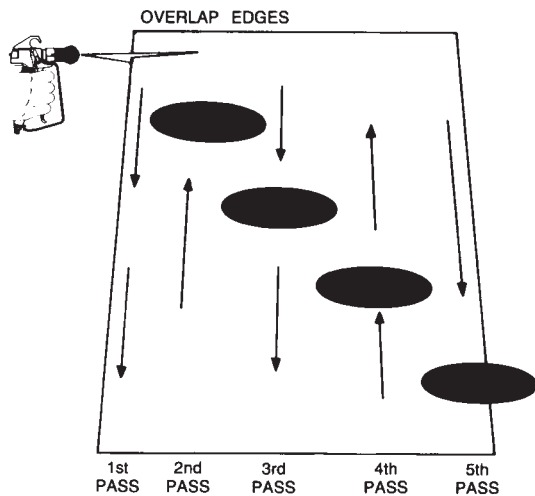

For corners and edges, split the center of the spray pattern on the corner or edge and spray vertically so that both adjoining sections receive approximate even amounts of paint.

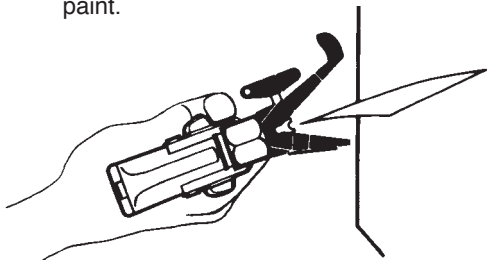

**When spraying with a shield**, hold it firmly against the surface. Angle the spray gun slightly away from the shield and toward the surface. This will prevent paint from being forced underneath.

**Shrubs next to houses should be tied back** and covered with a canvas cloth. The cloth should be removed as soon as possible. Titan Gun Extensions are extremely helpful in these situations.

**Nearby objects such as automobiles, outdoor furniture, etc., should be moved or covered** whenever in the vicinity of a spray job. Be careful of any other surrounding objects that could be damaged by overspray.

## Proper Technique

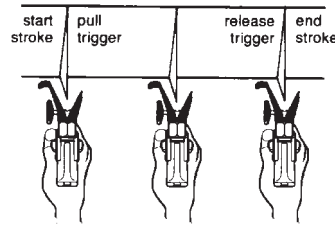

Maintain uniform spray stroke action. Spray alternately from left to right and right to left. Begin movement of the gun before the trigger is pulled.

## Wrong Technique

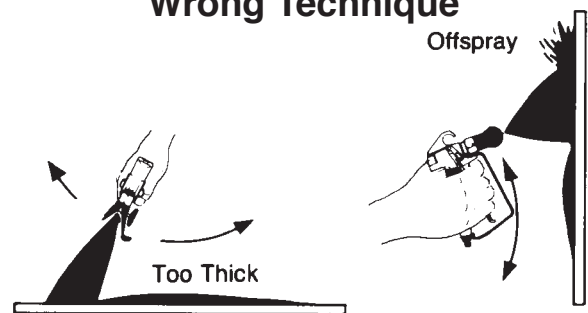

Avoid arcing or holding the gun at an angle. This will result in an uneven finish.

**PROPER LAPPING** (overlap of spray pattern) is essential to an even finish. Lap each stroke. If you are spraying horizontally, aim at the bottom edge of the preceding stroke, so as to lap the previous pattern by 50%.

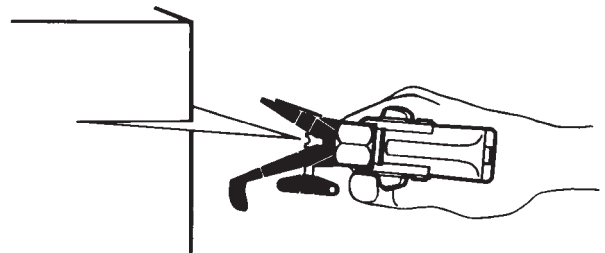

If conditions are windy, angle the spray pattern into the wind to minimize drifting. Work from ground to roof. Do not attempt to spray if wind is excessive.

# Cleaning Procedure

**WARNING:** High pressure device -- Follow all safety warnings located on sprayer and in the owner's manual. Always clean using low pressure, with the spray tip removed. Always flush into a separate metal container away from the sprayer. Never clean the exterior of the pump while the pump is plugged in or operating.

## PRESSURE RELEASE PROCEDURE:

**Step 1:** Engage trigger safety lock on gun.

**Step 2:** Turn off pump and release fluid pressure by turning the pressure relief prime valve located on the side of pump down.

## LOW PRESSURE CLEANING PROCEDURE:

**Step 3:** Remove tip and let soak clean, in a small container of solvents or water. Adjust fluid pressure to lowest possible setting.

**Step 4:** Turn the pump on. Tilt syphon tube above paint container, allowing the sprayer to pump itself dry through the return tube.

**Step 5:** Have available container of hot soapy water if spraying latex (or suitable solvent for oil base paints). Do not clean with mineral spirits if using latex paint as this will make jelly.

**Step 6:** Place syphon tube into container with hot soapy water or solvents. Let circulate for 2-3 minutes, then turn unit off.

**Step 7:** To save paint still in spray hose, turn prime valve up to spray position, then carefully trigger gun into and against side of metal paint container. Be careful of splashing. When cleaning solution appears, shut off gun and place gun in a separate metal container. Repeat process if spraying with two guns.

**Step 8:** Trigger gun and let cleaning solution circulate for approximately 2-3 minutes, then turn unit off.

**Step 9:** Turn prime valve down and remove suction tube from cleaning container. Turn unit on and allow sprayer to pump dry.

**Step 10:** Take a clean container of water or solvent and using low pressure pump through system until clear. If cleaning with water, pump a small amount of mineral spirits or TITAN LS-10 solution through pump. This will protect against corrosion.

**Step 11:** Take suction tube out of container and let sprayer run itself dry.

**Step 12:** Check filter on pump and gun. Clean or replace.

**Step 13:** Remove spray tip from solvent, clean with a soft bristle brush and store in a dry place.

# TROUBLESHOOTING AIRLESS GUN

PROBLEM	PROBABLE CAUSE	REMEDY
Spitting gun	1. Air in system 2. Dirty gun 3. Needle assembly out of adjustment 4. Broken or chipped seat	1. Inspect connections for air leaks 2. Disassemble and clean 3. Inspect and adjust 4. Inspect and replace
Gun will not shut off	1. Worn or broken needle & seat 2. Needle assembly out of adjustment 3. Dirty gun	1. Replace 2. Adjust 3. Clean
Gun does not spray	1. No paint 2. Plugged filter or tip 3. Broken needle in gun	1. Check fluid supply 2. Clean 3. Replace

# TROUBLESHOOTING SPRAY PATTERNS

PROBLEM	PROBABLE CAUSE	REMEDY
Tails	1. Inadequate fluid delivery 2. Fluid not atomizing 3. Insufficient velocity 4. Material too cohesive 5. Tip worn past pump capacity	1. Increase pressure 2. Change to smaller tip 3. Clean gun & pump filters 4. Reduce viscosity 5. Replace
Heavy centered pattern	1. Worn tip 2. Tip may be chipped	1. Replace 2. Replace
Distorted pattern	1. Plugged, worn or chipped tip	1. Clean or replace
Pattern expanding and contracting (Surge)	1. Leak in suction tube 2. Not enough hose  3. Tip too large or worn	1. Tighten 2. Use a minimum of 50' (15m) of 1/4" high pressure hose 3. Replace with a new or smaller tip

# Airless Tip Selection

Tips are selected by the orifice size and fan width. The proper selection is determined by the fan width required for a specific job and by the orifice size that will supply the desired amount of fluid and accomplish proper atomization.

For light viscosity fluids, smaller orifice tips generally are desired. For heavier viscosity materials, larger orifice tips are preferred. Please refer to the chart below.

**Note: Do not exceed the pump's recommended tip size.**

The following chart indicates the most common sizes and the appropriate materials to be sprayed.

.011 - .013	Lacquers & Stains	100 Mesh Filter
.015 - .019	Oil & Latex	50 Mesh Filter
.021 - .026	Heavy Bodied Latex & Blockfillers	5 Mesh Filter

Fan widths measuring 8" to 12" are most preferred because they offer more control while spraying and are less likely to plug.

## Flushing Specifications

**1. New Sprayer:** Oil is used by the factory for testing and protection. It is necessary to flush unit before spraying.

A. If spraying water-base paint, flush with mineral spirits followed by water.

B. If spraying oil-base paint, flush with mineral spirits only.

**2. Changing from water-base to oil base:** Flush with water, then mineral spirits.

**3. Changing from oil-base to water-base:** Flush with mineral spirits, then water.

**4. Changing colors:** Flush with a compatible solvent such as water or mineral spirits.

**5. Storage:** To assure proper performance and long life, always clean the sprayer thoroughly before storing.

**A. Water-Base Paint:** Flush with water, then mineral spirits and leave the pump, gun and hose filled with mineral spirits. Shut off and unplug the sprayer and turn pressure relief prime valve to prime to relieve pressure. Return prime valve to spray position.

**B. Oil-Base Paint:** Flush with mineral spirits. Shut off and unplug the sprayer, turn the pressure relief prime valve to prime to relieve pressure and leave open. Return prime valve to spray position.

• During storage the power cord must be coiled around cord holder to avoid damage.

### 6. Start-Up After Storage:

**A. Water-Base Paint:** Flush out mineral spirits with water.

**B. Oil-Base Paint:** Flush out the mineral spirits with the material to be sprayed.

Always dispose of mineral spirits in a proper way.

## TROUBLESHOOTING AIRLESS PUMP

PROBLEM	PROBABLE CAUSE	REMEDY
Electric motor won't run	<ol style="list-style-type: none"> <li>1. Unit unplugged or circuit fuse blown</li> <li>2. Pressure setting too low</li> <li>3. Brushes on motor are worn</li> <li>4. Electric motor burned out</li> <li>5. Switch defective</li> <li>6. Fuse in pump blown</li> </ol>	<ol style="list-style-type: none"> <li>1. Check</li> <li>2. Increase</li> <li>3. Replace</li> <li>4. Replace</li> <li>5. Replace</li> <li>6. Replace</li> </ol>
Gas engine won't start (where applicable)	<ol style="list-style-type: none"> <li>1. Engine switch not on</li> <li>2. Engine oil level low</li> <li>3. Out of gas</li> <li>4. Spark plug cable disconnected or bad plug</li> </ol>	<ol style="list-style-type: none"> <li>1. Turn on</li> <li>2. Try starting engine. If light on rear glows, add oil</li> <li>3. Fill</li> <li>4. Connect or replace</li> </ol>
Pump won't prime	<ol style="list-style-type: none"> <li>1. Air in line</li> <li>2. Insufficient pressure</li> <li>3. Clutch worn or damaged (Gas models)</li> </ol>	<ol style="list-style-type: none"> <li>1. Check syphon tube O-Ring and/or let paint circulate in prime position</li> <li>2. Increase pressure</li> <li>3. Replace</li> </ol>
Insufficient material flow	<ol style="list-style-type: none"> <li>1. No paint</li> <li>2. Syphon strainer clogged</li> <li>3. Pump/gun filter clogged</li> <li>4. Pump will not prime, material too heavy</li> <li>5. Engine not tuned properly (Gas)</li> <li>6. Worn clutch (Gas models)</li> </ol>	<ol style="list-style-type: none"> <li>1. Check supply</li> <li>2. Clean</li> <li>3. Clean &amp; replace</li> <li>4. Thin material</li> <li>5. Tune engine</li> <li>6. Service</li> </ol>
Pump will not maintain pressure	<ol style="list-style-type: none"> <li>1. Air leak in system</li> <li>2. Air leak in syphon tube</li> <li>3. Inlet valve not seating</li> <li>4. Worn packings</li> <li>5. Dirty or worn ball valves</li> <li>6. Worn valve seats</li> <li>7. Worn prime valve</li> </ol>	<ol style="list-style-type: none"> <li>1. Tighten connections</li> <li>2. Tighten, check for leaks</li> <li>3. Service or clean</li> <li>4. Replace</li> <li>5. Clean or replace</li> <li>6. Reverse valve seats</li> <li>7. Replace</li> </ol>
Not enough pressure	<ol style="list-style-type: none"> <li>1. Pressure setting too low</li> <li>2. Plugged filters</li> <li>3. Spray tip too big or worn</li> <li>4. Engine or motor rpm too low (Gas)</li> </ol>	<ol style="list-style-type: none"> <li>1. Increase</li> <li>2. Clean or replace</li> <li>3. Change or replace</li> <li>4. Increase throttle</li> </ol>
Excessive surge at spray gun	<ol style="list-style-type: none"> <li>1. Wrong type of hose</li> <li>2. Spray tip too big or worn</li> <li>3. Excessive pressure</li> </ol>	<ol style="list-style-type: none"> <li>1. Replace with a minimum 50' grounded nylon braid high pressure hose</li> <li>2. Change or replace</li> <li>3. Decrease pressure and engine speed</li> </ol>
Paint leaks into oil cup	<ol style="list-style-type: none"> <li>1. Worn out packings</li> </ol>	<ol style="list-style-type: none"> <li>1. Replace</li> </ol>

# 230V Service Instructions

## Electrical Schematic for 230 Volt Motors

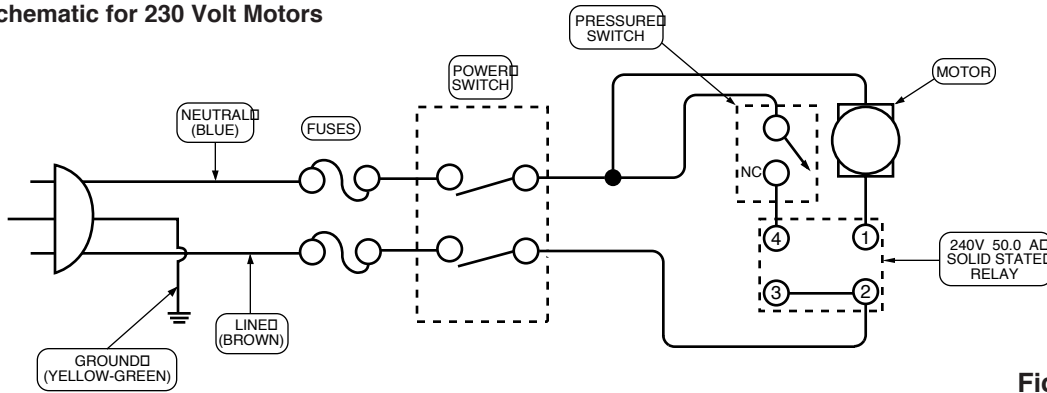

Figure 3A

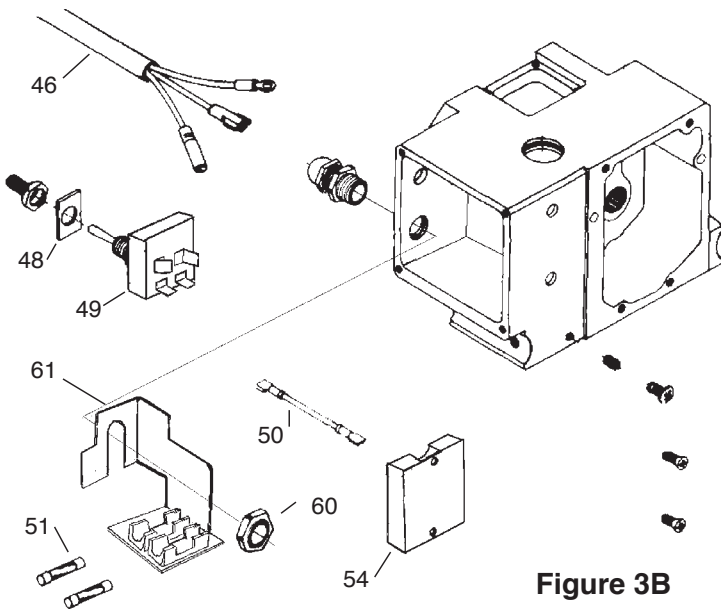

Figure 3B

### For 230 Volt Units:

ITEM NO	PART NO	DESCRIPTION	QTY
46	761-725	Power Cord	1
48	770-593	On/Off Plate	1
49	765-083	Toggle Switch	1
50	765-072	Wire	3
51	700-720	230V Fuse 10 Amp	2
54	765-050	Motor Starter	1
	313-098	Earth Symbol Label	1
60	765-087	Lock Nut	1
61	765-089	Fuse Block Assembly	1

(See pages 18, 19 & 20 for additional and related diagrams.)

**WARNING:** Before proceeding, follow the Pressure Relief Procedure outlined on Page 5. Additionally, follow all other warnings to reduce the risk of an injection injury, injury from moving parts or electric shock. Always unplug the sprayer before servicing!

## On/Off Switch Replacement

1. Remove Cover Plate and screws (#56 & #55). See pg. 20.
2. Disconnect the four wires from the On/Off Switch (#49).
3. Remove the rubber boot and plate (#47 & #48) with a wrench.
4. Remove the On/Off Switch (#49).
5. Install a new Switch and reattach plate and rubber boot. Tighten securely.
6. Reconnect the four wires to the new On/Off Switch.
7. Reinstall Switch Cover Plate and screws, with warning label facing out.

## Power Supply Cord Replacement

1. Remove Cover Plate and screws (#55 & #56). See pg. 20.
2. Disconnect the Power Supply Cord (#46) from; a) the Fuse Holders on #61, and, b) the green wire connected to the grounding screw (#42). Refer to the Electrical Schematic, Figure 3A.

3. Loosen the cord grip housing (#45) and remove the power cord (#46).
4. Install the new cord in reverse order of disassembly.
5. Install the cover and screws with warning label facing out.

## Replacement of Motor Starter

1. Remove Cover Plate and screws (#55 & #56). See pg. 20.
2. Disconnect wires, a) the red wires from the pressure switch, b) the black wire from the motor and, c) the black wire from the On/Off Switch.
3. Remove screws (#58) and washer and nuts (#52 #53).
4. Replace Motor Starter and re-secure with screws, washer and nuts (#58, #53 and #52). Always use heat sink material on the back of the Motor Starter when installing.
5. Reconnect wires according to Figure 3A.
6. Reinstall switch cover and screws, with warning label facing out.

# TITAN

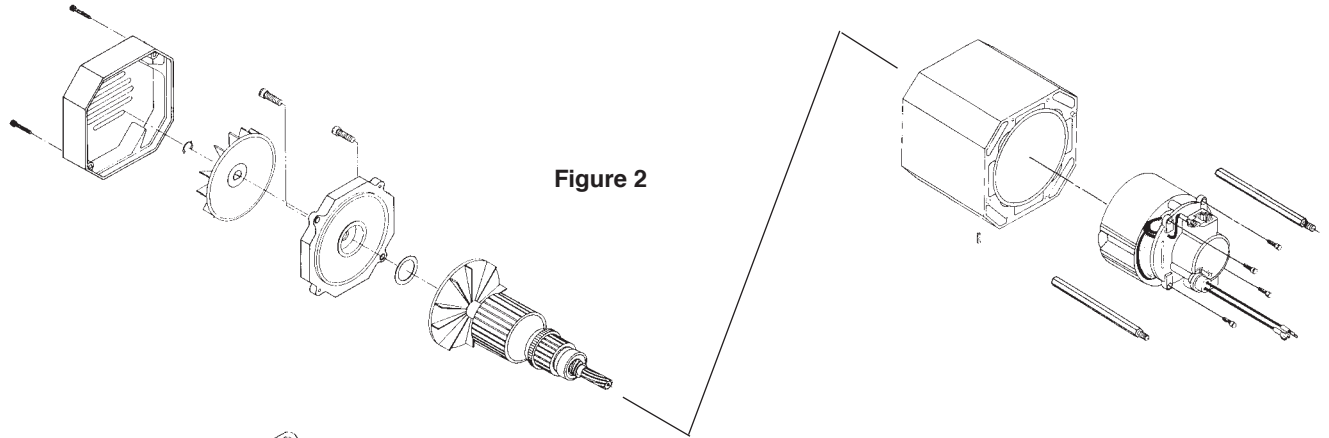

Figure 2

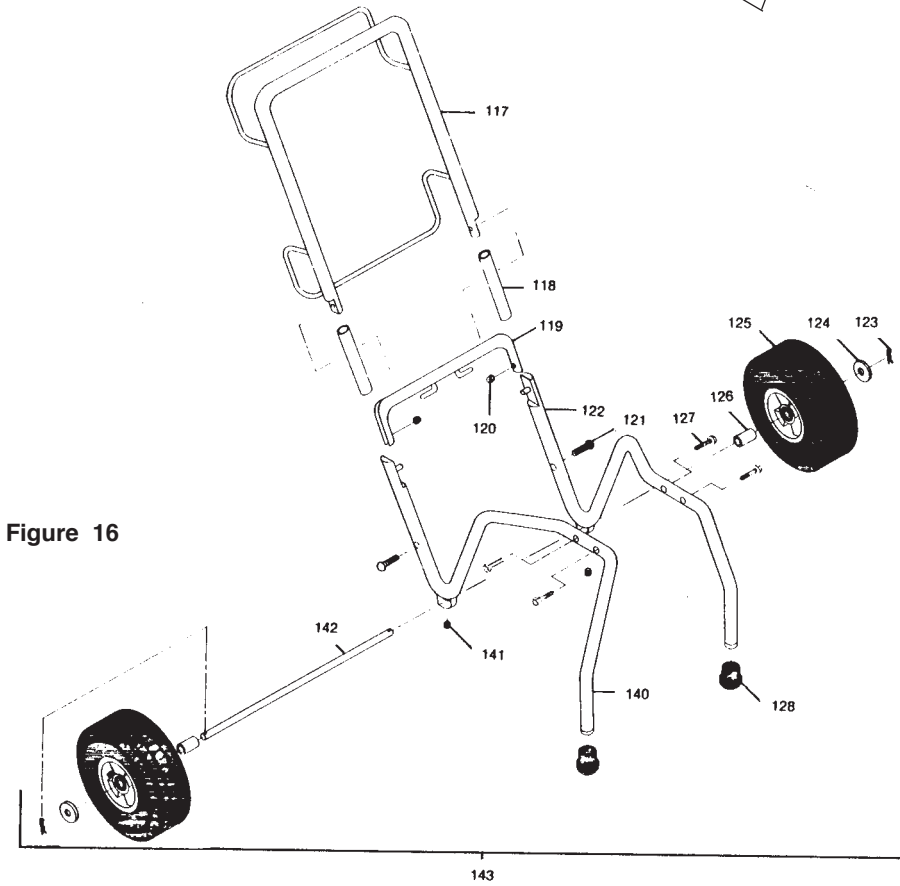
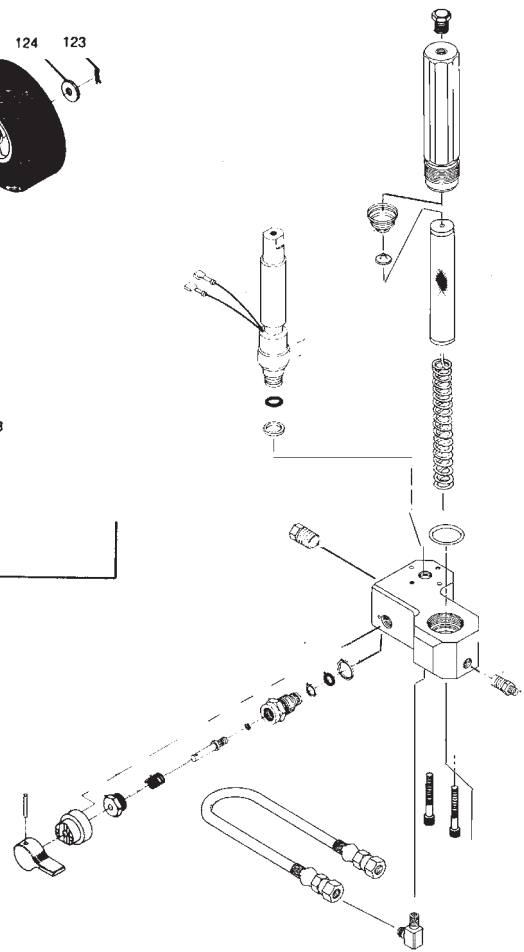

Figure 16



## Low Rider Frame Assembly

ITEM NO	PART NO	DESCRIPTION	QTY
117	702-057	Handle	1
118	730-101	Hinge Lock	2
119	702-116	Rear Cross Member	1
120	700-802	Cap Nut	2
121	700-801	1/4" Carriage Bolt	2
122	702-127	Main Frame Right	1
123	710-045	Pin Axle	2
124	710-058	Washer Axle	2
125	702-048	Wheel	2
126	702-087	Spacer	2
127	700-652	Bolt	4
128	710-047	Rubber Boot	2
140	702-126	Main Frame Left	1
141	710-051	Set Screw	2
142	702-061	Axle	1
143	702-060	"Low Rider" Frame	1



# Epic 660HPX

Replacement Labels		
PART NO	DESCRIPTION	QTY
700-418	Front Plate (Front Cover Label)	1
313-175	“Warning/Attention” Label in French	1
313-1205	Wraparound Label	1

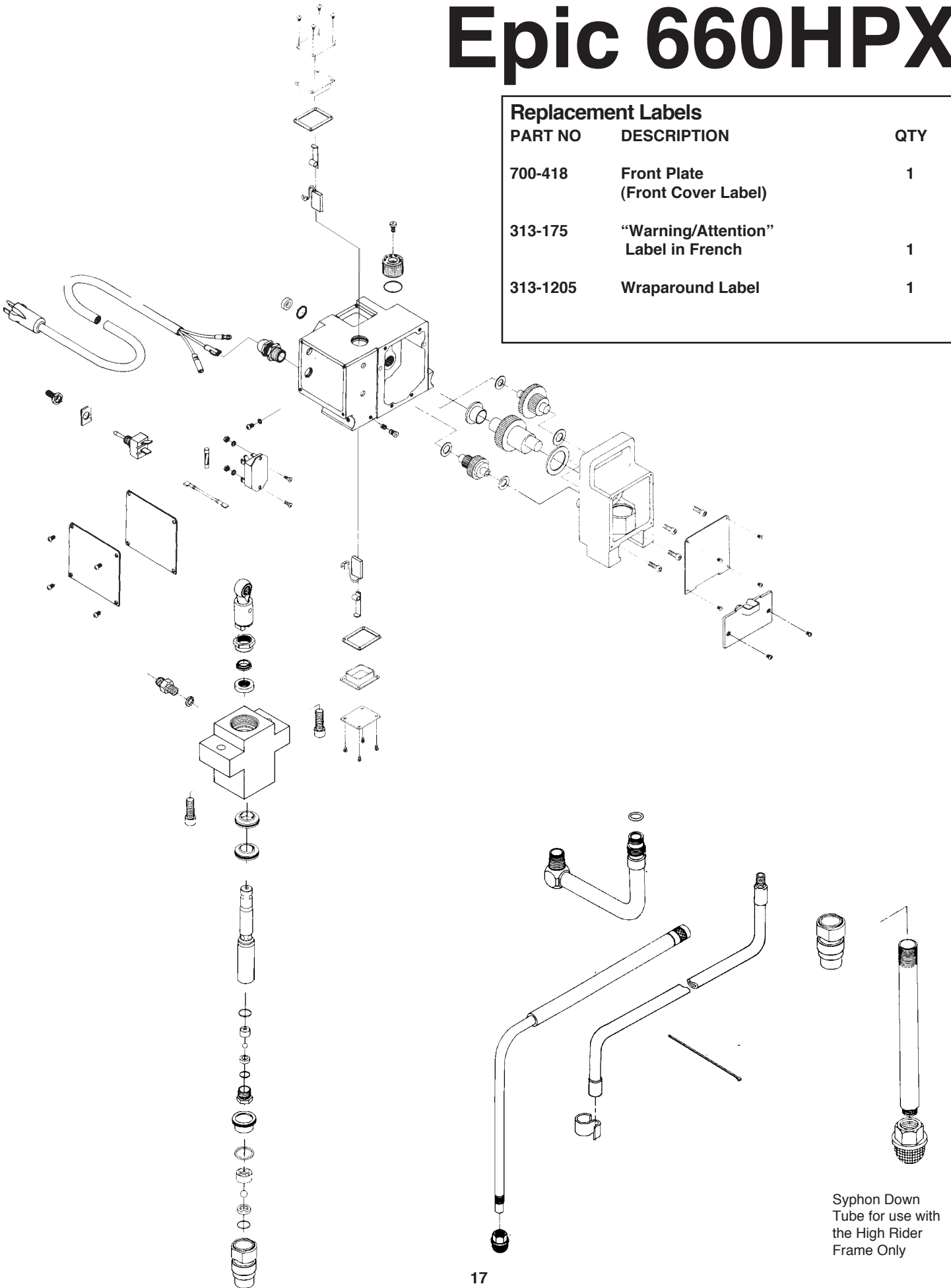

# Epic 660HPX

## UNITEC Motor Complete

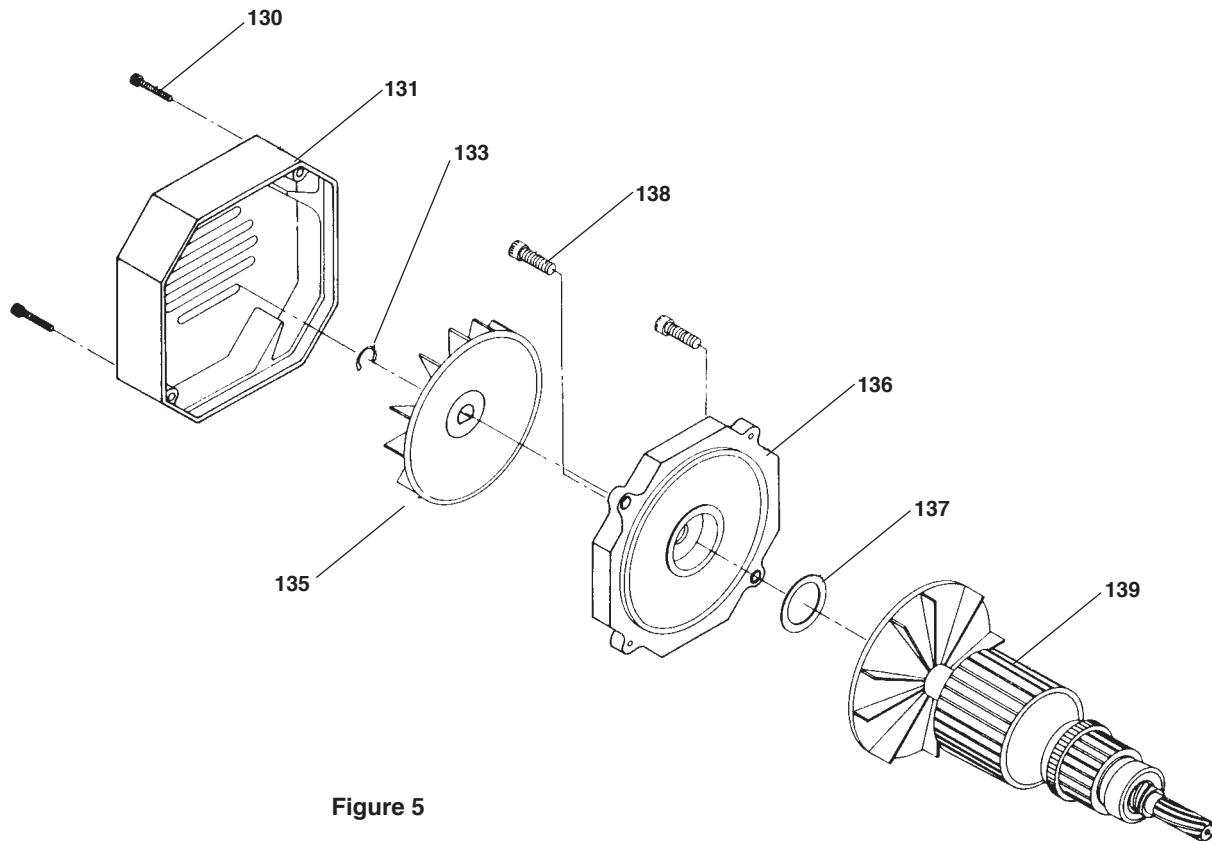

Figure 5

ITEM NO	PART NO	DESCRIPTION	QTY
130	761-023	Screw	2
131	702-046	Rear Cover	1
133	611-405	Snap Ring	1
135	702-040	Outer Fan	1
136	702-045	Rear Motor Housing	1
137	702-047	Wave Washer	1
138	700-681	Screw	2
*139	702-242	Armature 110V	1

\* **For 100 Volt Units:**

ITEM NO	PART NO	DESCRIPTION	QTY
139	702-241	Armature 100V	1

\* **For 230 Volt Units:**

ITEM NO	PART NO	DESCRIPTION	QTY
139	702-243	Armature 220V	1

## Armature Replacement

**WARNING:** Before proceeding, follow the Pressure Relief Procedure outlined on Page 5. Additionally, follow all other warnings to reduce the risk of an injection injury, injury from moving parts or electric shock. Always unplug the sprayer before servicing!

1. Remove Rear Cover (#131) by taking out screws (#130).
2. Remove Snap Ring (#133).
3. Remove Fan (#135).
4. Remove Rear Motor Housing (#136) by removing screws (#138). **NOTE:** Make sure to remove Wave Washer (#137) which should be on the End Bearing of the Armature.
5. Remove Motor Brushes. Follow Brush replacement procedure located on page 21.
6. Remove Armature by gently rocking and pulling Fan from rear of pump.
7. Inspect Armature. If damaged, replace.
8. To replace Armature, reverse steps 1 through 6 here.

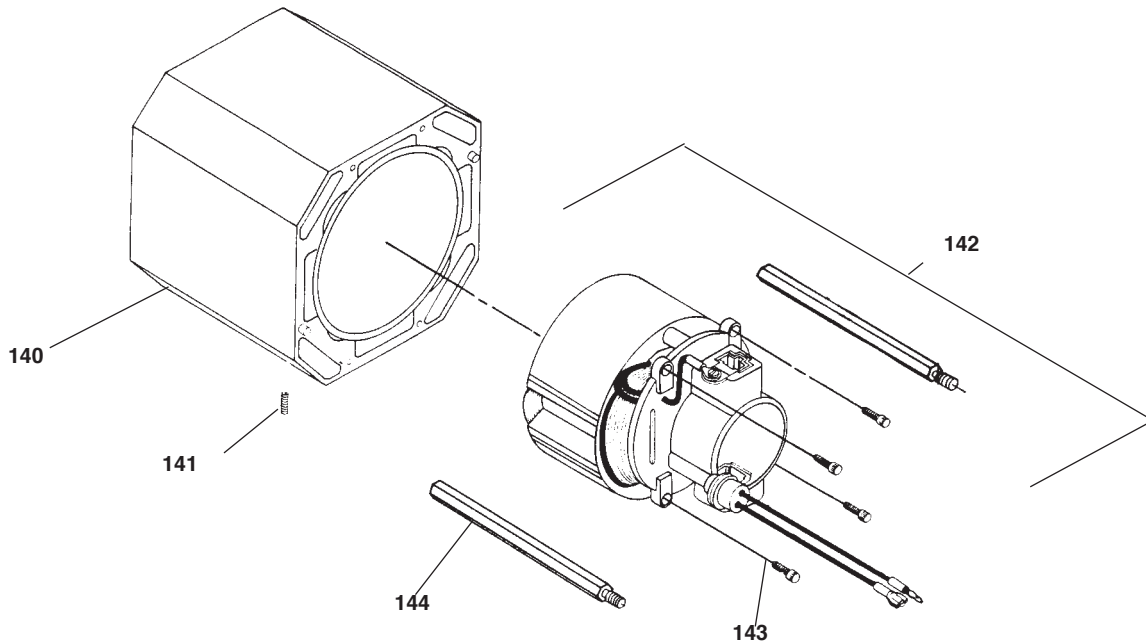

Figure 6

ITEM NO	PART NO	DESCRIPTION	QTY
140	702-404	Outer Housing (Excludes 141)	1
141	761-244	Screw	1
142	702-084	Motor Field (Excludes 143, 144)	1
143	700-639	Screws	4
144	702-056	Mounting Stud	2

## Motor Housing Replacement

**WARNING:** Before proceeding, follow the Pressure Relief Procedure outlined on Page 5. Additionally, follow all other warnings to reduce the risk of an injection injury, injury from moving parts or electric shock. Always unplug the sprayer before servicing!

1. Follow steps 1 through 6 in Armature Replacement.
2. Remove Switch cover plate (#56) and Insulator Plate (#55) located on Page 20.
3. Disconnect black wire from Post (#2) of Motor Starter (#54).
4. Disconnect black wire from Motor to white wire from Power Cord.
5. Remove outer Motor Housing (#140).
6. Loosen set screw (#141) and push Motor Field Assembly (#142) out from the back of the outer Motor Housing (#140).
7. Inspect Motor Field Assembly (#142). If damaged, replace.
8. To install Motor Housing, reverse steps 1 through 6 here and steps 1 through 7 of the Armature Replacement.

### For 100 Volt Units:

ITEM NO	PART NO	DESCRIPTION	QTY
142	702-211	Motor Field Assembly 100V	1

### For 230 Volt Units:

ITEM NO	PART NO	DESCRIPTION	QTY
142	702-137	Motor Field Assembly 230V	1

# Epic 660HPX

## Gear Box

See Figure 7 for the Wiring Diagram.

See page 15 for 230V Service Instructions

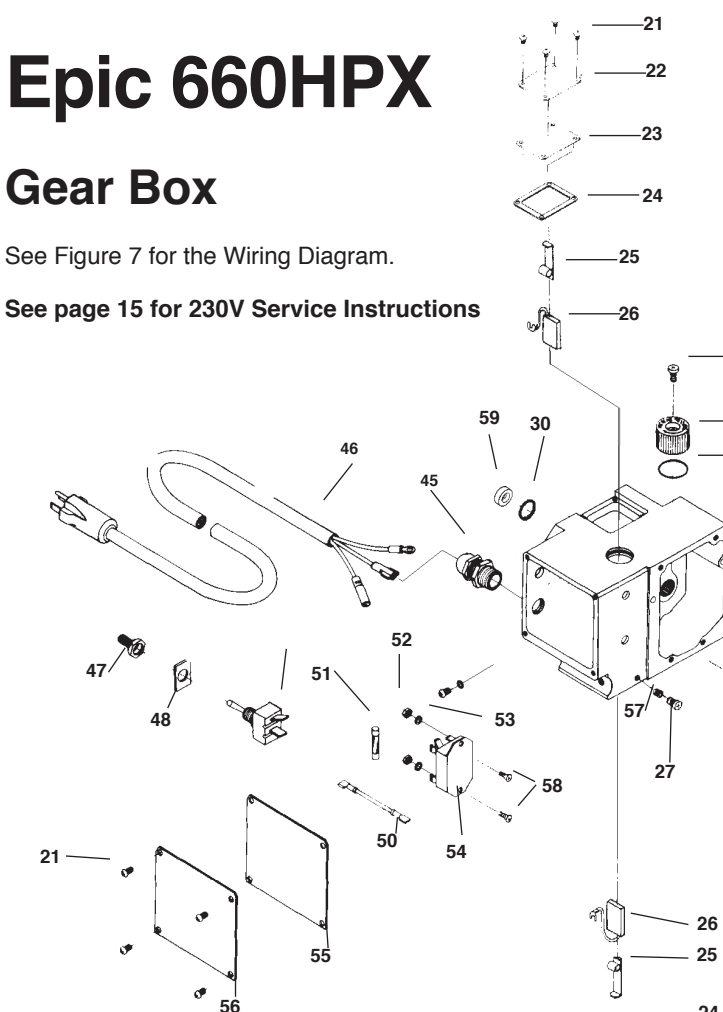

Figure 9

ITEM NO	PART NO	DESCRIPTION	QTY
21	730-260	Screw	19
22	702-053	Brush Plate	2
23	702-039	Brush Insulator	2
24	765-047	Brush Gasket	2
25	702-067	Brush Spring	2
26	702-066	Brush	2
27	700-784	Screw	2
28	700-771	Adjustment Knob	1
29	700-811	O-Ring	1
30	702-079	Oil Seal (#028 O-Ring)	1
31	702-300	Motor Housing (Incl. #29, 30, 59)	1
32	700-688	Thrust Washer	1
33	730-167	Output Pinion Gear Assy.	1
34	700-514	Thrust Washer	1
35	730-088	Thrust Washer	1
36	700-688	Thrust Washer	2
37	730-360	Crankshaft	1
38	702-073	Pinion Gear	1
39	700-680	Thrust Washer	1
40	702-076	Pump Housing Assembly	1
41	700-681	Screw	4
43	700-791	Safety Plate	1
44	700-418	Front Plate	1

## 120V Electrical Schematic

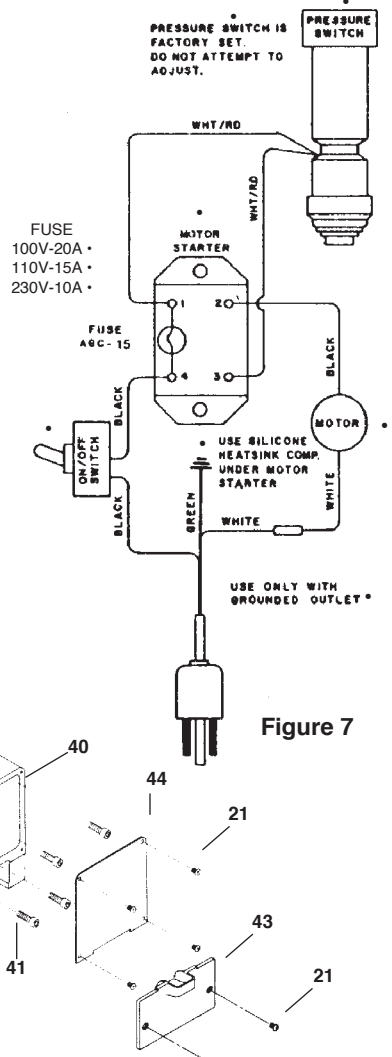

Figure 7

ITEM NO	PART NO	DESCRIPTION	QTY
45	765-063	Cord Grip Assembly	1
46*	765-054	Power Cord	1
47*	700-645	Rubber Boot	1
48*	700-775	On/Off Plate	1
49*	700-646	Toggle Switch	1
50	765-072	Wire, Switch to Starter	1
51*	700-895	Fuse 15 Amp	1
52	700-714	Nut	2
53	700-785	Lock Washer	3
54*	700-657	Motor Starter	1
55	761-192	Insulator Plate	1
56	761-132	Switch Cover Plate	1
57	700-715	Set Screw	1
58	700-713	Screw	2
59	702-014	Grease Seal	1

### For 230Volt Units:

ITEM NO	PART NO	DESCRIPTION	QTY
46*	761-725	Power Cord	1
48	770-593	On/Off Plate	1
49	765-083	Toggle Switch	1
50	765-072	Wire	3
51*	700-720	230V Fuse 10 Amp	2
54*	765-050	Motor Starter	1
	313-098	Earth Symbol Label	1
60	765-087	Lock Nut	1
61	765-089	Fuse Block Assembly	1

### For 100V Units

51	710-050	Fuse 20 Amp	1
----	---------	-------------	---

## Gear Replacement

**WARNING:** Before proceeding, follow the Pressure Relief Procedure outlined on Page 5. Additionally, follow all other warnings to reduce the risk of an injection injury, injury from moving parts or electric shock. Always unplug the sprayer before servicing!

1. Remove safety plate (#43).
2. Remove screws (#21) with a 3/16" allen wrench.
3. Slide pump section from crank slide (#300) pg. 24. If pump section will not slide off, use a screwdriver to pry pump section down, then slide off.
4. Remove cover (#44).
5. Remove (4) screws #21 with a 3/16" allen wrench.
6. Slide pump housing main assembly (#40) off motor box housing #31.
7. Inspect gears beginning with crankshaft assembly(#37). Then, output pinion gear (#33), followed by pinion gear (#38).
8. Inspect pinion gear on motor armature assembly (#139) pg. 18 by removing motor as described in motor replacement section.
9. Reassemble by reversing the above order. When reassembling, make sure that all washers are in place and that gears and bearing are properly lubricated.
10. Grease Item #37 every 100 hours. Fitting located under Plate #44.
11. Grease Item #300 on page 24 every 100 hours. Fitting located on Item #300 under Plate #44.

## On/Off Switch Replacement

**WARNING:** Before proceeding, follow the Pressure Relief Procedure outlined on Page 5. Additionally, follow all other warnings to reduce the risk of an injection injury, injury from moving parts or electric shock. Always unplug the sprayer before servicing!

1. Remove Switch Cover Plate and screws (#56 & #55).
2. Disconnect the two black wires from the On/Off Switch (#49).
3. Remove the rubber boot and plate (#47 & #48) with a wrench.
4. Remove the On/Off Switch (#49).
5. Install a new Switch and reattach plate and rubber boot. Tighten securely.
6. Reconnect the two black wires to the new On/Off Switch.
7. Reinstall Switch Cover Plate and screws, with warning label facing out.

## Power Supply Cord Replacement

**WARNING:** Before proceeding, follow the Pressure Relief Procedure outlined on Page 5. Additionally, follow all other warnings to reduce the risk of an injection injury, injury from moving parts or electric shock. Always unplug the sprayer before servicing!

1. Remove Switch Cover Plate and screws (#55 & #56).
2. Disconnect the Power Supply Cord (#46) from; a) the On/Off Switch (#49), b) the white wire connected to the motor and, c) the green wire connected to the grounding screw (#42). Refer to the Electrical Schematic, Figure 7.
3. Loosen the cord grip housing (#45) and remove the power cord (#46).
4. Install the new cord in reverse order of disassembly.
5. Install the cover and screws with warning label facing out.

## Replacement of Motor Starter

**WARNING:** Before proceeding, follow the Pressure Relief Procedure outlined on Page 5. Additionally, follow all other warnings to reduce the risk of an injection injury, injury from moving parts or electric shock. Always unplug the sprayer before servicing!

1. Remove Switch Cover Plate and screws (#55 & #56).
2. Disconnect wires, a) both white/red wires from the pressure switch, b) the black wire from the motor and, c) the black wire from the On/Off Switch.
3. Remove screws (#58) and washer and nuts (#52 #53).
4. Replace Motor Starter and resecure with screws, washer and nuts (#58, #53 and #52). Always use heat sink material on the back of the Motor Starter when installing.
5. Reconnect wires according to Figure 7.
6. Reinstall switch cover and screws, with warning label facing out.

## Motor Brush Replacement

**WARNING:** Before proceeding, follow the Pressure Relief Procedure outlined on Page 5. Additionally, follow all other warnings to reduce the risk of an injection injury, injury from moving parts or electric shock. Always unplug the sprayer before servicing!

1. Remove Brush Plate (#22).
2. Remove Brush Insulator (#23).
3. Remove Brush Spring (#25). **NOTE:** To remove brush spring, push spring down and in for it to release.
4. Back-off screw. Hold Brush Wire and remove Brush.
5. Inspect Motor Brush. If damaged replace.
6. Repeat procedure for other brush.
7. To install Motor Brushes, reverse steps 1 through 6, **NOTE:** Never operate this unit without Brush Insulator and Brush Plate installed.

# Epic 660HPX

## Filter Block

ITEM NO	PART NO	DESCRIPTION	QTY
201	710-069	Plug	2
202	702-011	Maxi Filter HSG	1
203	730-083	Filter Spring	1
204	730-067	Filter Cartridge	1
205	757-105	Filter Spring	1
206	702-303	O-Ring	1
207	702-009	Filter HSG	1
210	702-251	Adapter	1
212	730-262	1/4-20 UN Screw	2
214	227-006	1/4" Nipple	1
215	700-537	Gasket	1
216	221-012	Backup Ring	1
217	222-012	O-Ring	1
218	700-246	Bypass Housing (includes #216 & #217)	1
219*	700-721	#005 O-Ring	1
220	700-250	Bypass Valve Stem	1
222	700-244	Spring	1
224	700-248	Bypass Valve Retainer	1
225	700-252	Bypass Cam Base	1
226	700-759	Dowel Pin	1
227	700-697	Bypass Valve Handle	1
230	700-258	Bypass Valve Assembly	1
231	702-250	Pressure Control (Includes #232 & #233)	1
232	700-499	O-Ring	1
233	700-881	Gasket	1
240	702-305	Filter HSG Assembly (Excludes Item #212, #231, #232, #233, #242)	1
241	490-106	Elbow	1
242	316-516	Hose	1
*	700-897	Optional PTFE O-Ring	1
**	700-890	Bypass O-Ring Tool	1

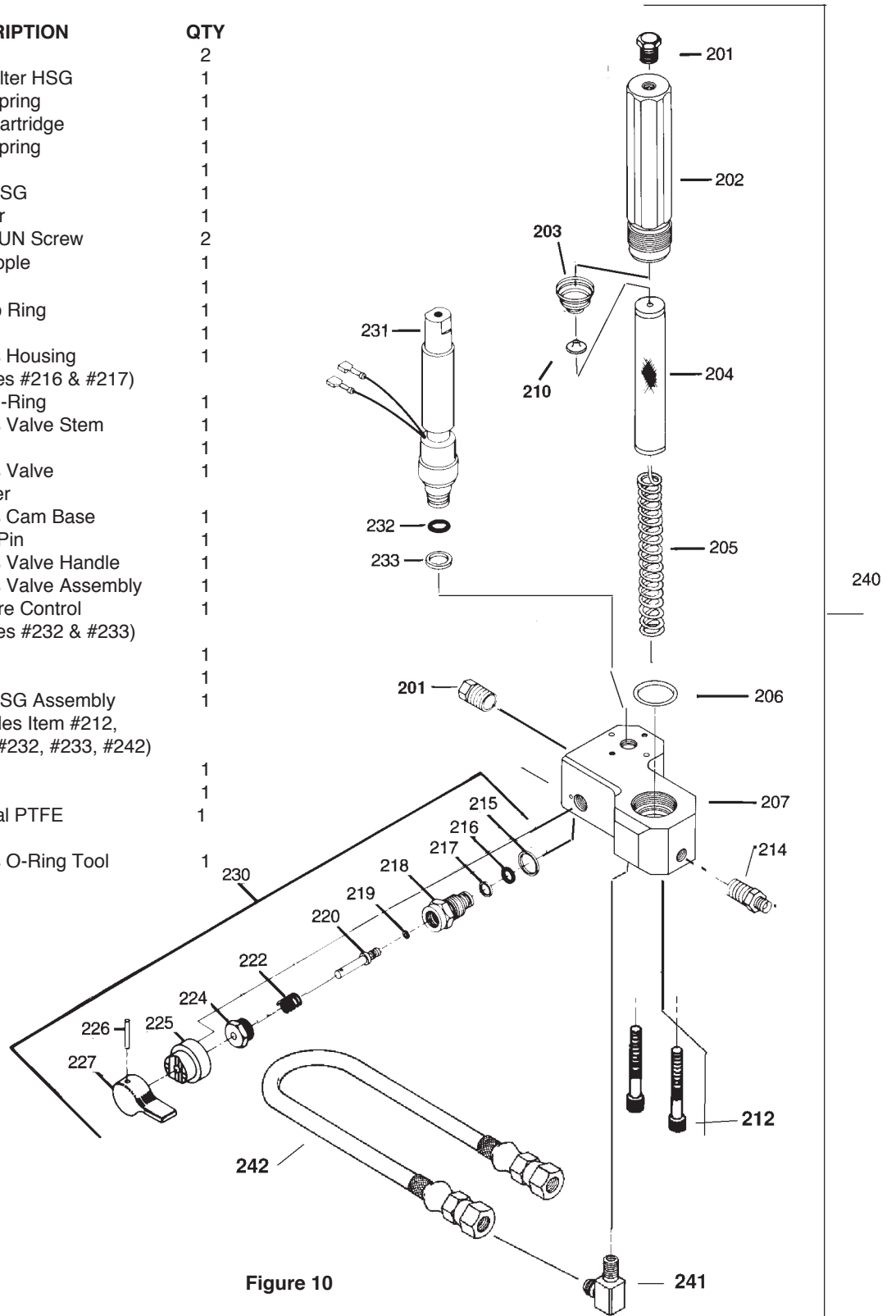

\*\*Supplied but not shown

Figure 10

## Pressure Switch Replacement

**WARNING:** Before proceeding, follow the Pressure Relief Procedure outlined on page 5. Additionally, follow all other warnings to reduce the risk of an injection injury, injury from moving parts or electric shock. Always unplug the sprayer before servicing!

1. Remove cap screws #212 from bottom of filter block.
2. Remove filter block #240.
3. Remove switch cover plate #56, located near pressure switch and disconnect two red wires from motor starter #54. See pg. 20.
4. Remove screw #27 from pressure switch adjustment knob and slide knob off. See pg. 20.
5. Remove screw #27 located on side of motor housing #31 and using a 1/8" allen wrench remove set screw #57, until pressure switch #231 is able to slide down through. Feed electrical wires down at the same time.
6. Insert new switch assembly #231 into housing while carefully working the wires into the switch box. Using needle nose pliers, reconnect wires to motor starter.
7. Making sure that the switch assembly is fully inserted, tighten set screw #57 with a 1/8" allen wrench until the switch assembly is secure. Reattach adjustment knob #28. See pg. 20
8. Inspect O-Rings #232 and 233 on switch assembly. If properly in place, then install filter block #240 by lining up dowels. Secure with screws #212.
9. Install insulator plate #55 switch plate #56. See pg. 20
10. The pressure switch is factory calibrated so no adjustment is required.

## Service/Replacement of the Pressure Relief Prime Valve

**WARNING:** Before proceeding, follow the Pressure Relief Procedure outlined on Page 5. Additionally, follow all other warnings to reduce the risk of an injection injury, injury from moving parts or electric shock. Always unplug the sprayer before servicing!

1. Remove the Groove Pin (#226) from Bypass Valve Handle (#227).
2. Remove Handle (#227) and Bypass Cam (#225).
3. Using a wrench, loosen Bypass Housing (#218) and unscrew.
4. Unscrew Bypass Retainer (#224) and remove Bypass Valve Stem (#220).
5. Inspect ball on end of Stem (#220) and O-Ring (#219). Clean or replace if worn.
6. Screw completed assembly into Filter Block except for items #225, 226 and 227. Tighten securely with wrench.
7. Install Bypass Cam (#225) over Bypass Retainer (#224), lubricate with grease. Line up Groove Pin on Cam (#225) with hole on Filter Block (#207).
8. Using Groove Pin (#226) line up Stem (#220) with hole on Handle (#227). Secure Handle with Groove Pin (#226).
9. IMPORTANT: If Handle (#227) rotates 360° check Pin on Cam (#225).

## Service / Replacement of Filter

**WARNING:** Before proceeding, follow the Pressure Relief Procedure outlined on Page 5. Additionally, follow all other warnings to reduce the risk of an injection injury, injury from moving parts or electric shock. Always unplug the sprayer before servicing!

### PUMP FILTER

1. Unscrew Filter Housing (#202).
2. Remove Filter Cartridge (#204). Clean or replace.
3. Inspect O-Ring (#206). Clean or replace.
4. Reattach Filter Housing (#202).

### Gun Filter

**WARNING:** Follow all safety precautions as described in high pressure warning section before proceeding. If your spray gun leaks or spits at the tip when you release the trigger, the needle or seat is dirty, worn or damaged and must be cleaned or replaced.

#### Replacement or Removal of Filter:

1. First pull down on trigger safety guard and swing away from handle.
2. Unscrew handle from spray head.
3. Unscrew left hand threaded\* filter from spray head. (\*NOTE: Left handed thread requires turning the filter clockwise to remove.)
4. Screw new or cleaned (†) filter into the head. To reinstall left hand thread turn counterclockwise.
5. Reattach handle to head and secure safety trigger guard. (NOTE: If filter breaks off in the head use a small wood screw to remove.)

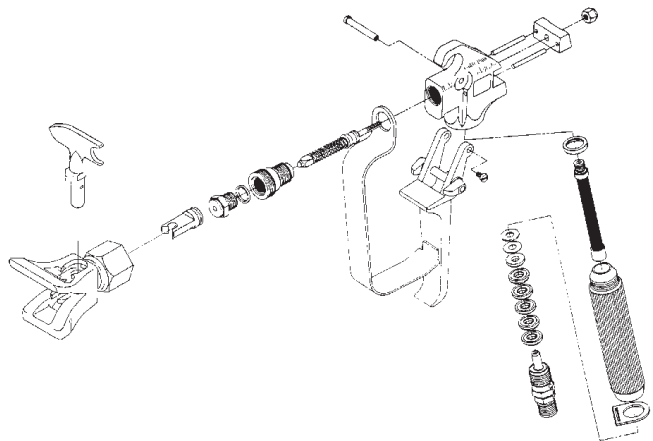

**Figure 19** -- (†)For more detail, part number information and assembly drawings at larger scale, please see the LX - 80 Professional Airless Gun Owner's Manual (#313-012).

# Fluid Section 660HPX

ITEM NO	PART NO	DESCRIPTION	QTY
300	700-735	Crank & Slide Connecting Rod Assy.	1
301	730-508	Retainer	1
302	700-587	Upper Guide	1
304	700-603	Upper Seal	1
305	730-505	Pump Housing	1
306	700-678	Head Cap Screw	2
307	700-601	Lower Seal	2
308	730-506	Piston Rod	1
309	762-111	Seal	1
310	762-135	Upper Cage	1
311	762-144	Outlet Valve Ball	1
312	762-073	Outlet Valve Housing	1
313	762-134	Seat	1
314	762-057	O-Ring	1
315	730-515	Piston Assembly	1
317	730-509	Bushing	1
318	700-821	Seal	1
319	730-510	Cage	1
320	762-145	Ball	1
321	762-137	Inlet Valve Seat	1
322	762-058	O-Ring	1
323	730-507	Foot Valve Housing	1
325	730-520	Foot Valve Assembly	1
347	762-202	Packing Tool	1
331	700-211	Pump Syphon Tube	1
332*	700-201	O-Ring (Viton)	1
335	700 213	Pump Syphon Tube Assy.	1
	730-401	Repacking Kit: Includes #302, 304, 307, 311, 318, 309, 320 (700-203 Packing Grease and 700-793 Piston Guide Tool also included)	1
391	700-804	Gasket	1
392	490-109	Fitting	1
350	730-501	Fluid Section Complete (#301-305, 307-323)	1

\* 700-024 Optional Urethane O-Ring 1

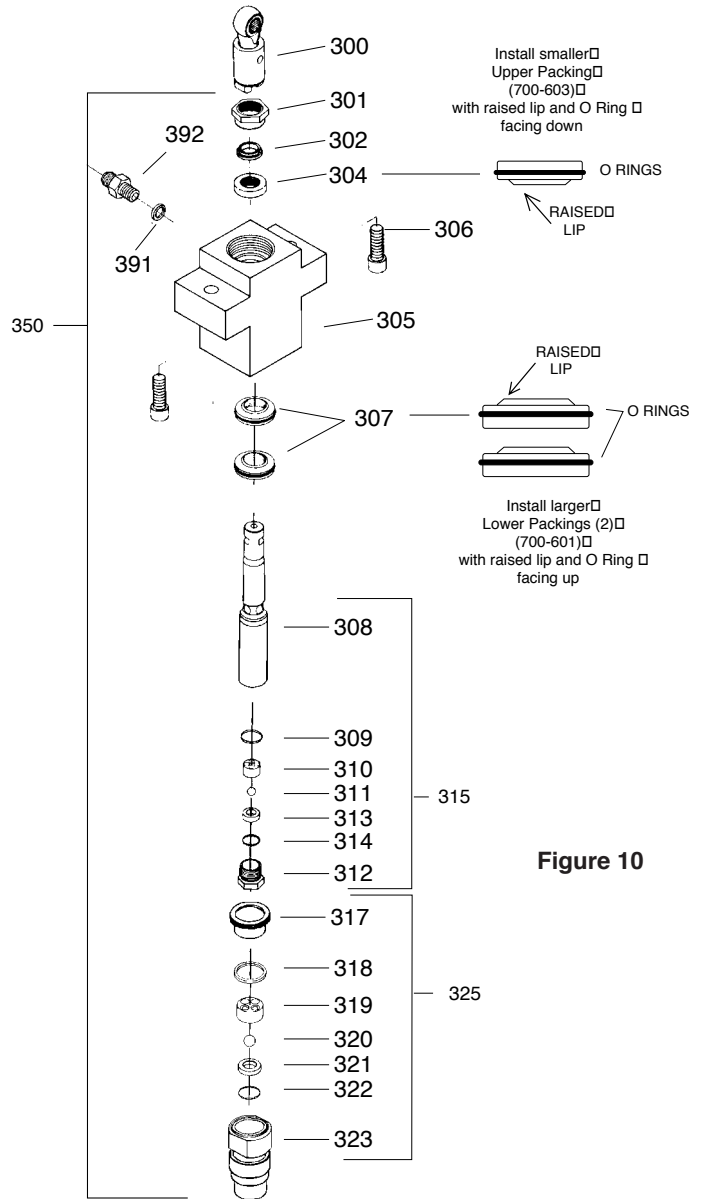
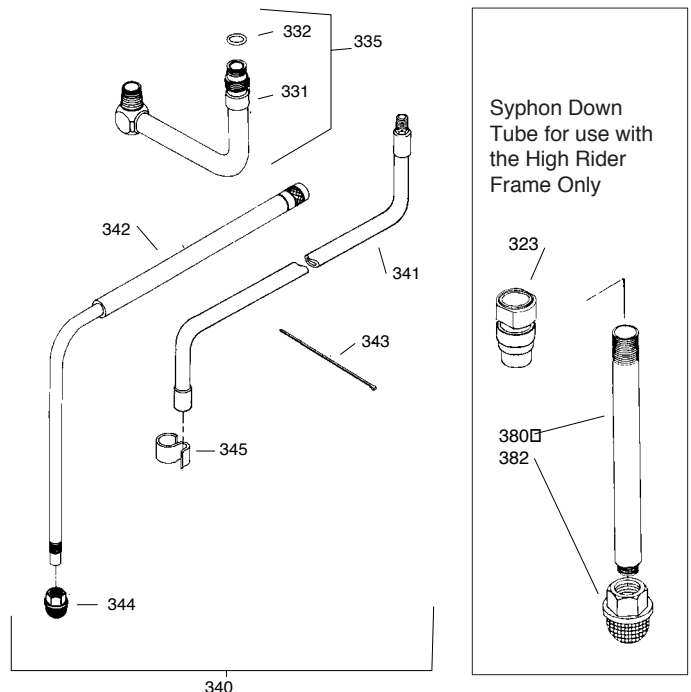

Figure 10

# Syphon Assembly

ITEM NO	PART NO	DESCRIPTION	QTY
340	700-206	Syphon Tube Assembly (#345)	1
341	700-847	Bypass Assembly	1
342	700-204	Syphon Assembly (Includes #341, 345)	1
343	700-742	Hose Tie Wrap	1
344	700-805	Inlet Screen	1
	700-900	Optional 30 Mesh Inlet Screen	1
345	700-212	Clip	1
		For High Rider	
380	710-018	Syphon Down Tube	1
382	710-046	Inlet Assembly	1
	710-191	30 Mesh Screen	1
323	730-511	Housing	1
341	702-239	Bypass Assembly	1
	755-109	Pail Hook	1
	730-334	Clip Down Tube	1
	765-142	Safety Plate	1
350	730-502	Fluid Section Complete (Excludes 391, 392)	1





# Pump Section Repair and Service

**WARNING:** Before proceeding, follow the Pressure Relief Procedure outlined on page 5. Additionally, follow all other warnings to reduce the risk of an injection injury, injury from moving parts or electric shock. Always unplug the sprayer before servicing!

1. Remove Safety Plate (#43). Figure 9.
2. Stop the sprayer at the top of its stroke so that the piston is in its highest position. Turn off and/or unplug the sprayer.
3. Remove the bypass hose assembly (#341) with a wrench and **the syphon assembly (#342) by pulling up on the hose and turn counterclockwise.**
4. Tilt pump back for easy access to pump section.

## SEAT SERVICE & REPAIR

The design of Titan's Epic Fluid Section allows access to the inlet and outlet valves and seat without completely disassembling the Fluid Section. It is possible that the valves may not seat properly because of debris stuck in the inlet or outlet seat. Follow the instructions below for access to those areas.

5. Place a wrench on the Foot Valve (#323) and unthread.
6. Clean out all debris. Examine Valve and Seat. If damaged replace. Continue if necessary or reinstall.
7. Place a 3/4" socket on the Outlet Valve Housing and Seat (#312) and remove.
8. Clean out all debris. Examine Valve and Seat. If damaged, reverse or replace.
9. Reassemble and test unit. Should unit not perform properly consult the Troubleshooting Guides on pages 13 & 14 of this manual or continue with the Repair and Packing Replacement instructions below.

## SERVICE/REPLACEMENT OF UPPER (OUTLET) VALVE

10. To clean or replace upper valve, remove Valve Housing (#312) while piston assembly (#315) is still attached to pump. This will prevent the piston from rotating.
11. Remove upper valve case (#310) and Outlet Valve Seat (#313) & Ball (#311). Clean and inspect along with Housing (#312). Replace if worn or damaged. Use fine sandpaper to remove dried paint.
12. Reattach assemblies (#309-#312) to piston #308, and secure tightly with a wrench.

## PACKING REPLACEMENT

13. Remove Outlet Mounting Bolt (#263) from rear of pump. (As shown in Figure 8, page 22.)
14. Remove screws #306 with a 3/8" allen wrench and slide pump section down so that the piston is clear to slide off.
15. Inspect gasket (#391) on fitting after removing pump section. Clean or Replace.
16. Remove Retainer (#301) and slide piston down through pump mount assembly (#305) by lightly tapping on top of piston assembly (#315). Clean and inspect piston for wear. Replace if necessary.
17. Remove packings (#304 & #307) from pump housing (#305), and replace with a new set. **Always insert packings with the raised side facing into pump mount assembly.**
18. Reattach Retainer (#301) and make sure that the upper guide (#302) is cleaned and undamaged.
19. Insert pump housing assembly (#301, #307) into a vise, leaving enough room to slide piston through bottom of pump housing (#305).
20. Using the piston guide tool (#346) (included in repacking kit) which slides over the top of the piston assembly (#315), insert the piston through bottom of pump housing (#305) and tap lightly with a rubber mallet on bottom of piston until inserted.
21. Align flats on piston so that it is perpendicular to housing (#305) and will line up when reattaching to connecting rod. This can be achieved by rotating the piston by placing a wrench on the valve housing assembly (#312) and turning.

**IMPORTANT: NEVER USE A WRENCH ON THE PISTON ITSELF. THIS COULD CAUSE DAMAGE TO THE PISTON AND CAUSE LEAKAGE.**

22. Slide assembled pump housing with piston assembly onto connecting rod and secure with screws #306. Be certain that outlet hole is facing towards pump motor (#207). NOTE: Packing does not need to be adjusted.
23. Reattach hose (#242) to fitting (#392) Be sure that polyethylene gasket (#391) is in place. (See Filter Block p. 22)
24. Reattach lower foot valve assembly (#325)
25. Reattach pump syphon tube assembly (#335), and rotate to correct position.
26. Reattach pressure relief tube and syphon hose and tighten securely.

**NOTE: Repacking Kit (730-401) is available. For best results use all parts supplied in this kit.**

MODEL #	SERIAL #	DATE PURCHASED	COMPANY NAME
---------	----------	----------------	--------------

## Equipment Job History

In order to help you track the superior performance of your Titan Sprayer we recommend you keep this log for your records. We feel you may find it useful for gauging on-site performance, invoicing or overtime and your estimator's reference.

Job Name	Foreman's Name	Type of Coating	Tips Used		Date Completed
Date Begun	Site	Gallons Sprayed	Sizes	Quantity	
Job Name	Foreman's Name	Type of Coating	Tips Used		Date Completed
Date Begun	Site	Gallons Sprayed	Sizes	Quantity	
Job Name	Foreman's Name	Type of Coating	Tips Used		Date Completed
Date Begun	Site	Gallons Sprayed	Sizes	Quantity	
Job Name	Foreman's Name	Type of Coating	Tips Used		Date Completed
Date Begun	Site	Gallons Sprayed	Sizes	Quantity	
Job Name	Foreman's Name	Type of Coating	Tips Used		Date Completed
Date Begun	Site	Gallons Sprayed	Sizes	Quantity	
Job Name	Foreman's Name	Type of Coating	Tips Used		Date Completed
Date Begun	Site	Gallons Sprayed	Sizes	Quantity	
Job Name	Foreman's Name	Type of Coating	Tips Used		Date Completed
Date Begun	Site	Gallons Sprayed	Sizes	Quantity	
Job Name	Foreman's Name	Type of Coating	Tips Used		Date Completed
Date Begun	Site	Gallons Sprayed	Sizes	Quantity	
Job Name	Foreman's Name	Type of Coating	Tips Used		Date Completed
Date Begun	Site	Gallons Sprayed	Sizes	Quantity	
Job Name	Foreman's Name	Type of Coating	Tips Used		Date Completed
Date Begun	Site	Gallons Sprayed	Sizes	Quantity	
Job Name	Foreman's Name	Type of Coating	Tips Used		Date Completed
Date Begun	Site	Gallons Sprayed	Sizes	Quantity	
Job Name	Foreman's Name	Type of Coating	Tips Used		Date Completed
Date Begun	Site	Gallons Sprayed	Sizes	Quantity	
Job Name	Foreman's Name	Type of Coating	Tips Used		Date Completed
Date Begun	Site	Gallons Sprayed	Sizes	Quantity	

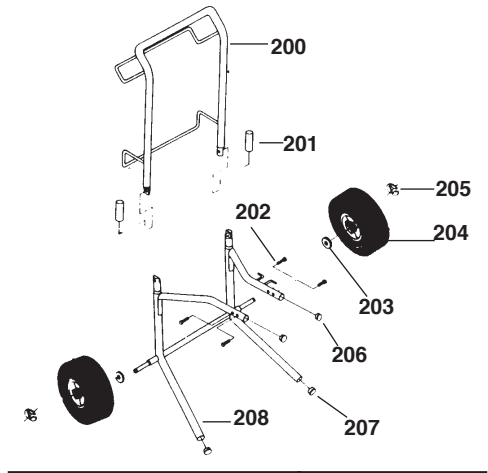

Figure 14 211

### High Rider Frame Assembly

ITEM NO	PART NO	DESCRIPTION	QTY
200	702-121	Handle	1
201	710-020	Hinge Lock	2
202	700-652	Bolt	4
203	710-058	Axle Washer	2
204	710-044	10" Wheel	2
205	710-194	Snap Ring	2
206	710-199	Leg Plug	2
207	710-198	Brace Plug	2
208	702-141	Main Frame (Incl. 206-10)	1
*209	700-761	Cord Holder	1
*210	700-069	Screw	2
211	702-125	High Rider Frame Complete	1

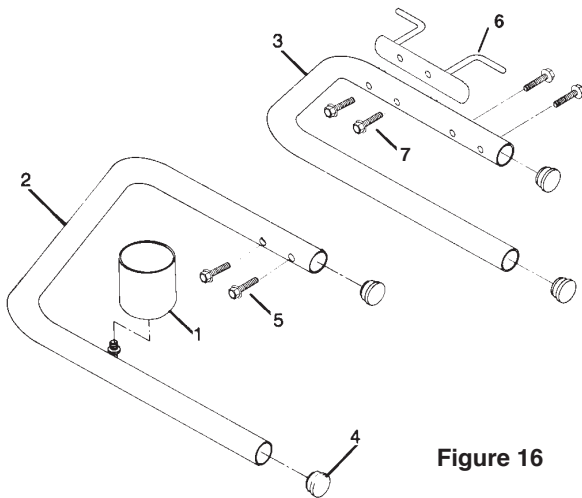

Figure 16

### Skid Frame Assembly

ITEM NO	PART NO	DESCRIPTION	QTY
1	700-781	Drip Cup	1
2	700-672	Frame (RT)	1
3	700-671	Frame (L)	1
4	700-674	Caps	4
5	700-652	Carriage Bolts	4
6	700-761	Cord Holder	1
7	700-069	Screw	2

\*Not shown

### 115V DOMESTIC PUMPS

702-405	660HPX Pump Only With low rider frame
702-410	660HPX Pump Complete With low rider frame
702-420	660HPX Pump Only With high rider frame
702-425	660HPX Pump Complete With high rider frame
702-43 5	660HPX Pump Only With skid frame

### 100V EXPORT PUMPS

702-212	660HPX Pump Only With low rider frame
702-213	660HPX Pump Only With high rider frame

### 115V EXPORT PUMPS

702-143-CE	660HPX Pump Complete With skid frame
702-098-CE	660HPX Pump Only With low rider frame
702-100-CE	660HPX Pump Complete With low rider frame
702-107-CE	660HPX Pump Complete With high rider frame

### 230V EXPORT PUMPS

702-133-CE	660HPX Pump Only With skid frame
702-102-CE	660HPX Pump Only With low rider frame
702-104-CE	660HPX Pump Complete With low rider frame
702-103-CE	660HPX Pump Only With high rider frame
702-105-CE	660HPX Pump Complete With high rider frame
702-174-CE	660HPX Pump Only With low rider frame & old syphon

PUMP	OPERATING PRESSURE	MAXIMUM TIP SIZE	WEIGHT	AMP DRAW MAX psi	MAXIMUM GPM OUTPUT	MAXIMUM HOSE LENGTH**	POWER SOURCE	PRODUCT NUMBER PUMP ONLY	PRODUCT NO. COMPLETE (with 50' Hose & LX-80 Gun)
<b>DP-30</b>	0-3000 psi	.017 w/1 gun	37 lbs	8	.33	100 ft	1/2 HP totally enclosed AC motor	703-095	703-100
<b>440HP</b>	0-3200 psi	.021 w/1 gun	27 lbs	9	.44	100 ft	3/4 hp AC motor	700-155	700-135
<b>447HPX</b>	0-3200 psi	.023 w/1 gun	33 lbs	11	.55	150 ft	.85 HP totally enclosed AC motor	765-100	765-110
<b>660HPX</b>	0-3200 psi	.025 w/1 gun	56 lbs	15	.72	200 ft	1.0 HP totally enclosed AC motor	702-405	702-410
<b>690HPG</b>	0-3200 psi	.025 w/1 gun	78 lbs	-	.80	250 ft	4.0 HP Honda engine	755-095	755-100
<b>1100HPX</b>	0-3200 psi	.031 w/1 gun .021 w/2 guns	90 lbs	15	1.0	300 ft	1.75 HP totally enclosed AC motor	781-101 (120v) HR 781-105-CE (230v) HR 781-103 (120v) LR 781-107-CE (230v) LR	781-100 (120v) HR 781-104-CE (230v) HR 781-102 (120v) LR 781-106-CE (230v) LR
<b>1200HPG</b>	0-3200 psi	.035 w/1 gun .025 w/2 guns .019 w/3 guns	125 lbs		1.35	300 ft	5.5 HP Honda engine	783-101 HR 783-111 LR	783-100 HR 783-110 LR

\*\* Hose length depends on material being sprayed, hose diameter and tip size.

\*\*\* DP-30 supplied with 25' of hose and a Profit Gun.

## TITAN WARRANTY FOR THE 660HPX

Titan Tool, Inc., ("Titan") warrants that at the time of delivery to the original purchaser for use ("End User"), the equipment covered by this warranty is free from defects in material and workmanship. Titan's obligation under this warranty is limited to replacing or repairing without charge those parts which, to Titan's reasonable satisfaction, are shown to be defective within twelve (12) months with the exception of defects in the parts of the pressure control and the drive train/gear box assemblies which will be repaired or replaced for twenty-four (24) months, and the electric motor (excluding brush replacement) which will be repaired or replaced for thirty-six (36) months, all after sale to the End User. This warranty applies only when the unit is installed and operated in accordance with the recommendations and instructions of Titan.

This warranty does not apply in the case of damage or wear caused by abrasion, corrosion or misuse, negligence, accident, faulty installation, substitution of non-Titan component parts, or tampering with the unit in a manner to impair normal operation.

Defective parts are to be returned to an authorized Titan sales/service outlet. All transportation charges, including return to the factory, if necessary, are to be borne and prepaid by the End User. Repaired or replaced equipment will be returned to the End User transportation prepaid.

THERE IS NO OTHER EXPRESS WARRANTY. TITAN HEREBY DISCLAIMS ANY AND ALL IMPLIED WARRANTIES INCLUDING, BUT NOT LIMITED TO, THOSE OF MERCHANTABILITY AND FITNESS FOR A PARTICULAR PURPOSE, TO THE EXTENT PERMITTED BY LAW. THE DURATION OF ANY IMPLIED WARRANTIES WHICH CANNOT BE DISCLAIMED IS LIMITED TO THE TIME PERIOD SPECIFIED IN THE EXPRESS WARRANTY. IN NO CASE SHALL TITAN LIABILITY EXCEED THE AMOUNT OF THE PURCHASE PRICE. LIABILITY FOR CONSEQUENTIAL, INCIDENTAL OR SPECIAL DAMAGES UNDER ANY AND ALL WARRANTIES IS EXCLUDED TO THE EXTENT PERMITTED BY LAW.

TITAN MAKES NO WARRANTY AND DISCLAIMS ALL IMPLIED WARRANTIES OF MERCHANTABILITY AND FITNESS FOR A PARTICULAR PURPOSE WITH RESPECT TO ACCESSORIES, EQUIPMENT, MATERIALS OR COMPONENTS SOLD BUT NOT MANUFACTURED BY TITAN. THOSE ITEMS SOLD, BUT NOT MANUFACTURED BY TITAN (SUCH AS GAS ENGINES, SWITCHES, HOSES, ETC.) ARE SUBJECT TO THE WARRANTY, IF ANY, OF THEIR MANUFACTURER. TITAN WILL PROVIDE THE PURCHASER WITH REASONABLE ASSISTANCE IN MAKING ANY CLAIM FOR BREACH OF THESE WARRANTIES.

**TITAN**  
TOOL INC.  
**TITAN Speedflo**



National Sales & Service

1-800-526-5362

Fax 1-800-528-4826

556 Commerce Street  
Franklin Lakes, NJ 07417

Canadian Branch

1-800-565-8665

Fax 1-905-856-8496

200 Towers Road, Unit 7B  
Woodbridge, Ontario L4L 5Z8

International

1-201-405-7520

Fax 1-201-405-7449

556 Commerce Street  
Franklin Lakes, NJ 07417 USA

© 1998 Titan Tool Inc.  
313-1229 Printed in the U.S.A.  
REV 0498

Titan and Speedflo are registered trademarks and Epic is a trademark of Titan Tool Inc.