

# INSTRUCTIONS-REPAIR



# 308922

Rev. B  
Supersedes Rev. A



**KEEP FOR REFERENCE.**  
Read this and all related manuals for important warnings and instructions.

INSTRUCTIONS

First choice when  
quality counts.™

## 495st Airless Paint Sprayers

3000 psi (210 bar, 21 MPa ) Maximum Working Pressure

120 VAC, 60 Hz

Model	Series	Description
231584	A	Standard mount; Contractor FTx gun, RAC IV tip & hose
231818	A	Standard mount; Contractor ST gun, RAC IV tip & hose
231585	A	Low profile cart; Contractor FTx gun, RAC IV tip & hose
232676	A	Upright cart; Contractor FTx gun, RAC IV tip & hose
232677	A	Upright cart
231819	A	Upright cart; Contractor ST gun, RAC IV tip & hose

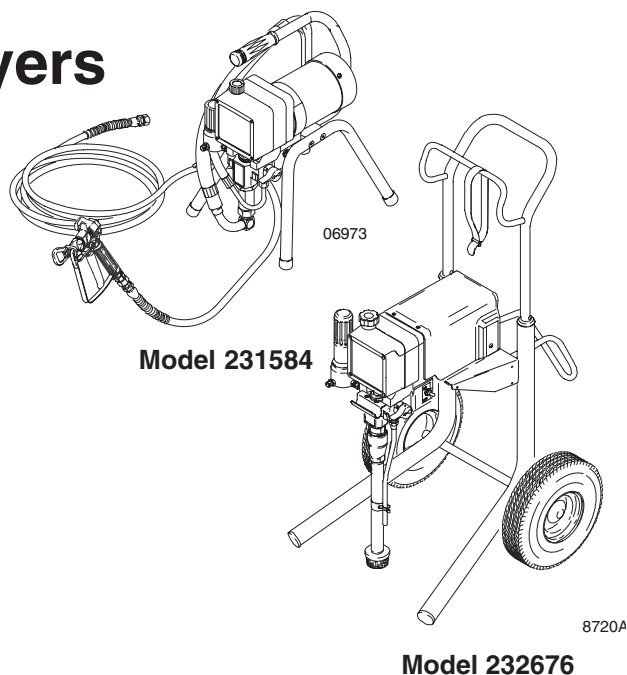

All models are not available in all countries

U.S. PATENT NO. 4,323,741; 4,397,610 P ATENTED  
1983, CANADA AND OTHER PATENTS PENDING

### Related Manuals

Operator .....	308921
Displacement Pump .....	308190
FTx Spray Gun .....	308645
ST Spray Gun .....	308664
Spray Tip .....	308644

## Table of Contents

Component Function and Identification .....	2	Drive Housing, Connecting Rod, Crankshaft .....	15
General Repair Information .....	3	Pressure Control .....	17
Grounding .....	4	Pressure Transducer .....	18
Troubleshooting .....	5	Suction Hose .....	18
Motor Test .....	9	Drain Valve .....	19
Motor Brush Replacement .....	10	Parts Drawing – Sprayer .....	20
Displacement Pump Repair .....	12	Parts List – Sprayer .....	21
Motor Replacement .....	13	Technical Data .....	27
Motor Start Board .....	14	Dimensions .....	27
Power Supply Cord .....	14	Graco Warranty .....	28
On/Off Switch .....	14		

GRACO INC. P.O. BOX 1441 MINNEAPOLIS, MN 55440-1441

©COPYRIGHT 1998, GRACO INC.

Graco Inc. is registered to I.S. EN ISO 9001

# Component Identification and Function

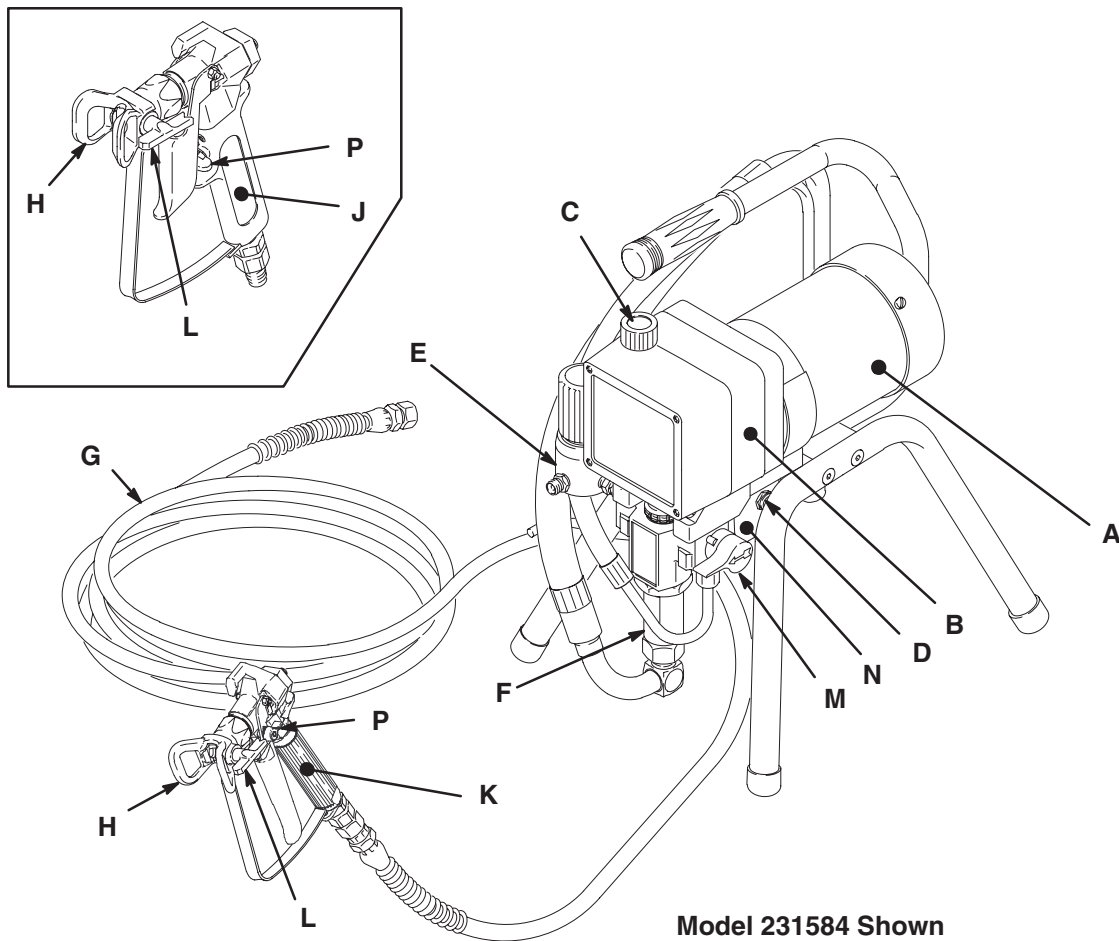

Model 231584 Shown

06973

Fig. 1

<b>A</b>	Motor	DC motor, 120 Vac, 15A, 1 phase
<b>B</b>	Drive Assembly	Transfers power from DC motor to the displacement pump
<b>C</b>	Pressure Adjusting Knob	Controls fluid outlet pressure
<b>D</b>	ON/OFF Switch	Power switch that controls 120 Vac power to sprayer
<b>E</b>	Fluid Outlet	Hose and spray gun is connected here
<b>F</b>	Displacement Pump	Pressurizes fluid to be sprayed through spray gun
<b>G</b>	50 ft (15 m) Main Hose	1/4 in. ID, grounded, nylon hose with spring guards on both ends
<b>H</b>	RAC IV Tip Guard	Reverse-A-Clean (RAC) tip guard reduces the risk of fluid injection injury
<b>J</b>	Contractor ST Gun	High pressure spray gun with gun safety latch
<b>K</b>	Contractor FTx Gun	High pressure spray gun with gun safety latch
<b>L</b>	RAC IV Switch Tip	RAC switch tip atomizes fluid and removes clogs from spray tip without removing tip from spray gun
<b>M</b>	Pressure Drain Valve	Relieves fluid pressure when open
<b>N</b>	Pressure Control	Controls motor to maintain fluid pressure. Works with pressure adjusting knob.
<b>P</b>	Spray Gun Safety Latch	Inhibits accidental triggering of spray gun

# General Repair Information

## CAUTION

To reduce risk of pressure control malfunction:

- Use needle nose pliers to disconnect a wire. Never pull on wire, pull on connector.
- Mate wire connectors properly. Center flat blade of insulated male connector in female connector.
- Route wires carefully to avoid interference with other connections of pressure control. Do not pinch wires between cover and control box.

### Tool List

Phillips screwdriver	1/4 in. hex key wrench
Small flat blade screwdriver	3/16 in. hex key wrench
Needle nose pliers	5/8 in. socket wrench
Plastic mallet or 20 oz (max) hammer	3/8 in. open end wrench
12 in. adjustable wrench	1/2 in. open end wrench
Adjustable, open-end wrench	3/4 in. open end wrench
Torque wrench	7/8 in. open end wrench
	High quality motor oil
	Bearing grease

1. **Keep all screws, nuts, washers, gaskets, and electrical fittings** removed during repair procedures. These parts are not normally provided with replacement assemblies.

## WARNING



### ELECTRIC SHOCK HAZARD

To reduce risk of serious injury, including electric shock, do not touch moving or electrical parts with fingers or tools while testing repair. Shut off and unplug sprayer when inspection is complete. Install all covers, gaskets, screws and washers before operating sprayer.

2. **Test repair** after problem is corrected.
3. **If sprayer does not operate properly**, review repair procedure to verify procedure was done correctly. If necessary, see Troubleshooting Guide, pages 5 – NO TAG, for other possible solutions.

## WARNING



### EXPLOSION HAZARD

Motor and drive housing are very hot during operation and could burn skin if touched. Flammable materials spilled on hot, bare motor could cause fire or explosion. Have motor shield in place during operation to reduce risk of burns, fire or explosion.

## CAUTION

Do not run sprayer dry for more than 30 seconds to avoid damaging pump packings.

4. **Install motor shield before operation** of sprayer and replace if damaged. Motor shield directs cooling air around motor to prevent overheating. It can also reduce risk of burns, fire or explosion; see preceding **WARNING**.

### Pressure Relief Procedure

## WARNING



### INJECTION HAZARD

System pressure must be manually relieved to prevent system from starting or spraying accidentally. Fluid under high pressure can be injected through skin and cause serious injury. To reduce risk of injury from injection, splashing fluid, or moving parts, follow **Pressure Relief Procedure** whenever you:

- are instructed to relieve pressure,
- stop spraying,
- check or service any system equipment,
- or install or clean spray tip.

1. Lock gun safety latch.
2. Turn ON/OFF switch to OFF.
3. Unplug power supply cord.
4. Unlock gun safety latch. Hold metal part of gun firmly to grounded metal pail. Trigger gun to relieve pressure.
5. Lock gun safety latch.
6. Open pressure drain valve. Leave pressure drain valve open until ready to spray again.

*If suspected that spray tip or hose is completely clogged, or that pressure has not been fully relieved after following steps above, VERY SLOWLY loosen tip guard retaining nut or hose end coupling to relieve pressure gradually, then loosen completely. Now clear tip or hose obstruction.*

# Grounding

## **⚠ WARNING**

Improper installation or alteration of grounding plug results in risk of electric shock, fire or explosion that could cause serious injury or death.

1. Models 231584, 231818, 231585, 232676, 232677 and 231819 require a 120 VAC, 50/60 Hz, 15A circuit with a grounding receptacle. See Fig. 2.
2. Do not alter ground prong or use adapter.

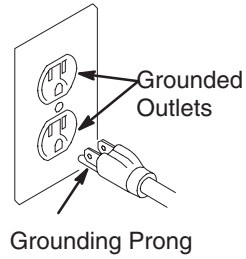

**Fig. 3**

3. A 12 AWG, 3 wires with grounding prong, 300 ft (90 m) extension cord may be used. Long lengths reduce sprayer performance.

# Troubleshooting



Relieve pressure; page 3.

## Basic Problem Solving

Check everything in the troubleshooting table before disassembling the sprayer.

TYPE OF PROBLEM	WHAT TO CHECK <i>If check is OK, go to next check</i>	WHAT TO DO <i>When check is not OK, refer to this column</i>
Fluid pressure	1. Pressure control knob setting. The pump won't develop much pressure if it is at minimum setting (fully counterclockwise).	1. Slowly increase pressure setting to see if motor starts.
	2. For clogged spray tip or fluid filter, if used. See manual 308645 or 308664.	2. If tip is still clogged, relieve pressure; refer to separate gun or tip instruction manual for tip cleaning. Clean or replace filter element. See manual 308249.
Mechanical	1. For frozen or hardened paint in pump (20). Using a screwdriver, carefully try to rotate fan at back of motor by hand. See page 9.	1. Thaw sprayer if water or water-based paint has frozen in sprayer. Place sprayer in warm area to thaw. Do not start sprayer until thawed completely. If paint hardened (dried) in sprayer, replace pump packings. See page 12 ( <b>Displacement Pump Repair</b> ).
	2. Displacement pump connecting rod pin (17). Pin must be completely pushed into connecting rod (15), and retaining spring (18) must be firmly in connecting rod groove. See Fig. 10, page 12.	2. Push pin into place and secure with spring retainer.
	3. For motor damage. Remove drive housing assembly (11). See page 15. Try to rotate motor fan by hand.	3. Replace motor (4) if fan won't turn. See page 13.
Electrical	1. Electrical supply. Meter must read: 100–120 VAC for models 231584, 231818, 231585, 232676, 232677 and 231819.	1. Reset building circuit breaker; replace building fuse. Try another outlet.
	2. Extension cord for visible damage. Use a volt meter or test lamp at extension cord outlet to check.	2. Replace extension cord.
	3. Sprayer power supply cord (50) for visible damage such as broken insulation or wires.	3. Replace power supply cord. See page 14.
	4. Check motor brushes for the following: a. Loose terminal screws. b. Broken or misaligned brush springs.  c. Brushes binding in holders.  d. Broken leads. e. Worn brushes. <b>NOTE:</b> The brushes do not wear at same rate on both sides of motor. Check both brushes.	4. Refer to page 10. a. Tighten. b. Replace broken spring and/or align spring with brush c. Clean brush holders. Remove carbon with small cleaning brush. Align brush leads with slot in brush holder to assure free vertical brush movement. d. Replace brushes e. Replace brushes if less than 0.5 in. long.

# Basic Problem Solving

TYPE OF PROBLEM	WHAT TO CHECK <i>If check is OK, go to next check</i>	WHAT TO DO <i>When check is not OK, refer to this column</i>
Electrical <i>(continued)</i>	5. Motor armature commutator for burn spots, gouges and extreme roughness. Remove motor cover and brush inspection plates to check. See page 10.	5. Remove motor and have motor shop resurface commutator if possible. See page 13.
	6. Motor armature for shorts using armature tester (growler) or perform motor test. See page 9.	6. Replace motor. See page 13.
	7. Leads from pressure control and motor to motor start board (47) to be sure they are securely fastened and properly mated.	7. Replace loose terminals; crimp to leads. Be sure male terminal blades are straight and firmly connected to mating part.
	8. Motor start board (47) by substituting with a good board. See page 14.  <b>CAUTION:</b> Do not perform this check until motor armature is determined to be good. A bad motor armature can burn out a good board.	8. Replace board. See page 14.
	9. Power supply cord (50). Disconnect black and white power cord terminals; connect volt meter to these leads. Plug in sprayer. Meter must read: 100–120 VAC for models 231584, 231818, 231585, 232676, 232677 and 231819. Unplug sprayer.	9. Replace power supply cord. See page 14.
	10. ON/OFF switch (52). Disconnect the motor start board (47) and switch and connect volt meter between exposed terminal on switch and power cord's white wire. Plug in sprayer and turn <b>ON</b> . Meter must read: 100–120 VAC for models 231584, 231818, 231585, 232676, 232677 and 231819.	10. Replace ON/OFF switch. See page 14.
	11. Motor thermal cutout switch. Connect ohmmeter between motor's red leads. Meter should read 1 ohm maximum.	11. Allow motor to cool. Correct cause of overheating. If switch remains open after motor cools, replace motor.
	12. Remove pressure control (64) and check microswitch operation with ohmmeter:  (1) With pressure knob at lowest setting and stem pushed into control, readings should be: white & black = 1 ohm max. white & red = open.  (2) With pressure knob at highest setting, readings should be: white & black = open; white & red = 1 ohm max.	12. Replace pressure control. See page 17.
	13. Pressure transducer (29) for hardened paint or damaged or worn components. See page 18.	13. Replace transducer. See page 18. Thorough system flushing will help extend life of transducer.

# Intermediate Problem Solving

TYPE OF PROBLEM	WHAT TO CHECK <i>If check is OK, go to next check</i>	WHAT TO DO <i>When check is not OK refer to this column</i>
Low output	1. For worn spray tip.	1. Follow <b>Pressure Relief Procedure</b> then replace tip. See your separate gun or tip manual.
	2. Be sure pump does not continue to stroke when gun trigger is released. Plug in and turn on sprayer. Prime with paint. Trigger gun momentarily, then release and lock safety latch. Relieve pressure, turn off and unplug sprayer.	2. Service pump. See page 12.

# Intermediate Problem Solving

TYPE OF PROBLEM	WHAT TO CHECK <i>If check is OK, go to next check</i>	WHAT TO DO <i>When check is not OK, refer to this column</i>
Low output ( <i>continued</i> )	3. Release gun trigger. Observe resting position of pump rod (107).	3. If pump consistently comes to rest with rod (107) fully extended, the piston packings and/or piston valve may be worn. Service the pump. See page 12.
	4. Electrical supply. Meter must read: 100–120 VAC for models 231584, 231818, 231585, 232676, 232677 and 231819.	4. Reset building circuit breaker; replace building fuse. Repair electrical outlet or try another outlet.
	5. Extension cord size and length; must be at least 12 gauge wire and less than 150 ft (45 m) long.	5. Replace with a correct, grounded extension cord.
	6. Motor brushes. See Electrical – What To Check, item 4, on page 5.	6. See page 10.
	7. Motor start board (47) by substituting with a good board.  <b>CAUTION:</b> Do not perform this check until motor armature is determined to be good. A bad motor armature can burn out a good board.	7. Replace board. See page 14.
	8. Motor armature for shorts by using an armature tester (growler) or perform motor test. See page 9.	8. Replace motor. See page 13.
Drain valve leaks	1. Drain valve for correct torque and/or worn parts. Check for debris trapped on seat.	9. Tighten to 185 in–lb (21 N.m). Clean valve and replace with new gasket (42a) and sealant (42d). See page 19.
Transducer leaks	1. Slight leakage from transducer is normal.	1. Periodically remove residue from its cylinder port. See page 18.
No output: motor runs and pump strokes	1. Paint supply.	1. Refill and reprime pump.
	2. For clogged intake strainer.	2. Remove and clean, then reinstall.
	3. For loose suction tube or fittings. See page 18.	3. Tighten; use thread sealant on npt threads of adapter (38).
	4. To see if intake valve ball and piston ball are seating properly. See page 12.	4. Remove intake valve and clean. Check ball and seat for nicks; replace as needed. See page 12. Strain paint before using to remove particles that could clog pump.
	5. For leaking around throat packing nut which may indicate worn or damaged packings. See page 12.	5. Replace packings. See page 12. Also check piston valve seat for hardened paint or nicks and replace if necessary. Tighten packing nut/wet-cup.
	6. Release gun trigger. Observe resting position of pump rod (107).	6. If pump consistently comes to rest with rod (107) fully extended, the piston packings and/or piston valve may be worn. Service the pump. See page 12.
No output: motor runs but pump does not stroke	1. Displacement pump connecting rod pin (17). See Fig. 10, page 12.	1. Replace pin if missing. Be sure retainer spring (18) is fully in groove all around connecting rod.
	7. Connecting rod assembly (15) for damage. See page 15.	7. Replace connecting rod assembly. See page 15.
	8. Be sure crank in drive housing rotates; plug in sprayer and turn on briefly to check. Turn off and unplug sprayer. See page 15.	8. Check drive housing assembly for damage and replace if necessary. See page 15.

# Intermediate Problem Solving

TYPE OF PROBLEM	WHAT TO CHECK <i>If check is OK, go to next check</i>	WHAT TO DO <i>When check is not OK, refer to this column</i>
Spray Pattern Variations	1. Spray tip worn beyond sprayer pressure capability.	1. Replace spray tip. <b>NOTE:</b> A smaller size tip will provide longer life.
	2. Transducer (29) for wear or damage.	2. Replace transducer. See page 18.
	3. Pressure control (64) for smooth operation.	3. Replace pressure control. See page 17.
	4. Low output section, page 7.	
Motor Is Hot and Runs Intermittently	1. Determine if sprayer was operated at high pressure with small tips, which causes excessive heat build up.	1. Decrease pressure setting or increase tip size.
	2. Be sure ambient temperature where sprayer is located is no more than 90° F (32° C) and sprayer is not located in direct sun.	2. Move sprayer to shaded, cooler area if possible.
	3. Motor.	3. Replace motor. See page 13.
Building Circuit Breaker Opens As Soon As Sprayer Switch Is Turned On.	1. All electrical wiring for damaged insulation, and all terminals for loose fit or damage. Also check wires between pressure control and motor. See page 13.	1. Repair or replace any damaged wiring or terminals. Securely reconnect all wires.
	2. For missing motor brush inspection plate gasket (see page 9), bent terminal forks or other metal to metal contact points which could cause a short.	2. Correct faulty conditions.
	3. Motor armature for shorts. Use an armature tester (growler) or perform motor test. See page 9. Inspect windings for burns.	3. Replace motor. See page 13.
	4. Motor start board (47) by substituting with a good board.  <b>CAUTION:</b> Do not perform this check until motor armature is determined to be good. A bad motor armature can burn out a good board.	4. Replace board. See page 14.
Circuit breaker opens after sprayer operates for 5 to 10 minutes.	1. Basic Problems – Electrical on page 5.	
Building circuit breaker opens as soon as sprayer is plugged into outlet and sprayer is NOT turned on.	1. ON/OFF switch (52). <i>Be sure sprayer is unplugged!</i> Disconnect wires from switch. Check switch with ohmmeter. The reading should be infinity with ON/OFF switch OFF, and zero with switch ON.  <b>CAUTION:</b> A short in motor circuit can damage switch and or motor start board (47).	1. Replace ON/OFF switch. See page 14.
	2. Electrical supply. Meter must read: 100–120 VAC for models 231584, 231818, 231585, 232676, 232677 and 231819.	2. If voltage is too high, do not operate sprayer until corrected.
Unit will not run on generator but does run on AC power	Generator peak voltage. Models 231584, 231818, 231585, 232676, 232677 and 231819 will not run if the peak voltage is above 190V.	Use AC power or a different generator



# Motor Test



Relieve pressure; page 3.

For checking armature, motor winding and brush electrical continuity.

## Setup

Remove the drive housing. See page 15. This is to ensure that any resistance you notice in the armature test is due to the motor and not to worn gears in the drive housing.

Remove the motor brush inspection covers (A). See Fig. 4.

Remove the junction box screws (56). Lower the junction box. Disconnect the two leads (C) from the motor to the board (47). See Fig. 5.

## Armature Short Circuit Test

Remove the fan cover (B). See Fig. 4.

Spin the motor fan by hand. If there are no shorts, the motor will coast two or three revolutions before coming to a complete stop. If the motor does not spin freely, the armature is shorted and the motor must be replaced. See page 13.

## Armature, Brushes, and Motor Wiring Open Circuit Test (Continuity)

Connect the two black motor leads together with a test lead. Turn the motor fan by hand at about two revolutions per second.

When turning the fan on a DC motor, normally you sense an even, pulsing resistance. If there is irregular turning resistance, or no turning resistance, check and repair the following as needed: broken brush springs, brush leads, motor leads; loose brush terminal screws or motor lead terminals; worn brushes. See page 10.

If there is still uneven or no turning resistance, replace the motor. See page 13.

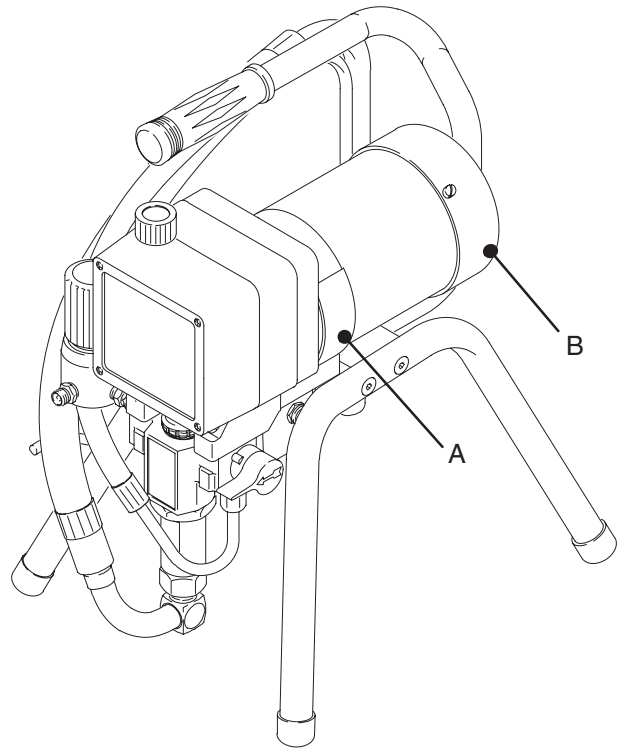

Fig. 4 Model 231584 Shown

06975

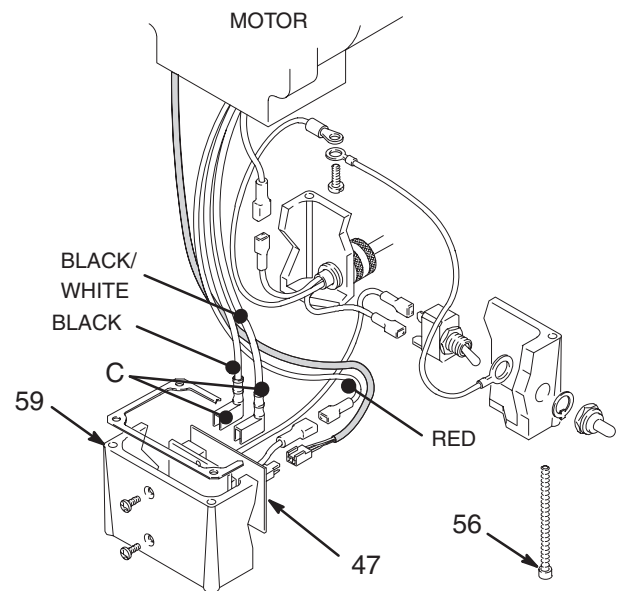

Fig. 5

04720

# Motor Brush Replacement

**NOTE:** Replace brushes when worn to about 0.5 in. (12.5 mm). Always check both brushes. Brush Repair Kit 236-967, which includes spring clip 112-766, is available for motors manufactured by Pacific Scientific.

**NOTE:** Replacement brushes may last only half as long as the original ones. To maximize brush life, break in new brushes by operating the sprayer for at least one hour with no load (remove the pump connecting rod pin).



Relieve pressure; page 3.

1. Remove both inspection covers (A) and their gaskets. See Fig 6.

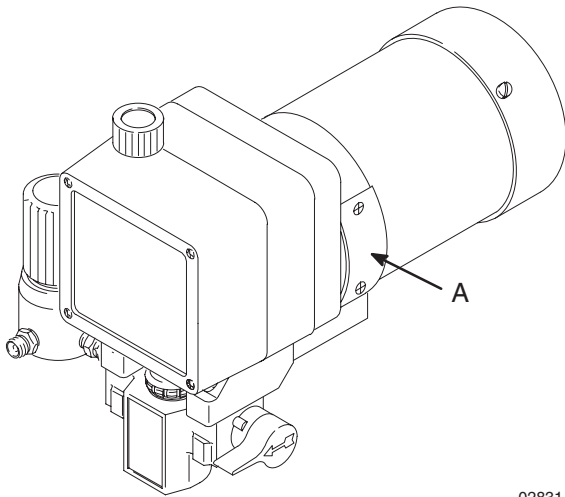

02831A

Fig. 6

2. Push in the spring clip (F) and release its hook (G) from the brush holder (B). Pull out the spring clip. See Fig 7.
3. Slide off the brush lead terminal (E) off the blade connector. Remove the old brush (C). See Fig 7.

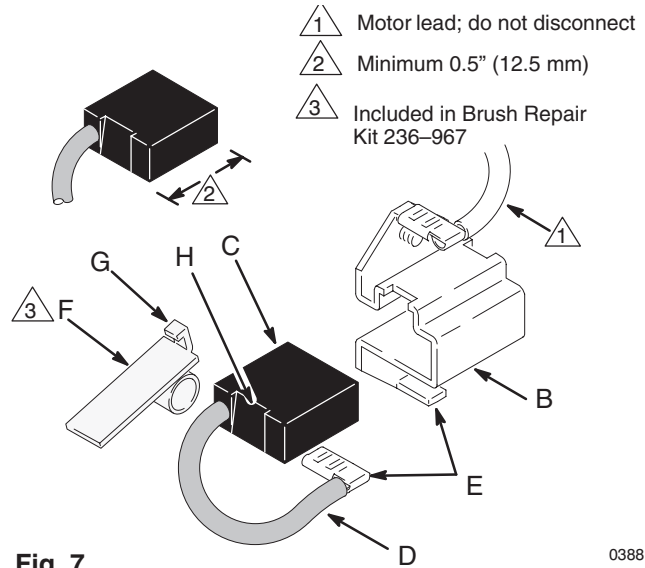

Fig. 7

03881

4. Inspect the commutator for excessive pitting, burning or gouging. A black color on the commutator is normal. Have the commutator resurfaced by a qualified motor repair shop if the brushes seem to wear too fast or arc excessively. See Step 9.d., also.
5. Repeat for the other side.

**NOTE:** The motor brushes on the other side are upside down.

6. Place a new brush (C) in the holder (B) so the ramp (H) faces the spring. See Fig. 16.

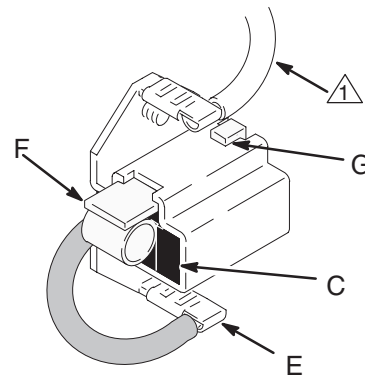

Fig. 8

03881

7. Holding the spring clip (F) at a slight angle, slide the spring clip into the brush holder and hook it over the end of the holder. See Fig. 8. Pull on the spring clip to be sure it stays in place. Connect the brush lead to the blade connector (E).
8. Repeat for the other side.

# Motor Brush Replacement

## 9. Test the brushes.

- a. Remove the pump connecting rod pin (17). See Fig. 10, page 12.
- b. With the sprayer OFF, turn the pressure control knob fully counterclockwise to minimum pressure. Plug in the sprayer.
- c. Turn the sprayer ON. Slowly increase the pressure until the motor is at full speed.
- d. Inspect the brush and commutator contact area for excessive arcing. Arcs should not trail or circle around the commutator surface.

## WARNING



### MOVING PARTS HAZARD

Do not touch the brushes, leads, springs or brush holders while the sprayer is plugged in to reduce the risk of electric shock and serious injury.

10. Install the brush inspection covers and gaskets.
11. **Break in the brushes.** Operate the sprayer for at least one hour with no load. Install the pump connecting rod pin. See Fig. 10, page 12.

# Displacement Pump Repair



Relieve pressure; page 3.

**NOTE:** Packing Repair Kit 235703 is available. Reference numbers of parts included in the kit are marked with an asterisk, i.e., (121\*). For the best results, use all the new parts in the kit, even if the old ones still look good.

**NOTE:** To minimize down time, and for the best sprayer performance, check the motor brushes (see page 10) and clean the transducer (see page 18) whenever you repack the pump. Replace these parts as needed.

## Removing the pump (See Fig. 9.)

1. Flush the pump, if possible. Relieve pressure. Stop the pump with the piston rod (107) in its lowest position, if possible. To lower the piston rod manually, rotate the motor fan blades.
2. Remove the filter (85).
3. Remove suction hose or tube (32). (For suction hose, refer to page 18.)
4. Use a screwdriver to push the retaining spring (18) up and push out the pin (17).
5. Loosen the screws (21). Remove the pump (20).

## Repairing the pump

See manual 308190 for pump repair instructions.

## Installing the pump (See Fig. 9 and 10.)

1. Mount the pump on the drive housing. Tap it into the alignment pins with a soft hammer. Tighten the screws (21) to 50 ft-lb (68 N.m).

2. Align the hole in the rod (107) with the connecting rod assembly (15). Use a screwdriver to push the retaining spring (18) up and push in the pin (17). Push the retaining spring (18) into place around the connecting rod.
3. Replace the o-ring (27) if it is worn or damaged. Reconnect the suction and drain hoses (32,33). Install the front cover (13).
4. Tighten the packing nut (102) just enough to stop leakage, but no tighter. Fill the packing nut/wet-cup 1/3 full with Graco TSL. Push the plug (123) into the wet-cup.

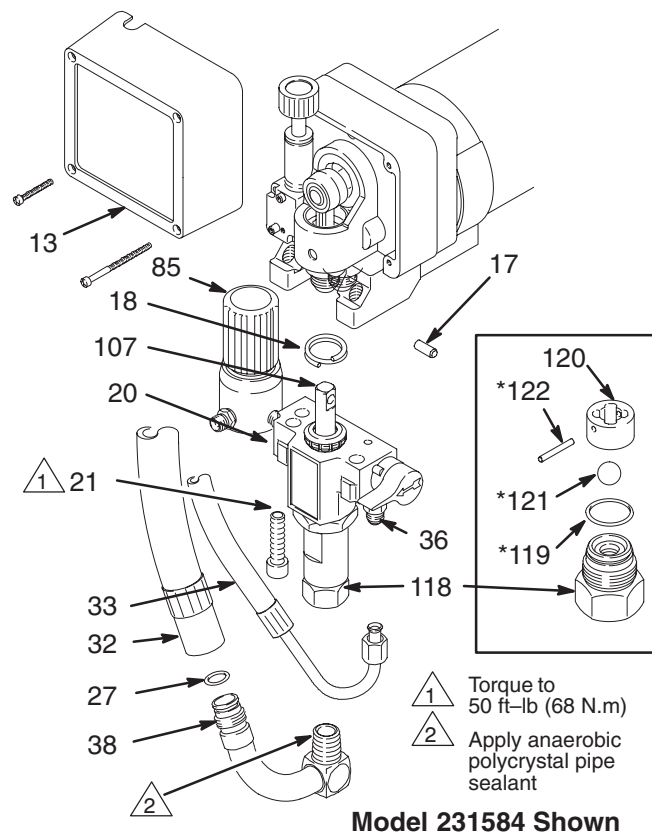

Fig. 9

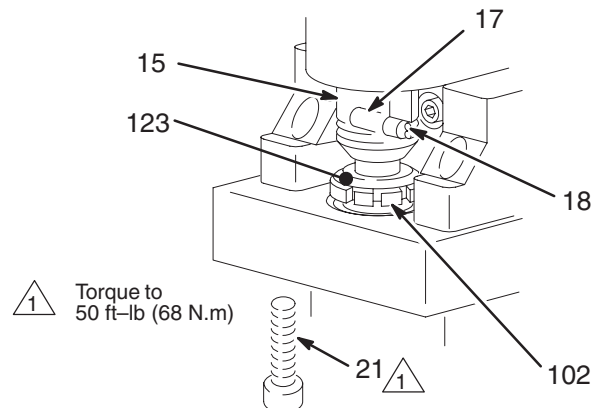

Fig. 10

04655

## WARNING



### MOVING PARTS HAZARD

Be sure the retaining spring (18) is firmly in the groove all the way around, to prevent the pin (17) from working loose due to vibration. See Fig. 10.

If the pin works loose, it or other parts could break off due to the force of the pump action. These parts could be projected into the air and result in serious injury or property damage, including the pump connecting rod or drive housing.

# Motor Replacement



Relieve pressure; page 3.

**NOTE:** See Fig. 13 except where noted.

1. Relieve pressure.
2. Try to stop the pump with the piston rod (107) in its lowest position. To lower the piston rod manually, rotate the motor fan blades. Use a screwdriver to push the retaining spring (18) up and push out the pin (17). See Fig. 11.
3. Remove the screws (56) and lower the junction box (59). Disconnect the motor wires and the pressure control wire (A) from the motor start board. Refer to Fig. 14 on page 14.
4. Remove the front cover (13).
5. Turn the displacement pump rod (107) so the pin hole aligns with the bottom drive housing screw (19). See Fig. 12. Remove the three drive housing screws and lockwashers (19,6). Also see Fig. 13.
6. Remove the two motor screws (5) and the lock washers (6).
7. Tap the lower rear of the drive housing (11) with a plastic mallet to loosen the motor. Pull the drive housing straight off the motor while guiding the harness (A) from the motor. Do not allow the gear (16) to fall. Read the CAUTION on page 15.
8. Remove the two screws (46) and lift the motor off the base (66).
9. Align the new motor with the base and reinstall the screws (46).

10. Assemble the drive housing to the motor. Follow steps 8 to 10 on page 15.

11. Connect the wires in the junction box. Refer to Fig. 14 on page 14. Install the junction box.

12. Connect the piston rod (107) to the drive housing; see page 12, **Installing the Pump**, Step 2 and the **WARNING** following it.

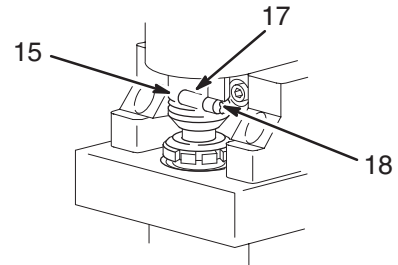

Fig. 11

01068

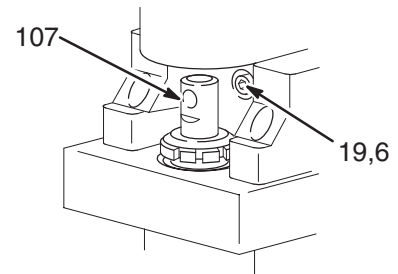

Fig. 12

01074

- Torque to 2.4 N.m (21 in-lb)
- Quantity of three
- Quantity of one

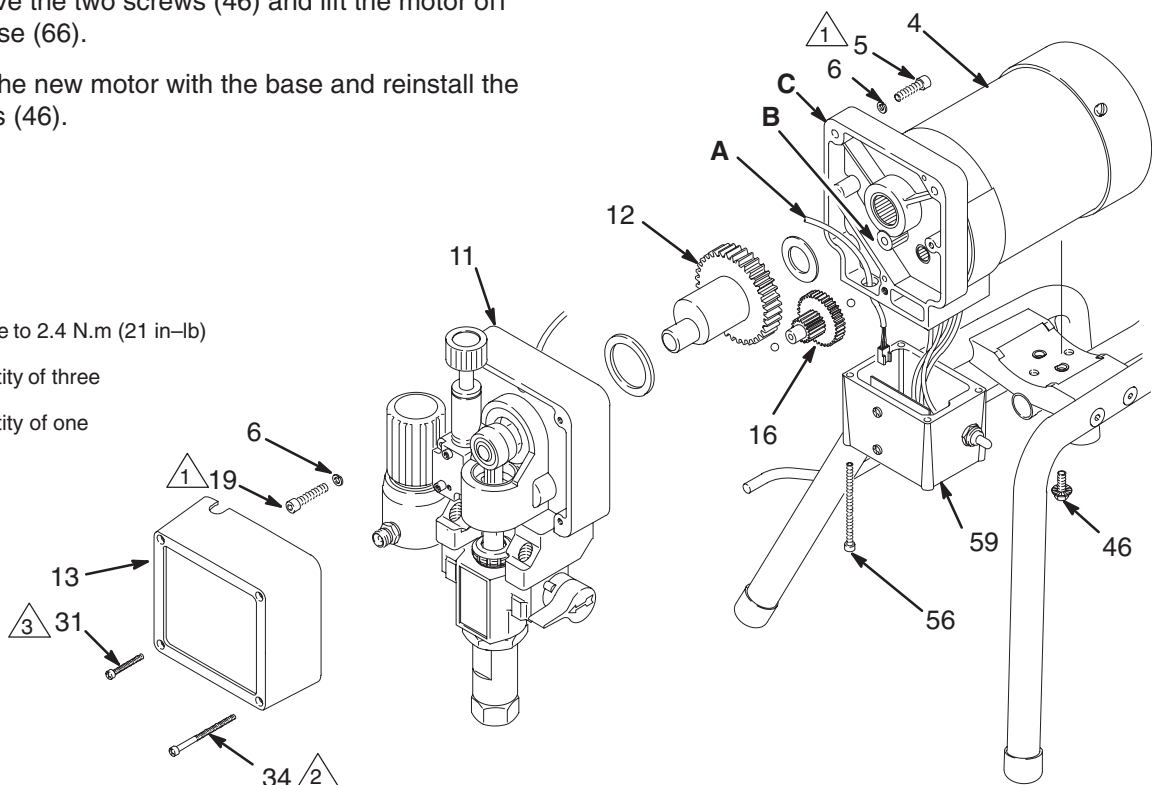

Fig. 13

05119

# Motor Start Board



Relieve pressure; page 3.

**NOTE:** See Fig. 14 for this procedure.

1. Relieve pressure.
2. Remove the junction box screws (56) and lower the junction box (59).
3. Disconnect the motor wires (B) and the 3-wire connector (A) from the motor start board (47). Observe where connections are made.
4. Remove the screws (58) and motor start board (47). Transfer the white thermal paste from the old board to the new board.
5. Install the new motor start board. Reconnect all wires. Install the junction box. Be sure no leads are pinched against the motor or by the motor start board. Also be sure the gasket (89) is installed.

## ⚠ CAUTION

Be sure the flat blade of the insulated male connector is centered in the wrap-around blade of the female connector when the connections are made.

Route all wires carefully to avoid interference with the motor start board or junction box.

These precautions are essential to reduce the risk of a malfunction.

# Power Supply Cord

**NOTE:** See Fig. 14 for this procedure.

1. Relieve pressure.
2. Remove the junction box screws (56) and lower the junction box (59).
3. Disconnect the power supply cord leads, including the green wire to the grounding screw (49).
4. Loosen the strain relief bushing (51). Remove the power supply cord (50).
5. Install the new cord (50) in the reverse order of disassembly.

6. Install the junction box. Be sure no leads are pinched against the motor or by the motor start board. Also be sure the gasket (89) is installed.

# On/Off Switch

**NOTE:** See Fig. 14 for this procedure.

1. Relieve pressure.
2. Remove the junction box screws (56) and lower the junction box (59).
3. Remove the nut and rubber boot (55).
4. Disconnect the black wires from the ON/OFF switch (52) and remove the switch.
5. Place the ring terminal of the ground wire (53) over the barrel of the new switch. Install the switch so the internal tab of the anti-rotation ring (54) engages with the vertical groove in the threads of the switch, and the external tab engages with the blind hole (C) of the junction box.
6. Powder the inside of the rubber boot (55) with talcum, then shake the excess out of the boot. Install the nut and rubber boot and tighten.
7. Reconnect the ON/OFF switch black wires.
8. Install the junction box. Be sure no leads are pinched against the motor or by the motor start board. Also be sure the gasket (89) is installed.

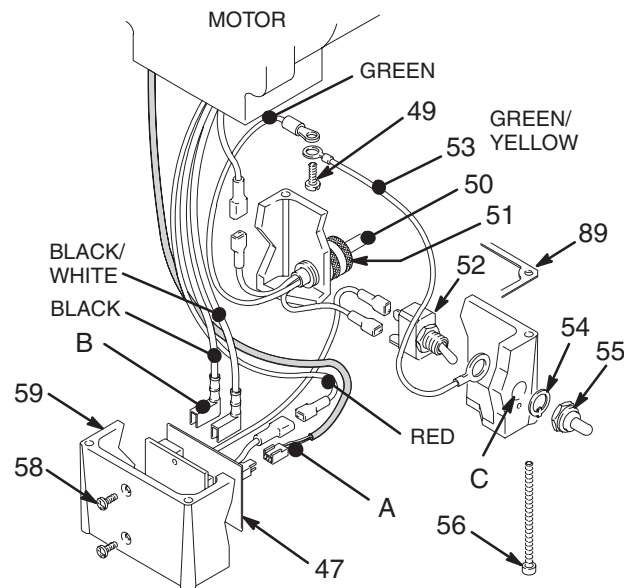

Fig. 14

04720

# Drive Housing, Connecting Rod, Crankshaft



Relieve pressure; page 3.

## Removal

**NOTE:** Inspect parts as they are removed. Replace parts that are worn or damaged.

1. Remove the displacement pump. See page 12.
2. Remove the pressure control (64). See page 17.
3. Turn the displacement pump rod (107) so the pin hole aligns with the bottom drive housing screw (19). See Fig. 15. Remove the three drive housing screws and lockwashers (19,6). Also see Fig. 16 on page 16.

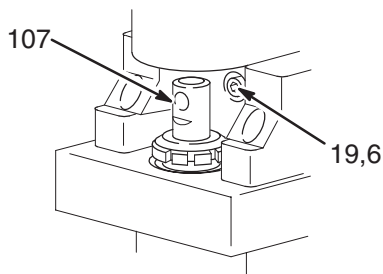

Fig. 15

01074

4. Remove the two motor screws (5) and lock washers (6). See Fig. 16 on page 16.
5. Tap the lower rear of the drive housing (11) with a plastic mallet to loosen the motor. Pull the drive housing straight off the motor.

## CAUTION

Do not allow the gear (16) to fall; it may stay attached to the drive housing or to the motor.

Do not lose the thrust balls (11a or 4a) or let them fall between the gears, which will damage the drive housing if not removed. The balls, which are heavily covered with grease, usually stay in the gear recesses, but could be dislodged. If the balls are not in place, the bearings will wear prematurely.

6. Remove and inspect the crankshaft (12) and the connecting rod (15).

## Installation

7. Install the connecting rod.
  8. Lubricate the inside of the drive housing bearing with SAE non-detergent oil. Pack the roller bearing and gears with the grease supplied.
- NOTE:** The gears and bearings between the drive housing (11) and motor front end bell (C) should contain a total of 3 fl. oz. (29 cc) of grease.
9. Place the large washer (12a) and then the small washer (12b) on the crankshaft (12).
  10. Lift the crank to the top of the stroke and insert crankshaft (12). Align the gears and push the drive housing (11) straight onto the motor and the locating pins. Install the screws (19, 5) and their lockwashers (6). Torque to 80 in-lb (9 N.m).
  11. Install the displacement pump. See page 12.
  12. Install the pressure control (64). See page 17. Install the front cover (13).

# Drive Housing, Connecting Rod, Crankshaft

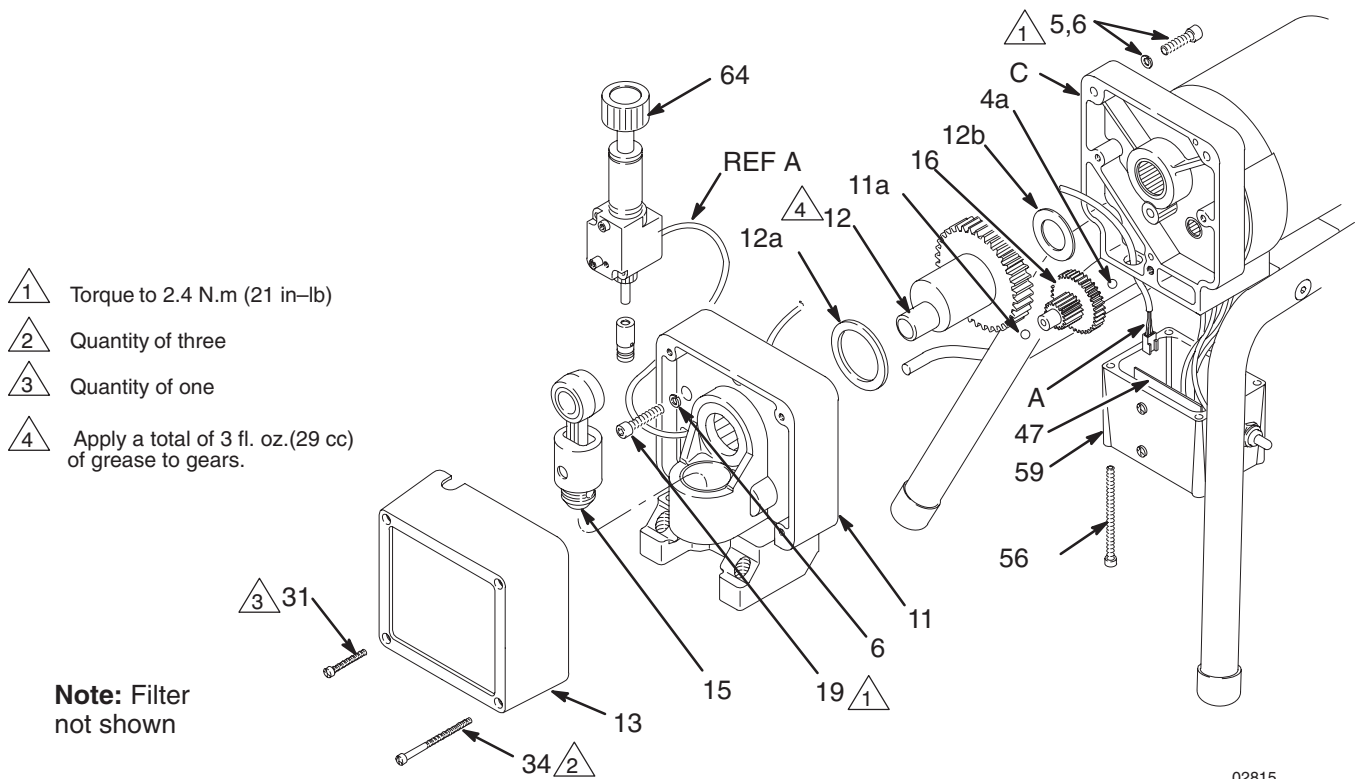

02815

Fig. 16



# Pressure Control



Relieve pressure; page 3.

**NOTE:** See Fig. 17 for this procedure.

**NOTE:** The pressure control (64) cannot be repaired or adjusted. If it has malfunctioned, replace it.

1. Remove the front cover (13). Remove the screws (56). Lower the junction box (59).
2. Disconnect the harness connector (A) from the motor start board (47).
3. Remove the screws (63). Pull forward on the pressure adjusting knob and tip the pressure control (64) forward and up to detach it from the drive housing (11).
4. Guide the harness (A) through the motor and drive housing and remove the pressure control.
5. Guide the harness of the new pressure control through the drive housing and motor passages.
6. Install the new pressure control. Tip the pressure control down and back into the drive housing (11). Do not pinch or damage the harness (A).
7. Loosely install the screws (63) and then torque them to 21 in-lb (2.4 N.m).

8. Install the front cover (13). Connect the harness (A) to the motor start board (47).
9. Install the junction box. Be sure no leads are pinched against the motor or by the motor start board.

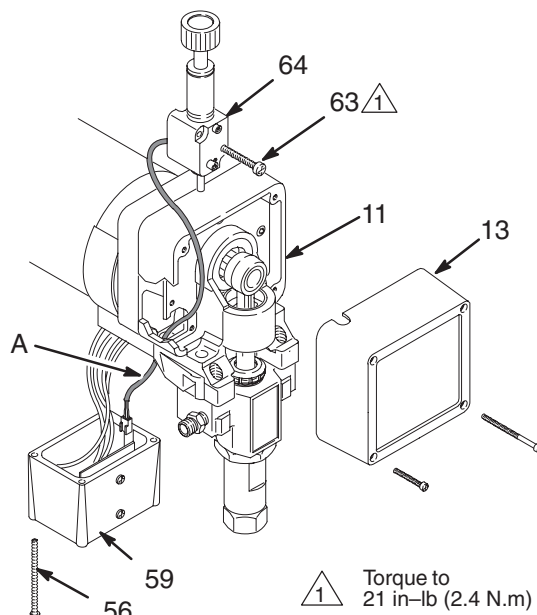

Fig. 17

02816A

# Pressure Transducer



Relieve pressure; page 3.

**NOTE:** See Fig. 18 for this procedure.

1. Remove the displacement pump. See page 12.
2. Use a pull-twist motion to remove the transducer (29) from the pump manifold (101).
3. Clean paint residue from the hole in the manifold; do not scratch the surface of the hole.
4. Lightly apply oil to the o-ring of the new transducer.
5. Install the transducer in the pump manifold, while guiding the o-ring and backup ring into place.
6. Align the holes in the transducer as shown by the arrows in Fig. 18.
7. Install the displacement pump. See page 12.

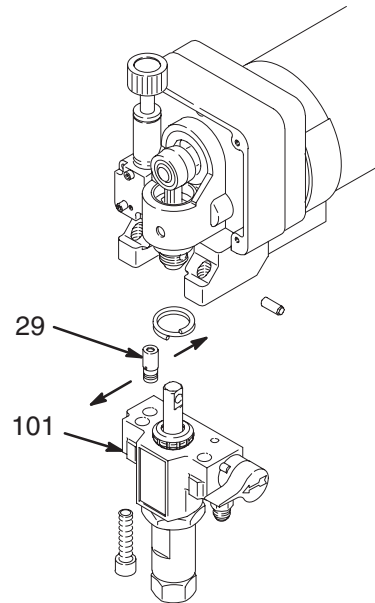

Fig. 18

02817A

# Suction Hose

## Models 231584 and 231585



Relieve pressure; page 3.

1. Remove the drain hose (33) from the clip. Remove the front cover (13).
2. Pull upward on the hose (32) while unscrewing it from the inlet tube (38). The hose coupling (A) threads will engage and the hose will separate from the tube.
3. Replace the o-ring (27) if it is worn or damaged.
4. Lubricate the o-ring (27) and the inlet tube (38) threads with light grease.
5. Align the suction hose coupling with the threads of the inlet tube (38). Tighten the hose onto the tube at least 4 turns to ensure that the threads have disengaged and can function as a swivel joint.

 Lubricate

**Note:** Filter not shown

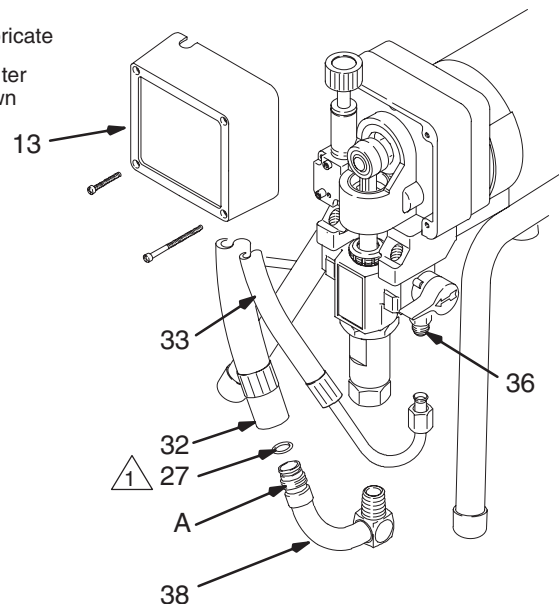

Fig. 19

Model 231584 Shown

06978

## CAUTION

Misalignment or cross-threading will damage the parts and/or create shavings which can cause the o-ring (27) to leak.

# Drain Valve



Relieve pressure; page 3.

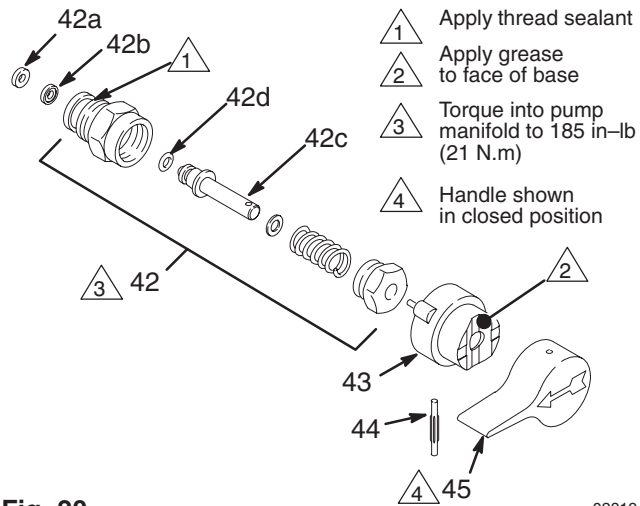

Fig. 20

02819

1. Turn the handle (45) to the closed position. Drive out the pin (44). Remove the handle.
2. Remove the base (43).
3. Unscrew the drain valve (42). The gasket (42a) and seat (42b) will stay in the valve.

## Repair

1. Unscrew the spring retainer from the valve body. Remove the spring, washers and stem/ball. Clean any debris from the ball or seat area.
2. If replacing the gasket (42a) or seat (42b), pry out the gasket.

**NOTE:** Whenever the gasket (42a) is removed, replace it with a new one.

3. Coat the o-ring (42d) with grease. Press the stem into the valve body. Install the spring, washers and spring retainer into the valve body.
4. Place the seat (42b) in the valve body so the lapped side is toward the ball. Apply a small amount of grease to the new gasket (42a) and install it in the valve body.

**NOTE:** The gasket will protrude from the end of the valve until the valve is tightened into pump, which correctly seats the gasket.

## Replacement

1. Apply a small amount of thread sealant (42e) onto the valve (42) threads. Tighten the valve into the pump manifold to 185 in-lb (21 N.m).
2. Lightly grease the face of the base (43) and install the base. Turn the stem so the pin hole is vertical.
3. Securely install the handle (45) and drive pin (44).

# Sprayer Parts Drawing

Model 231584, Series B  
 Model 231818, Series A

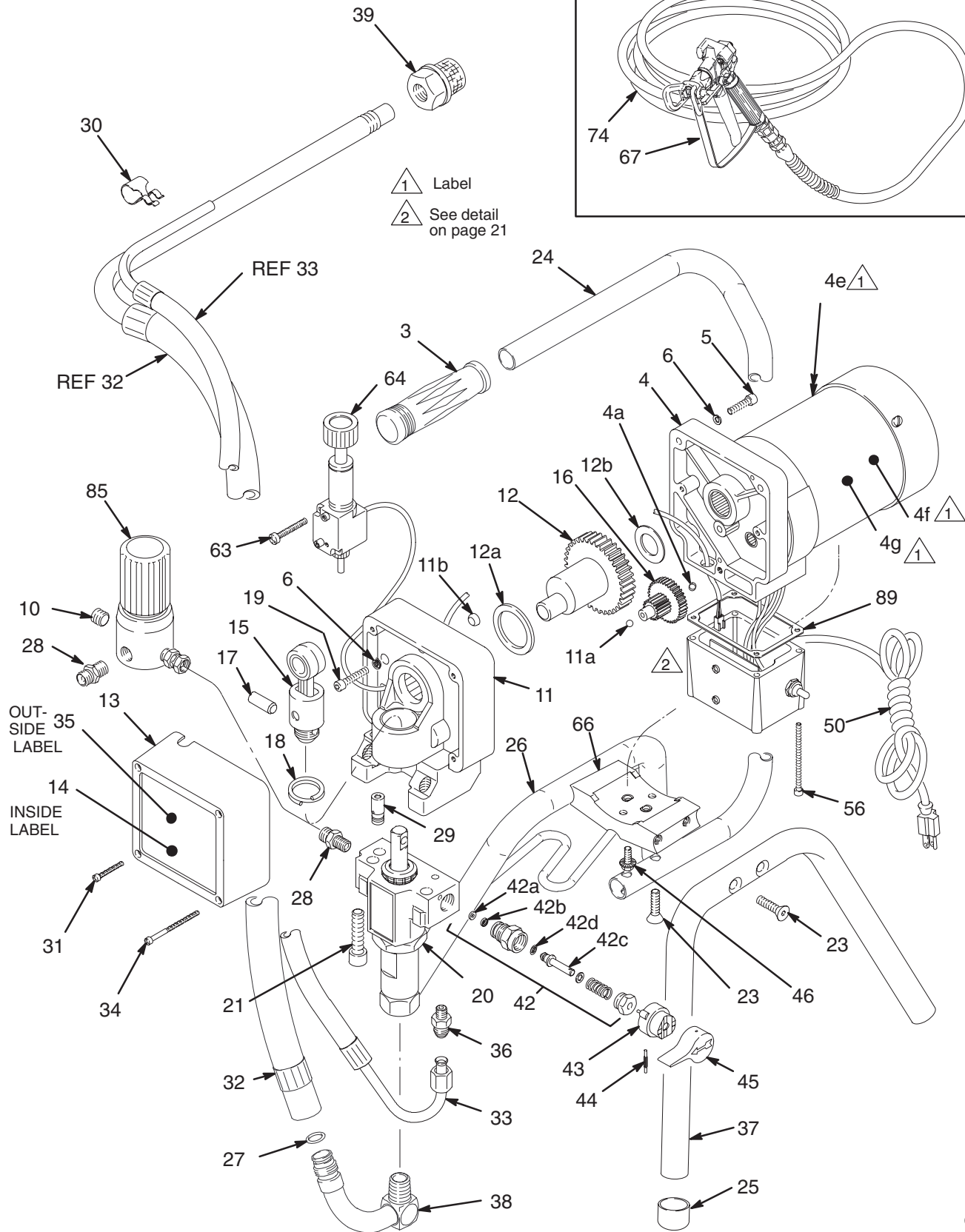
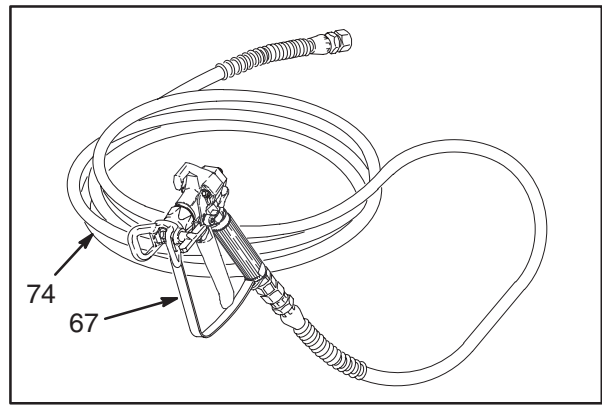

06974B

# Sprayer Parts List

Model 231584, Series B and Model 231818, Series A

Ref. No.	Part No.	Description	Qty.	Ref. No.	Part No.	Description	Qty.
3	111700	GRIP, handle	1	46	110997	SCREW, washer/hex hd, 5/16"	2
4†	237458	MOTOR KIT <i>Includes items 4a to 4f</i>	1	47	235707	MOTOR START BOARD <i>includes items 47a to 47c</i>	1
4a	100069	. BALL, sst, 1/4" dia.	1	48▲	186620	LABEL, ground terminal	1
4b	111616	. TERMINAL, flat, 1/4" (f), 18 awg	2	49	110037	SCREW, mach, pnhd, 10-24 x 5/8"	1
4c	107503	. TERMINAL, 3/16" (m), 16 awg	2	50	235010	POWER CORD SET	1
4d▲	187784	. LABEL, DANGER, French	1	51	111617	STRAIN RELIEF BUSHING, 3/8-18 npt	1
4e▲	187791	. LABEL, DANGER, English	1	52	105679	SWITCH, ON/OFF	1
4f▲	187975	. LABEL, WARNING, electric shock	1	53	235035	GROUND HARNESS	1
5	100643	SCREW, socket head, 1/4-20 x 1"	2	54	105658	LOCKING RING	1
6	105510	LOCKWASHER, 1/4"	5	55	105659	BOOT, switch	1
10	100721	PLUG, 1/4-18 npt(f)	1	56	111703	SCREW, filh, 10-24 x 3"	4
11	224965	DRIVE HOUSING KIT <i>Includes item 11a, 11b</i>	1	58	100035	SCREW, pan hd, 8-32 x 5/16"	2
11a	100069	. BALL, stainless steel, 1/4" dia.	1	59	187795	JUNCTION BOX	1
11b	111726	. PLUG	1	63	111704	SCREW, filh, 10-24 x 1-5/8"	2
12	224803	CRANKSHAFT <i>Includes items 12a, 12b</i>	1	64	239515	PRESSURE CONTROL KIT	1
12a	180131	. BEARING, thrust	1	66	189932	BASE, motor	1
12b	107434	. BEARING	1	67	238350	CONTRACTOR FTx GUN Used with Model 231584	1
13	187789	COVER, front	1			<i>See manual 308645 for parts</i>	
14▲	177762	LABEL, WARNING	1		238352	CONTRACTOR ST GUN Used with Model 231-818	1
15	218359	CONNECTING ROD	1			<i>See manual 308664 for parts</i>	
16	218364	GEAR REDUCER	1				
17	176818	PIN, headless, 3/8" dia. x 1"	1	68	206994	TSL, 8 oz. (not shown)	1
18	176817	SPRING, retaining	1	74	238361	HOSE, grounded, nylon; 1/4" ID; cpld 1/4 npsm(f); 50 ft (15 m); spring guards both ends	1
19	103345	SCREW, socket head, 1/4-20 x 1-1/4"	5				
20	235699	PUMP KIT <i>See manual 308190 for parts</i>	1	85	23747	FILTER, fluid <i>See Manual 308249 for parts</i>	1
21	111706	CAPSCREW, 7/16-14 x 1-3/4"	2	89	187963	GASKET	1
23	111715	SCREW, 5/16-18 x 1-1/4"	6				
24	192166	HANDLE, sprayer	1				
25	112759	CAP, tubing	4				
26	239276	LEG, with gusset	1				
27■	104938	O-RING	1				
28	162453	NIPPLE, hex, 1/4 npsm x 1/4 npt, 1-3/16"	2				
29	235009	PRESSURE TRANSDUCER	1				
30	114026	CLIP, spring	1				
31	108850	SCREW, filh, 8-32 x 1-1/4"	1				
32	187624	SUCTION HOSE & TUBE	1				
33	187652	DRAIN HOSE	1				
34	111705	SCREW, filh, 8-32 x 2-1/2"	3				
35	290378	LABEL, identification	1				
36	111612	ADAPTER, tube, 9/16-18	1				
37	187895	LEG, sprayer	2				
38	192167	INLET TUBE	1				
39	235004	STRAINER	1				
42	235014	DRAIN VALVE KIT <i>Includes items 42a to 42e</i>	1				
42a	111699	. GASKET, valve seat	1				
42b	187615	. SEAT, drain valve	1				
42c	224968	. STEM, drain valve	1				
42d■	168110	. O-RING, stem	1				
42e	110110	. SEALANT, pipe (not shown)	1				
43	224807	BASE, valve	1				
44	111600	PIN, grooved, 3/32 x 1"	1				
45	187625	HANDLE, drain valve	1				

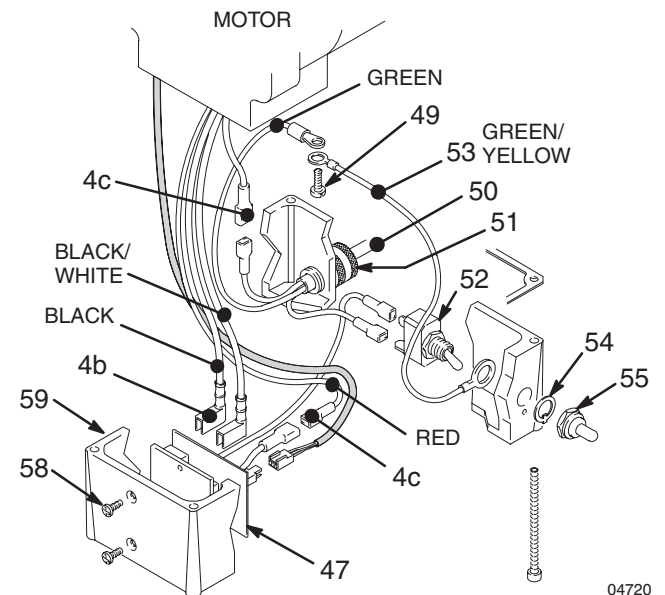

▲ Extra warning labels available free of charge.  
 † Motor Brush and Spring Replacement Kit, 236967 is available. Purchase separately.  
 ■ Replace Ref. No. 27 with 114048 and Ref. No. 42d with 112319 if using severe solvents such as lacquer thinner and acetone.

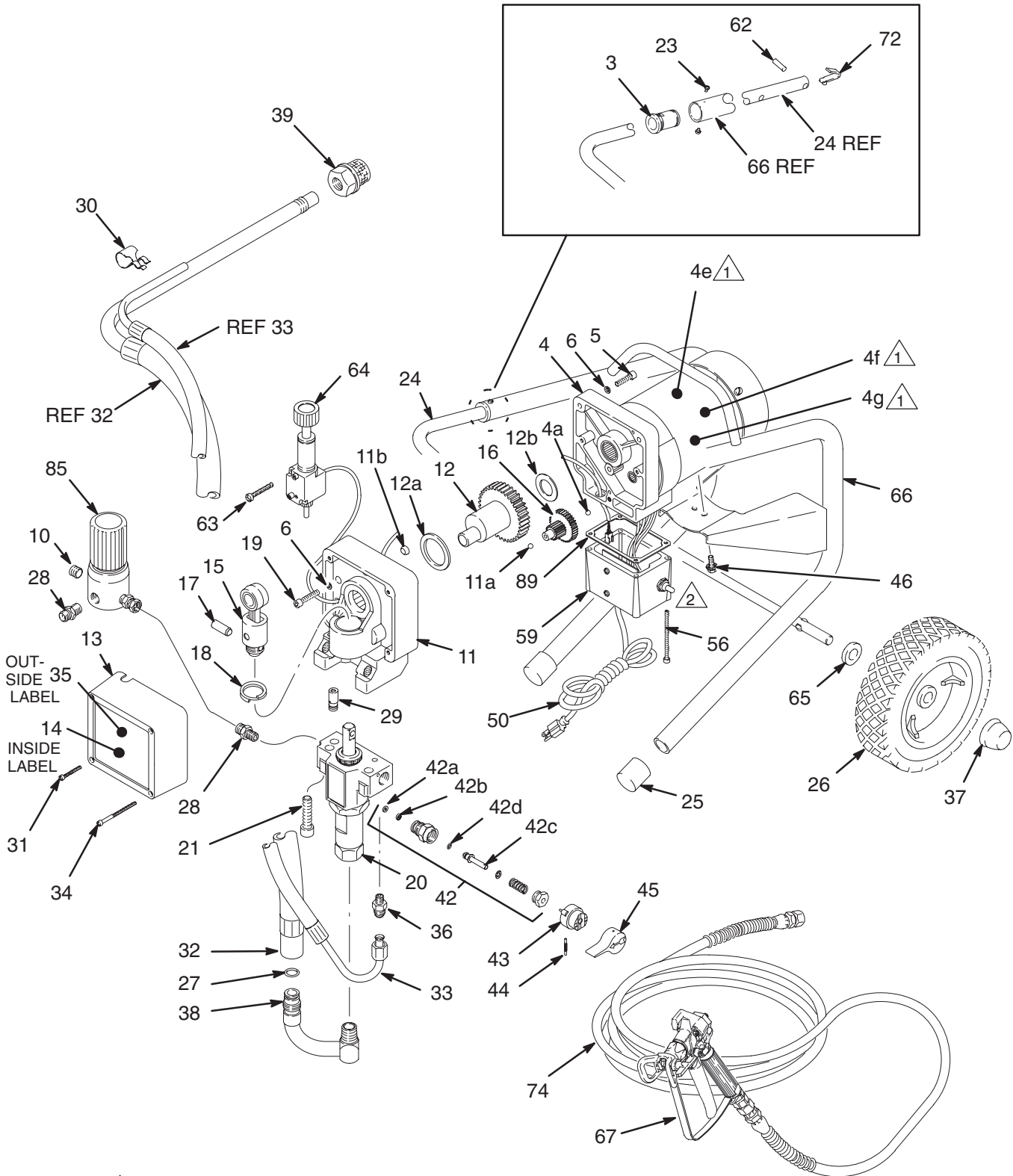

# Sprayer Parts Drawing

Model 231585, Series A



-  Label
-  See page 23 for detail

O5120

# Sprayer Parts List

## Model 231585, Series A

Ref. No.	Part No.	Description	Qty.	Ref. No.	Part No.	Description	Qty.
3	280290	SLEEVE, cart	2	45	187625	HANDLE, drain valve	1
4†	237458	MOTOR KIT <i>Includes items 4a to 4f</i>	1	46	110997	SCREW, washer/hex hd, 5/16"	2
4a	100069	. BALL, sst, 1/4" dia.	1	47	235707	MOTOR START BOARD <i>Includes items 47a to 47c</i>	1
4b	111616	. TERMINAL, flat, 1/4" (f), 18 awg	2	48▲	186620	LABEL, ground terminal	1
4c	107503	. TERMINAL, 3/16" (m), 16 awg	2	49	110037	SCREW, mach, pnhd, 10-24 x 5/8"	1
4d▲	187784	. LABEL, DANGER, French	1	50	235010	POWER CORD SET	1
4e▲	187791	. LABEL, DANGER, English	1	51	111617	STRAIN RELIEF BUSHING, 3/8-18 npt	1
4f▲	187975	. LABEL, WARNING, electric shock	1	52	105679	SWITCH, ON/OFF	1
5	100643	SCREW, socket head, 1/4-20 x 1"	3	53	235035	GROUND HARNESS	1
6	105510	LOCKWASHER, 1/4"	3	54	105658	LOCKING RING	1
10	100721	PLUG, 1/4-18 npt(f)	1	55	105659	BOOT, switch	1
11	224965	DRIVE HOUSING KIT <i>Includes item 11a, 11b</i>	1	56	111703	SCREW, filh, 10-24 x 3"	4
11a	100069	. BALL, stainless steel, 1/4" dia.	1	58	100035	SCREW, pan hd, 8-32 x 5/16"	2
11b	111726	. PLUG	1	59	187795	JUNCTION BOX	1
12	224803	CRANKSHAFT <i>Includes items 12a, 12b</i>	1	62	109567	PIN, handle	2
12a	180131	. BEARING, thrust	1	63	111704	SCREW, filh, 10-24 x 1-5/8"	2
12b	107434	. BEARING	1	64	239515	PRESSURE CONTROL KIT	1
13	187789	COVER, front	1	65	109570	WASHER, cart	2
14▲	177762	LABEL, WARNING	1	66	235735	FRAME, cart	1
15	218359	CONNECTING ROD	1	67	238350	CONTRACTOR FTx GUN <i>See manual 308-645 for parts</i>	1
16	218364	GEAR REDUCER	1	68	206994	TSL, 8 oz. (not shown)	1
17	176818	PIN, headless, 3/8" dia. x 1"	1	72	178565	BUTTON, spring	2
18	176817	SPRING, retaining	1	74	238361	HOSE, grounded, nylon; 1/4" ID; cpld 1/4 npsm(f); 50 ft (15 m); spring guards both ends	1
19	103345	SCREW, socket head, 1/4-20 x 1-1/4"	5	85	239447	FILTER, fluid <i>See Manual 308-249 for parts</i>	1
20	235699	PUMP KIT <i>See manual 308-190 for parts</i>	1	89	187963	GASKET	1
21	111706	CAPSCREW, 7/16-14 x 1-3/4"	2	▲ <i>Extra warning labels available free of charge.</i>			
23	112620	SCREW, 6-32 x 0.187"	4	† <i>Motor Brush and Spring Replacement Kit, 236967 is available. Purchase separately.</i>			
24	189934	HANDLE, sprayer	1	■ <i>Replace Ref. No. 27 with 114048 and Ref. No. 42d with 112319 if using severe solvents such as lacquer thinner and acetone.</i>			
25	112759	CAP, tubing	2				
26	110849	WHEEL, sprayer	2				
27■	104938	O-RING	1				
28	162453	NIPPLE, hex, 1/4 npsm x 1/4 npt, 1-3/16"	2				
29	235009	PRESSURE TRANSDUCER	1				
30	114026	CLIP, spring	1				
31	108850	SCREW, filh, 8-32 x 1-1/4"	1				
32	187624	SUCTION HOSE & TUBE	1				
33	187652	DRAIN HOSE	1				
34	111705	SCREW, filh, 8-32 x 2-1/2"	3				
35	290378	LABEL, identification	1				
36	111612	ADAPTER, tube, 9/16-18	1				
37	112612	HUBCAP, wheel	2				
38	192167	INLET TUBE	1				
39	235004	STRAINER	1				
42	235014	DRAIN VALVE KIT <i>Includes items 42a to 42e</i>	1				
42a	111699	. GASKET, valve seat	1				
42b	187615	. SEAT, drain valve	1				
42c	224968	. STEM, drain valve	1				
42d■	168110	. O-RING, stem	1				
42e	110110	. SEALANT, pipe (not shown)	1				
43	224807	BASE, valve	1				
44	111600	PIN, grooved, 3/32 x 1"	1				

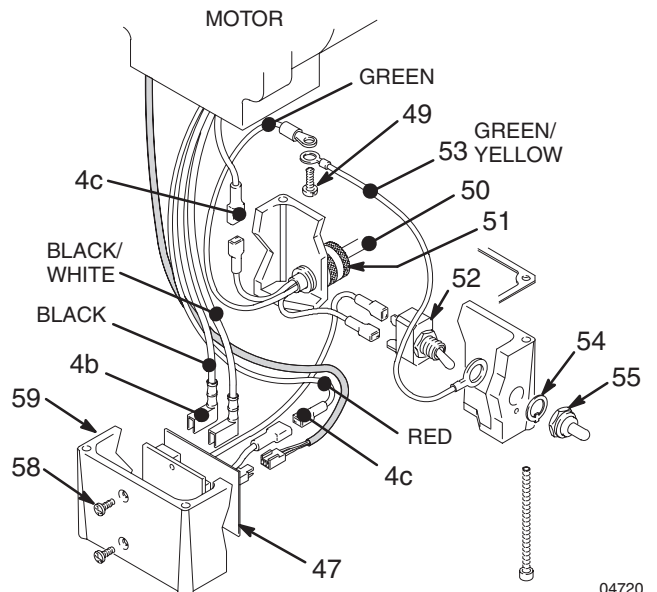

04720

# Sprayer Parts Drawing

Model 232676, Series A  
 Model 232677, Series A

- △ 1 Label
- △ 2 See page 25 for detail
- △ 3 Appear on opposite side

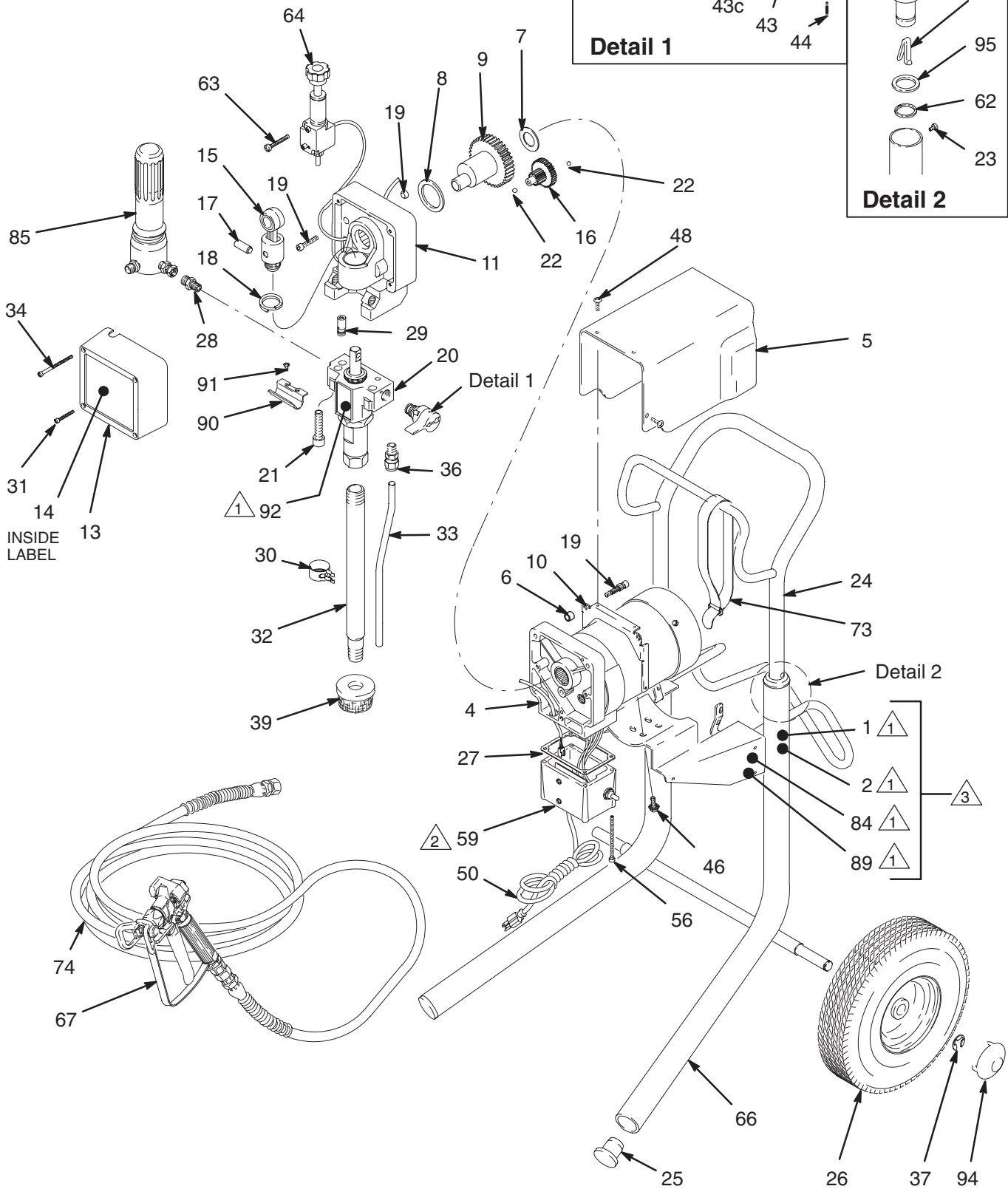



# Sprayer Parts List

## Model 232676, Series A, and Model 232677, Series A

Ref. No.	Part No.	Description	Qty.	Ref. No.	Part No.	Description	Qty.
1▲	194176	LABEL, danger, English	1	52	111930	SWITCH, ON/OFF	1
2▲	194177	LABEL, danger, French	2	53	235035	GROUND HARNESS	1
3	192027	SLEEVE, cart	2	54	105658	LOCKING RING	1
4†	237458	MOTOR KIT	1	55	105659	BOOT, switch	1
5	240996	SHIELD, motor includes 48	1	56	111703	SCREW, filh, 10–24 x 3"	4
6	194187	SPACER	2	58	100035	SCREW, pan hd, 8–32 x 5/16"	2
7	107434	BEARING	1	59	187795	JUNCTION BOX	1
8	180131	BEARING, thrust	1	61	111616	. TERMINAL, flat, 1/4" (f), 18 awg	2
9	224803	CRANKSHAFT <i>Includes items 8, 7</i>	1	60	107503	. TERMINAL, 3/16" (m), 16 awg	2
10	194500	BRACKET, shield	1	62	110243	RING, retaining	2
11	224965	DRIVE HOUSING KIT	1	63	114416	SCREW, filh, 10–24 x 1–5/8"	2
13	187789	COVER, front	1	64	241092	PRESSURE CONTROL KIT	1
14▲	188360	LABEL, WARNING	1	66	240007	FRAME, cart	1
15	218359	CONNECTING ROD	1	67	238350	CONTRACTOR FTx GUN Used with Model 232676 <i>See manual 308–645 for parts</i>	1
16	218364	GEAR REDUCER	1	68	206994	TSL, 8 oz. (not shown)	1
17	176818	PIN, headless, 3/8" dia. x 1"	1	72	111590	BUTTON, spring	2
18	176817	SPRING, retaining	1	73	114271	STRAP, retaining	1
19	114803	SCREW, socket head, with nylon patch, 1/4–20 x 1–1/4"	5	74	238361	HOSE, grounded, nylon; 1/4" ID; cpld 1/4 npsm(f); 50 ft (15 m); spring guards both ends	1
20	235699	PUMP KIT <i>See manual 308–190 for parts</i>	1	84▲	187975	LABEL, WARNING, electric shock	1
21	111706	CAPSCREW, 7/16–14 x 1–3/4"	2	85	240038	FILTER, fluid <i>See Manual 308–249 for parts</i>	1
22	100069	BALL, sst, 1/4"	2	89▲	192838	LABEL, warning	1
23	109032	SCREW, 10–32 x 0.25"	4	90	190321	HANGER, pail	1
24	239998	HANDLE, sprayer	1	91	112777	SCREW, mach, oval hd	2
25	108691	PLUG, tubing	2	92▲	192840	LABEL, warning	1
26	106062	WHEEL, sprayer	2	94	104811	HUBCAP	4
27	187963	GASKET	1	95	183350	WASHER	1
28	193718	NIPPLE, hex, 1/4 npsm x 1/4 npt, 1–3/16"	1				
29	235009	PRESSURETRANSDUCER	1				
30	192648	CLIP, spring	1				
31	114415	SCREW, filh, 8–32 x 1–1/4"	1				
32	192169	SUCTION TUBE	1				
33	061132	DRAIN TUBE	1				
34	111705	SCREW, filh, 8–32 x 2–1/2"	3				
36	205437	CONNECTOR, tube	1				
37	101242	RING, retaining, wheel	2				
39	183770	STRAINER	1				
42	235014	DRAIN VALVE KIT <i>Includes items 42a to 42e</i>	1				
42a	111699	. GASKET, valve seat	1				
42b	187615	. SEAT, drain valve	1				
42c	224968	. STEM, drain valve	1				
42d■	168110	. O-RING, stem	1				
42e	110110	. SEALANT, pipe (not shown)	1				
43	224807	BASE, valve	1				
44	111600	PIN, grooved, 3/32 x 1"	1				
45	187625	HANDLE, drain valve	1				
46	110997	SCREW, washer/hex hd, 5/16"	2				
47	235707	MOTOR START BOARD <i>includes items 47a to 47c</i>	1				
48	108865	SCREW, mach, pnhd,	2				
49	110037	SCREW, mach, pnhd, 10–24 x 5/8"	1				
50	238056	POWER CORD SET	1				
51	111617	STRAIN RELIEF BUSHING, 3/8–18 npt	1				

▲ Extra warning labels available free of charge.

† Motor Brush and Spring Replacement Kit, 236967 is available. Purchase separately.

■ Replace Ref. No. 42d with 112319 if using severe solvents such as lacquer thinner and acetone.

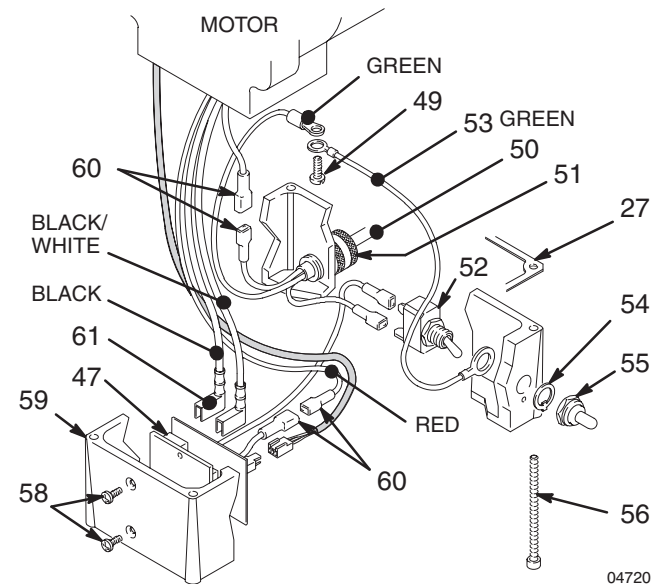



# Technical Data

## Power Requirements

Models 231584, 231818, 231585 . . . . .120 VAC, 60 Hz,  
1 phase, 15A minimum or 4000W generator

Models 232676, 232677 . . . . .120 VAC, 60 Hz,  
1 phase, 15A minimum or 4000W generator

Working Pressure Range 0–3000 psi (0–210 bar, 0–21 MPa)

Motor . . . . .3/4.hp

Cycles/Gallon (liter) . . . . .620 (164)

Delivery . . . . .0.50 gpm (1.9 lpm)

Tip Size . . . . .one gun to 0.023 new tip  
*with latex at 2000 psi (138 bar, 13.8 MPa)*

Power Cord . . . . .14 AWG (1.5 mm<sup>2</sup>), 3 wire, 6 ft (1.8 m)

Inlet Paint Strainer . . . . .12 mesh (1525 micron)

Stainless Steel Screen, reusable

Pump Inlet Size . . . . .1/2 npt(f)

Fluid Outlet Size . . . . .1/4 npsm

## Wetted Parts:

*Displacement Pump* . . . . .Stainless steel, Carbon steel,  
PTFE<sup>®</sup>, Aluminum, Polyethylene, Delrin<sup>®</sup>, Leather

**NOTE:**PTFE and Delrin are trademarks of the DuPont Company

## DANGER LABELS

An English language DANGER label is on your sprayer. If you have painters who do not read English, order one of the following labels to apply to your sprayer. The drawing shows the best placement of these labels for good visibility.

Order the labels from your Graco distributor.

- French**      **194177**
- Spanish**    **185961**
- German**     **186041**
- Greek**      **186045**
- Korean**     **186049**
- English**    **194176**

Apply other language here

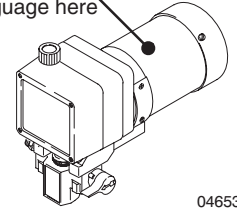

04653

# Dimensions

	Model 231584, 231818	Model 231585	Model 232676, 232677
Weight (dry w/o packaging)	37 lb (17 kg)	50 lb (22.7 kg)	47 lb (21.4 kg)
Height	19 in. (483 mm)	21 in. (533 mm)	29.5 in. (749 mm) Handle down 39.5 in. (1003 mm) Handle up
Length	15 in. (381 mm)	22 in. (559 mm)	21 in. (533 mm)
Width	14 in. (356 mm)	15 in. (381 mm)	20.5 in. (521 mm)

# Graco Warranty

Graco warrants all equipment listed in this manual which is manufactured by Graco and bearing its name to be free from defects in material and workmanship on the date of sale by an authorized Graco distributor to the original purchaser for use. With the exception of any special extended or limited warranty published by Graco, Graco will, for a period of twelve months from the date of sale, repair or replace any part of the equipment determined by Graco to be defective. This warranty applies only when the equipment is installed, operated and maintained in accordance with Graco's written recommendations.

This warranty does not cover, and Graco shall not be liable for general wear and tear or any malfunction, damage or wear caused by faulty installation, misapplication, abrasion, corrosion, inadequate or improper maintenance, negligence, accident, tampering, or substitution of non-Graco component parts. Nor shall Graco be liable for malfunction, damage or wear caused by the incompatibility of Graco equipment with structures, accessories, equipment or materials not supplied by Graco, or the improper design, manufacture, installation, operation or maintenance of structures, accessories, equipment or materials not supplied by Graco.

This warranty is conditioned upon the prepaid return of the equipment claimed to be defective to an authorized Graco distributor for verification of the claimed defect. If the claimed defect is verified, Graco will repair or replace free of charge any defective parts. The equipment will be returned to the original purchaser transportation prepaid. If inspection of the equipment does not disclose a defect in material or workmanship, repairs will be made at a reasonable charge, which charges may include the costs of parts, labor and transportation.

Graco's sole obligation and buyer's sole remedy for any breach of warranty shall be as set forth above. The buyer agrees that no other remedy (including, but not limited to, incidental or consequential damages for lost profits, lost sales, injury to person or property, or any other incidental or consequential loss) shall be available. Any action for breach of warranty must be brought within two (2) years of the date of sale.

**GRACO MAKES NO WARRANTY, AND DISCLAIMS ALL IMPLIED WARRANTIES OF MERCHANTABILITY AND FITNESS FOR A PARTICULAR PURPOSE IN CONNECTION WITH ACCESSORIES, EQUIPMENT MATERIALS OR COMPONENTS SOLD BUT NOT MANUFACTURED BY GRACO.** These items sold, but not manufactured by Graco (such as electric motors, gas engines, switches, hose, etc.), are subject to the warranty of their manufacturer. Graco will provide purchaser with reasonable assistance in making any claim for breach of these warranties.

In no event will Graco be liable for indirect, incidental, special or consequential damages resulting from Graco supplying equipment hereunder, or the furnishing, performance, or use of any products or other goods sold hereto, whether due to a breach of contract, breach of warranty, the negligence of Graco, or otherwise.

## **FOR GRACO CANADA CUSTOMERS**

The parties acknowledge that they have required that the present document, as well as all documents, notices and legal proceedings entered into, given or instituted pursuant hereto or relating directly or indirectly hereto, be drawn up in English. Les parties reconnaissent avoir convenu que la rédaction du présente document sera en Anglais, ainsi que tous documents, avis et procédures judiciaires exécutés, donnés ou intentés à la suite de ou en rapport, directement ou indirectement, avec les procédures concernées.

## **ADDITIONAL WARRANTY COVERAGE**

Graco does provide extended warranty and wear warranty for products described in the "Graco Contractor Equipment Warranty Program".

# Phone Number

**TO PLACE AN ORDER**, contact your Graco distributor, or call this number to identify the distributor closest to you: **1-800-690-2894 Toll Free**

*All written and visual data contained in this document reflects the latest product information available at the time of publication. Graco reserves the right to make changes at any time without notice.*

**Sales Offices:** Minneapolis, Detroit

**Foreign Offices:** Belgium, England, Korea, France, Germany, Hong Kong, Japan

**GRACO INC. P.O. BOX 1441 MINNEAPOLIS, MN 55440-1441**

**<http://www.graco.com>**

PRINTED IN U.S.A. 308922 November 1998, Revised January 1999