

312015D

EN

Displacement Pump

Model 255198, Series A

190ES/ 210ES, 190LTS/210LTS

Pro 230ES, Pro 270ES

Pro 270GS

Maximum Working Pressure 3300 psi (223 bar, 23 MPa)



Important Safety Instructions

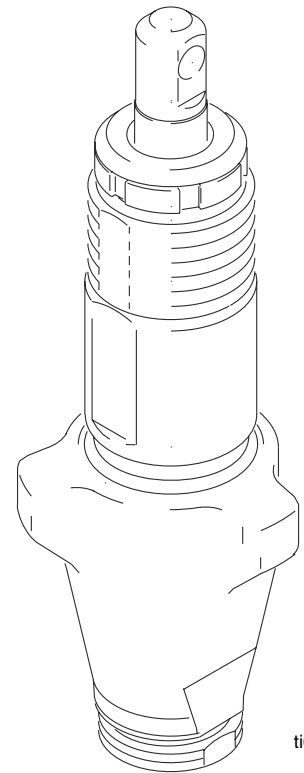

Read all warnings and instructions in this manual.
Save these instructions.



ti6144a

Warnings

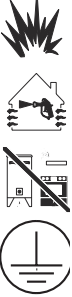
The following warnings are for the setup, use, grounding, maintenance, and repair of this equipment. The exclamation point symbol alerts you to a general warning and the hazard symbols refer to procedure-specific risks. When these symbols appear in the body of this manual or on warning labels, refer back to these Warnings. Product-specific hazard symbols and warnings not covered in this section may appear throughout the body of this manual where applicable.

 WARNING	
	<p>FIRE AND EXPLOSION HAZARD</p> <p>Flammable fumes, such as solvent and paint fumes, in work area can ignite or explode. To help prevent fire and explosion:</p> <ul style="list-style-type: none"> • Use equipment only in well ventilated area. • Eliminate all ignition sources; such as pilot lights, cigarettes, portable electric lamps, and plastic drop cloths (potential static arc). • Keep work area free of debris, including solvent, rags and gasoline. • Do not plug or unplug power cords, or turn power or light switches on or off when flammable fumes are present. • Ground all equipment in the work area. See Grounding instructions. • Use only grounded hoses. • Hold gun firmly to side of grounded pail when triggering into pail. Do not use pail liners unless they are antistatic or conductive. • Stop operation immediately if static sparking occurs or you feel a shock. Do not use equipment until you identify and correct the problem. • Keep a working fire extinguisher in the work area.
	<p>SKIN INJECTION HAZARD</p> <p>High-pressure spray is able to inject toxins into the body and cause serious bodily injury. In the event that injection occurs, get immediate surgical treatment.</p> <ul style="list-style-type: none"> • Do not aim the gun at, or spray any person or animal. • Keep hands and other body parts away from the discharge. For example, do not try to stop leaks with any part of the body. • Always use the nozzle tip guard. Do not spray without nozzle tip guard in place. • Use Graco nozzle tips. • Use caution when cleaning and changing nozzle tips. In the case where the nozzle tip clogs while spraying, follow the Pressure Relief Procedure for turning off the unit and relieving the pressure before removing the nozzle tip to clean. • Do not leave the unit energized or under pressure while unattended. When the unit is not in use, turn off the unit and follow the Pressure Relief Procedure for turning off the unit. • Check hoses and parts for signs of damage. Replace any damaged hoses or parts. • This system is capable of producing 3300 psi. Use Graco replacement parts or accessories that are rated a minimum of 3300 psi. • Always engage the trigger lock when not spraying. Verify the trigger lock is functioning properly. • Verify that all connections are secure before operating the unit. • Know how to stop the unit and bleed pressure quickly. Be thoroughly familiar with the controls.

Trigger Lock

Always engage the trigger lock when you stop spraying to prevent the gun from being triggered accidentally by hand or if dropped or bumped.

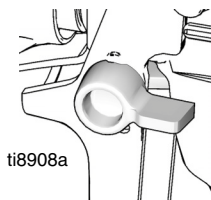

Trigger Locked

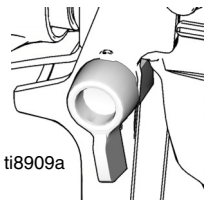

Trigger Unlocked

Pressure Relief Procedure

<p>The system pressure must be manually relieved to prevent the system from starting or spraying accidentally. To reduce the risk of an injury from accidental spray from the gun, splashing fluid, or moving parts, follow the Pressure Relief Procedure whenever you:</p> <ul style="list-style-type: none"> • are instructed to relieve the pressure, • stop spraying, • check or service any of the system equipment, • or install or clean the spray nozzle. 						

1. Engage gun trigger lock.

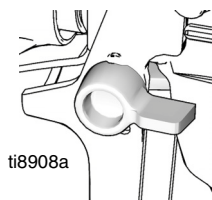

ti8908a

2. Turn switch to OFF.

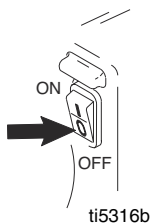

ti5316b

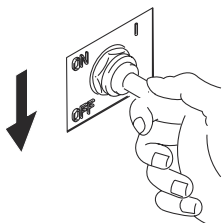

ti2707a

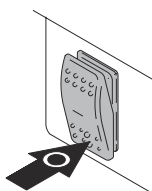

ti5957a

3. Unplug power cord or shut engine off.

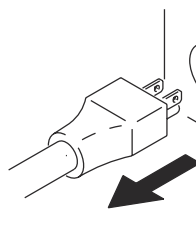

ti2718a

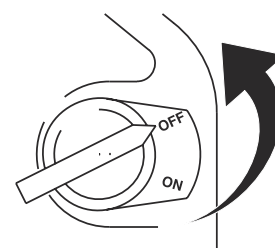

ti5261a

4. Disengage gun trigger lock.

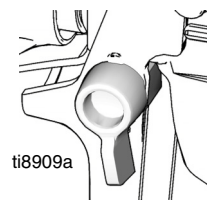

ti8909a

5. Hold metal part of gun against grounded metal pail and trigger gun into pail to relieve pressure.



WASTE

ti2599a

6. Engage gun trigger lock.

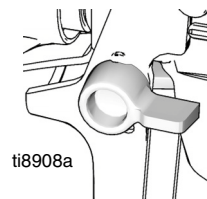

ti8908a

7. Open any fluid drain valves in system. Leave drain valve open until ready to dispense again.

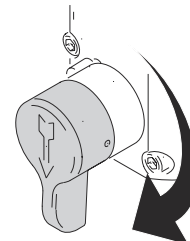

ti19397a

Disassembling the Pump

1. Remove packing nut and throat adjustment spacer.



ti2776

2. Unscrew intake valve from cylinder.

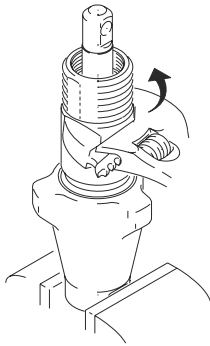

ti0779a

3. Disassemble intake valve. Clean and inspect. O-ring may require a pick for removal.

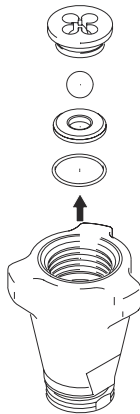

ti6145a

4. Tap piston rod out of cylinder with a hammer or flip over and tap piston rod out against a bench.

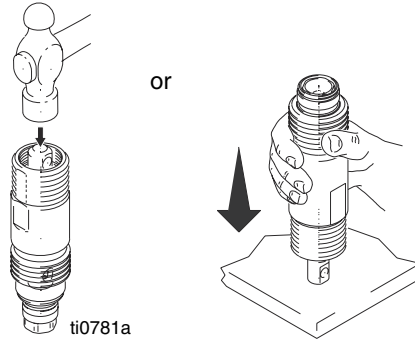

ti0781a

<p>Do not clean or wipe the piston valve threads. Cleaning the piston valve threads could destroy the special sealing patch and cause the piston valve to come loose during operation, causing a pump burst and possible serious bodily injury.</p>						

5. Unscrew piston valve from piston rod.

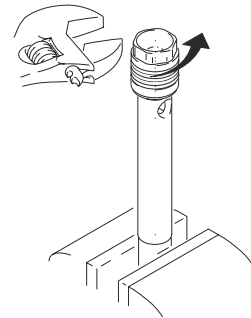

ti0782a

- Clean and inspect parts. (The piston has a special thread locking/sealing patch. Do not remove the patch. The patch allows for disassembly/assembly procedures before it is necessary to apply thread sealant to the threads. On fifth assembly apply thread sealant to threads.)

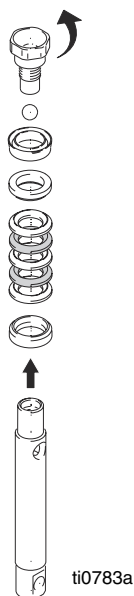

- Remove and discard throat packings and glands from cylinder.

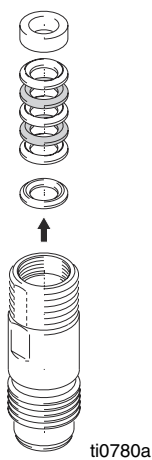

Assemble

- Soak leather packings in SAE 30W oil for 1 hour before assembly.

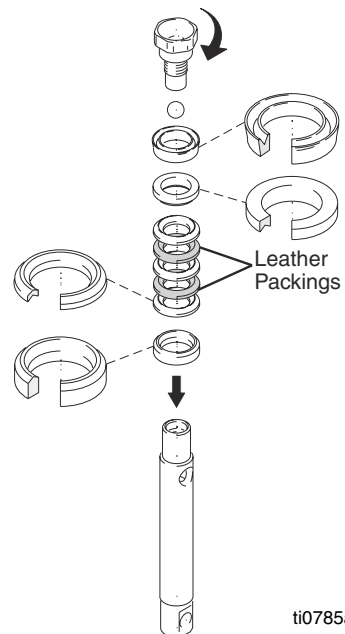

- Install ball in piston rod. If thread sealant is applied to piston valve threads, ensure that none gets on the ball.

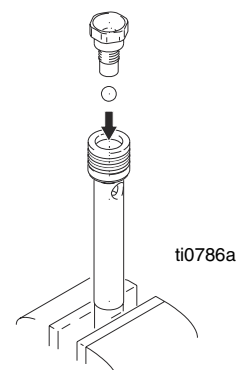

- Torque to 27 ± 3 ft-lb (37 ± 4 N•m).

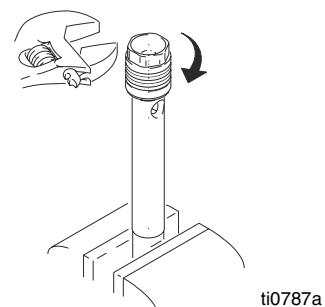

Warnings

4. Soak leather packings in SAE 30W oil for 1 hour before assembly.

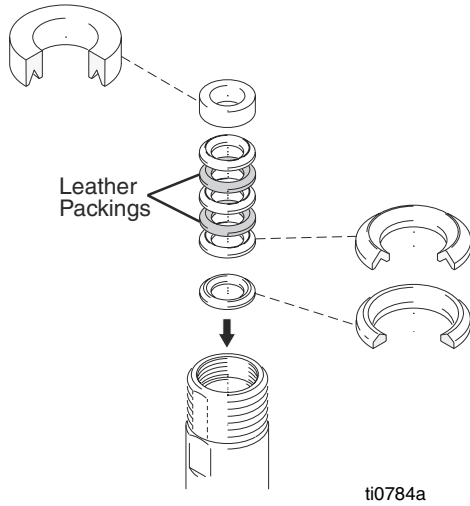

7. Grease top two inches of piston rod.

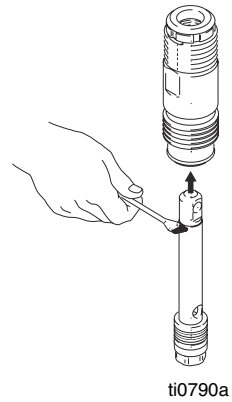

5. Loosely install packing nut onto cylinder.

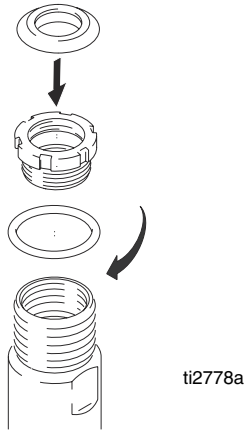

8. Grease and place on O.D. ring groove.

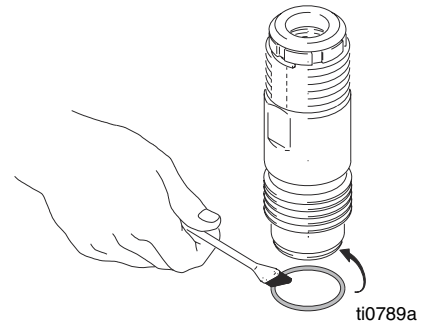

6. Apply liberal amounts of grease or oil.

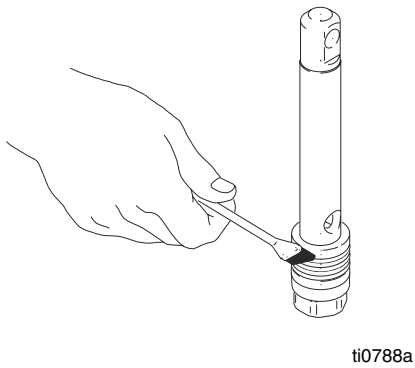

9. Clean seat thoroughly. Reassemble intake valve with a seat, ball, and new o-ring. Seat may be flipped over and used on other side.

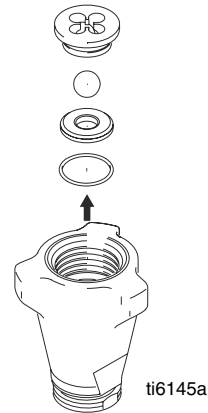

10. Torque to 60 ± 5 ft-lb (81 ± 7 N•m).

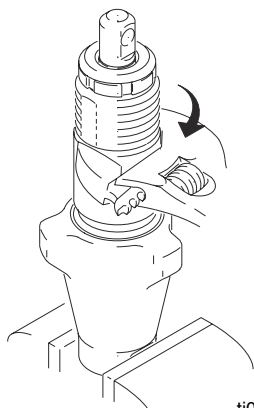

ti0792a

11. Torque to 75 ± 5 ft-lb (8.5 ± 5 N•m) or additional 1/2 turn from hand tight.

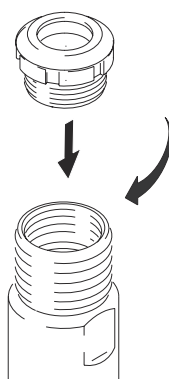

ti2778b

12. Storage



ti19398a

Throat Packing Adjustment

When pump packings begin to leak after much use, tighten packing nut down until leakage stops or lessens. This allows approximately 100 gallons of additional operation before a repacking is required. Packing nut can be tightened without o-ring removal.

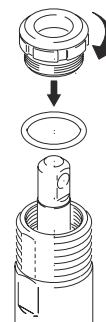

ti2779a

Parts

Ref No.	Part No.	Description	Qty
201	249125	ROD, displacement, includes 212	1
202*	180656	BUTTON, plug	1
203	193047	NUT, packing	1
204*	176757	GLAND, female, throat	1
205*	176754	GLAND, male throat	1
206	243176	CYLINDER, pump	1
207*	105444	BALL, sst, 0.3125 in.	1
208*	195129	GLAND, male piston	1
209*	180073	GLAND, female, piston	1
211*	15G234	GUIDE, piston	1
212	239937	VALVE, piston (included with 201)	1
213†	15C011	GUIDE, ball	1
215†	246429	KIT, seat, carbide includes 213, 217 and 218	1
216	15B611	VALVE, intake housing	1
217*†	15B112	PACKING, o-ring (0.941 in. OD)	1
218*†	105445	BALL, sst, 0.5000 in.	1
219*	108526	O-RING, PTFE	1
220*	117459	O-RING	1
221*	176755	V-PACKING, leather, throat	2
222*	192710	V-PACKING, throat, V-Max™ UHMWPE, blue	3
223*	176749	V-PACKING, leather, piston	2
224*	192712	V-PACKING, piston, V-Max™ UHMWPE, blue	3
225	162453	NIPPLE, 1/4 npsm x 1/4 npt	1
228	158776	SPACER, throat, nut	1

*Also included in Kit 255204

†Also included in Kit 246429

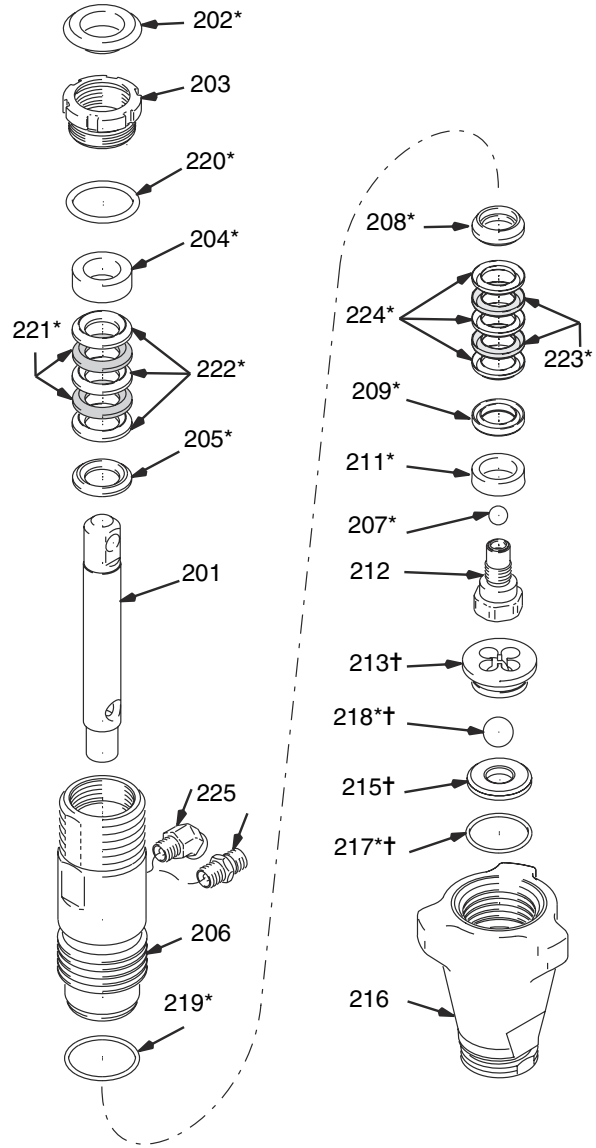

ti2780c

ti7338a

Technical Data

Displacement Pump		
	US	Metric
Maximum fluid working pressure	3300 psi	23 MPa, 228 bar
Inlet/Outlet Sizes		
Fluid inlet size	1.0 in. diameter	
Fluid outlet size 248204, 255968, 277069	1/4 npt(f)	
Materials of Construction**		
Wetted materials on all models	stainless steel, PTFE, leather, nylon, zinc-plated carbon steel, tungsten carbide, chrome plating, UHMWPE, acetal, polyethylene, nylon	

Graco Standard Warranty

Graco warrants all equipment referenced in this document which is manufactured by Graco and bearing its name to be free from defects in material and workmanship on the date of sale to the original purchaser for use. With the exception of any special, extended, or limited warranty published by Graco, Graco will, for a period of twelve months from the date of sale, repair or replace any part of the equipment determined by Graco to be defective. This warranty applies only when the equipment is installed, operated and maintained in accordance with Graco's written recommendations.

This warranty does not cover, and Graco shall not be liable for general wear and tear, or any malfunction, damage or wear caused by faulty installation, misapplication, abrasion, corrosion, inadequate or improper maintenance, negligence, accident, tampering, or substitution of non-Graco component parts. Nor shall Graco be liable for malfunction, damage or wear caused by the incompatibility of Graco equipment with structures, accessories, equipment or materials not supplied by Graco, or the improper design, manufacture, installation, operation or maintenance of structures, accessories, equipment or materials not supplied by Graco.

This warranty is conditioned upon the prepaid return of the equipment claimed to be defective to an authorized Graco distributor for verification of the claimed defect. If the claimed defect is verified, Graco will repair or replace free of charge any defective parts. The equipment will be returned to the original purchaser transportation prepaid. If inspection of the equipment does not disclose any defect in material or workmanship, repairs will be made at a reasonable charge, which charges may include the costs of parts, labor, and transportation.

THIS WARRANTY IS EXCLUSIVE, AND IS IN LIEU OF ANY OTHER WARRANTIES, EXPRESS OR IMPLIED, INCLUDING BUT NOT LIMITED TO WARRANTY OF MERCHANTABILITY OR WARRANTY OF FITNESS FOR A PARTICULAR PURPOSE.

Graco's sole obligation and buyer's sole remedy for any breach of warranty shall be as set forth above. The buyer agrees that no other remedy (including, but not limited to, incidental or consequential damages for lost profits, lost sales, injury to person or property, or any other incidental or consequential loss) shall be available. Any action for breach of warranty must be brought within two (2) years of the date of sale.

GRACO MAKES NO WARRANTY, AND DISCLAIMS ALL IMPLIED WARRANTIES OF MERCHANTABILITY AND FITNESS FOR A PARTICULAR PURPOSE, IN CONNECTION WITH ACCESSORIES, EQUIPMENT, MATERIALS OR COMPONENTS SOLD BUT NOT MANUFACTURED BY GRACO. These items sold, but not manufactured by Graco (such as electric motors, switches, hose, etc.), are subject to the warranty, if any, of their manufacturer. Graco will provide purchaser with reasonable assistance in making any claim for breach of these warranties.

In no event will Graco be liable for indirect, incidental, special or consequential damages resulting from Graco supplying equipment hereunder, or the furnishing, performance, or use of any products or other goods sold hereto, whether due to a breach of contract, breach of warranty, the negligence of Graco, or otherwise.

FOR GRACO CANADA CUSTOMERS

The Parties acknowledge that they have required that the present document, as well as all documents, notices and legal proceedings entered into, given or instituted pursuant hereto or relating directly or indirectly hereto, be drawn up in English. Les parties reconnaissent avoir convenu que la rédaction du présente document sera en Anglais, ainsi que tous documents, avis et procédures judiciaires exécutés, donnés ou intentés, à la suite de ou en rapport, directement ou indirectement, avec les procédures concernées.

Graco Information

For the latest information about Graco products, visit www.graco.com.

TO PLACE AN ORDER, contact your Graco distributor or call 1-800-690-2894 to identify the nearest distributor.

*All written and visual data contained in this document reflects the latest product information available at the time of publication.
Graco reserves the right to make changes at any time without notice.*

For patent information, see www.graco.com/patents.

Original instructions. This manual contains English. MM 312015

Graco Headquarters: Minneapolis
International Offices: Belgium, China, Japan, Korea

GRACO INC. AND SUBSIDIARIES • P.O. BOX 1441 • MINNEAPOLIS MN 55440-1441 • USA

Copyright 2007, Graco Inc. All Graco manufacturing locations are registered to ISO 9001.

www.graco.com
Revised June 2012