

Product Features & Instructions

This is our standard model that incorporates the fundamental features of airweave technology. The firmness of the airfiber® material is consistently uniform, making it an ideal choice for individuals who prefer a firm and comfortable sleeping experience.

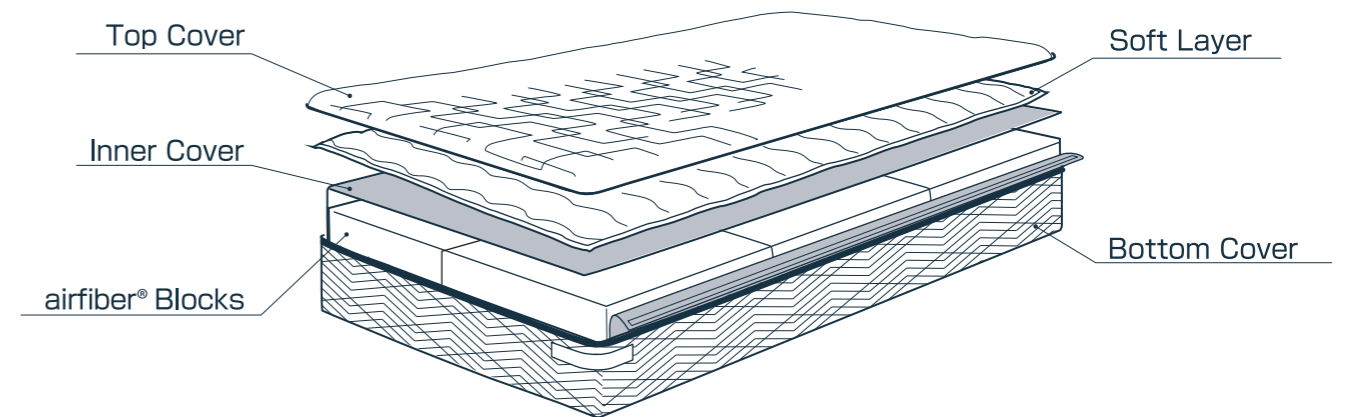

Contents

Make sure the following items are ready before assembly.

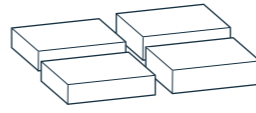
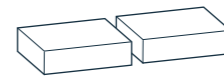
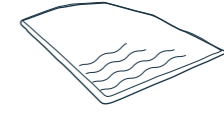
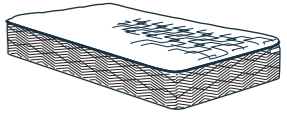
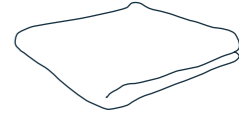
BOX 1	BOX 2	BOX 3
 <p>airfiber® Blocks (4)</p>	 <p>airfiber® Blocks (2)</p>  <p>Soft Layer (1)</p>	 <p>Cover (1)</p>  <p>Inner Cover (1)</p>

In Twin XL orders, Box 1 will include 2 airfiber Blocks, while Box 2 will contain 1 airfiber Block.

Assembly

1

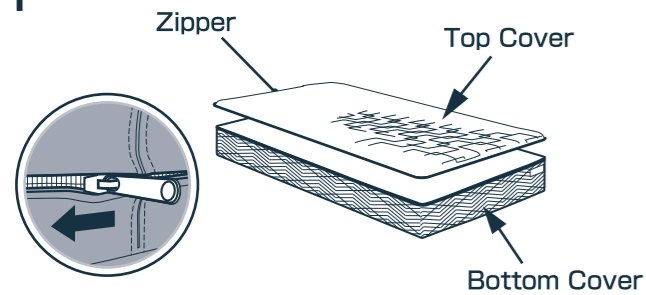

Completely unzip the outer cover to separate it into two parts.

2

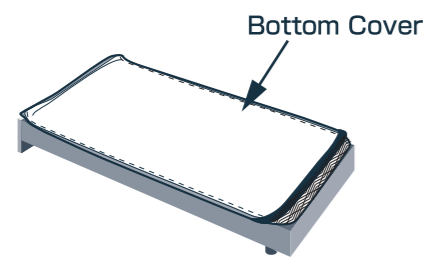

Place the bottom cover on your bed frame, ensuring it is smooth and wrinkle-free before proceeding with the setup.

3

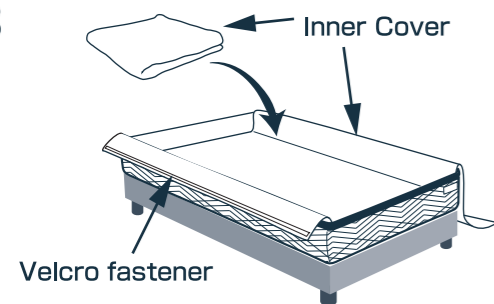

Open the Velcro and spread the inner cover evenly on top of the bottom cover.

4

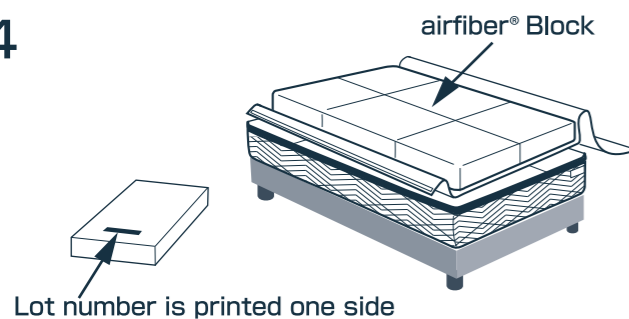

Unfasten the velcro-lined inner cover and evenly spread it on top of the outer cover, ensuring that the velcro fastener is positioned on the outer side of the outer cover. Position the airfiber® blocks with the printed lot number side facing downwards onto the bottom cover.

5

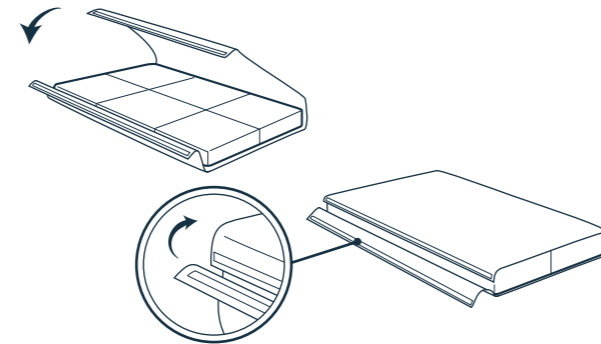

Tightly secure the airfiber® blocks with the Velcro fastener of the inner cover.

6

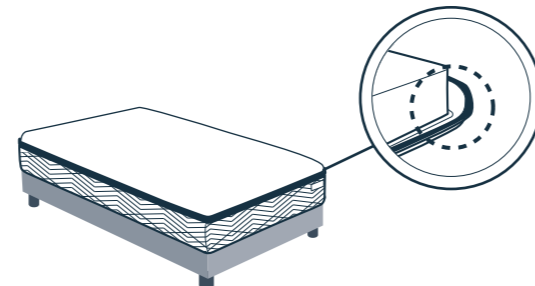

Make sure the airfiber® blocks are tightly fitted into each corner of the cover.

7

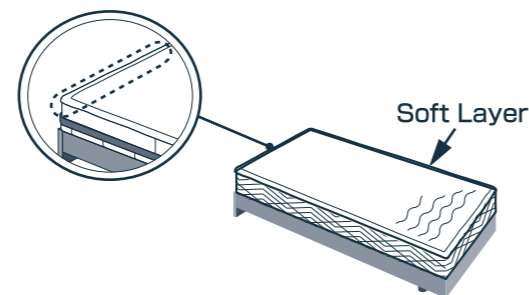

Place the optional soft layer on top of the airfiber® blocks, which are wrapped around the inner cover. This step allows you to add additional softness, if desired.

8

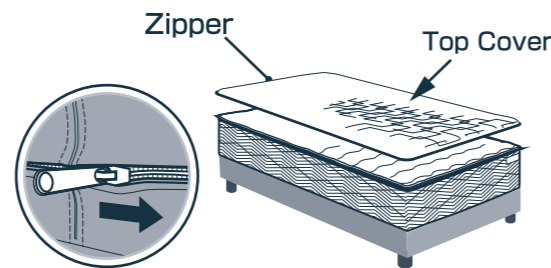

Place the top cover on the assembled layers and zip up the entire product. Ensure you zip carefully, applying minimal pressure to the mattress to prevent any potential damage to the airfiber® material.

Precautions

Initial Use

During the initial period of use, it is common to experience some muscle discomfort as your spine adjusts to proper alignment and your body familiarizes itself with new bedding. Typically, this discomfort improves within 2 to 4 weeks as you adapt. To enhance your comfort during this adjustment period, we recommend placing towels and blankets on the mattress.

For Long and Comfortable use

This product should be placed on the bed frame. It is recommended to use it with bed sheets or mattress pad. This will prevent damages and stains, and ensure a long life of use.

CAUTIONS

- Exercise caution when opening and closing the zipper to avoid pinching the fabric or tag inside.
- In the event of pilling or snagging on the cover, do not pull. Instead, use scissors to carefully cut any affected areas.
- Do not use airfiber® just by itself.
- Smoking on the mattress is strictly prohibited due to the risk of fire.
- If you experience any discomfort or notice any issues with your body while using this product, please discontinue use.
- Keep the mattress away from fire or heat-generating equipment.
- Avoid standing or jumping on the mattress to maintain its integrity and longevity.

How to Wash

To clean the mattress, unzip the cover and separate it into two parts. Wash each side of the cover separately to ensure thorough cleaning. The airfiber® inner material can be washed with water.

Covers & Softlayer

- Laundry
- The cover and soft layers can be dry cleaned or washed in a household washing machine. For the cover, use a maximum temperature of 30° C/86° F, and for the soft layers, use a maximum temperature of 40° C/105° F.
 - Follow the care label instructions located inside the cover when washing.
 - We recommend using the "blanket course" or a similar washing cycle.
 - Do not use bleach or fabric softener.

CAUTIONS

- Before washing, please consult the instruction manual of your washing machine to ensure it can accommodate the size of the mattress covers or soft layers, or any similarly sized items.
- Wash the cover separately without mixing it with other laundry.
- Fold the cover and wash it using the washing method for large items in the washing machine.
- Inner cover cannot be washed.

- How to Dry
- Dry the mattress covers or soft layers in the shade in a well-ventilated area.
 - Do not iron them.
 - Avoid using a tumble dryer.
 - Refrain from prolonged spin-drying to prevent issues such as wrinkles, disordered fur, color problems, or blowout of stuffing.
 - Dry them immediately after spin-drying to prevent wrinkles, odors, and other potential problems.

airfiber®

- Wash by hand using lukewarm water, with a maximum temperature of 40°C/105°F.
- Use a gentle soap, such as dish soap, to clean the airfiber®.
- If desired, sterilize the airfiber® by using a diluted alcohol solution mixed with water.
- Do not use a washing machine.
- Do not use a dryer for drying the airfiber® as it may cause damage. Do not attempt to dry clean the airfiber®.
- Dry in the shade in a well-ventilated area.